

IC697MDL750
New In Stock!
GE Fanuc

<http://www.pdfsupply.com/automation/ge-fanuc/series-90-70/IC697MDL750>

Series 90-70
1-919-535-3180

In Stock! 24/48 Volts dc Output, 0.5 Amp, Pos Logic (32) IC697M
IC697MD IC697MDL

www.pdfsupply.com

Email: sales@pdfsupply.com

GFK-0085G
August 1997

24/48 Volt DC, 0.5 Amp, 32-Point Output Module

Operation of the 24/48 Volt DC 0.5 Amp Output Module

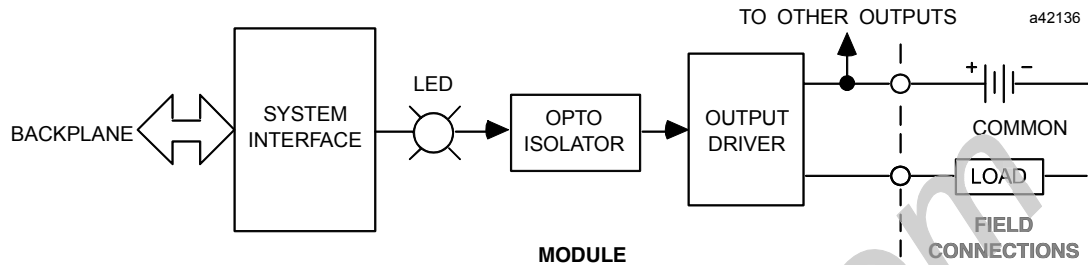

Figure 1. Block Diagram for IC697MDL750

Output Characteristics

The 24/48 Volt DC 0.5 Amp Output Module is compatible with a wide variety of load devices, such as:

- Solenoids
- Motor starters
- Indicators

The rating of 0.5 amp per point applies to the long-term current capacity of each point. Because of overall heat dissipation within the module, the maximum current for each group of 8 outputs is limited to 2 amperes.

Each output on this module is capable of transiently conducting a surge current which is much greater than its long-term current rating. The rate at which such surges can be repeated depends on the current rating of the device and the duty cycle (percent of time the device is ON).

For typical incandescent devices operating at a 50% duty cycle, the following repetition rates apply.

Steady-State Current (mA)	Repetition Rate (Hz)
100	5
250	1
500	0.1

Fault Mode Selection

The module can be configured from the programmer so that output points assume one of two states in response to certain operating or default conditions.

- Maintain existing output state
- Turn outputs OFF

This is explained in more detail in the *Programmable Controllers Reference Manual*.

Fusing

The 24/48 VDC 0.5 Amp Output Module has no fuses. If protection is required, a fuse as specified below may be externally connected to each output point by the user.

- Littlefuse 312.750 (3/4 amp, 250 volt) Fast Acting
- Bussmann AGC-3/4 (3/4 amp, 250 volt) Fast Acting

Module Mechanical Keying

This module includes a mechanical key that prevents inadvertent substitution of one module type for another in a given slot. The key fits a uniquely shaped area on the board below the connector. The key is included with each module.

When the module is first installed, the key latches onto the backplane center rail. When the module is extracted, the key remains in the center rail, configuring the slot to accept only identical module types.

If it is necessary to change the module location in the rack after the key has been latched onto the center rail of the rack, the key can be removed by pushing it upward to unhook the latch while pulling it off the rail. It may then be reinserted onto the module and the module inserted into the rack in the desired location. Note: Only the power supply can be placed in the leftmost rack position.

Field Wiring

The module is wired as shown in Figure 2. Since each group of eight outputs is isolated from the others, a wire from the power source to the power input terminals for each group is required (power input terminals for each group are not connected inside the module).

The detachable field wiring terminal board will accept wire sizes from #22 (0.36 mm²) through #14 (2.10 mm²). Two wires may be terminated on a given lug if both wires are the same size. There is room for a bundle of forty #14 (2.10 mm²) wires to be routed out through the terminal board cavity.

The wire bundle can be secured to the terminal board by passing a cable tie through a cleat located at the lower corner of the terminal board.

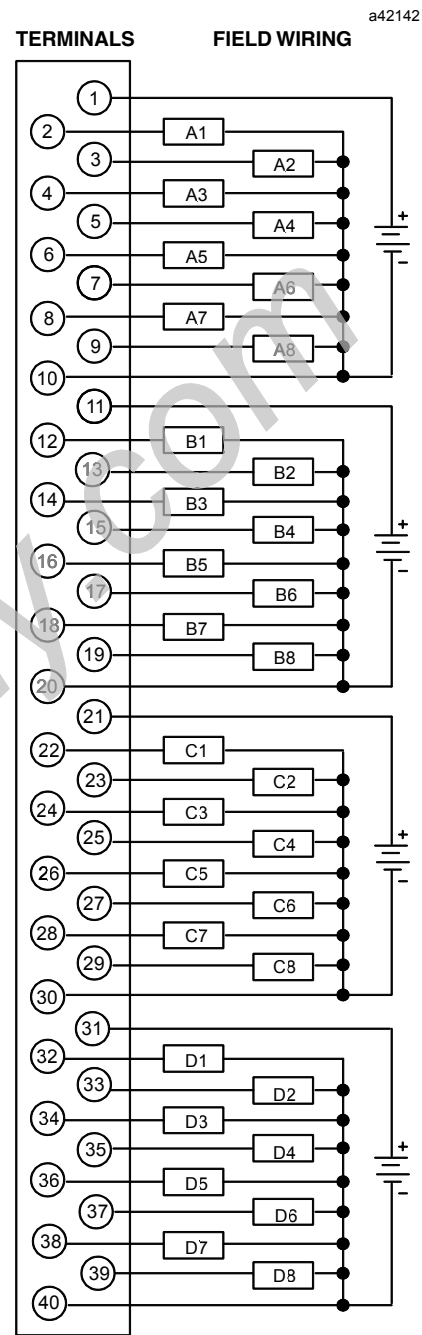

Figure 2. Field Wiring Connections for IC697MDL750

GFK-0085G
August 1997

24/48 Volt DC, 0.5 Amp, 32-Point Output Module

Recommended Field Wiring Procedures

The following procedures are recommended when connecting field wiring to the detachable terminal

board on this input module. Module features referenced in the following procedures which are common to all IC697 I/O modules are illustrated in the following figure.

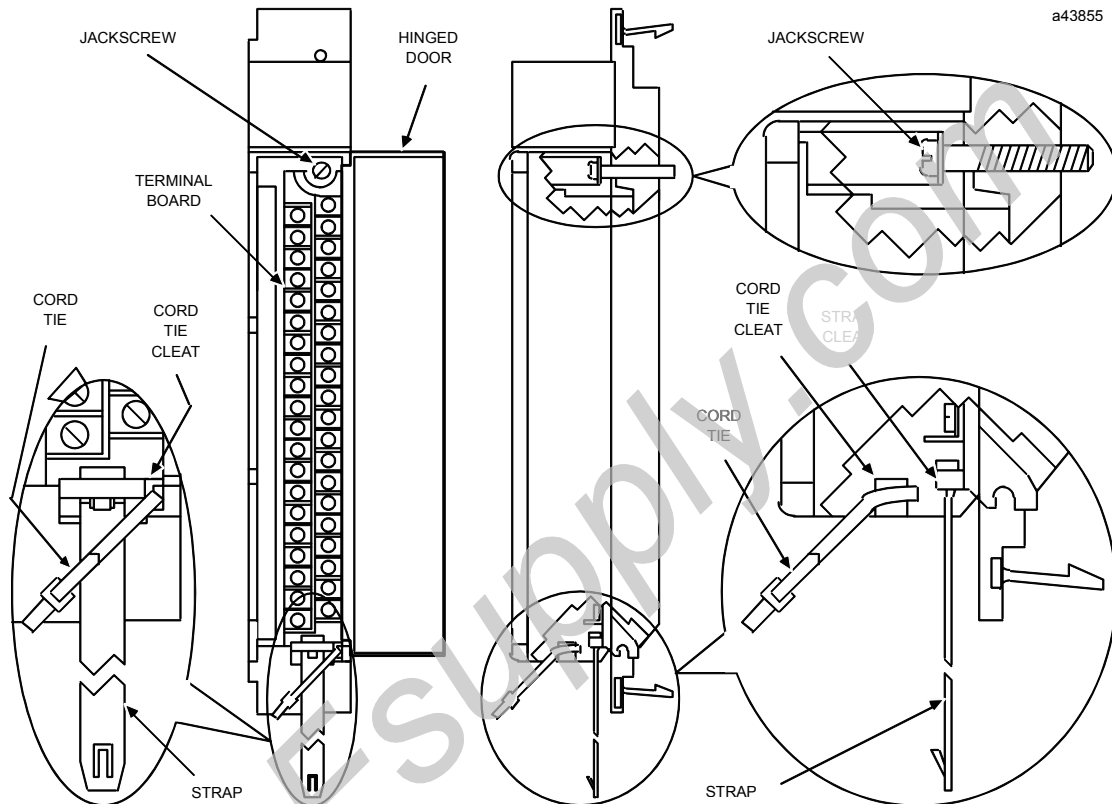

Figure 3. I/O Module Features

1. Turn off power before removing or installing terminal boards. Open the hinged door on the module to access a jackscrew which holds the terminal board securely in place. The detachable field wiring terminal board can now be removed from the module by turning the jackscrew counter-clockwise until it is fully disengaged.
2. To remove the terminal board, grasp the top of the terminal board and swing it outward.
3. The terminal board is designed to accept wire sizes from AWG #22 (0.36 mm^2) through AWG #14 (2.10 mm^2). It is important that when using AWG #14 (2.10 mm^2) wire for wiring all points, that a maximum insulation diameter of .135 inch (3.43mm) not be exceeded. To ensure proper connection, two wires may be terminated on any one terminal only if both wires are the same size.
4. The terminal board is designed to accept a maximum of (40) AWG #14 (2.10 mm^2) wires. If AWG #14 (2.10 mm^2) wires are to be used, then wire markers should be placed at least 8 inches (203 mm) from termination end to provide sufficient space for the hinged door to close.

Caution

Do not use the hinged door to remove the terminal board. The hinged door could be damaged if this is done.

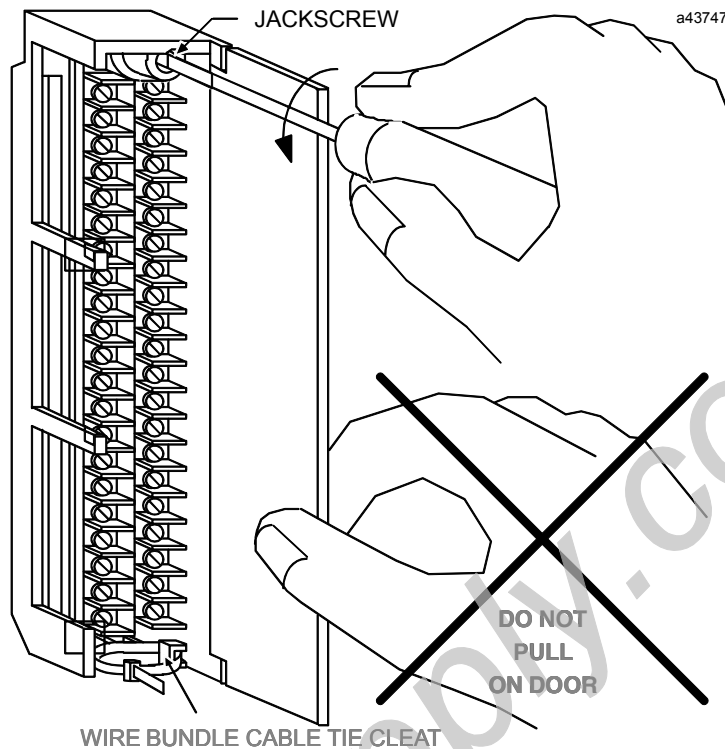

Figure 4. Removal of I/O Terminal Board

5. After completing connections to all modules in a rack, the wire bundle must be secured. To ensure that the wire bundle is secured properly, it is recommended that a cable tie be wrapped around the wire bundle and tightly secured through the cable tie cleat located at the lower right corner of the terminal board. For extremely large wire bundles, additional cable ties should be used.
6. A door label insert is included with each module to indicate circuit wiring information and provide space to record user circuit wiring identification. A slot is provided on the hinged door to allow for insertion of this label. If the label is difficult to insert, crease the scored edge before insertion. The outside label has a color coded stripe to allow quick identification of the module voltage type (blue: low voltage; red: high voltage).
7. After field wiring is completed, the terminal board should be securely fastened to the rack by inserting the terminal board strap (attached to each module) into the small rectangular slots in the bottom card guide grill on the rack. This strap not only secures

the terminal board to the rack, it also provides a way of identifying the wired terminal board with its correct mating rack slot location.

8. For adequate module ventilation, it is recommended that at least a 6 inch (152mm) clearance be allowed above and below the rack grill. Wire bundles should not obstruct the rack grill work.

Removing an I/O Module

The instructions below should be followed when removing an I/O module from its slot in a rack.

- Grasp the board firmly at the top and bottom of the board cover with your thumbs on the front of the cover and your fingers on the plastic clips on the back of the cover.
- Squeeze the rack clips on the back of the cover with your fingers to disengage the clip from the rack rail and pull the board firmly to remove it from the backplane connector.
- Slide the board along the card guide and remove it from the rack.

GFK-0085G
August 1997

24/48 Volt DC, 0.5 Amp, 32-Point Output Module

Table 1. Specifications for IC697MDL750 †

Rated Voltage:	24 or 48 volts DC
Outputs per Module:	32 (four groups of 8 outputs each)
Isolation:	1500 volts - any output to backplane 500 volts between input groups
Output Voltage Range:	20 to 60 volts
Output Current:	0.5 amps maximum per point 2 amps maximum per group
Output Characteristics	
Inrush Current:	10 amps maximum for 20 ms
Output Voltage Drop:	1 volt (2 ohms) maximum
Response Time-On:	1 ms maximum
Response Time-Off:	1 ms maximum
Output Leakage:	1 mA maximum
Current Required from 5V Bus:	0.25 amp
VME	System designed to support the VME standard C.1

† Refer to GFK-0867B, or later for product standards and general specifications. For installations requiring compliance to more stringent requirements (for example, FCC or European Union Directives), refer to *Installation Requirements for Conformance to Standards*.

Table 2. Ordering Information

Description	Catalog Number
Output Module, 24/48VDC 0.5 Amp, 32 points	IC697MDL750

Note: For Conformal Coat option, or Low Temperature Testing option please consult the factory for price and availability.