

GE Fanuc IC695ALG412

<http://www.pdfsupply.com/automation/ge-fanuc/rx3i-pacsystem/IC695ALG412>

Rx3i PacSystem

GE IP High Speed 12 channel isolated thermocouple module

919-535-3180

sales@pdfsupply.com

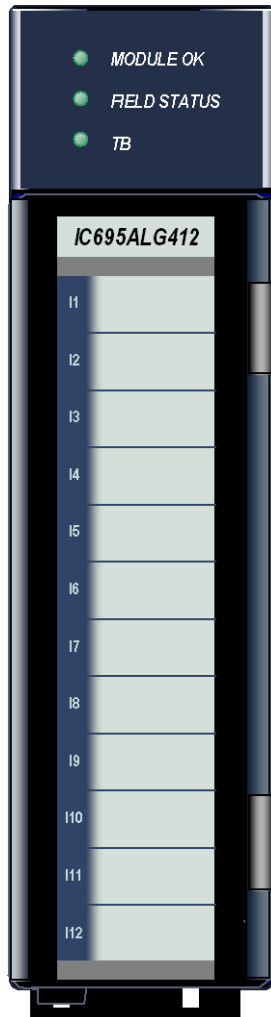

The PACSystems* **Thermocouple Input** module IC695ALG412 provides twelve isolated differential thermocouple input channels. The ALG412 offers a 10dB improvement in noise rejection compared to the ALG312 thermocouple input module.

Each channel can be individually configured for inputs from:

- Thermocouple types: J, K, T, E, R, S, B, N, or C
- Voltage: $\pm 50\text{mV}$

The module must be located in an RX3i Universal Backplane.

These modules can be used with a Box-style (IC694TBB032), Extended Box-style (IC694TBB132), Spring-style (IC694TBS032), or Extended Spring-style (IC694TBS132) Terminal Block. Extended terminal blocks provide the extra shroud depth needed for shielded wiring. See the *PACSystems RX3i System Manual*, GFK-2314 revision B or later for more information about Terminal Blocks. Terminal Blocks are ordered separately.

Module Features

- Completely software-configurable, no module jumpers to set.
- Thermocouple Linearization based on ITS-90.
- Supports hot removal and insertion (with system power applied).
- 32-bit IEEE floating point or 16 bit integer (in 32 bit field) input data format selectable per channel.
- Temperature units selectable in degrees C and F.
- User scaling.
- Programmable notch filter from 2.3 Hz to 28 Hz per channel.
- Under range/Over range alarm detection and reporting by channel.
- Alarm dead band for high alarm, low alarm, high-high alarm, and low-low alarm by channel.
- Wire-off (open circuit) condition support for all inputs.
- Module fault status reporting (Watchdog, RAM Fail, Flash Fail).
- Module identity and status reporting including LED status indicators.
- Supports Cold Junction Compensation (CJC) on Terminal Block (Cold Junction Sensors sold separately).
- User offset for all channels including CJCs.
- Support field upgrade of firmware application code.
- Optional CJC enable selections.
- Reports CJC temperatures as separate channels in Input Data.
- CJC update rate is fixed at 20Hz.
- CJC filter setting fixed with first notch at 60Hz, and 3dB input attenuation at 26.5 Hz.
- Terminal Block detection switch.

* indicates a trademark of GE Intelligent Platforms, Inc. and/or its affiliates. All other trademarks are the property of their respective owners.

GFK-2578C

Isolated +24 VDC Power

The module requires an external source of isolated +24 VDC. The external source must be connected via the TB1 connector on the left side of the RX3i Universal Backplane (IC695CHSxxx). For details on TB1, refer to “Universal Backplane Terminals (TB1)” in the *PACSystems RX3i System Manual*, GFK-2314.

Specifications

Refer to the *PACSystems RX3i System Manual*, GFK-2314, for product standards and general specifications.

Specification	Description			
Number of Channels	12 Individually isolated channels			
Resolution	11.5–16 bits (see filter table)			
Measuring method selectable per channel	Voltage: $\pm 50\text{mV}$ Thermocouple types: J, K, T, E, R, S, B, N and C			
Integration time for 12 channels	Configurable from 15 msec to 120 msec.			
Voltage Accuracy over temperature span	$\pm 0.1\%$ of voltage span at 25 °C. $\pm 0.25\%$ of span over temperature range.			
Thermocouple Input Types and Ranges	Thermocouple Type	Temperature Range		
	Type B	+300 to +1820		
	Type C	0 to +2315		
	Type E	-270 to +1000		
	Type J	-210 to +1200		
	Type K	-250 to +1372		
	Type N	-210 to +1300		
	Type R	0 to +1768		
	Type S	0 to +1768		
Type T	-270 to +400			
Voltage Input Ranges	Input Type	Voltage Range		
	-50mV to +50mV	-55.0 mV to +55.0 mV		
Module temperature accuracy for thermocouple inputs over temperature span (Does not include cold junction compensation or thermocouple tolerances) Module accuracy at (2.3, 4, 4.7 and 8 Hz filters):	Thermocouple Type & Range	+25°C	5°C–45°C	0°C–60°C
	Type J (-180°C to +1200°C)	$\pm 0.6^\circ\text{C}$	$\pm 1.25^\circ\text{C}$	$\pm 2.3^\circ\text{C}$
	Type J (-210°C to -180°C)	$\pm 0.8^\circ\text{C}$	$\pm 1.6^\circ$	$\pm 3.3^\circ\text{C}$
	Type N (-160°C to +1300°C)	$\pm 1.0^\circ\text{C}$	$\pm 2.0^\circ\text{C}$	$\pm 4.5^\circ\text{C}$
	Type N (-210°C to -160°C)	$\pm 1.8^\circ\text{C}$	$\pm 3.6^\circ\text{C}$	$\pm 8.0^\circ\text{C}$
	Type T (-190°C to +400°C)	$\pm 0.9^\circ\text{C}$	$\pm 1.8^\circ\text{C}$	$\pm 4.0^\circ\text{C}$
	Type T (-270°C to -190°C)	$\pm 6.7^\circ\text{C}$	$\pm 13.4^\circ\text{C}$	$\pm 18.0^\circ\text{C}$
	Type K (-200°C to +1372°C)	$\pm 1.0^\circ\text{C}$	$\pm 2.0^\circ\text{C}$	$\pm 4.0^\circ\text{C}$
	Type K (-250°C to -200°C):	$\pm 5.1^\circ\text{C}$	$\pm 9.5^\circ\text{C}$	$\pm 21.0^\circ\text{C}$
	Type E (-200°C to +1000°C)	$\pm 0.6^\circ\text{C}$	$\pm 1.2^\circ\text{C}$	$\pm 2.5^\circ\text{C}$
	Type E (-270°C to -200°C)	$\pm 5.3^\circ\text{C}$	$\pm 10.6^\circ\text{C}$	$\pm 14.0^\circ\text{C}$
	Type S and R	$\pm 2.8^\circ\text{C}$	$\pm 5.6^\circ\text{C}$	$\pm 11.5^\circ\text{C}$
	Type C	$\pm 1.7^\circ\text{C}$	$\pm 3.4^\circ\text{C}$	$\pm 7.0^\circ\text{C}$
Type B	$\pm 3.3^\circ\text{C}$	$\pm 6.6^\circ\text{C}$	$\pm 20.0^\circ\text{C}$	
Measurement Units	Degrees C or F, or Voltage			
CJC measurement resolution	0.01° (C or F) for temperatures 0-60°C			
CJC Temperature Accuracy	$\pm 1.5^\circ\text{C}$ Typical (0-60°C), $\pm 3.0^\circ\text{C}$ Max (0-60°C) when using IC695ACC600A or B (with an accuracy of $\pm 0.3^\circ\text{C}$)			
Repeatability	0.05% of voltage span at a constant temperature over a 30-second period			

Specification		Description	
Diagnostics reported to the controller		User configurable for Over Range, Under Range, High and Low Alarm, High-high and Low-low alarm, Open Circuit Detection, Positive and Negative Rate of Change alarm	
Channel-to-channel crosstalk		70 dB minimum	
Common Mode Rejection		All filters, 50/60 Hz: 110 dB	
Default or Hold Last State		Configurable per channel for Default to 0 or Hold Last State	
Fault Reporting		Configurable per channel to enable or disable fault reporting for under or over range alarm, open circuit, rate of change alarm.	
Rate of change		Configurable per channel to enable/disable and specify positive and negative rate of change alarms.	
Channel Value Format		Configurable as 16-bit integer (in a 32-bit field) or 32-bit real number.	
Backplane Power Requirements		3.3V IC695ALG412 = 400mA 5.0V IC695ALG412 = 425mA	
Input Impedance		Voltage: >=500k ohm	
Power Dissipation within the module		IIC695ALG412 = 3.5W max	
Isolation Voltage (Field to Backplane and Channel to channel) (CJC inputs are not isolated from the backplane)		250VAC Continuous 1500VAC 1 minute 2550VDC 1 second	
Module Filter settings, update times, rejection and resolution	<i>Filter Frequency (-3dB frequency)</i>	<i>Update Time (milliseconds)</i>	<i>Normal Mode Noise Rejection at 50/60 Hz</i>
	2.3 Hz	120 (130 max)	80dB @ 50/60 Hz
	4.0 Hz	70 (80 max)	80dB @ 50 Hz, 65dB @ 60 Hz
	4.7 Hz	60 (70 max)	80dB @ 50/60 Hz
	8.0 Hz	30 (40ms max)	48dB @ 50 Hz; 28dB @ 60 Hz
	24.0 Hz	20 (30 max)	38dB @ 50 Hz
	28.0 Hz	15 (25 max)	38dB @ 60 Hz

Update Time

The channel update times include channel scan time and filter delay time. Each channel's update rate is independent of any channel's update rate.

Module update time is the time required for the module to sample and convert the input signals, and provide the resulting data values to the processor.

GFK-2578C

Module Resolution

The module resolution depends on the input type and the filter chosen. The following table summarizes the effective number of bits of resolution, by filter and input type. It is based on the full scale range of the input type. If integer format is used, the resolution is limited to 16 bits.

Input Type / Filter Setting		2.3Hz		4.0Hz		4.7Hz		8Hz		24Hz		28Hz	
		Bits	°C	Bits	°C	Bits	°C	Bits	°C	Bits	°C	Bits	°C
J	<-180°C	14.8	0.04	15.0	0.03	14.6	0.05	14.9	0.04	13.9	0.08	13.6	0.09
	>-180°C	14.9	0.04	14.9	0.04	15.2	0.03	15.2	0.03	14.4	0.05	14.0	0.07
K	<-200°C	13.8	0.06	13.5	0.08	13.1	0.10	13.0	0.11	11.7	0.27	10.9	0.48
	>-200°C	14.3	0.04	14.3	0.04	14.5	0.04	14.5	0.04	13.4	0.08	12.7	0.14
T	<-190°C	13.4	0.05	13.4	0.05	13.4	0.05	13.1	0.06	11.7	0.16	11.1	0.25
	>-190°C	15.2	0.01	15.0	0.02	15.0	0.02	15.1	0.02	14.0	0.03	13.5	0.05
E	<-200°C	14.5	0.04	14.4	0.05	14.0	0.06	14.3	0.05	13.4	0.09	12.7	0.15
	>-200°C	15.1	0.03	15.0	0.03	15.0	0.03	15.2	0.03	13.6	0.08	13.0	0.13
R		14.4	0.07	14.6	0.06	14.7	0.06	14.4	0.07	13.1	0.16	12.2	0.31
S		14.3	0.07	14.1	0.08	14.3	0.07	14.3	0.07	13.1	0.16	13.6	0.12
B		13.2	0.14	13.0	0.15	12.8	0.17	12.3	0.24	11.2	0.52	10.9	0.65
N	<-160°C	14.3	0.06	14.3	0.06	14.3	0.06	14.2	0.07	12.9	0.16	12.7	0.18
	>-160°C	14.9	0.04	14.9	0.04	15.0	0.04	14.9	0.04	13.9	0.08	13.3	0.13
C		14.1	0.11	13.9	0.13	14.1	0.11	14.3	0.10	13.2	0.2	12.8	0.26
Voltage ±50mV		17	(μV) 0.63	16.9	(μV) 0.7	16.1	(μV) 1.2	16.1	(μV) 1.2	14.2	(μV) 4.2	14.1	(μV) 4.6

Installation in Hazardous Areas

- EQUIPMENT LABELED WITH REFERENCE TO CLASS I, GROUPS A, B, C & D, DIV. 2 HAZARDOUS AREAS IS SUITABLE FOR USE IN CLASS I, DIVISION 2, GROUPS A, B, C, D OR NON-HAZARDOUS LOCATIONS ONLY
- WARNING - EXPLOSION HAZARD - SUBSTITUTION OF COMPONENTS MAY IMPAIR SUITABILITY FOR CLASS I, DIVISION 2;
- WARNING - EXPLOSION HAZARD - WHEN IN HAZARDOUS LOCATIONS, TURN OFF POWER BEFORE REPLACING OR WIRING MODULES; AND
- WARNING - EXPLOSION HAZARD - DO NOT DISCONNECT EQUIPMENT UNLESS POWER HAS BEEN SWITCHED OFF OR THE AREA IS KNOWN TO BE NONHAZARDOUS
- EQUIPMENT OF LESSER ENCLOSURE TYPE RATING MUST BE INSTALLED IN AN ENCLOSURE PROVIDING AT LEAST IP54 PROTECTION WHEN APPLIED IN CLASS I, ZONE 2 ENVIRONMENTS
- THIS DEVICE MUST BE USED WITH AN ATEX CERTIFIED BACKPLANE
- THE DEVICES SHALL PROVIDE EXTERNAL MEANS TO PREVENT THE RATED VOLTAGE BEING EXCEEDED BY TRANSIENT DISTURBANCES OF MORE THAN 40%

Module Data

The module reports its input channel data in its assigned input words, beginning at the configured Channel Value Reference Address. Each channel occupies 2 words (whether the channel is used or not). For details on module configuration, refer to the *PACSystems RX3i System Manual*, GFK-2314.

Channel Value Reference Address	Contains this Input	Channel Value Reference Address	Contains this Input
+0, 1	Channel 1	+16, 17	Channel 9
+2, 3	Channel 2	+18, 19	Channel 10
+4, 5	Channel 3	+20, 21	Channel 11
+6, 7	Channel 4	+22, 23	Channel 12
+8, 9	Channel 5	+24, 25	CJC1
+10, 11	Channel 6	+26, 27	CJC2
+12, 13	Channel 7		
+14, 15	Channel 8		

Depending on its configured Channel Value Format, each enabled channel reports a 32-bit floating point or 16-bit integer value to the CPU.

In the 16-bit integer mode, low word of the 32-bit channel data area contains the 16-bit integer channel value. The high word (upper 16-bits) of the 32-bit value are set with the sign extension of the 16-bit integer. This sign-extended upper word allows the 16-bit integer to be read as a 32-bit integer type in logic without losing the sign of the integer. If the 16-bit integer result is negative, the upper word in the 32-bit channel data has the value 0xFFFF. If the 16-bit integer result is positive, the upper word is 0x0000.

Channel Diagnostic Data

In addition to the input data from field devices, the module can be configured to report channel diagnostics status data to the CPU. The CPU stores this data at the module's configured Diagnostic Reference Address. Use of this feature is optional.

The diagnostics data for each channel occupies 2 words (whether the channel is used or not):

Diagnostic Reference Address	Contains Diagnostic Data for:	Diagnostic Reference Address	Contains Diagnostic Data for:
+0, 1	Channel 1	+16, 17	Channel 9
+2, 3	Channel 2	+18, 19	Channel 10
+4, 5	Channel 3	+20, 21	Channel 11
+6, 7	Channel 4	+22, 23	Channel 12
+8, 9	Channel 5	+24, 25	CJC1
+10, 11	Channel 6	+26, 27	CJC2
+12, 13	Channel 7		
+14, 15	Channel 8		

GFK-2578C

When a diagnostic bit equals 1, the alarm or fault condition is present on the channel. When a bit equals 0 the alarm or fault condition is either not present or detection is not enabled in the configuration for that channel. For each channel, the format of this data is:

Bit	Description
1	Low Alarm
2	High Alarm
3	Underrange
4	Overrange
5	Open Wire
6 – 16	Reserved (set to 0)
17	Low-Low Alarm
18	High-High Alarm
19	Negative Rate of Change Alarm
20	Positive Rate of Change Alarm
21 – 32	Reserved (set to 0)

Module Status Data

The module can optionally be configured to return 2 bits of module status data to the CPU. The CPU stores this data in the module's 32-bit configured Module Status Data reference area. To enable Module Status reporting, the Module Status Reference must be configured. During operation, the PLC must be in an I/O Enabled mode for the current Module Status to be scanned and updated in reference memory.

Bit	Description
1	Module OK (1 = OK, 0 = failure, or module is not present)
2	Terminal Block Present (1 = Present, 0 = Not present)
3–32	Reserved

Terminal Block Detection

Faults are logged in the CPU's I/O Fault table when the terminal block is inserted or removed from a configured module in the system. If a Terminal Block is not present while a configuration is being stored, a "Loss of terminal block" fault is logged.

LEDs

LED	Indicates
Module OK	Off: Module is not receiving power from the RX3i backplane, or the module has failed self-test. Solid Green: Module OK and configured. Blinking Green, rapidly: Module performing powerup sequence. Blinking Green, slowly: The module has not received configuration from the CPU. If configuration is not successful, the module will continue to blink in this mode.
Field Status	ON Green: No faults on any enabled channel, Terminal Block is present, and field power is present. ON Amber and TB Green: Terminal Block is installed, fault on at least one channel, or field power is not present. ON Amber and TB Red: Terminal Block not fully removed, field power still detected. OFF and TB Red: Terminal block not present and no field power is detected.
TB	ON Red: Terminal block not present or not fully seated. See above. ON Green: Terminal block is present. See above. OFF: No backplane power to module.

Field Wiring

The table below lists wiring connections for the Isolated Thermocouple Input Module. There are no shield terminals.

<i>Terminal</i>	<i>Assignment</i>	<i>Terminal</i>	<i>Assignment</i>
1	No Connect	19	No Connect
2	CJC1-IN+	20	No Connect
3	CJC1-IN-	21	No Connect
4	CH1+	22	CH7+
5	CH1-	23	CH7-
6	CH2+	24	CH8+
7	CH2-	25	CH8-
8	CH3+	26	CH9+
9	CH3-	27	CH9-
10	CH4+	28	CH10+
11	CH4-	29	CH10-
12	CH5+	30	CH11+
13	CH5-	31	CH11-
14	CH6+	32	CH12+
15	CH6-	33	CH12-
16	CJC2 IN+	34	No Connect
17	CJC2 IN-	35	No Connect
18	No Connect	36	No Connect

Thermocouple / Voltage

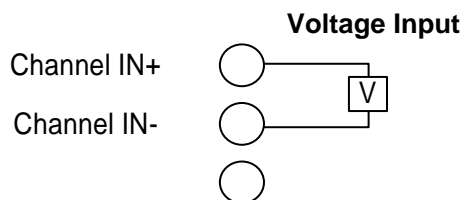

Depending on the Terminal block type chosen, the wire gauge supported ranges from 0.081...1.5mm² (28...14AWG) solid or stranded wire.

Grounding

There are no shield terminals on these modules. For shielding, tie cable shields to the ground bar along the bottom of the backplane. M3 tapped holes are provided in the ground bar for this purpose. **For optimal performance, thermocouple inputs should be ungrounded, and use shielded cable with the shield(s) grounded at the module end.** If a grounded thermocouple is required, a 0.1µF capacitor from the shield to the ground bar may be necessary on the module end to eliminate ground noise created from grounding both ends of the shield.

GFK-2578C

Installing CJC Sensors

When using thermocouple inputs, the use of CJC sensors is recommended. Installing one CJC sensor will greatly improve the accuracy of thermocouple readings. Installing two CJC sensors will provide the highest thermocouple input accuracy for the module. A CJC sensor compensates for offset voltages introduced into the input signal where the thermocouple wires are connected to the module. A set of two CJC sensors is available as part number IC695ACC600.

Under normal circumstances, adding one or both CJC sensors does not affect the channel or module scan times.

The thermistor end of the CJC sensor must be installed in the CJC1 IN+ or CJC2 IN+ terminal for accurate temperature measurements. The gold pin end of the CJC sensor must be installed in the CJC1 IN- or the CJC2 IN- terminal.

Open the Terminal Block contacts fully before installing the CJC sensor. Insert the sensor into the Terminal Block contact, maintaining metal-to-metal contact between the thermistor and the Terminal Block contact.

For a Box-style Terminal Block, maintain pressure while screwing down the contact.

Note: To use cold junction compensation, CJC scanning must be enabled in the module's hardware configuration.

For each CJC sensor used, the Open Wire diagnostic or fault report should be enabled in the CJC Channel configuration. This diagnostic will allow you to detect improper installation or a failed CJC sensor.

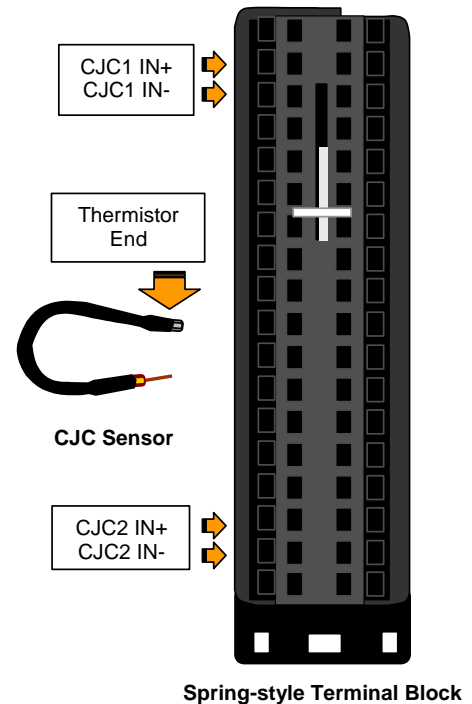

Release History

<i>Version</i>	<i>Firmware Revision</i>	<i>Comments</i>
IC695ALG412-BB	1.02	Hardware design updated to address component obsolescence. No change in functionality, performance, or compatibility.
IC695ALG412-AB	1.02	Improves accuracy of cold junction compensation and eliminates input glitches observed on some units. Also changes dual CJC scanning to revert to scanning a single operational CJC sensor in the event one of them fails instead of assuming 25°C for the failed sensor. Modified Type K Thermocouple low-end range from -270 °C to -250 °C.
IC695ALG412-AA	1.00	Initial Release

Important Product Information for this Release

Updates

The ALG412 can be field upgraded to firmware version 1.02 using upgrade kit 82A1726-MS10-000-A1. Upgrade kits can be downloaded at no charge from <http://www.ge-ip.com/support>.

Compatibility

The Thermocouple Input module requires the following CPU firmware and programming software versions:

CPU	RX3i CPU with firmware version 6.50 or later
Programmer	Machine Edition Logic Developer-PLC Version 6.50 or later must be used for configuration.

Operational Notes

<i>Issue</i>	<i>Description</i>
Channel values too high when CJC sensors not installed correctly	When CJC sensors are not installed correctly, or are missing, the open wire diagnostic or fault report for each CJC sensor channel must be enabled for the condition to be detected by the module. When enabled this condition will be reported in the I/O Fault Table and will also set the corresponding diagnostic status bit.