

## 7.6 Output Module, 12/24Vdc 2A Positive Logic 8-Point: IC694MDL730

The **12/24Vdc 2 Amp Positive Logic Output** module, IC694MDL730, provides one group of eight outputs with a common power output terminal. This module has positive logic characteristics; it sources current to the loads from the user common or positive power bus. The output device is connected between the negative power bus and the module output. The output characteristics are compatible with a wide range of load devices, such as: motor starters, solenoids, and indicators.

Individual numbered LEDs show the ON/OFF status of each output point.

The red LED (F) turns ON if either of the fuses blows. A load must be connected to the blown fuse for the indicator to light up. The module has two 5-Amp fuses with each fuse protecting four outputs: the first fuse protects A1 – A4; the second fuse protects A5 – A8. The fuses are electrically connected to the same common.

The blue bands on the label indicate that MDL730 is a low-voltage module.

This module can be installed in any I/O slot in an RX3i or Series 90 30 system.

Module supports insertion into and removal from an RX3i Universal Backplane which is under power. Refer to *Hot Insertion and Removal*, Section 2.6.4.1.

DC power to operate the field devices is supplied by the user.

### 7.6.1 LEDs

Output Status (1-8)	Green	Output is ON
	OFF	Output is OFF
Fuse (F)	OFF	Fuses are OK
	Red	One or more of the fuses is blown

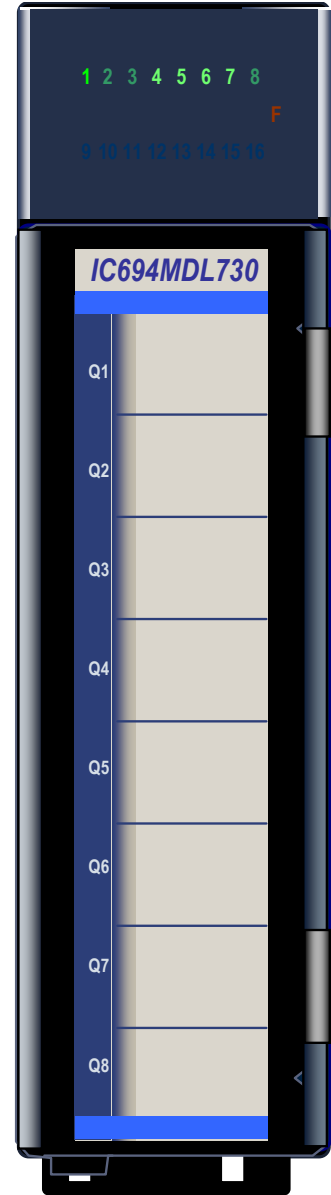

Figure 188: IC694MDL730

### 7.6.2 Specifications: MDL730

Rated Voltage	12/24 Vdc
Output Voltage Range	12 to 24 Vdc (+20%, -15%)
Outputs per Module	8 (one group of eight outputs)
Isolation	1500 volts between field side and logic side
Output Current <sup>21</sup>	2 Amps maximum per point 2 Amps maximum per fuse at 60°C (140°F) 4 Amps maximum per fuse at 50°C (122°F)
Output Characteristics	
Inrush Current	9.4 Amps for 10 ms
Output Voltage Drop	1.2 volt maximum
Off-state Leakage	1mA maximum
On Response Time	2ms maximum
Off Response Time	2ms maximum
Power Consumption	55mA (all outputs on) from 5Vdc bus on backplane

### 7.6.3 Thermal Derating MDL730

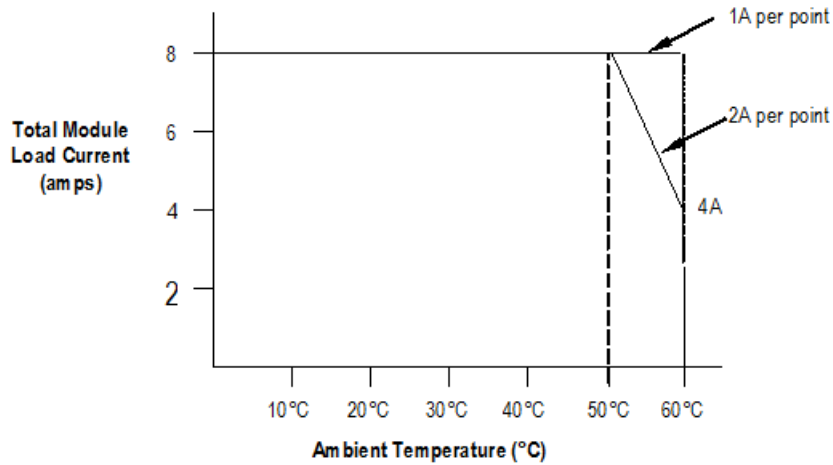

Figure 189: Thermal Derating Curve MDL730

<sup>21</sup> Maximum load current depends upon surrounding air temperature.

### 7.6.4 Field Wiring: MDL730

Field wiring connections to the module are made via the removable terminal assembly described below.

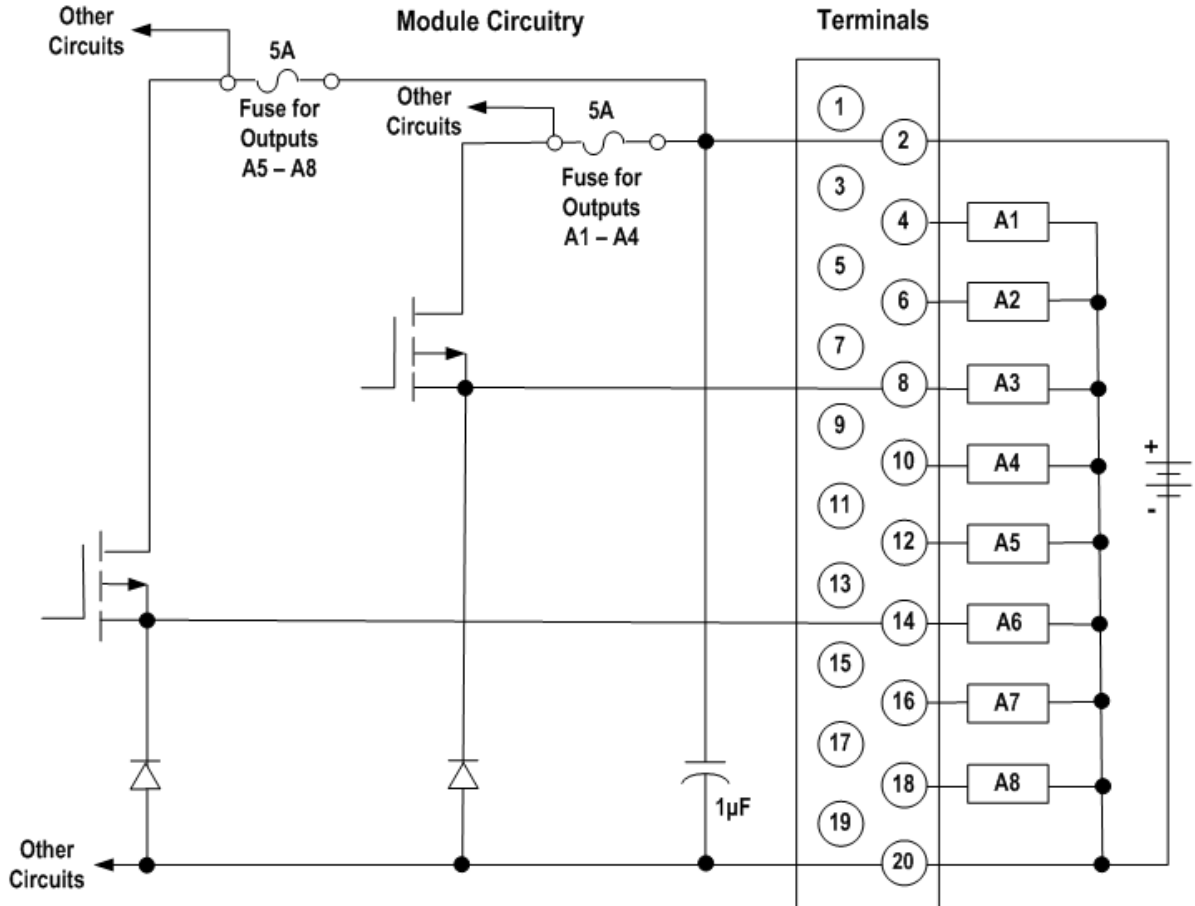

Figure 190: Field Wiring MDL730

#### 7.6.4.1 Terminal Assemblies

The MDL730 module has a special terminal assembly that is equipped with holding screws. These screws prevent the terminal assembly to module connections from deteriorating in applications where the controller is subject to severe vibration. To install these terminal assemblies, follow the standard installation instructions in Chapter 17, then tighten the two holding screws to 8 to 10 in-lbs (1 Nm).

Screw terminals accept two copper wires in the range AWG #22 (0.36 mm<sup>2</sup>) to AWG #16 (1.3 mm<sup>2</sup>), or one AWG #14 (2.1 mm<sup>2</sup>) copper 90°C (194°F) wire. Each terminal can accept solid or stranded wires, but the wires into any given terminal must be the same type (both solid or both stranded) and the same size. Screw torque is from 9.6 in-lbs to 11.5 in-lbs (1.1 Nm to 1.3 Nm).