

**IC670MDL742**

**New In Stock!**

**GE Fanuc**

<http://www.pdfsupply.com/automation/ge-fanuc/field-control/IC670MDL742>

**Field Control**

**1-919-535-3180**

In Stock! 5/12/24Vdc Neg. Logic Output, 16 Point IC670M  
IC670MD IC670MDL

[www.pdfsupply.com](http://www.pdfsupply.com)

**Email:** [sales@pdfsupply.com](mailto:sales@pdfsupply.com)

**Module Operation**

After checking the Board ID and verifying that the module is receiving appropriate logic power from the Bus Interface Unit (as reflected by the state of the module's Power LED), the Bus Interface Unit then sends output data to the module in serial format. During transmission, the module automatically loops this data back to the Bus Interface Unit for verification.

Serial to parallel converters convert this data into the parallel format needed by the module. Optoisolators isolate the module's logic components from field outputs. Power from the external power supply is used to drive the FETs that source current to the loads.

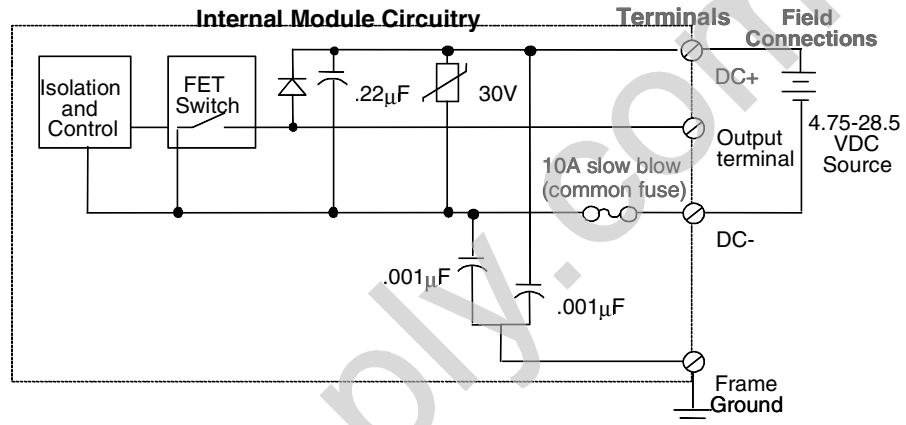

**Maximum Load Rating**

The outputs can switch loads over the range of 4.5 to 28.5 VDC and are capable of sinking up to a maximum of 0.5 Amp per point. The total maximum steady-state load for the entire module is 8 Amps.

**Caution**

**Failure to observe this maximum load guideline could result in misoperation or destruction of the module.**

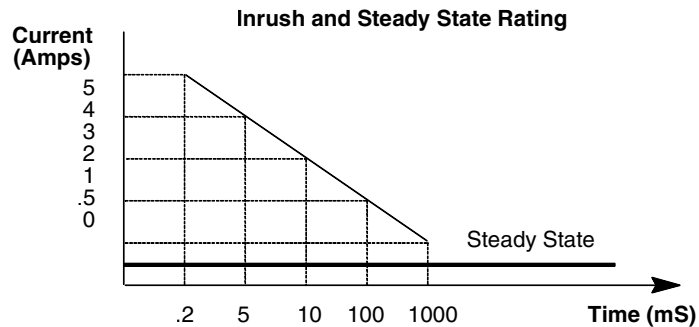

**Module Specifications**

<b>Module Characteristics</b>	
User Input Voltage	4.75 - 5.25 / 10.5 - 28.5 VDC, 8A maximum
Output Voltage Range	4.5 VDC to 28.25 VDC
Output Current	25mA maximum for 5-volt operation, 0.5 Amp maximum for 10.5 - 28.5 volt operation 8 Amps maximum per module 0.025A pilot duty at 4.75-5.25 VDC 0.5A pilot duty at 10.5-28.5 VDC
Outputs per module	16
Indicators	PWR LED indicates backplane power. Logic side LEDs indicate on/off status of each output; blown fuse fault and user supply below 4.2 VDC.
Isolation: User input to logic, user input to frame ground, group to group	250 VAC continuous, 1500 VAC for 1 minute. No isolation between individual points in a group.
Current Drawn from Bus Interface Unit Power Supply	111 mA maximum
<b>Output Characteristics</b>	
Inrush Current	2A max. for 100mS (see Inrush and Steady State diagram)
On state voltage: -5 volts -10.5 - 28.5 volts	0.25V maximum at 25mA maximum 0.25V maximum at 0.5 Amp maximum
Minimum Load Current	1 mA per point
Output Voltage Drop	0.25 volts maximum at rated currents
Output Leakage Current	250 $\mu$ A at 28.5 VDC
Response Time-On	200 $\mu$ s maximum with 0.5A resistive load
Response Time-Off	200 $\mu$ s maximum with 0.5A resistive load
Protection (each output)	Fuse: Metric 5 x 20 mm - 10 Amp, 250 V, Slow Acting Common to all outputs

**Module Fuse**

The module's 10 Amp fuse protects outputs against the effects of polarity reversal of the external power supply or excessive current through the output points. If incorrect connection of the power supply blows the fuse, it is indicated by the module's PWR LED. In addition, the module provides a Blown Fuse diagnostic message to the BIU. IF the fuse blows, disconnect power, remove the module and replace the fuse. *CAUTION: Electrostatic discharge can damage the module when it is not installed on an I/O Terminal Block. Always observe normal ESD protection practices when handling an un-installed module.*

Fuse location is shown below. Pry the fuse upward to remove it, taking care not to damage any components in the module. Place the new fuse in position and press it into the holder.

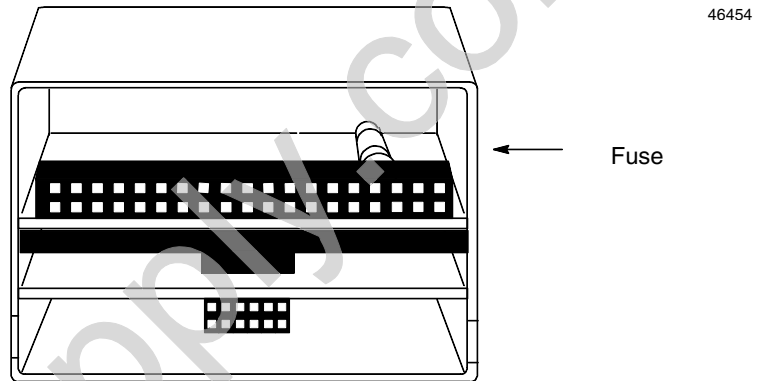

**Keying Locations**

Optional keying locations for the 5/12/24 VDC Negative Output Module are shown below.

Keying Locations									
A	B	C	D	E	F	G	H	J	K
x	x						x		x

### Field Wiring

The Terminal Block with box terminals has 25 terminals for each module, each of which accommodates one AWG #14 (avg 2.1mm<sup>2</sup> cross section) to AWG #22 (avg 0.36mm<sup>2</sup> cross section) wire, or two wires up to AWG #18 (avg. 0.86mm<sup>2</sup> cross section). When an external jumper is used, the wire capacity is reduced from AWG #14 (2.10mm<sup>2</sup>) to AWG #16 (1.32mm<sup>2</sup>).

The I/O Terminal Block with barrier terminals has 18 terminals per module. Each terminal can accommodate one or two wires up to AWG #14 (avg 2.1mm<sup>2</sup> cross section).

The I/O Terminal Block with Connectors has one 20-pin male connector per module.

The following illustration shows terminal assignments for the 15/12/24 VDC Negative Output Module.

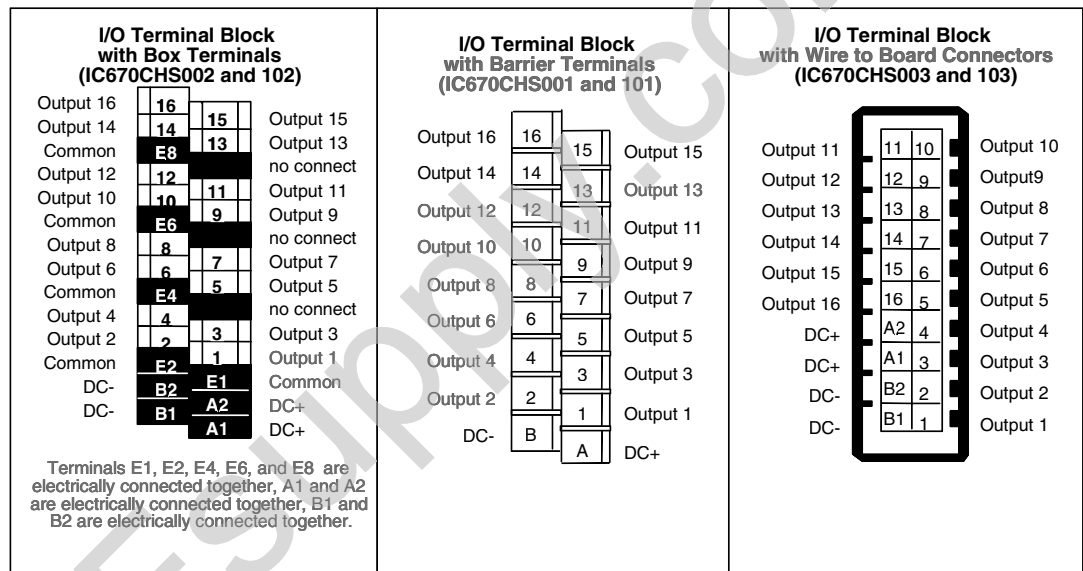

**Wiring Examples with Auxiliary Terminal Blocks**

If the module is installed on an I/O Terminal Block with Barrier Terminals, an Auxiliary Terminal Block can be used to provide additional wiring terminals. For the I/O Terminal Block with Wire to Board Connectors, external connection points are usually preferred, although an Auxiliary Terminal Block can be used..

Auxiliary Terminal Blocks have all terminals connected together internally. The Auxiliary Terminal Block with box terminals has 13 terminals, each of which accommodates one AWG #14 (avg 2.1mm<sup>2</sup> cross section) to AWG #22 (avg 0.36mm<sup>2</sup> cross section) wire, or two wires up to AWG #18 (avg. 0.86mm<sup>2</sup> cross section). The Auxiliary Terminal Block with barrier terminals has nine terminals, each of which can accommodate one or two wires up to AWG #14 (avg 2.1mm<sup>2</sup> cross section).

The following illustration shows how an optional Auxiliary Terminal Block with Box Terminals can be used for power connections when installing this module on an I/O Terminal Block with Box Terminals.

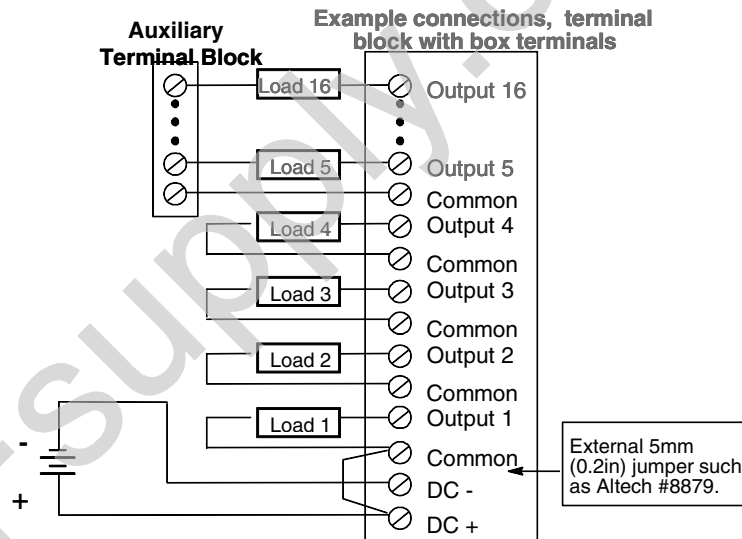

For an I/O Terminal Block with Barrier Terminals or an I/O Terminal Block with Wire to Board Connectors, an Auxiliary Terminal Block with Barrier Terminals might be connected as shown in the following example.

