

IC660EBD101
New In Stock!
GE Fanuc

<http://www.pdfsupply.com/automation/ge-fanuc/genius-io/IC660EBD101>

Genius IO
1-919-535-3180

In Stock! Electronic Assembly for IC660E IC660EB IC660EBD

www.pdfsupply.com

Email: sales@pdfsupply.com

Specifications

Block type: Catalog Numbers: Block: Terminal Assembly only: Electronics Assembly only:	8 circuit combination input and output IC660BBD101 IC660TSD100 IC660EBD101
Size (height x width x depth): Weight: LED's (I/O block): LED's (each circuit): Block to Block Isolation: Heat Dissipation:	8.83" (22.44cm) x 3.50" (8.89cm) x 3.94" (10.00cm) 4 lbs. (1.8 kg) Unit OK, I/O Enabled On logic side of switch 1500 V 16W maximum with 8 inputs 43.5W maximum with 8 outputs on at 2 amps.
Standby power (all inputs and outputs off): Operating voltage (single source): Frequency: Power supply dropout time:	8.5 Watts 93–132 VAC 47–63 Hz 1 cycle (16.7mS at 60Hz, 20mS at 50Hz)
Input Characteristics: Non-tristate input, OFF state: Minimum voltage across input device (IN to H) Maximum leakage through input device Non-tristate input, ON state: Maximum voltage across input device (IN to H) Maximum switch current threshold Tristate input, OFF state: Acceptable voltage across input device (IN to H) Tristate input, ON state: Maximum voltage across input device (IN to H) Input load network: Resistor to N Capacitor to H Input processing time (typical) Selectable input filter times Input diagnostics	60 VRMS 1.5 mA 20 VRMS 6 mA RMS 16 VRMS–40 VRMS 4 VRMS 13K ohms .10 µf 2mS + filter 10 to 100mS in 10mS increments Open Wire, Overtemperature, Failed Switch
Output Characteristics: Circuit output current (steady state) Maximum inrush current up to 2 cycles Maximum inrush current 2–6 cycles Maximum block output current Output Leakage @ 115 VAC: Current at 0 volt output (OUT to N) Voltage at open output (OUT to N) Output switch (OFF to ON/ON to OFF) Maximum switching frequency Turn-on delay (maximum) Voltage drop (at 2 amps) Voltage drop (at 30 amps inrush) Recommended min. load, resistive (No Load disabled): Recommended min. load, inductive (No Load disabled): No Load enabled threshold Fusing Output diagnostics	2 amps RMS 25 amps peak 14 amps peak 15 amps at 35C, 7.5 amps at 60C < 7mA 65 volts Zero crossing Once per second (high inrush currents) 0.5 Hz + 1mS 2.5 volts 10 volts 25mA 40mA 50mA Internal electronic short circuit trip. 100ms long time trip Short Circuit, Overload, No Load, Failed Switch, Overtemperature
Environmental: Operating Temperature Storage Temperature Humidity Vibration	0 to +60 C (32 to +140 F) –40 to +100 C (–40 to +212 F) 5% to 95% (non-condensing) 5–10 Hz 0.2" (5.08mm) displacement, 10–200 Hz at 1G

Block Operation

An 8 Circuit Grouped I/O Block has eight identical circuits rated to operate at a nominal 115VAC.

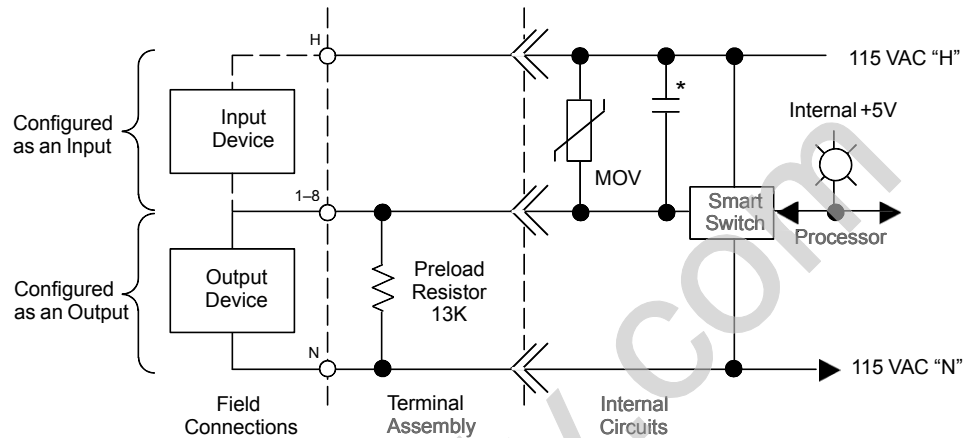

* .2 μ F for Block IC660BBD100
.1 μ F for Block IC660BBD101

Circuit LEDs

Each circuit has its own LED. If the circuit is configured as an input, the LED indicates the presence of threshold voltage at the input terminal. If the circuit is configured as an output, the LED indicates the state commanded by the CPU.

Inputs and Outputs

The block can be configured as combination input/output block, inputs-only or outputs-only blocks. Regardless, the block always broadcasts one byte of data each bus scan, and accepts one byte of data each bus scan.

If the block is configured as a combination block, circuits can be any mix of inputs and/or outputs. In this configuration, the block will use 8 input references and 8 output references. The actual state of each output circuit will be returned to the CPU in the corresponding input reference location. The CPU can monitor the feedback state to verify (after an appropriate delay) that the output switching device has operated properly and that the load has the proper voltage and current applied.

If the block is configured as an inputs-only block, all circuits must be regular inputs or tristate inputs. The block will use 8 input references and NO output references.

If the block is configured as an outputs-only block, all circuits must be outputs; no feedback analysis will be performed. The block will use 8 output references and NO input references.

Appendix B shows reference usage for a Series 90, Series Six, or Series Five PLC.

Input Data Format

A 115 VAC 8 Circuit Grouped I/O Block broadcasts 1 byte of input data each bus scan.

Byte #	Description
0	Inputs 1 – 8 (input 1 in bit 0)

Output Data Format

Byte #	Description
0	Outputs 1 – 8 (output 1 in bit 0)

The block receives 1 byte of output data from the bus controller each bus scan.

Hand-held Monitor I/O Display

The Hand-held Monitor displays the I/O types (line 3) and current states (line 4) of all circuits on the Monitor Block screen.

REF				1–		8	0
1	2	3	4	5	6	7	8
I	I	I	I	I	I	I	I
1	1	0	1	0	1	0	0

Individual circuits are displayed on the Monitor/Control Reference screen (which also shows a circuit's fault and force status).

Diagnostics

115 VAC 8 Circuit Grouped I/O Blocks perform the diagnostics described below. A block reports all faults to the Hand-held Monitor, and takes appropriate corrective action. Individual circuits can be configured not to send diagnostic messages to the CPU if a fault occurs. If the CPU requests diagnostic information from the block using Read Diagnostics datagrams, the block returns current diagnostics for all circuits, including any with CPU fault reporting disabled.

Overtemperature Diagnostic

Each circuit has a built-in thermal sensor. If the block's internal temperature exceeds 100C, the block sends an OVERTEMPERATURE message and turns off the circuit to protect its internal electronics. This diagnostic is always performed for both inputs and outputs.

Short Circuit Diagnostic

Automatic output diagnostic. Output circuits are protected by a short circuit level sensor at the switching device. If the instantaneous current on an output exceeds 30 amps during the first two line cycles or 20 amps thereafter, the block turns the output off within microseconds. The block will try to restart the load; if several attempts are unsuccessful, the output circuit is forced off and the block sends a SHORT CIRCUIT message. To restore normal operation to output the cause of the current surge must be removed, then the diagnostic must be cleared from the HHM or the CPU.

Failed Switch Diagnostic

The block automatically monitors all circuits for several types of faults, which may be reported as Failed Switch diagnostics.

For an output, Failed Switch is reported if the circuit's switch state is not the same as its commanded state. The block sends a FAILED SWITCH message identifying the failed circuit. The logic state of the circuit is set to OFF.

When an output fault occurs, the actual condition of the output switch is not known. If the output switch has failed shorted (or closed), current flow is not interrupted when the block forces the output state OFF. Action external to the block must be taken to remedy the problem. The FAILED SWITCH message can alert personnel or cause program logic to be activated, possibly shutting off power to the block, I/O section, or process.

Note

False Failed Switch diagnostics may be reported if an external device like a manual switch is wired in parallel with an output. Even if Fault Reporting for the circuit is disabled, it will be necessary to clear each Failed Switch fault detected by the block. If the application requires such a configuration, 115VAC/125VDC Isolated I/O Block version IC660BBS101 (no Failed Switch diagnostic) should be used instead.

Several additional switch faults independent of the output state are detected and reported as Failed Switch faults on both input and output-configured circuits. Examples include loss of communications with the block's internal microprocessor and some internal power supply faults.

Open Wire Diagnostic

The block automatically performs this diagnostic on any circuit configured as a tristate input. It will detect an electrical (not mechanical) malfunction. In addition to being configured as a tristate input, the circuit must have a 5.1K ohm, 1/2 Watt or larger non-inductive resistor placed as close as possible to the actual dry contacts (such as across the field device terminals).

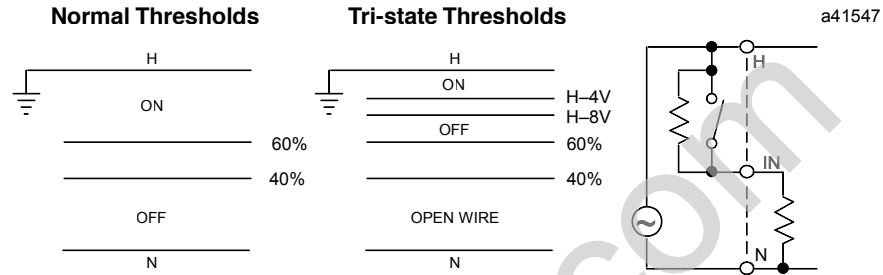

With the switch closed (ON state), the circuit senses the low source impedance. With the switch open (OFF state), the circuit senses the added resistance. If a wire is broken, cut or removed, impedance becomes very high. The block will transmit 0 as the state of the input, and send an OPEN WIRE message.

Since faulty input circuit option monitoring requires specific current flows, devices as photo-sensors, electronic high-speed counters, instrumentation, fiber optic sensors, and similar electronic devices cannot be monitored for Open Wire conditions. Such devices should be set up as standard, not tristate, inputs.

GE offers compatible input devices including a 5.1K ohm monitoring resistor with its line of General Purpose Control sensor devices.

No Load Diagnostic

The optional No Load diagnostic can be enabled or disabled for individual outputs.

For a new block, outputs are configured to report No-Load conditions. In this configuration, energizing the output activates a no-load current level. If the load does not continuously draw 50 mA from the output circuit, the block sends a NO LOAD message. Because this diagnostic monitors both current and voltage, a No Load condition may cause an HHM monitoring an operating block to display 0 for the circuit although there is voltage at the output and the circuit LED is on.

This diagnostic should be disabled for circuits on which very small loads (small relays, transformers, or indicating lamps) will draw less than 50 mA.

Overload Diagnostic

Like No-Load detection, this diagnostic is optional for individual outputs.

In addition to the protection provided by the block's built-in Short Circuit detection, Overload Shutdown provides further protection for output loads, field wiring, and switching devices. If a load exceeds 2.8 amps (2.0 amps RMS) continuously for 100mS, the block will turn the output off and send an OVERLOAD message if Overload Shutdown is enabled.

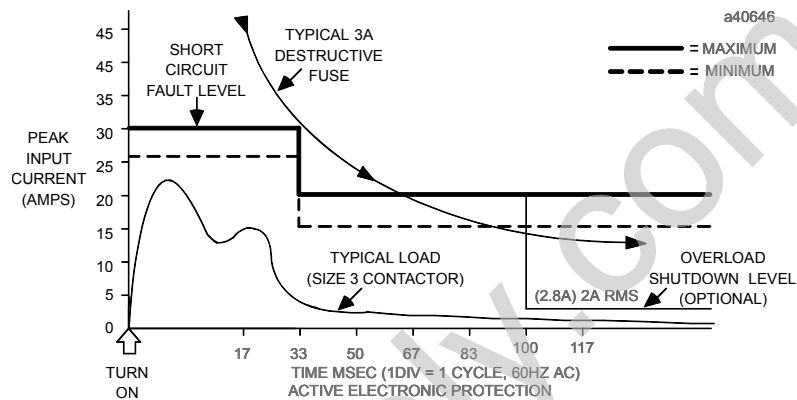

For loads that require more than 2 amps RMS, individual outputs can be configured not to shut off at this level or send the OVERLOAD message. These restrictions apply:

1. Maximum load current: 10 amps RMS
2. Maximum duty cycle: limit duty cycle so that: (Load current) x (% ON) is less than 1.0 amp.
3. Maximum ON time: 1 minute
4. Maximum total current of all outputs ON at the same time is less than 15 amps.

For example, a maximum 10 amp load can be pulsed at a 10% duty cycle, or up to 1 minute ON and 9 minutes OFF. Higher repetition rates can be used if the duty cycle is maintained. Exceeding the 10 amp limit may cause a short circuit fault to be generated. The duty cycle derating to an average of 1 amp output current and the ON time limit are necessary to avoid overheating due to the increased power dissipation in the block at these high currents. Exceeding these limits may cause an overtemperature fault.

Field Wiring

Field wiring connections are standard screw, clamp-type terminals which can be operated with a flat or phillips-head screwdriver. Each terminal accepts one AWG #12 or two AWG #14 wires. The minimum recommended wire size is AWG #22. The terminals can accommodate spade or ring terminals up to 0.27 inch (6.85 mm) in width with a minimum opening for a #6 screw, and up to 0.20 inch (5.1 mm) depth from the screw center to the back barrier. Be sure unshielded wire ends are not longer than 2 inches (5 cm).

Connect neutral to an N terminal. All H terminals are internally bussed, as are all N terminals. Extra power terminals are for convenience. Depending on the physical layout and current loads, hot connections can be bussed together and made by one wire to the block or power source. Neutral connections can also be bussed together and made by one wire.

Any circuit can be an input or output. The power source is connected through an input device (such as a switch) to a discrete input circuit on the block. For outputs, power is routed through the block electronics to a discrete circuit and applied to a load. The load return connects to the N terminal.

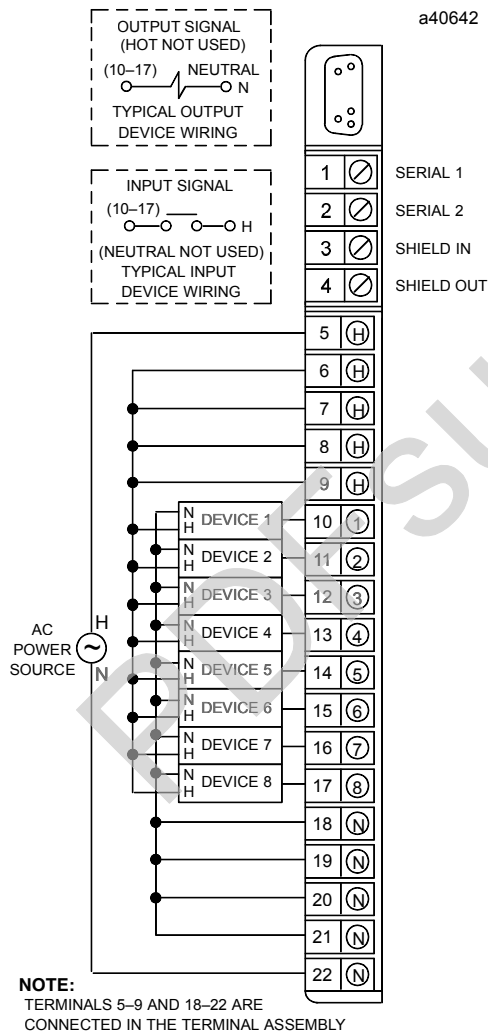

Wiring for Tristate Inputs

If an input circuit should report open wire conditions, install a 5.1K ohm, 1/2 Watt or larger non-inductive resistor across the dry contacts of the input device. The same circuit must be configured as a Tristate Input.

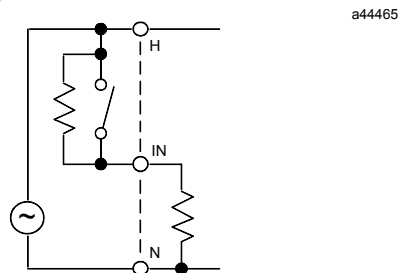

Added Resistance for Small Loads

Block IC660BBD101 drives small loads without added resistance. For block IC660BBD100, it may be necessary to add resistance for loads drawing less than 50mA. See page 2-10 for more information.

Wiring for a Bus Switching Module

If the block will be a BSM Controller, attach the BSM like a load to circuit 1. Connect either BSM pigtail wire to terminal 10, and the other to an N terminal.

Connect a 115 volt AC source to one of the H terminals on the terminal strip.

Block Power

Make all power connections on the block to the same 120 VAC phase. Different blocks can have different phases between them.

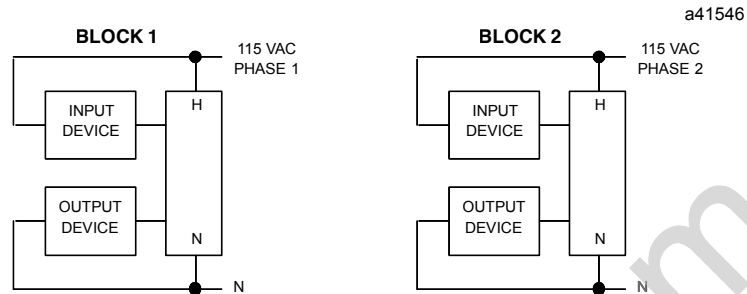

Block Power Disconnects

Since block power is the same as circuit power, it is important to wire block power disconnects so that block power and input power will be removed *at the same time*.

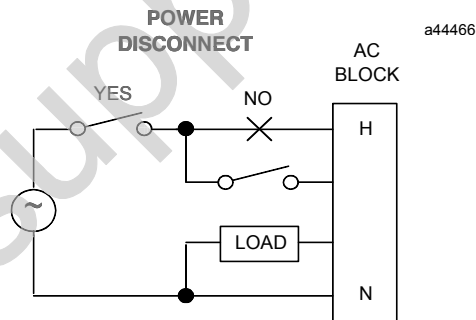

Caution

If input power is not removed when block power is removed, the block may power up when multiple inputs are activated, even though one leg of power has been removed from the block.

Block Configuration

Configurable features are listed below. For many, the factory setting may not need to be changed.

Feature	Circuit or Block	Factory Setting	Selections
Device Number*	Block	null	0 to 31 (a number must be selected)
Reference Address*	Block	none	Depends on host CPU type
Block I/O Type*	Block	input	input, output, combination
Baud Rate*	Block	153.6 std	153.6 std, 153.6 ext, 76.8, 38.4 Kbd
Pulse Test for Outputs	Block	enabled	enabled, disabled
Input Filter Time	Block	20mSec	10–100mSec in 10mS steps
Circuit I/O Type	Circuit	input	input, output, tristate input
Report Faults	Circuit	yes	yes, no
Hold Last State	Circuit	no	yes, no
Output Default State	Circuit	off	on, off
Report No Load	Circuit	yes	yes, no
Overload Shutdown	Circuit	yes	yes, no
BSM Present	Block	no	yes, no
BSM Controller	Block	no	yes, no
Output Default Time	Block	3 bus scans	(for bus redundancy) 2.5 or 10 sec
CPU Redundancy	Block	none	none, hot standby, duplex
Duplex Default	Block	off	on, off
Configuration Protection	Block	disabled	enabled, disabled

Features marked with an asterisk in the table are configured from the Program Block ID screen of the Hand-held Monitor, as explained in chapter 3.

The rest of the features can be configured either using a Hand-held Monitor, or by sending a Write Configuration datagram to the block from the host.

Before configuration begins, the block's features should be decided on and recorded on a copy of the Configuration Worksheet printed on the next page.

Note

If the block will be used on a bus *controlled* by a Series Five PLC or a host computer and the block will be configured as an all-inputs block, the GENI daughterboard on the Series Five bus controller or computer bus interface module must be version 1.5 or later. If not, the block cannot be used as a BSM Controller, and its I/O Enabled LED will not operate properly.

The daughterboard can be upgraded using kit 44A286366-G03 (or later).

115 VAC 8 Circuit Grouped I/O Blocks Configuration Worksheet

Block _____ Location _____

Block Features:

Configuration Protected (Y/N) _____

Block Number (0–31) _____ Block Type (Input/Output/Combination) _____

Reference Address _____ through _____

Baud Rate (153.6 Kb Std/153.6 Kb Ext/76.8 Kb/38.4 Kb) _____

Pulse Test (Enabled/Disabled) _____ Input Filter Time (10–100) mS _____

Redundancy Features:

Redundancy Mode (None/Standby/Duplex) _____ Duplex Default (on/off) _____

BSM Present (Y/N) _____ BSM Controller (Y/N) _____ Outputs Default (2.5/10 sec) _____

Circuit Features:

Ckt #	Reference Number	I/O Type (I/O/I _T *)	Report Faults (yes/no)	(output) Hold Last State (yes/no)	(output) Default State (ON/OFF)	(output) Report No Load (yes/no)	(output) Overload Shutdown (yes/no)
1	_____	_____	_____	_____	_____	_____	_____
2	_____	_____	_____	_____	_____	_____	_____
3	_____	_____	_____	_____	_____	_____	_____
4	_____	_____	_____	_____	_____	_____	_____
5	_____	_____	_____	_____	_____	_____	_____
6	_____	_____	_____	_____	_____	_____	_____
7	_____	_____	_____	_____	_____	_____	_____
8	_____	_____	_____	_____	_____	_____	_____

* I_T (Tristate Input) must have 5.1K Ω resistor across dry contacts of input device

Pulse Test

A new block is configured to enable Pulse Testing (see below). Pulse Testing should remain enabled if the block has loads that hold one state for long periods of time, *unless any load(s) are sensitive to pulses or interruptions of up to 8mS*. It should be disabled if the block's loads will normally change state as the program executes. These outputs will report faults during normal operation, and do not need to be pulsed.

Hand-held Monitor Configuration Steps

```

PULSE TEST
REF
ENABLED
  tgl entr nxt
  
```

1. Line 3 of the Pulse Test screen shows whether the feature is currently enabled for the block. If you want to change the selection, press F2 (tgl).
2. Press F3 (enter).
3. Press F4 (next) to advance to the next configuration display.

Pulse Testing Outputs

Outputs can be pulse-tested from a Hand-held Monitor or by sending a Pulse Test command from the application program.

Pulse Testing tests the continuity of each output circuit including the switch device, power source, wiring, interposing devices (fuses, circuit breakers, terminals), and output device. It works whether or not there is minimum current to check for a No-Load condition. Pulse testing does not activate mechanical devices such as motor starters, relays, or solenoid valves.

Pulse Testing should momentarily cause outputs that are OFF to turn ON and outputs that are ON to go OFF. Pulse testing may generate the following diagnostics:

Failed Switch: If the output does not change state when pulsed.

Short Circuit: If the load on an output that was OFF exceeds 30 amps when pulsed ON.

No Load: If the load on an output that was OFF draws less than 50 mA when pulsed ON.

If the output was OFF, no current flow when the output is pulsed indicates an open circuit or failed switch. Similarly, continued current flow when ON outputs are pulsed OFF indicates a shorted switch (both malfunctions are reported to the CPU).

Input Filter Time

The block continuously samples each input for the length of the configured input filter time period. If the input remains either ON or OFF during that time, the block recognizes its state. For example:

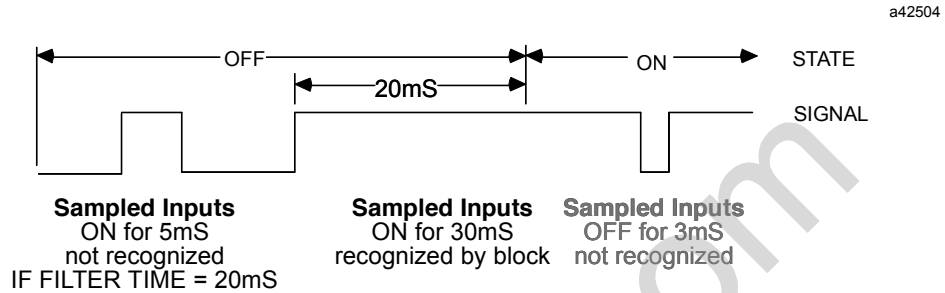

The input filter helps reject spurious noise spikes and multiple inputs generated by the bounce of mechanical devices. An input filter time of 10mS to 100mS can be selected for the block. The default filter time is 10mS (no filter).

In controlled, noise-free environments, signals generated by clean, solid state electronics may be unnecessarily slowed by a filter, delaying system response. In such an environment, no additional filter time is needed.

In noisy environments, use a longer filter time to prevent noise from possibly causing erratic or unsafe system operations.

For a block with tristate inputs, the minimum recommended Input Filter Time is 50mS.

Hand-held Monitor Configuration Steps

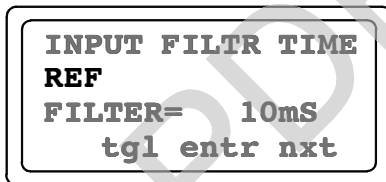

1. The screen displays the currently-selected filter time. If this time should be changed, press F2 (tgl) to display the other filter times.
2. To save a new selection, press F3 (entr).
3. Press F4 (next) to advance to the next configuration display.

I/O Circuit Type

Selecting Block I/O type (on the Program Block ID screen) determined whether the block would be an all-inputs, all-outputs, or combination block. The I/O type of each circuit is specified on the screen shown below. If you haven't selected the Block I/O Type, and the block should be an outputs-only or combination I/O block, see page 3-10 for instructions before continuing.

If the Block I/O Type selected was Combination, each circuit can now be configured as an input (I), output (O), or tristate input (IT). Select **Tristate Input** for any input circuit that should report the Open Wire diagnostic (resistance must be added at the input device).

If the Block I/O Type is all-inputs, each circuit can be either an regular input (I) or a tristate input (IT). Select **Tristate Input** for any input circuit that should report the Open Wire diagnostic.

If the Block I/O Type is all-outputs, each circuit must be an output (O).

Hand-held Monitor Configuration Steps

```
I/O CIRCUIT CFG
REF
ITITITIT I I I
> tgl entr nxt
```

1. Line 3 shows the I/O type of each circuit. To select a circuit, press F1 (>).
2. To change a circuit's I/O type, press F2 (tgl). To save the new selection, press F3 (entr).
3. Press F4 (next) to advance to the next configuration display.

Report Faults to CPU

Fault reports to the host can be disabled or enabled for any circuit.

If fault reporting is disabled, the block does not send fault reports to the CPU for that circuit. If fault reporting is enabled, the block sends a message to the host if any fault occurs on that circuit.

Regardless of whether fault *reporting* is enabled, the block detects faults on the circuit and takes appropriate action. If a fault occurs, the Unit OK LED blinks and a fault report is sent to a Hand-held Monitor. The fault condition must be corrected for proper operation of the block.

If the CPU requests diagnostic information from the block using Read Diagnostics datagrams, the block returns current diagnostics for all circuits, including any with CPU fault reporting disabled.

Hand-held Monitor Configuration Steps

```
REPORT FAULTS ?
REF
Y Y Y Y Y Y Y Y
  tgl entr nxt
```

1. The screen displays the current Fault Reports configuration of all circuits on the block.
2. To select a circuit for configuration, press F1 (>).
3. To change the Report Faults configuration of a circuit, press F2 (tgl). To save the new selection, press F3 (entr).
4. Press F4 (next) to advance to the next configuration display.

Hold Last State

Each output can be configured to either hold its last state or to go to its powerup default state if the block loses CPU communications for at least 3 bus scans.

For a new block, Hold Last State is disabled for each output. With Hold Last State disabled, the block sets the output to its powerup default if CPU communications are lost.

If Hold Last State is enabled, the block continues to hold the output in its current state instead of setting it to the powerup default.

Outputs remain in their last state or default indefinitely or until one of the following occurs:

- Communications with the CPU are restored.
- The Hand-held Monitor changes the output by forcing it.
- Power is removed from the block.

Hand-held Monitor Configuration Steps

```

HOLD LAST STATE?
REF
Y Y Y Y Y X X X
> tgl entr nxt

```

1. Line 3 shows the current Hold Last State configuration of each circuit:
 Y = hold last state.
 N = go to default state (configured on the next HHM screen)
 X = the circuit has been configured as an input.
2. To select a circuit, press F1 (>). To change the selection for a circuit, press F2 (tgl).
3. To save the new selection, press F3 (entr). Press F4 (next) when you are ready to advance to the next configuration display.

Output Default State

An output goes to its powerup default state when the block is first powered up.

If the Hold Last State feature is NOT enabled, the block also defaults the output if CPU communications are lost. On a non-redundant system, default occurs approximately 250mS after the third bus scan passes with no CPU communications. If the block is on a redundant bus downstream of a Bus Switching Module, more time is needed. Additional default time for redundancy is explained on page 4-19.

Hand-held Monitor Configuration Steps

```

OUTPUT DEFAULT
REF
0 0 1 1 1 X X X
> tgl entr nxt

```

1. Line 3 shows the Output Default State configuration of all circuits:
 0 = the output default state is off.
 1 = the output default state is on.
 X = the circuit has been configured as an input.
2. To select a circuit, press F1 (>).
3. To change the selection for a circuit, press F2 (tgl).
4. To save the new selection, press F3 (entr).
5. Press F4 (next) to advance to the next configuration display.

Report No Load

On a new block, each output is configured to report No-Load diagnostics. This diagnostic activates a no-load current level when the output is energized. If the load does not continuously draw 50mA from the output circuit, the block sends a NO LOAD message.

You should disable this diagnostic for any output where a very small load (small relay, transformer, or indicating lamp) will draw less than 50 mA.

Hand-held Monitor Configuration Steps

```

REPORT NO LOAD?
REF
Y Y Y N N X X X
> tgl entr nxt

```

1. Line 3 shows the Report No Load configuration of all circuits:
 Y = the output will report No Load conditions.
 N = the output will not report No Load conditions.
 X = the circuit has been configured as an input.
2. To select a circuit, press F1 (>).
3. To change the selection for a circuit, press F2 (tgl).
4. To save the new selection, press F3 (entr). Press F4 (next) when you are ready to advance to the next configuration display.

Overload Shutdown

The Overload Shutdown feature protects output loads, field wiring, and switching devices from excessive current. If a load exceeds 2.8 amps (2.0 amps RMS) continuously for 100mS and Overload Shutdown is enabled, the block turns the output off and sends an OVERLOAD message.

Under certain conditions (see page 4-7) Overload Shutdown detection and reporting can be disabled for output loads that require more than 2 amps RMS.

Hand-held Monitor Configuration Steps

```

OVRLD SHUTDWN?
REF
Y Y Y Y N X X X
> tgl entr nxt

```

1. Line 3 shows the Overload Shutdown configuration of all circuits:

Y = output will shut down and report diagnostic if overload occurs.

N = output will NOT shut down or report Overload diagnostic.

X = the circuit has been configured as an input.

2. To select a circuit, press F1 (>).
3. To change the selection for a circuit, press F2 (tgl).
4. To save the new selection, press F3 (entr).
5. Press F4 (nxt) when you are ready to advance to the next configuration display.

BSM Present

If the block is connected to a single bus or to just one trunk of a dual bus, BSM Present should be set to NO (the default).

Select YES if the block is located in a cluster connected to dual busses via a Bus Switching Module.

Hand-held Monitor Configuration Steps

```
BSM PRESENT ?  
REF  
STATUS = YES  
  tgl entr nxt
```

1. To change the BSM Present configuration, press F2 (tgl).
2. To save the new selection, press F3 (entr).
3. Press F4 (next) to advance to the next configuration display.

BSM Controller

A BSM Controller is a block to which a Bus Switching Module is directly attached, which controls the BSM's switching action. Selecting a block to be a BSM Controller block has no effect on the block's I/O type – the block can still be configured as an inputs-only block, but circuit #1 cannot be physically used as an input. The first circuit will not be under CPU control.

To change this configuration with a Hand-held Monitor, the block must first be configured for BSM PRESENT. The BSM CONTROLLER menu will not appear if BSM PRESENT is set to NO.

Hand-held Monitor Configuration Steps

```
BSM CONTROLLER?  
REF  
STATUS = NO  
  tgl entr nxt
```

1. To change the configuration, press F2 (tgl).
2. To save the new selection, press F3 (entr).
3. Press F4 (next) to advance to the next configuration display.

Output Default Time

When a Bus Switching Module is used, the Output Default Time must be long enough to allow the BSM to switch without causing outputs to default. Therefore, when BSM Present is selected (above), the block automatically changes its Output Default Time from 3 bus scans to 2.5 seconds.

If the Hold Last State feature is set to YES, outputs will remain in their last state while the BSM switches, instead of defaulting, so there is no need to change this selection.

If Hold Last State is set to NO for any output on a block, and total bus scan time will exceed 100mS, you should change this selection to 10 seconds.

Hand-held Monitor Configuration Steps

```

OUTPUT DEF.TIME
REF
TIME = 2.5 SECS
tgl entr nxt

```

1. To change the configuration, press F2 (tgl).
2. To save the new selection, press F3 (entr).
3. Press F4 (next) to advance to the next configuration display.

CPU Redundancy

These blocks can be configured for No CPU Redundancy, Hot Standby or Duplex redundancy. For new blocks, it is set to No Redundancy. It must be changed only if the block should be able to receive output data from two CPUs.

In Hot Standby mode, a block receives output data from both CPUs but uses the data from only one of them to drive its outputs. The block prefers outputs sent by the bus controller with Device Number 31. If those outputs are not available, the block uses outputs from the bus controller with Device Number 30. If no outputs from a CPU are available, outputs either Hold Last State or default (as configured).

In Duplex redundancy mode, a block compares outputs received from two CPUs and sets any outputs for which there is disagreement to their Duplex Default state.

Hand-held Monitor Configuration Steps

```

CPU REDUNDANCY
REF
NO CTRL REDUND
tgl entr nxt

```

1. To change the current selection, press F2 (tgl).
2. Press F3 (entr) to save the new selection.
3. Press F4 (next) to advance to the next configuration display.

Duplex Default State

In Duplex Redundancy mode, if the block receives different output states for given points from the two CPUs, the block breaks the tie by outputting the Duplex Default State to those points. For new blocks, OFF is selected for all outputs. Change it if outputs should be ON.

Hand-held Monitor Configuration Steps

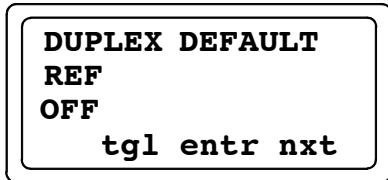

1. To change the Duplex Default state, press F2 (tgl).
2. Press F3 (entr) to save the new selection.
3. Press F4 (nxt) to advance to the next configuration display.

Note

If the block loses communications with BOTH CPUs, individual outputs go to their configured Hold Last State or Output Default State.

Configuration Protection

After the block is configured, its Configuration Protection should be enabled to prevent unwanted changes (from a Hand-held Monitor and from the CPU). Configuration Protection can only be set and removed by a Hand-held Monitor. For a new block, Configuration Protection is disabled.

Hand-held Monitor Configuration Steps

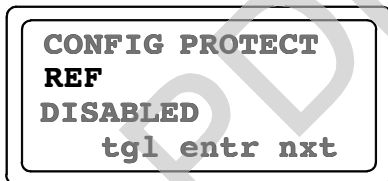

1. To change the current selection, press F2 (tgl).
2. Press F3 (entr) to save the new selection.
3. Press F4 (nxt) to return to the first configuration display.