

IC610MDL101

New In Stock!

GE Fanuc

<http://www.pdfsupply.com/automation/ge-fanuc/ge-series-one-1/IC610MDL101>

Ge Series One 1

1-919-535-3180

**In Stock! GE 24Vdc Sink Input (8points) IC610M IC610MD
IC610MDL**

www.pdfsupply.com

Email: sales@pdfsupply.com

**24 V dc Sink Input (8 Circuits)
IC610MDL101**

This module provides 8 circuits each designed to receive a single discrete (ON/OFF) signal from user supplied devices. Typical input devices include limit switches, pushbuttons, selector switches, and relay contacts. Power (24 V dc) to sense the state of these inputs is provided by the rack power supply. No external power source is required with this module. All 8 circuits are powered from this one source. Figure 6-8 provides wiring information for this module. Following are specifications for each of the 8 circuits:

Input Points	8
Maximum Voltage (Open Circuit)	36 V dc
Input Current	18 mA
Input Impedance	1.8 K ohms
ON Level*	< 3 V dc
OFF Level*	> 3 V dc
OFF to ON Response	4 to 15 ms
ON to OFF Response	4 to 15 ms
Circuit Indicator	Field Side
Maximum OFF Leakage	3 mA
Minimum ON Current	7 mA
Internal Power Consumption	14 mA for each ON Circuit @ 24 V dc 10 mA @ 9 V dc
Units of Load	1 @ 9 V dc 10 @ 24 V dc
Weight	4.2 oz (120 g)

* Voltage levels measured between common and input terminals (across input device).

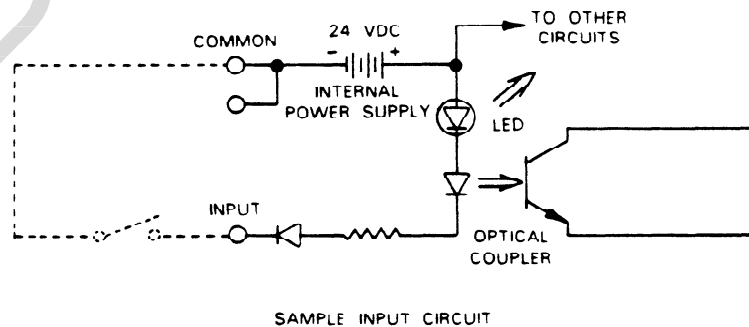
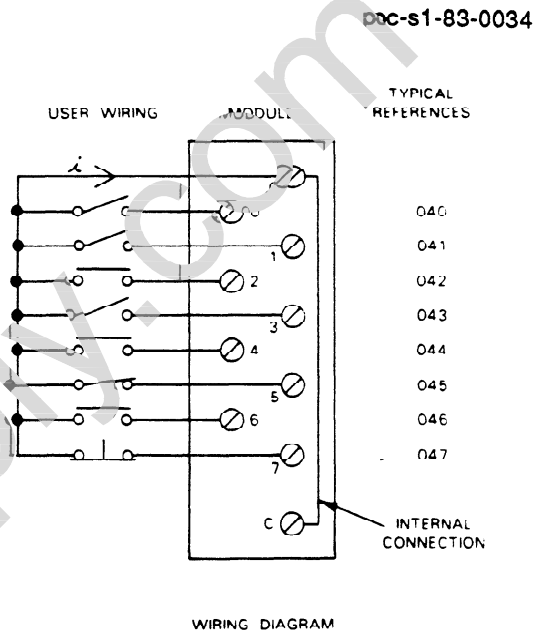

Figure 6-8. Wiring for 24 V ac Sink Inputs