

**IC600YR511**  
**New In Stock!**  
**GE Fanuc**

<http://www.pdfsupply.com/automation/ge-fanuc/ge-series-six-6/IC600YR511>

**Ge Series Six 6**  
**1-919-535-3180**

In Stock! 19 inch I/O Rack Older Version IC600Y IC600YR

[www.pdfsupply.com](http://www.pdfsupply.com)

Email: [sales@pdfsupply.com](mailto:sales@pdfsupply.com)

GEK-83516D

4. Any combination of Input, Output, I/O Transmitter and/or Remote I/O Driver modules can be installed in the other ten card slots in the rack, after the DIP switches (Figure 4) for each have been set to the appropriate address as indicated in Table 2. Note that an optional wiring trough is available to facilitate field-wiring to the various modules.

NOTE

If the POWER LED does not light at power-up, or intermittent errors occur in the course of operation, the current-rating of the I/O rack could be exceeded. Refer to Table 3, I/O Current Units to determine the total current requirements within a rack.

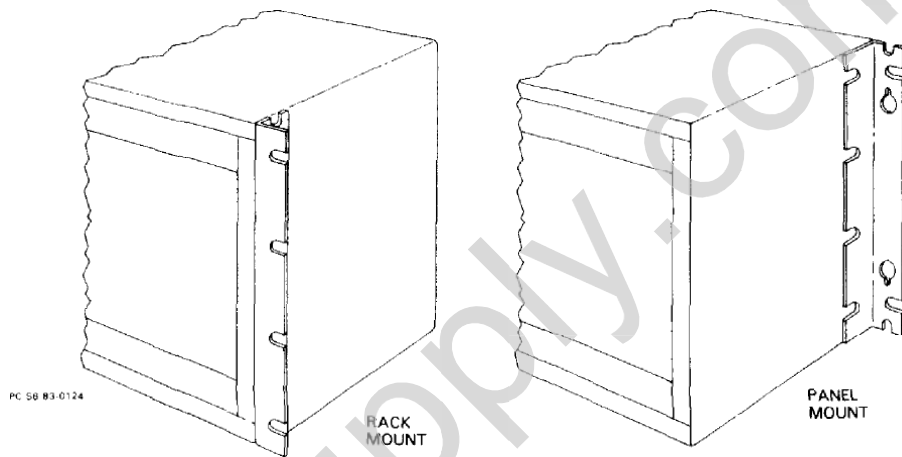

Figure 2, Use of Mounting Brackets

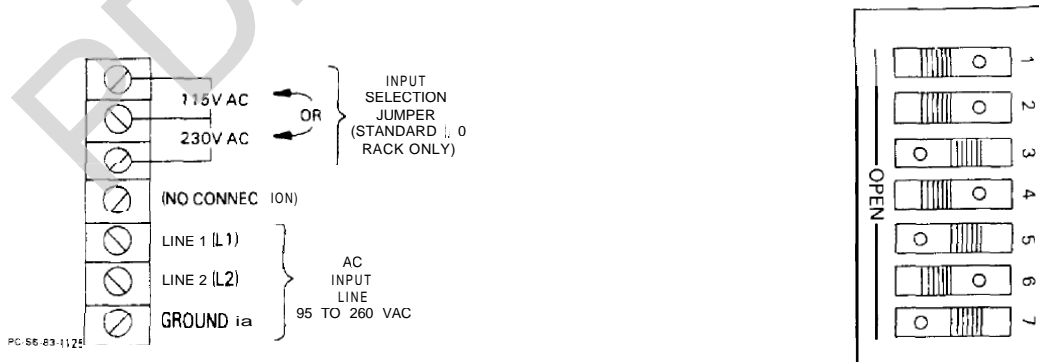

Figure 3. I/O Rack Front-Panel Terminal Block

Figure 4. Dip Switch

Table 2. Dip Switch Settings for I/O Point Selection for Eight-Circuit Modules

I/O Point	Dip Switch Position						
	7	6	5	4	3	2	1
1- 8							
9- 16							X
17- 24						X	
25- 32						X	X
33- 40					X		
41- 48					X		X
49- 56					X	X	
57- 64					X	X	X
65- 72				X			
73- 80				X			X
81- 88				X		X	
89- 96				X		X	X
97-104				X	X		
105-112				X	X		X
113-120				X	X	X	
121-128				X	X	X	X
129-136		X					
137-144		X					X
145-152		X				X	
153-160		X				X	X
161-168		X		X			
169-176		X		X			X
177-184		X		X	X		
185-192		X		X	X	X	
193-200		X	X				
201-208		X	X				X
209-216		X	X			X	
217-224		X	X			X	X
225-232		X	X	X			
233-240		X	X	X			X
241-248		X	X	X	X		
249-256		X	X	X	X	X	X
257-264		X					
265-272		X					X
273-280		X				X	
281-288		X				X	X
289-296		X			X		
297-304		X			X		X
305-312		X			X	X	
313-320		X			X	X	X
321-328		X		X			
329-336		X		X			X

I/O Point	Dip Switch Position						
	7	6	5	4	3	2	1
337-344		X		X		X	
345-352		X		X		X	X
353-360		X		X	X		
361-368		X		X	X		X
369-376		X		X	X	X	
377-384		X		X	X	X	X
385-392		X	X				
393-400		X	X				X
401-408		X	X			X	
409-416		X	X			X	X
417-424		X	X		X		
425-432		X	X		X		X
433-440		X	X		X	X	
441-448		X	X		X	X	X
449-456		X	X	X			
457-464		X	X	X			X
465-472		X	X	X		X	
473-480		X	X	X		X	X
481-488		X	X	X	X		
489-496		X	X	X	X		X
497-504		X	X	X	X	X	
505-512		X	X	X	X	X	X
513-520	X						
521-528	X						X
529-536	X					X	
537-544	X					X	X
545-552	X				X		
553-560	X				X		X
561-568	X				X	X	
569-576	X				X	X	X
577-584	X			X			
585-592	X			X			X
593-600	X			X		X	
601-608	X			X		X	X
609-616	X			X	X		
617-624	X			X	X		X
625-632	X			X	X	X	
633-640	X			X	X	X	X
641-648	X		X				
649-656	X		X				X
657-664	X		X			X	
665-672	X		X			X	X

I/O Point	Dip Switch Position						
	7	6	5	4	3	2	1
673-680	X		X		X		
681-688	X		X		X		X
689-696	X		X		X	X	
697-704	X		X		X	X	X
705-712	X		X	X			
713-720	X		X	X			X
721-728	X		X	X			X
729-736	X		X	X		X	X
737-744	X		X	X	X		
745-752	X		X	X	X		X
753-760	X		X	X	X	X	
761-768	X		X	X	X	X	X
769-776	X	X					
777-784	X	X					X
785-792	X	X					X
793-800	X	X				X	X
801-808	X	X			X		
809-816	X	X			X		X
817-824	X	X			X	X	
825-832	X	X			X	X	X
833-840	X	X		X			
841-848	X	X		X			X
849-856	X	X		X		X	
857-864	X	X		X		X	X
865-872	X	X		X	X		
873-880	X	X		X	X		X
881-888	X	X		X	X	X	
889-896	X	X		X	X	X	X
897-904	X	X	X				
905-912	X	X	X				X
913-920	X	X	X				X
921-928	X	X	X			X	X
929-936	X	X	X			X	
937-944	X	X	X			X	X
945-952	X	X	X			X	X
953-960	X	X	X			X	X
961-968	X	X	X	X			
969-976	X	X	X	X			X
977-984	X	X	X	X			X
985-992	X	X	X	X			X
993-1000	X	X	X	X	X		

[X] = Switch in OPEN Position (Depressed to the Left).

GEK-835 16D

Table 3. Summary of Units of Load for I/O Modules

Catalog Number	Module Description	Units of Load (1)		
		+5 v	+12 v	-12 v
IC600BF800	I/O Receiver	9		s
IC600BF801	Remote I/O Receiver	42	10	10(2)
IC600BF802	24 to 48 V dc Input	2		
IC600BF804	115 V ac/dc Input	2	*	
IC600BF805	230 V ac/dc Input	2		
IC600BF806	12 V ac/dc Input	2		
IC600BF808	Interrupt Input	3		
IC600BF810	115 V ac/dc Isolated Input	2		1
IC600BF813	Type J Thermocouple Input	29	*	.
IC600BF814	Type K+ Thermocouple Input	29		
IC600BF815	Type S Thermocouple Input	29		
EC600BF816	Type T Thermocouple Input	29		.
IC600BF817	Type B Thermocouple Input	29		.
IC600BF818	Type E Thermocouple Input	29		
IC600BF819	Type R Thermocouple Input	29		
IC600BF827	High Speed Counter	19	.	
IC600BF830	Advanced I/O Receiver	12		
IC600BF831	High Density Input	4		
IC600BF841	0 to 10 V dc Analog Input	29	.	
IC600BF842	10 V dc Analog Input	29	.	
IC600BF843	4 to 20 mA Analog Input	29	.	.
IC600BF900	I/O Transmitter	34		
IC600BF901	Remote I/O Driver	38	10	10(2)
IC600BF902	24 V dc Sink Output	7	b	
IC600BF903	48 V dc Sink Output	7	.	
IC600BF904	115 V ac Output	9		
IC600BF905	230 V ac Output	9		
IC600BF906	12 V dc Sink Output	7		
IC600BF907	12 V dc Source Output	7	.	
IC600BF908	24 V dc Source Output	7		
IC600BF909	48 V dc Source Output	7		
IC600BF910	115 V ac Isolated Output	8	.	
IC600BF912	230 V ac Isolated Output	8		
IC600BF914	Reed relay output	13		
IC600BF915	Axis Positioning Module, Type 1	23	7	3
IC600BF917	Axis Positioning Module, Type 2	21	11	6
IC600BF921	5 v TTL output	3	.	
IC600BF923	10 to 50 V dc Sink Output	3		
IC600BF924	120 V dc Output	5		
IC600BF929	10 to 50 V dc Source output	3		
IC600BF930	115 V ac Protected Output	8	.	
IC600BF941	0 to 10 V dc Analog Output	29		

Table 3. Summary of Units of Load for I/O Modules - Continued

Catalog Number	Module Description	Units of Load (1)		
		+5 v	+12 v	-12 v
IC600BF942	10 V dc Analog Output	29	-	-
IC600BF943	4 to 20 mA Analog Output	29	-	-
IC600BF944	ASCII/BASIC Module (12K)	20	12	-
IC600BF949	ASCII/BASIC Module (28K)	20	12	-
IC600BF946	Loop Management Module	20	12	-
IC600BF947	I/O Link Local	20	12	-
IC600BF948	I/O CCM	20	12	-
IC600BF950	I/O CCM4	20	12	-
IC660CB900	Genius Bus Controller	20	2	-
IC660CB902	Genius Bus Controller w/Diag.	20	2	-
IC660CB901	Genius Bus Controller	20	2	-
IC660CB903	Genius Bus Controll wo/Diag.	20	2	-

(1) For +5 V dc, 1 unit of load equals 60 mA (300 mw of power). For +12 and -12 V dc, 1 unit of load equals 25 mA (300 mw of power).

(2) +12 V and -12 V current is less than 1 unit of load if RS-232 mode is not used.

GEK-83516D

**Table 4, Specifications**

<ul style="list-style-type: none"> <li>- <b>Dimensions:</b></li> <li>- <b>Weight (Empty):</b></li> <li>- <b>Power Supply Input @ 47Hz-63Hz:</b></li> <li>- <b>Noise Immunity:</b></li> <li>- <b>Power Supply Output:</b></li> <li>- <b>Allowable Power Interruptions:</b></li> <li>- <b>Module Capacity:</b></li> <li>- <b>Operating Temperature:</b></li> <li>- <b>Storage Temperature:</b></li> <li>- <b>Humidity:</b></li> </ul>	<p>Rack-Mount: 19.0 x 14.0 x 10.3 (inches) 483 x 356 x 261 (mm)</p> <p>Panel-Mount: 20.0 x 14.0 x 10.3 (inches) 508 x 356 x 261 (mm)</p> <p>30 pounds (15Kg)</p> <p>High Capacity: 95 to 260 <b>Vac, 250 VA</b> (max.)</p> <p>Standard: 95-130 Vac 190-260 Vac 80 VA (maximum)</p> <p>Meets requirements of NEMA ICS 2-230 and ANSI C37,90A.</p> <p>High Capacity: +5 Vdc, 16.5 A max      Total power                          +12 Vdc, 1.5 A max.      is limited to                          -12 Vdc, 1.0 A max.      3 90 watts.</p> <p>Standard: +5 Vdc, 6.1 A max.</p> <p>33 ms minimum at 115 Vac line.</p> <p>Ten Addressable card slots, plus one non-addressable slot for an I/O Receiver module.</p> <p>0 -60° C (outside of the rack)</p> <p>-20C - +80C</p> <p>5%-95 % (non-condensing)</p>
---	--

**Table 5. Ordering Information**

Standard I/O Rack	High-Capacity I/O Rack
IC600YR50 1B	IC600YR511A

**Catalog Number Revision Suffix**

The equipment listed above having the catalog numbers shown and the same equipment having a higher alpha suffix is designed for listing by UL for use as auxiliary control devices. The equipment is a direct replacement for equipment having the same catalog number but a lower alpha suffix.

The UL symbol on the nameplate means the product is listed by Underwriters Laboratories Inc. (UL Standard No. 508, Industrial Control Equipment, subsection Electronic Power Conversion Equipment.)

For further information, contact your local GE Fanuc sales office.