

GFK-2069
New In Stock!
GE Fanuc Manuals

[http://www.pdfsupply.com/automation/ge-fanuc-manuals/operator-
interface/GFK-2069](http://www.pdfsupply.com/automation/ge-fanuc-manuals/operator-interface/GFK-2069)

operator-interface
1-919-535-3180

7.4 QuickPanel Installation

www.pdfsupply.com

Email: sales@pdfsupply.com

GFK-2069
New In Stock!
~~GE Fanuc Manuals~~

<http://www.pdfsupply.com/automation/ge-fanuc-manuals/operator-interface/GFK-2069>

operator-interface
1-919-535-3180

7.4 QuickPanel Installation

www.pdfsupply.com

Email: sales@pdfsupply.com

7.4" QUICKPANEL

(QPGCxDE0000)

Installation Guide

The following are trademarks of Total Control Products, Inc.: *QUICKPANEL*[™] and *QUICKPANEL jr.*[™]

Information in this document is subject to change without notice and does not represent a commitment on the part of Total Control Products, Inc. The software described in this document is provided under a license agreement. The software may be used or copied only under the terms of the agreement. Only one copy of the software may be made for a backup.

Total Control Products, Inc. makes no warranty, either expressed or implied, including but not limited to any implied warranties of merchantability or fitness for a particular purpose, regarding these materials and makes such materials available solely on an "as-is" basis.

In no event shall Total Control Products, Inc. be liable to anyone for special, collateral, incidental, or consequential damages in connection with or arising out of purchase or use of these materials. The sole and exclusive liability to Total Control Products, Inc., regardless of the form of action, shall not exceed the purchase price of the materials described herein.

No part of this manual may be reproduced or transmitted in any form or by any means, electronic or mechanical, including photocopying, recording, or information storage and retrieval systems, for any purpose other than the purchaser's personal use, without the express written permission of Total Control Products, Inc.

Copyright 1995, Total Control Products, Inc. All rights reserved.

Total Control Products, Inc.
2700 Oxford Tower, 10235-101 Street, Edmonton, Alberta T5J 3G1, CANADA
Phone (780) 420-2000, Fax (780) 420-2049

Essential Safety Precautions

WARNINGS

System Design

- Please design your system so that equipment will not malfunction due to a communication fault between the QP and its host controller. This is to prevent any possibility of bodily injury or material damage.
- The QP is not appropriate for use with aircraft control devices, aerospace equipment, central trunk data transmission (communication) devices, nuclear power control devices, or medical life support equipment, due to these devices' inherent requirements of extremely high levels of safety and reliability.
- When using the QP with transportation vehicles (trains, cars and ships), disaster and crime prevention devices, various types of safety equipment, non-life support related medical devices, etc. redundant and/or failsafe system designs should be used to ensure the proper degree of reliability and safety.
- Do not use the QP unit as a warning device for critical alarms that can cause serious operator injury, machine damage or production stoppage. Critical alarm indicators and their control/activator units must be designed using stand-alone hardware and/or mechanical interlocks.
- After the QP's backlight burns out, unlike the QP's "Standby Mode", the touch panel is still active. If the operator fails to notice that the backlight is burned out and touches the panel, a potentially dangerous machine miss-operation can occur. Therefore, do not use QP touch switches for the control of any equipment safety mechanisms, such as Emergency Stop switches, etc. that protect humans and equipment from injury and damage. If your QP's backlight suddenly turns OFF, use the following steps to determine if the backlight is actually burned out.
 - 1) If your QP is not set to "Standby Mode" and the screen has gone blank, your backlight is burned out.
 - 2) Or, if your QP is set to Standby Mode, but touching the screen does not cause the display to reappear, your backlight is burned out.Also, to prevent accidental machine miss-operation, Digital suggests you use the QP's built-in "USE TOUCH PANEL AFTER BACKLIGHT BURNOUT" feature, that will automatically detect a burnout and disable the touch screen.

Installation

- High voltage runs through the QP. Except for replacing the backlight, never disassemble the QP, otherwise an electric shock can occur.
- Do not modify the QP unit. Doing so may cause a fire or an electric shock.
- Do not use the QP in an environment where flammable gasses are present, since operating the QP may cause an explosion.

Wiring

- To prevent an electric shock, be sure to confirm that the QP's power cord is not connected to the main power when connecting any cords, cables or lines to the QP.
- Do not use power beyond the QP's specified voltage range. Doing so may cause a fire or an electric shock.

Maintenance

- The QP uses a lithium battery for backing up its internal clock data. If the battery is incorrectly replaced, the battery may explode. To prevent this, please do not replace the battery yourself. When the battery needs to be replaced, please contact your local QP distributor.



CAUTIONS

Installation

- Be sure to securely connect all cable connectors to the QP. A loose connection may cause incorrect input or output.

Wiring

- Ground the QP's FG line separately from other units' FG lines. Putting these FG lines too close may cause an electric shock or unit malfunction. Be sure to use a grounding resistance of 100Ω or less and a 2mm² or thicker wire, or your country's applicable standard.
- Correctly wire the QP, be sure that the rated voltage and terminal layout are within the designated wire range. If the voltage supplied differs from the rated voltage, or incorrect wiring or grounding is performed, it may cause a fire or unit malfunction.
- Use only the designated torque to tighten the QP's terminal block screws. If these screws are not tightened firmly, it may cause a short-circuit, fire, or QP malfunction.
- Be careful that metal filings and wiring debris do not fall inside the QP, since they can cause a fire, QP malfunction, or incorrect operation.

Maintenance

- The liquid crystal panel contains a powerful irritant and if for any reason the panel is damaged and this liquid contacts any part of your body, be sure to wash that area with running water for 15 minutes. If any of this liquid enters your eye, flush your eye for 15 minutes with running water and contact a physician.
- Prior to inserting or removing a CF Card, be sure to turn the QP's CF Card ACCESS switch OFF and to confirm that the ACCESS lamp is not lit. If you do not, CF Card internal data may be damaged or lost.
- While a CF Card is being accessed, NEVER turn OFF or reset the QP, or insert or remove the CF Card. Prior to performing these operations, create and use a special QP application screen that will prevent access to the CF Card.

Unit Disposal

- When this unit is disposed of, it should be done so according to your country's regulations for similar types of industrial waste.

General Safety Precautions

- Do not strike the touch panel with a hard or pointed object, or press on the touch panel with too much force, since it may damage the touch panel or the display.
- Do not install the QP where the ambient temperature can exceed the allowed range. Doing so may cause the QP to malfunction or shorten its operation life.
- Do not restrict or limit the QP's naturally occurring rear-face ventilation, or store or use the QP in an environment that is too hot.
- Do not use this unit in areas where large, sudden temperature changes can occur. These changes can cause condensation to form inside the unit, possibly causing the unit to malfunction.
- Do not allow water, liquids, metal or charged particles to enter inside the QP's case, since they can cause either a QP malfunction or an electrical shock.
- Do not use or store the QP in direct sunlight, or in excessively dusty or dirty environments.
- Do not store or use the unit where strong jolting or excessive vibration can occur.
- Do not store or use the QP where chemicals (such as organic solvents, etc.) and acids can evaporate, or where chemicals and acids are present in the air.
Corrosive chemicals: Acids, alkalines, liquids containing salt
Flammable chemicals: Organic Solvents
- Do not use paint thinner or organic solvents to clean the QP.
- Do not store or operate the LCD display in areas receiving direct sunlight, since the sun's UV rays may cause the LCD display's quality to deteriorate.
- Storing this unit in areas at a temperature lower than is recommended in this manual's specifications may cause the LCD display's liquid to congeal, which may damage the panel. Conversely, if the storage area's temperature becomes higher than the allowed level, the LCD's liquid will become isotropic, causing irreversible damage to the LCD. Therefore, be sure to store the panel only in areas where temperatures are within those specified in this manual.
- After turning the QP OFF, be sure to wait a few seconds before turning it ON again. If the QP is started too soon, it may not start up correctly.
- Due to the possibility of unexpected accidents, be sure to back up the QP's screen data regularly.

UL/c-UL(CSA) Approval

The QPGCxDE0000 are UL/c-UL listed products. (UL file No. E182139)

This Unit conforms as a component to the following standards:

■ **UL508**

Industrial Control Equipment

■ **UL1604**

Electrical Equipment for Use in Class I and II Division 2 and Class III Hazardous (Classified) Locations

■ **CAN/CSA-C22.2, Nos.142,and 213-M1987**

Standard for Safety of Information Technology Equipment, including Electrical Business Equipment

QPGCxDE0000 (UL Registration Model : 2880061)

<Cautions>

- The QP must be used as a built-in component of an end-use product.
- The QP should be installed in the front face of a metal panel.
- If the QP is installed so as to cool itself naturally, be sure to install it in a vertical panel. Also, be sure that the QP is mounted at least 100mm away from adjacent structures and other equipment, otherwise, the heat generated by the QP's internal components may become higher than that allowed by UL standard requirements.

UL1604 Conditions of Acceptability and Handling Cautions:

1. Power, input and output (I/O) wiring must all be in accordance with Class I, Division 2 wiring methods, Article 501-4 (b) of the National Electrical Code, NFPA 70, or as specified in Section 18-152 of the Canadian Electrical Code for units installed within Canada, and in accordance with that location's authority.
2. Suitable for use in Class I, Division2, GroupsA, B, C and D hazardous location, or nonhazardous locations only.
3. **WARNING:** Explosion hazard - substitution of components may impair suitability for Class I, Division2.
4. **WARNING:** Explosion hazard - do not disconnect equipment unless power has been switched off or the area is known to be nonhazardous.
5. **WARNING:** Explosion hazard - when in hazardous locations, turn off power before replacing or wiring modules.

CE Marking

QPGCxDE0000 are CE marked , EMC compliant products. These units also conform to EN55011 ClassA , EN50082-2 directives.

For detailed CE marking information, please contact your local distributor.

Package Contents

The following items are included in the QP's package. Before using the QP, please confirm that all items listed here are present.

- **QP Unit (1)**
(QPGCxDE0000)

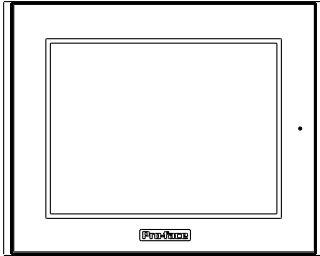

- **QuickPanel Installation Guide (1)**
<This Guide>

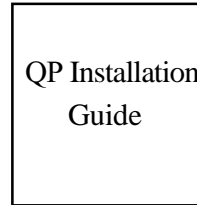

- **Installation Fasteners (4)**

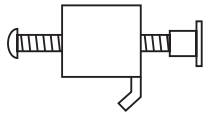

- **Installation Gasket (1)**



This unit has been carefully packed, with special attention to quality. However, should you find anything damaged or missing, please contact your local QP distributor immediately.

Options

- **QuickPanel Hardware Reference Guide**

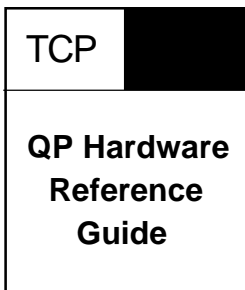

- **Cables**
- **Software**
- **Maintenance Parts**

(For details about available options, refer to the QuickPanel Ordering Guide.)

1 Part Names

A : Display

B : Touch Panel

C : Status LED

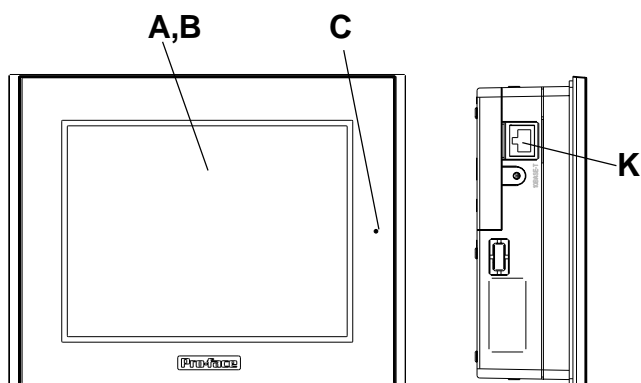

LED	QP Status
Not Lit	Power is OFF.
Green	Normal operation
Orange	Backlight is not functioning. (Refer to 10.Changing the Backlight.)

D : Power Input Terminal Block

E : Expansion Unit Connector

F : CF Card Access Lamp

G : CF Card Slot

H : Serial Connector (HOST-I/F 25-pin)

I : Serial Connector (SUB-SIO 9-pin)

J : Printer Connectorb (Half Pitch 20-pin)

K : Ethernet Interface (10BASE-T)

L : Sound and AUX Connector

M : Tool Connector

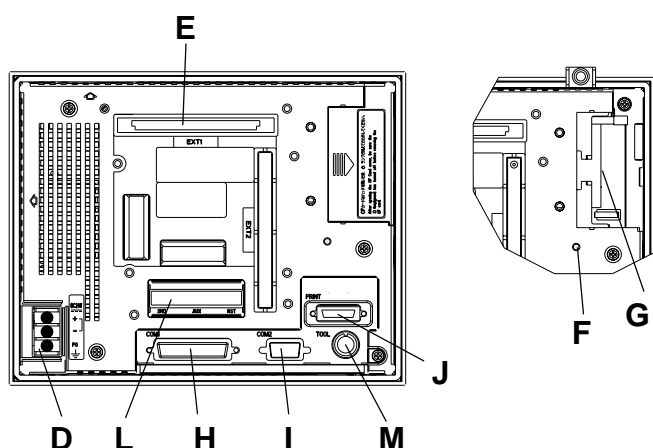

2 Dimensions

Unit:mm [in.]

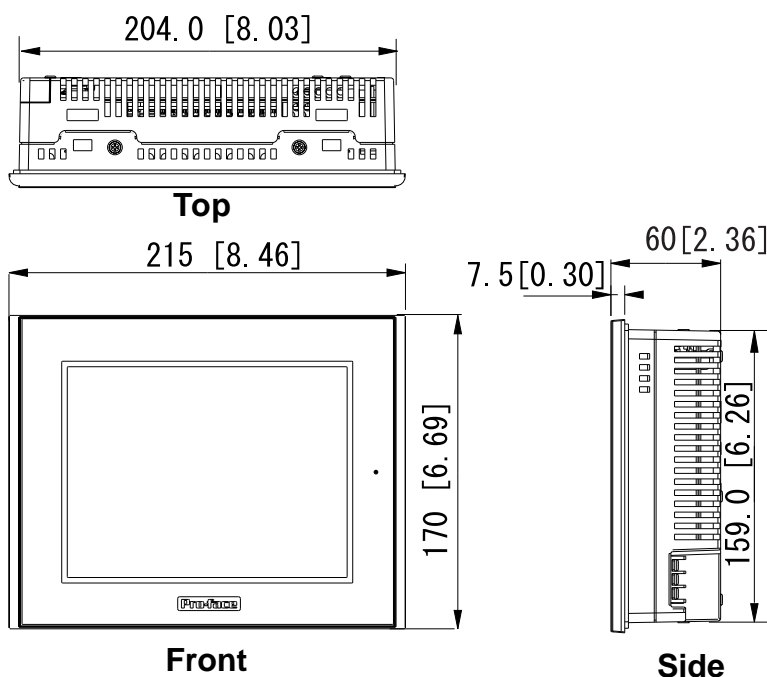

3 Dip Switches

These switches are located inside the CF Card's cover.

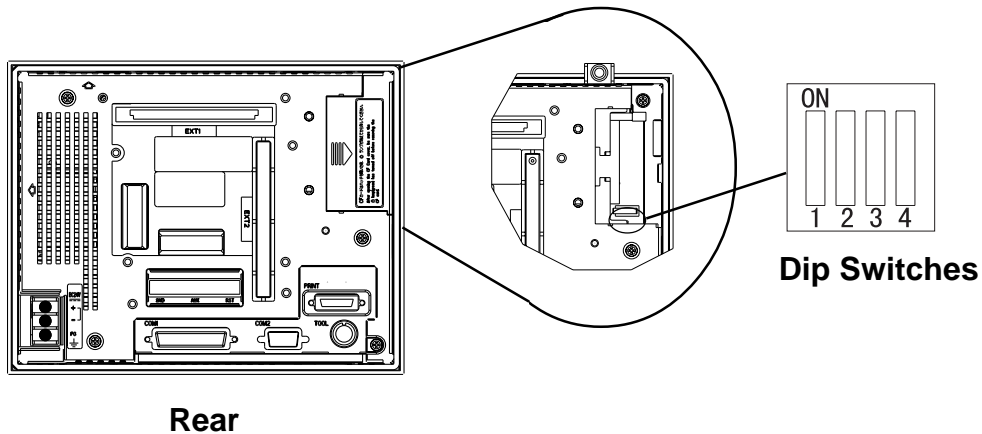

Dip Switch	Function	ON	OFF	Note
1	This Dip switch setting controls the startup from a CF Card.	Startup from CF Card is enabled.	Startup from CF Card is disabled.	CF Card with startup data required.
2	Reserved	—	—	—
3	Reserved	—	—	—
4	This setting controls the forced closing of the CF Card cover.	Forced close enabled.	Forced close disabled.	Used when CF Card cover is damaged.

4 Interfaces

■ Serial Interface (HOST-I/F)

This interface is used to connect the QP to the host (PLC), via an RS-232C or RS-422 cable.

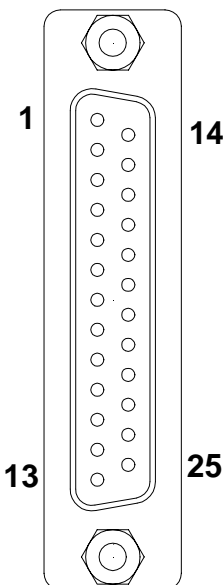
Pin Arrangement	Pin #	Signal Name	Condition
	1	FG	Frame Ground
	2	SD	Send Data (RS-232C)
	3	RD	Receive Data (RS-232C)
	4	RS	Request to Send (RS-232C)
	5	CS	Clear to Send (RS-232C)
	6	DR	Data Set Ready (RS-232C)
	7	SG	Signal Ground
	8	CD	Carrier Detect (RS-232C)
	9	TRMX	Termination (RS-422)
	10	RDA	Receive Data A (RS-422)
	11	SDA	Send Data A (RS-422)
	12	NC	No Connection(Reserved)
	13	NC	No Connection(Reserved)
	14	VCC	5V±5% Output 0.25A
	15	SDB	Send Data B (RS-422)
	16	RDB	Receive Data B (RS-422)
	17	RI	Ring Indicate (RS-232C)
	18	CSB	Clear to Send B (RS-422)
	19	ERB	Enable Receive B (RS-422)
	20	ER	Enable Receive (RS-232C)
	21	CSA	Clear to Send A (RS-422)
	22	ERA	Enable Receive A (RS-422)
	23	NC	No Connection(Reserved)
	24	NC	No Connection(Reserved)
	25	NC	No Connection(Reserved)

Recommended Connector : Dsub 25 pin plug XM2A-2501
<made by OMRON Corp.>

Recommended Cover : Dsub 25 pin Cover XM2S-2511
<made by OMRON Corp.>

Recommended Screw : Jack Screw XM2Z-0071 <made by OMRON Corp.>

Recommended Cable : CO-MA-VV-SB5P x 28AWG
<made by HITACHI Cable Ltd.>



- **Since Pin#14(VCC) is unprotected, be sure to keep the output current within the rated range.**
- **Be sure to connect the QP's Pin#7 (SG) terminal to the other (host) unit's Signal Ground terminal.**



Use rough metric type M2.6 x 0.45p threads to hold the cable's set (fastening) screws in place.

When creating a cable, please be aware of the following:

<For RS-422 Connectors>

- The following pairs of pin numbers must be connected (shorted).
 - ...#18 (CSB) <-> #19 (ERB)
 - ...#21 (CSA) <-> #22 (ERA)
- Connecting the #9 (TRMX) and #10 (RDA) wires, adds a termination resistance of 100W between RDA and RDB.
- Use a 4-wire cable when the PLC type is Memory Link and the cable is RS-422.

<For RS-232C Connectors>

- Do not connect #9 (TRMX), #10 (RDA), #11 (SDA), #15 (SDB), #16 (RDB), #18 (CSB), #19 (ERB), #21 (CSA), and #22 (ERA).

■ Serial Interface (SUB-SIO) — *Not Supported (contact factory)*

Pin Arrangement	Pin #	Signal Name	Meaning
	1	CD	Carrier Detect(RS-232C)
	2	RD	Receive Data(RS-232C)
	3	SD	Send Data(RS-232C)
	4	ER	Enable Receive(RS-232C)
	5	SG	Signal Ground
	6	DR	Data Set Ready(RS-232C)
	7	RS	Request to Send(RS-232C)
	8	CS	Clear to Send(RS-232C)
	9	RI/VCC	Ring Indicate(RS-232C) 5V±5% 0.25A

Recommended Connector : Dsub 9 pin plug XM2D-0901 <made by OMRON Corp.>

Recommended Cover : Dsub 9 pin cover XM2S-0913 <made by OMRON Corp.>

Recommended Screw : Jack Screw XM2Z-0073 <made by OMRON Corp.>



Since Pin#9(RI/VCC) is unprotected, be sure to keep the output current within the rated range.

■ Printer Interface (Half Pitch 20-pin)

Pin Arrangement	Pin #	Signal Name	Meaning
	1	GND	Ground
	2	RESERVE	Reserved
	3	PDB5	Data Signal
	4	PDB4	Data Signal
	5	PDB3	Data Signal
	6	GND	Ground
	7	SLCT	Select Condition(Input)
	8	PDB0	Data Signal
	9	PSTB	Strobe Signal(Output)
	10	BUSY	Busy Signal(Input)
	11	PDB7	Data Signal
	12	PDB6	Data Signal
	13	GND	Ground
	14	ERROR	Printer Error(Input)
	15	GND	Ground
	16	PDB2	Data Signal
	17	PDB1	Data Signal
	18	PE	Paper End
	19	INIT	Initialize Signal(Output)
	20	GND	Ground

■ Screw Lock Terminal Block (12 pin) — *Not Supported (contact factory)*

This interface performs external reset, AUX and sound output.

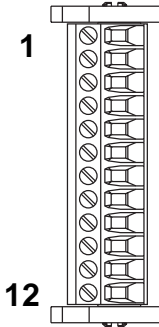
Pin Arrangement	I/F	Pin No.	Signal Name	Meaning
	External Reset	1	AUXCOM	External Reset Common
		2	AUXRESET	External Reset Input
	AUX	3	RUN	Online
		4	ALARM	Error Occurred
		5	OUTCP	24VDC
		6	BUZZ	External Buzzer Output
		7	Reserved	Reserved
		8	OUTCN	0V
		9	Reserved	Reserved
	Sound I/F	10	SP OUT	Speaker Output Terminal
		11	GND	Ground
		12	LINE OUT	Line Out Output Terminal

■ Ethernet Interface

This interface complies with the IEEE802.3 standard for Ethernet (10BASE-T) connections. This interface uses an RJ-45 type modular jack connector (8 points).

■ CF Card Interface

This slot accepts a CF Card.

■ Expansion Unit Interface

This interface is used to connect an expansion unit that can transmit data over a Fieldbus or similar type of network.

5 Installation

■ Confirm the Installation Gasket's Positioning

It is strongly recommended that you use the gasket. It absorbs vibration in addition to repelling water.

Place the QP on a level surface with the display panel facing downward. Check that the QP's installation gasket is seated securely into the gasket's groove, which runs around the perimeter of the panel's frame.



- ***Before installing the QP into a cabinet or panel, check that the installation gasket is securely attached to the unit.***
- ***A gasket which has been used for a long period of time may have scratches or dirt on it, and could have lost much of its dust and drip resistance. Be sure to change the gasket periodically (or when scratches or dirt become visible).***

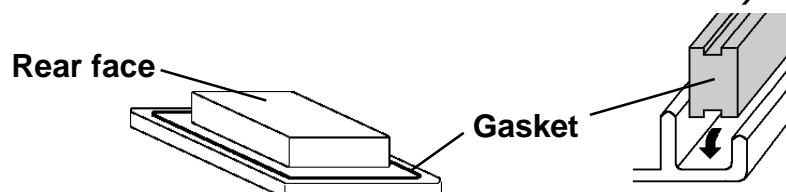

■ Create a Panel Cut and insert the QP into the panel from the front

Unit: mm [in]

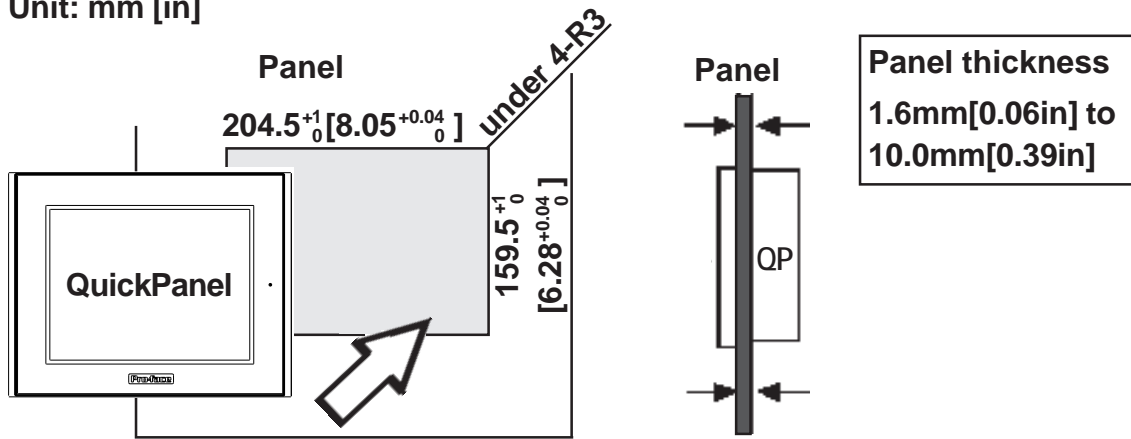

■ Attach the Installation Fasteners from Inside the Panel

The following figures show the four (4) fastener insertion slot locations. Insert each fastener's hook into the slot and tighten it with a screwdriver.

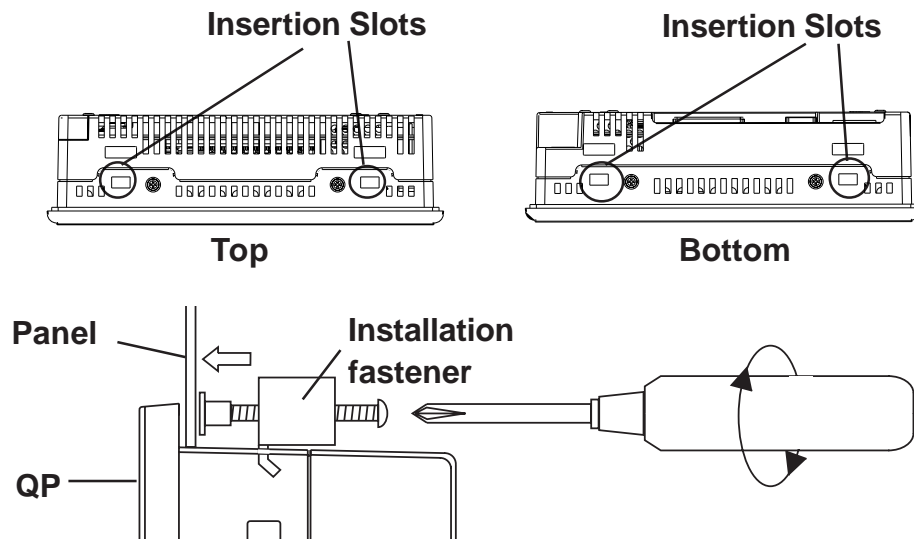

- *Tightening the screws with too much force can damage the QP's plastic case.*
- *The necessary torque is 0.5 N•m.*

6 Wiring



WARNINGS

- **To avoid an electric shock, prior to connecting the QP's power cord terminals to the power terminal block, confirm that the QP's power supply is completely turned OFF, via a breaker, or similar unit.**
- **The QPGCxDE0000 units are designed to use only DC24V input. Any other power level can damage both the QP and the power supply.**
- **Since there is no power switch on the QP unit, be sure to attach a breaker type switch to its power cord.**



When the FG terminal is connected, be sure the wire is grounded. Not grounding the QP unit will result in excess noise and vibration.



- Wherever possible, use thick wires (max. 2 mm²) for power terminals, and twist the wire ends before attaching the ring terminals.
- Be sure to use the following size ring terminals.*¹
- To avoid a short caused by loose ring terminals, be sure to use ring terminals with an insulating sleeve.

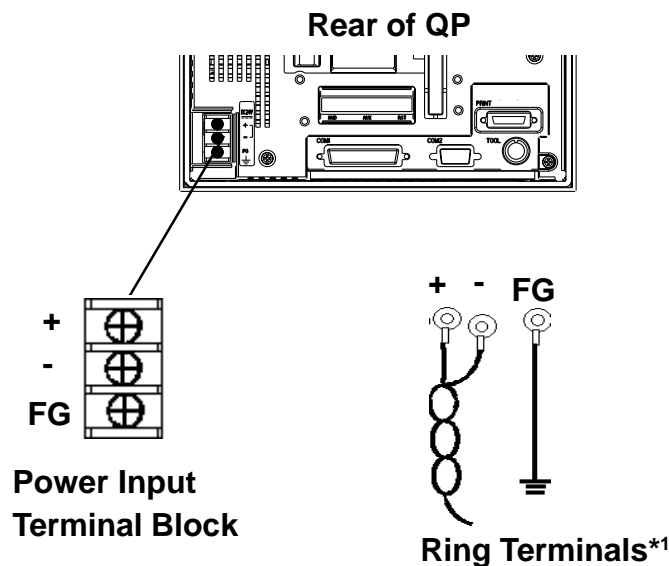
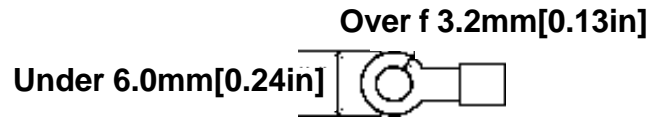

■ Connecting the QP Power Cord

When connecting the power cord, be sure to follow the procedures given below.

1. Confirm that the QP's Power Cord is unplugged from the power supply.
2. Use a screwdriver to remove the Power Input Terminal Block's clear plastic cover.
3. Unscrew the screws from the middle three (3) terminals, align the Ring Terminals and re-attach the screws.
4. Confirm that the wires are connected correctly.
5. Replace the Power Input Terminal Block's clear plastic cover.



The torque required to tighten these screws is 0.5 N•m.

*¹ Suggested Ring Terminal : V2-MS3 (made by JST)

7 Power Supply Cautions

Please pay special attention to the following instructions when connecting the power cord terminals to the QP unit.

- If the power supply voltage exceeds the QP's specified range, connect a voltage transformer.
- Between the line and the ground, be sure to use a low noise power supply. If there is still an excessive amount of noise, connect a noise reducing transformer.
- Input and Output signal lines must be separated from the power control cables for operational circuits.
- To increase the noise resistance, be sure to twist the ends of the power cord wires before connecting it to the QP unit.
- The QP's power supply cord should not be bundled with or kept close to main circuit lines (high voltage, high current), or input/output signal lines.
- Connect a surge absorber to handle power surges.
- To reduce noise, make the power cord as short as possible.

8 Grounding Cautions

- When attaching a wire to the QP's rear face FG terminal, (on the Power Input Terminal Block), be sure to create an exclusive ground.*1
- Inside the QPGCxDE0000 unit, the SG(Signal Ground) and FG(Frame Ground) terminals are connected to each other.
- When attaching an expansion unit to the QP, be sure to read the expansion unit's Installation Guide.

9 Input/Output Signal Line Cautions

- All QP Input and Output signal lines must be separated from all operating circuit (power) cables.
- If this is not possible, use a shielded cable and ground the shield.

10 Replacing the Backlight

The QP unit's backlight is user replaceable.

For an explanation of how to replace the QP's backlight, please refer to the Backlight Replacement Guide included with the replacement backlights (sold separately).

QP Unit	Required Backlight Model
QPGCxDE0000	HMI-CCT-402



Use of a different model backlight may cause a QP malfunction or breakdown.

*1 Use a grounding resistance of 100Ω, a wire of 2mm² or thicker, or your country's applicable standard.