

GFK-2059
New In Stock!
GE Fanuc Manuals

<http://www.pdfsupply.com/automation/ge-fanuc-manuals/series-90-70-9070/>

[GFK-2059](#)
series-90-70-9070
1-919-535-3180

IC697VAL348 Analog Output

www.pdfsupply.com

Email: sales@pdfsupply.com

GFK-2059
New In Stock!
~~GE Fanuc Manuals~~

[http://www.pdfsupply.com/automation/ge-fanuc-manuals/series-90-70-9070/-](http://www.pdfsupply.com/automation/ge-fanuc-manuals/series-90-70-9070/)

[GFK-2059](#)
series-90-70-9070
1-919-535-3180

IC697VAL348 Analog Output

www.pdfsupply.com

Email: sales@pdfsupply.com



GE Fanuc Automation

Programmable Control Products

IC697VAL348 8-Channel, 16-bit Digital-to-Analog Converter Board

User's Manual

GFK-2059

514-000437-000 A

December 2001

Warnings, Cautions, and Notes as Used in this Publication

Warning

Warning notices are used in this publication to emphasize that hazardous voltages, currents, temperatures, or other conditions that could cause personal injury exist in this equipment or may be associated with its use.

In situations where inattention could cause either personal injury or damage to equipment, a Warning notice is used.

Caution

Caution notices are used where equipment might be damaged if care is not taken.

Note

Notes merely call attention to information that is especially significant to understanding and operating the equipment.

This document is based on information available at the time of its publication. While efforts have been made to be accurate, the information contained herein does not purport to cover all details or variations in hardware or software, nor to provide for every possible contingency in connection with installation, operation, or maintenance. Features may be described herein which are not present in all hardware and software systems. GE Fanuc Automation assumes no obligation of notice to holders of this document with respect to changes subsequently made.

GE Fanuc Automation makes no representation or warranty, expressed, implied, or statutory with respect to, and assumes no responsibility for the accuracy, completeness, sufficiency, or usefulness of the information contained herein. No warranties of merchantability or fitness for purpose shall apply.

The following are trademarks of GE Fanuc Automation North America, Inc.

Alarm Master	Genius	PROMACRO	Series Six
CIMPLICITY	Helpmate	PowerMotion	Series Three
CIMPLICITY 90-ADS	Logicmaster	PowerTRAC	VersaMax
CIMSTAR	Modelmaster	Series 90	VersaPro
Field Control	Motion Mate	Series Five	VuMaster
GEnet	ProLoop	Series One	Workmaster

Contents

Chapter 1	Introduction, Description, and Specifications	1-1
	Reference Material and Other GE Fanuc Manuals.....	1-1
	General Description	1-2
	Functional Description	1-3
	Functional Description	1-3
	Safety Summary	1-4
Chapter 2	Configuration and Installation.....	2-1
	Physical Installation	2-2
	Configuration	2-3
	Before Applying Power: Checklist	2-4
	Board Address Selection Switches.....	2-5
	Address Modifier Response Selection	2-7
	Digital Code Selection	2-8
	Program Controlled and External Start Convert Mode	2-9
	Connector Descriptions	2-10
	DAC Zero Offset and Gain Calibration	2-15
Chapter 3	Programming.....	3-1
	Introduction to Programming the Digital-to-Analog Converter Board	3-2
	Digital-to-Analog Converter Board Programming Options	3-3
	Delayed DAC Update Mode	3-6
	Test Mode Programming	3-7
	Program Example (Delayed DAC Update Mode).....	3-8
Chapter 4	Theory of Operation	4-1
	Operational Overview	4-2
	Immediate DAC Update Mode	4-3
	Delayed DAC Update Mode	4-4
	VMEbus Interface Description.....	4-6
Chapter 5	Maintenance.....	5-1

Chapter
1

Introduction, Description, and Specifications

This manual describes installation and operation of the IC697VAL348 8-Channel, 16-Bit Digital-to-Analog Converter (DAC) Board.

Reference Material and Other GE Fanuc Manuals

For a detailed explanation of the VMEbus and its characteristics, “The VMEbus Specification” is available from:

VITA
VMEbus International Trade Association
7825 East Gelding Dr., No. 104
Scottsdale, AZ 85260
(480) 951-8866
FAX: (480) 951-0720
Internet: www.vita.com

The following Application and Configuration Guides are available from GE Fanuc to assist in the selection, specification, and implementation of systems based upon GE Fanuc’s products:

Analog I/O Products (Built-in-Test) Configuration Guide (catalog number GFK-2084)	Provides assistance in configuring analog I/O subsystems based on GE Fanuc’s analog I/O products, including common designs, which offer a wide variety of solutions.
---	--

General Description

The primary features of the Digital-to-Analog Converter Board are as follows:

- 16-Bit resolution
- Buffered voltage output (± 10 V @ 5 mA)
- Double-buffered data latches
- Eight channels
- Eight 16-Bit DACs (one per channel)
- Front panel Fail LED
- High reliability DIN type output connector
- Multiplexed programmable outputs
- Jumper-selectable synchronized update control
- Double Eurocard form factor
- Selectable external update control input provides single update strobe for all DAC outputs
- Fast settling: 10 μ s maximum to ± 0.0003 percent of FSR

Functional Description

The Digital-to-Analog Converter Board delivers ± 10 V outputs with positive true offset binary input coding or two's complement coding. The Digital-to-Analog Converter Board features double-buffered data latches, buffered voltage outputs, and selectable external or internal update control strobes. A front panel Fail LED is provided for quick fault location.

Safety Summary

Warning

The following general safety precautions must be observed during all phases of this operation, service, and repair of this product. Failure to comply with these precautions or with specific warnings elsewhere in this manual violates safety standards of design, manufacture, and intended use of this product. GE Fanuc assumes no liability for the customer's failure to comply with these requirements.

Ground the System

To minimize shock hazard, the chassis and system cabinet must be connected to an electrical ground. A three-conductor AC power cable should be used. The power cable must either be plugged into an approved three-contact electrical outlet or used with a three-contact to two-contact adapter with the grounding wire (green) firmly connected to an electrical ground (safety ground) at the power outlet.

Do Not Operate in an Explosive Atmosphere

Do not operate the system in the presence of flammable gases or fumes. Operation of any electrical system in such an environment constitutes a definite safety hazard.

Keep Away from Live Circuits

Operating personnel must not remove product covers. Component replacement and internal adjustments must be made by qualified maintenance personnel. Do not replace components with power cable connected. Under certain conditions, dangerous voltages may exist even with the power cable removed. To avoid injuries, always disconnect power and discharge circuits before touching them.

Do Not Service or Adjust Alone

Do not attempt internal service or adjustment unless another person, capable of rendering first aid and resuscitation, is present.

Do Not Substitute Parts or Modify System

Because of the danger of introducing additional hazards, do not install substitute parts or perform any unauthorized modification to the product. Return the product to GE Fanuc for service and repair to ensure that safety features are maintained.

Chapter 2

Configuration and Installation

This chapter contains configuration and installation instructions for the Digital-to-Analog Converter Board, and is divided into the following sections:

- Physical Installation
- Configuration
- Before Apply Power: Checklist
- Board Address Selection Switches
- Address Modifier Response Selection
- Digital Code Selection
- Program Controlled and External Start Convert Mode
- Connector Descriptions
- Analog Output Accuracy
- DAC Zero Offset and Gain Calibration

Caution

Some of the components assembled on GE Fanuc's products may be sensitive to electrostatic discharge and damage may occur on boards that are subjected to a high energy electrostatic field. Unused boards should be stored in the same protective boxes in which they were shipped. When the board is to be placed on a bench for configuring, etc., it is suggested that conductive material be inserted under the board to provide a conductive shunt.

Upon receipt, any precautions found in the shipping container should be observed. All items should be carefully unpacked and thoroughly inspected for damage that might have occurred during shipment. The board(s) should be checked for broken components, damaged circuit board(s), heat damage, and other visible contamination. All claims arising from shipping damage should be filed with the carrier and a complete report sent to GE Fanuc together with a request for advice about the disposition of the damaged item(s).

Physical Installation

Caution



Do not install or remove boards while power is applied.

To install the board, de-energize the equipment and insert the board into an appropriate slot of the chassis while ensuring that the board is properly aligned and oriented in the supporting card guides. Slide the board smoothly forward against the mating connector until firmly seated. Review “Configuration” on page 2-3 and “Before Applying Power: Checklist” on page 2-4 before operating the board.

Configuration

This section of the manual describes the Digital-to-Analog Converter Board set-up procedure and jumper configuration. The board select base address and board jumper configuration is factory preset and shown in Table 2-1 below. The base address selection switches (S1 and S2) are factory configured at XXXX0060 HEX.

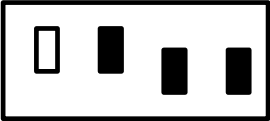
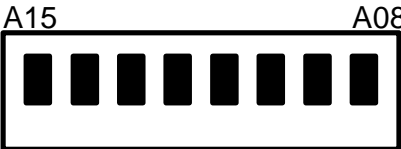
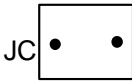
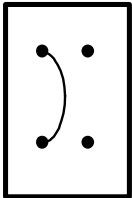
Table 2-1: Digital-to-Analog Converter Board Factory Preset Configuration

Jumper	Function	Preset Condition
S1	Base address selection switches (A07, A06, A05)	<p>NOT USED A07 A06 A05</p>  <p>ON, CLOSED = 0 OFF, OPEN = 1</p>
S2	Base address selection switches (A15 to A08)	 <p>ON OFF</p>
JC	Determines address modifier response of the board. Installed jumper indicates response to short nonprivileged I/O access.	 <p>NOT INSTALLED</p>
JA, JB	Determines the digital code written to the DAC. JB installed gives two's complement binary coding. JA installed gives offset binary coding.	
JD	Installation of this jumper enables the program controlled start convert mode as detailed in "Program Control Update Mode" on page 4-4.	 <p>NOT INSTALLED</p>
JE	Installation of this jumper enables the external start convert mode as detailed in "External Trigger Update Mode" on page 4-4. Jumper JD must also be installed to enable this mode.	 <p>NOT INSTALLED</p>

Before Applying Power: Checklist

Before installing the board in a VMEbus system go through the following checklist to verify that the board is ready for the intended operation:

1. Have the chapters on Theory and Programming of the DAC board, Chapters 3 and 4, been read and applied to system requirements?
2. Review Table 2-1 on page 2-3 to verify the factory installed jumpers and board address switches are set to what is desired.
To change DAC board switches (S1 and S2) refer to “Board Address Selection Switches” on page 2-5.
To change address modifier response jumper (JB) refer to “Address Modifier Response Selection” on page 2-7.
3. To change the DAC digital code selection refer to “Digital Code Selection” on page 2-8.
4. To use either the program controlled start convert mode or the external start convert mode refer to “Program Controlled and External Start Convert Mode” on page 2-9.
5. Has the cable, with proper mating connector, been connected to the analog output connector (P3)? Refer to “Connector Descriptions” on page 2-10.

Digital-to-Analog Converter Board Installation

After steps 1 through 5 have been reviewed, the DAC board may be installed in a VMEbus system. (Do not install or remove the board with power ON). The DAC board may generally be installed in any slot position, except slot "one" which is usually reserved for the master processing unit.

Board Address Selection Switches

There are two address select DIP switches on-board the Digital-to-Analog Converter Board. Each individual switch corresponds to an address bit, or is not used. If the switch is ON the corresponding address bit is compared to a logic "zero". All corresponding address bits must compare with the switch positions during a *Write/Read* of the DAC board. Each switch corresponds to the address bits as shown in Figure 2-1 below. For the board switch locations are shown in Figure 2-2 on page 2-6.

Example: For the Digital-to-Analog Converter Board to respond to a base address of (FXFFBC40_{16}) the S1 and S2 switches would be set accordingly.

Figure 2-1. Address Selection Switches

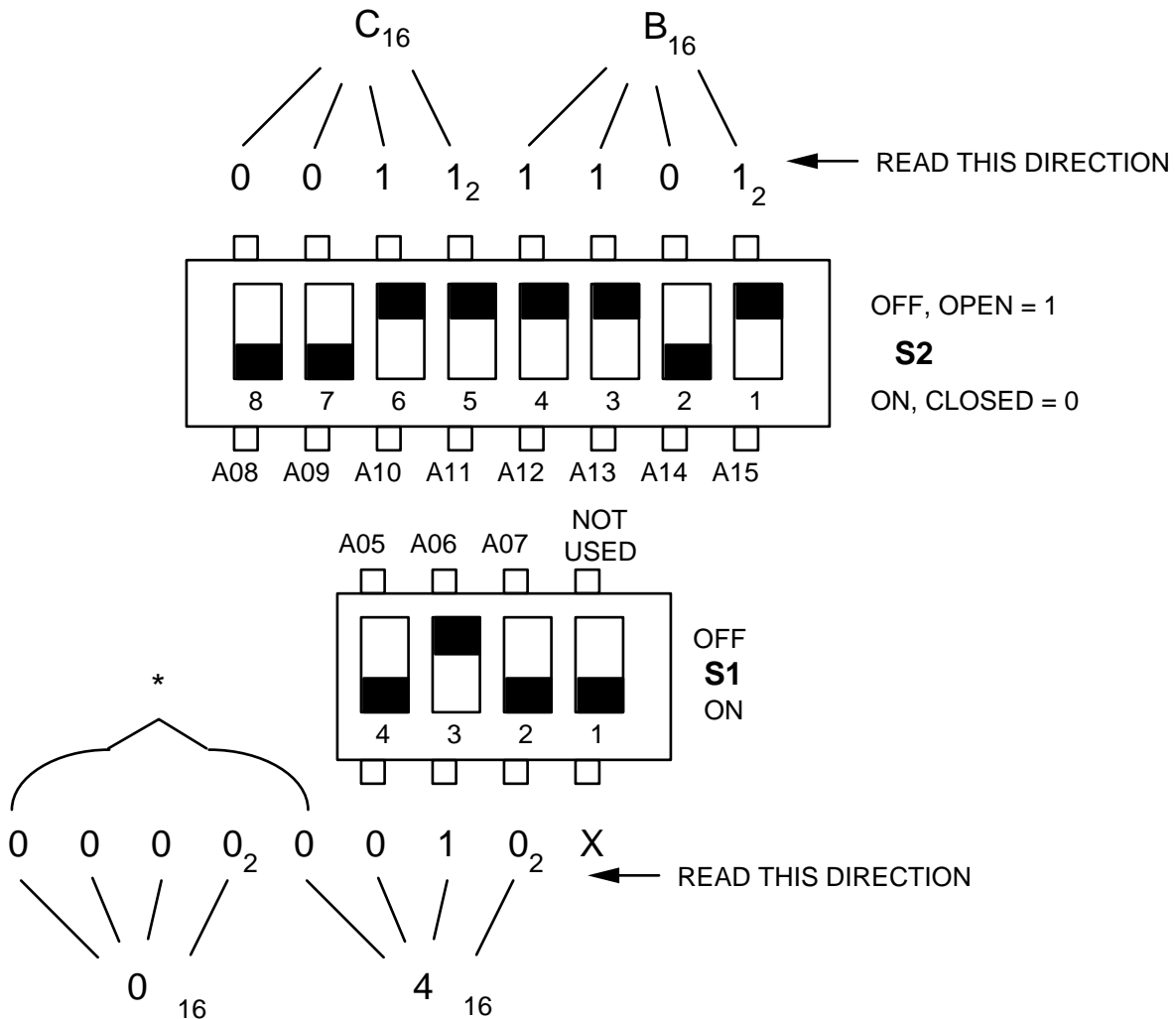

*No switches on-board to represent bits A00 through A04. These bits are understood to be "zeros".

Figure 2-2: Jumper and Switch Locations on the Digital-to-Analog Converter Board

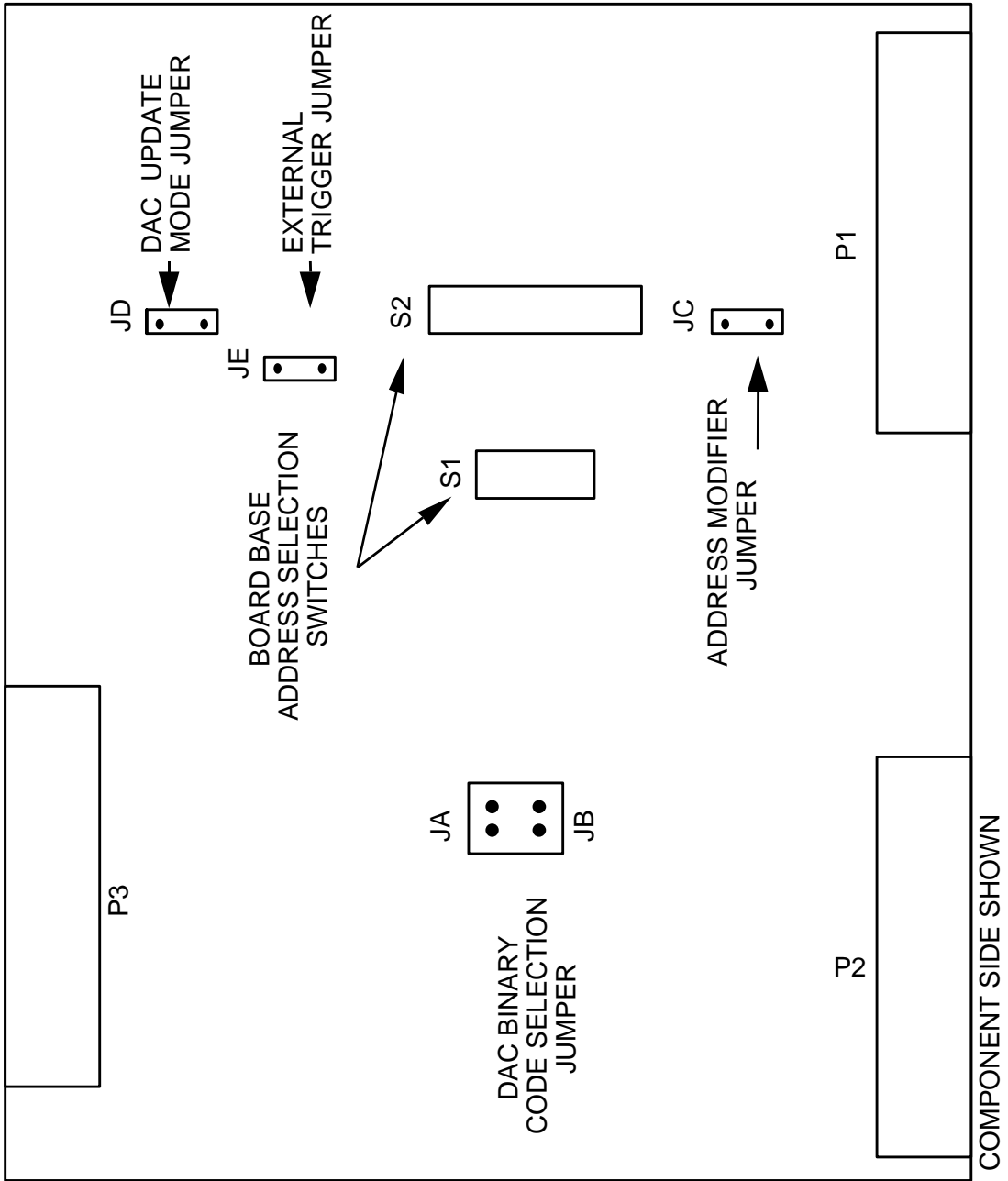

Address Modifier Response Selection

The DAC board is memory mapped in the short I/O address space as described in Chapter 3. The DAC board will respond to either of the two address modifier codes that may be issued to the DAC board by a CPU board during a Write or Read cycle. The DAC board is factory set to respond to supervisory short I/O access. To select short nonprivileged I/O access, and install the jumper at jumper location (JC).

Digital Code Selection

The DAC board is factory configured for offset binary coding. To change the DAC input coding to two's complement binary, remove jumper JA and install jumper JB (see Figure 2-3 below).

Figure 2-3: Digital Code Selection

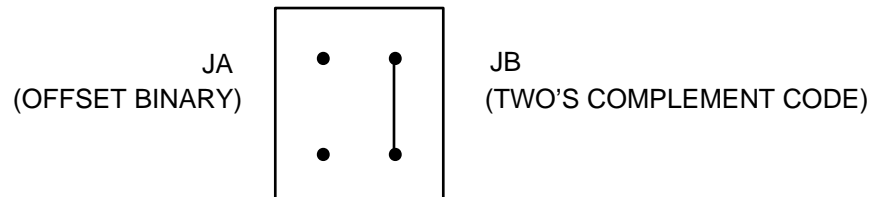

Program Controlled and External Start Convert Mode

The PROGRAM CONTROLLED START CONVERT MODE is enabled by inserting jumper JD. This mode is detailed in “Program Control Update Mode” on page 4-4 and “Delayed DAC Update Mode” on page 3-6. With no jumper installed at JD, the board operates in the IMMEDIATE DAC UPDATE MODE as described in “Immediate DAC Update Mode” on page 4-3 and “Immediate DAC Update Mode” on page 3-3.

Installing jumper JE enables the EXTERNAL START CONVERT MODE. Jumper JD must also be installed (refer to “External Trigger Update Mode” on page 4-4). The external trigger is buffered in through the P2 connector pin A25 with an associated digital ground wire at pin A26. The locations of jumpers JD and JE are shown in Figure 2-2 on page 2-6.

Connector Descriptions

Two 96-pin DIN type connectors, P1 and P2, connect the DAC board to the VMEbus backplane. The primary connector, P1, contains the address data and control lines and all additional signals necessary to control data transfer and other bus functions. See Figure 2-4 on page 2-11 and Table 2-2 on page 2-12 for the P2 connector signal assignments.

The P3 connector is a Panduit 32-pin male connector type, number 120-332-033A. The matching Panduit connector for the input cable is a female connector type, number 120-332-435E. This connector handles the 16 analog outputs, each with an associated analog ground wire. See Figure 2-5 on page 2-13 and Table 2-3 on page 2-14 for P3 connector assignment.

Figure 2-4: P2 Connector – Pin Assignments

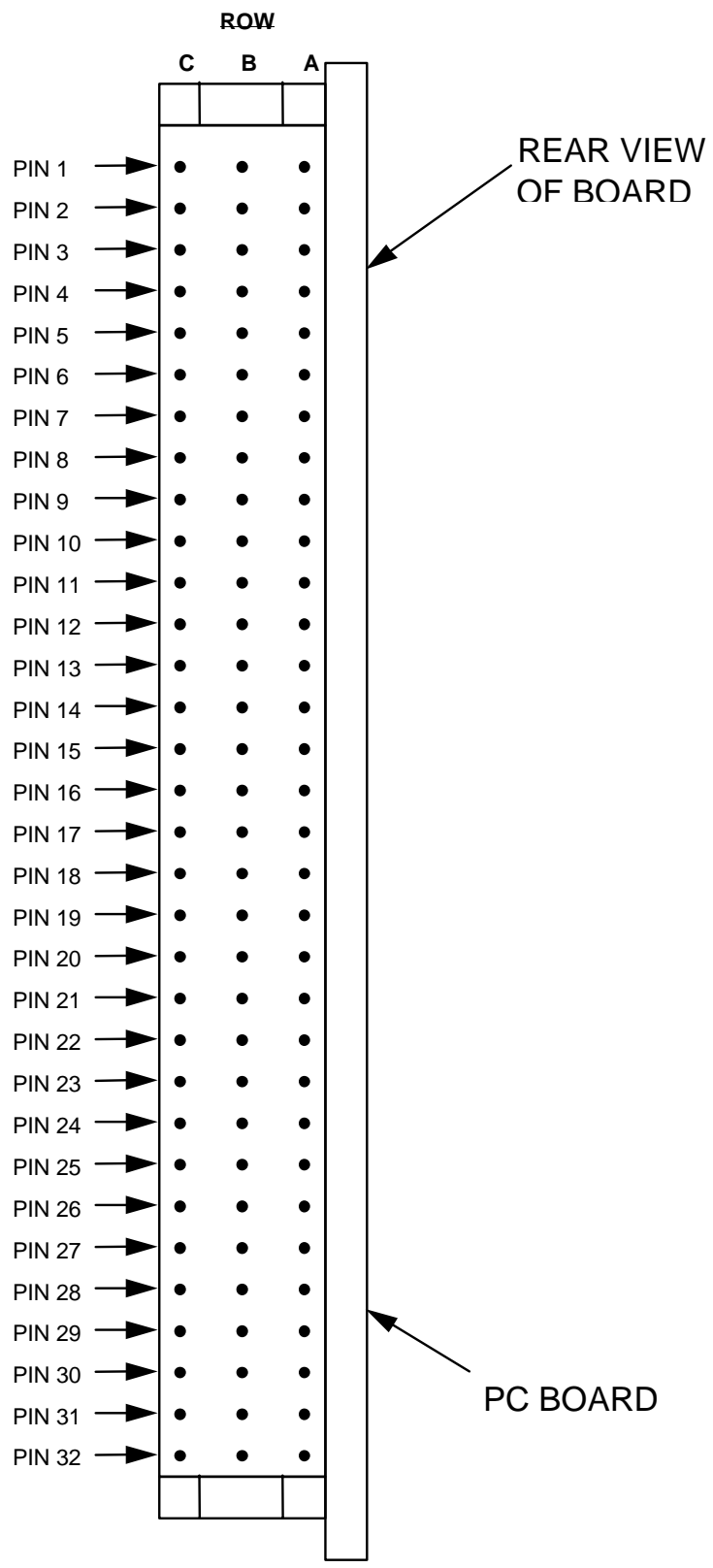
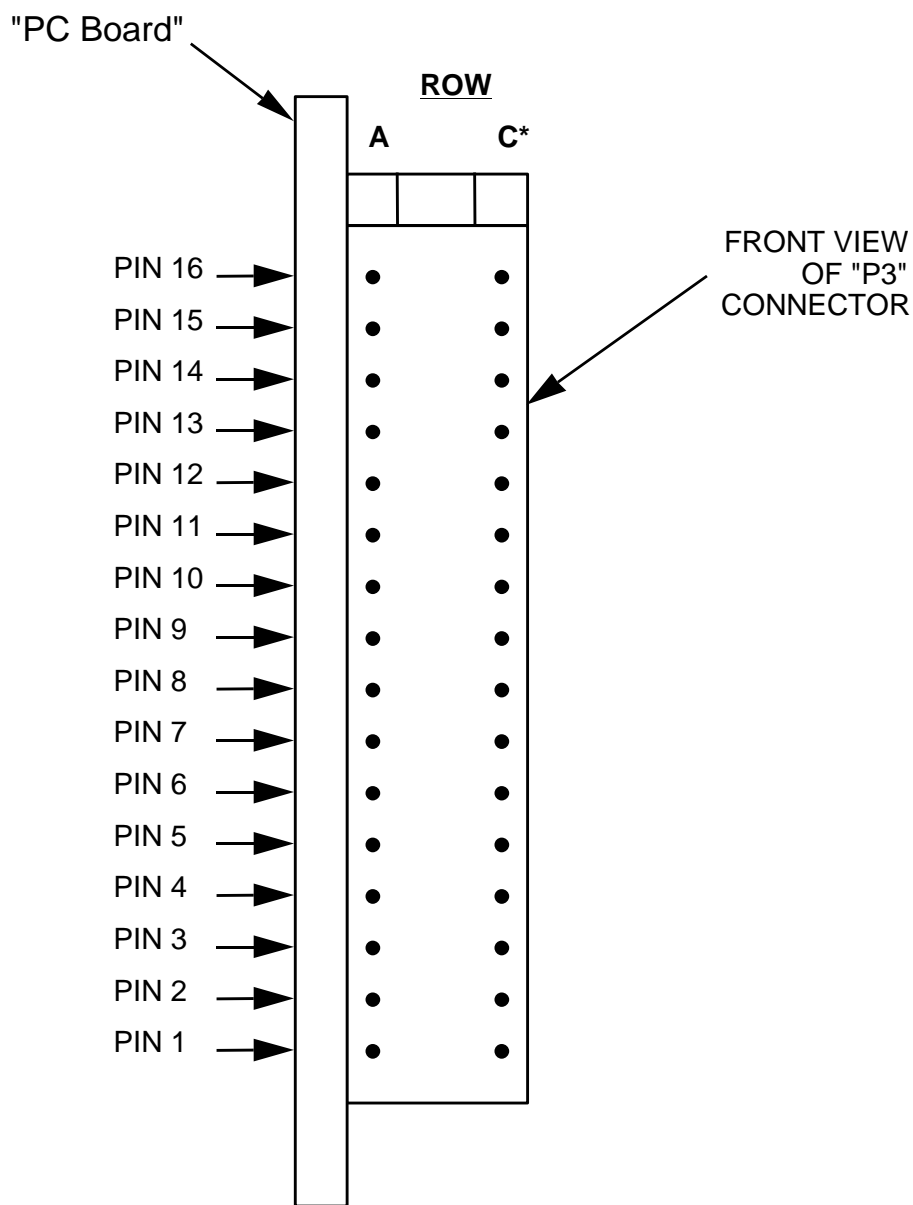

Table 2-2: P2 Connector

Pin Number	Row A Signal Mnemonic	Row B Signal Mnemonic	Row C Signal Mnemonic
1	ANA COM	+5V	
2	ANA COM	GND	
3	ANA COM		
4	ANA COM		
5	ANA COM		
6	ANA COM		
7	AINTSTBS		
8	ANA COM		
9			
10	ANA COM		
11			
12	ANA COM	GND	
13		+5V	
14	ANA COM		
15	GND SEN		
16	ANA COM		
17			
18	ANA COM		
19			
20	ANA COM		
21			
22	ANA COM	GND	
23	ANA COM		
24	ANA COM		
25	EXTSCL		
26	GND		
27			
28			
29			
30			
31		GND	
32		+5V	

Figure 2-5: P3 Connector – Pin Assignments



*Row C pins are all analog common

Table 2-3: P3 Connector

Pin Number	Row A Signal Mnemonic	Row B Signal Mnemonic	Row C Signal Mnemonic
1	ANA COM		ANA COM
2	AN00		ANA COM
3	AN01		ANA COM
4	AN02		ANA COM
5	AN03		ANA COM
6	AN04		ANA COM
7	AN05		ANA COM
8	AN06		
9	AN07		
10			
11			
12			
13			
14			
15			
16			

DAC Zero Offset and Gain Calibration

Note

This procedure assumes that the offset binary coding jumper (JA) is selected.

1. Remove power from the Digital-to-Analog Converter Board.
2. Remove any cable connected to the P3 connector.
3. Remove the Digital-to-Analog Converter Board from the chassis assembly and install a VMEbus Extender board in its place.
4. Install the Digital-to-Analog Converter Board onto the VMEbus Extender board.
5. Apply power to the module and allow 15 minutes for Temperature Stabilization before making any measurements.
6. Using the IMMEDIATE UPDATE MODE write digital code 4100 HEX to the CSR location XXXX0070. This HEX code is the Control Word for output to the Digital-to-Analog Converter Board's P3 connector.
7. Write 8000 HEX to each of the eight DAC channels at addresses XXXX0060 through XXXX006E.
8. Using a 6-digit multimeter, monitor each DAC output at the P3 connector. Connect the negative lead to connector P3 pin C2. Adjust each DAC's offset potentiometer for a voltage of $0.0000 \pm 60 \mu\text{V}$. Refer to Table 2-4 below and Figure 2-6 on page 2-16 for the Potentiometer Location and P3 connector pin for each channel.

Table 2-4. Digital-to-Analog Converter Board Calibration Table

Channel	Offset Pot	Gain Pot	P3 Connector
1	R23	R21	A2
2	R19	R17	A3
3	R31	R29	A4
4	R27	R25	A5
5	R3	R1	A6
6	R7	R5	A7
7	R15	R13	A8
8	R11	R9	A9

9. Repeat Step 7 using digital code FFFF HEX.
10. Using the multimeter, monitor each DAC output at the P3 connector. Connect the negative lead to connector P3 pin C2. Adjust each DAC's gain potentiometer for a voltage of $9.99969 \pm 60 \mu\text{V}$. Refer to Table 2-4 above and Figure 2-6 on page 2-16 for the Potentiometer Location and P3 connector pin for each channel.
11. Remove extender and re-install board into the chassis. Calibration completed.

Figure 2-6: Calibration Adjustment Locations

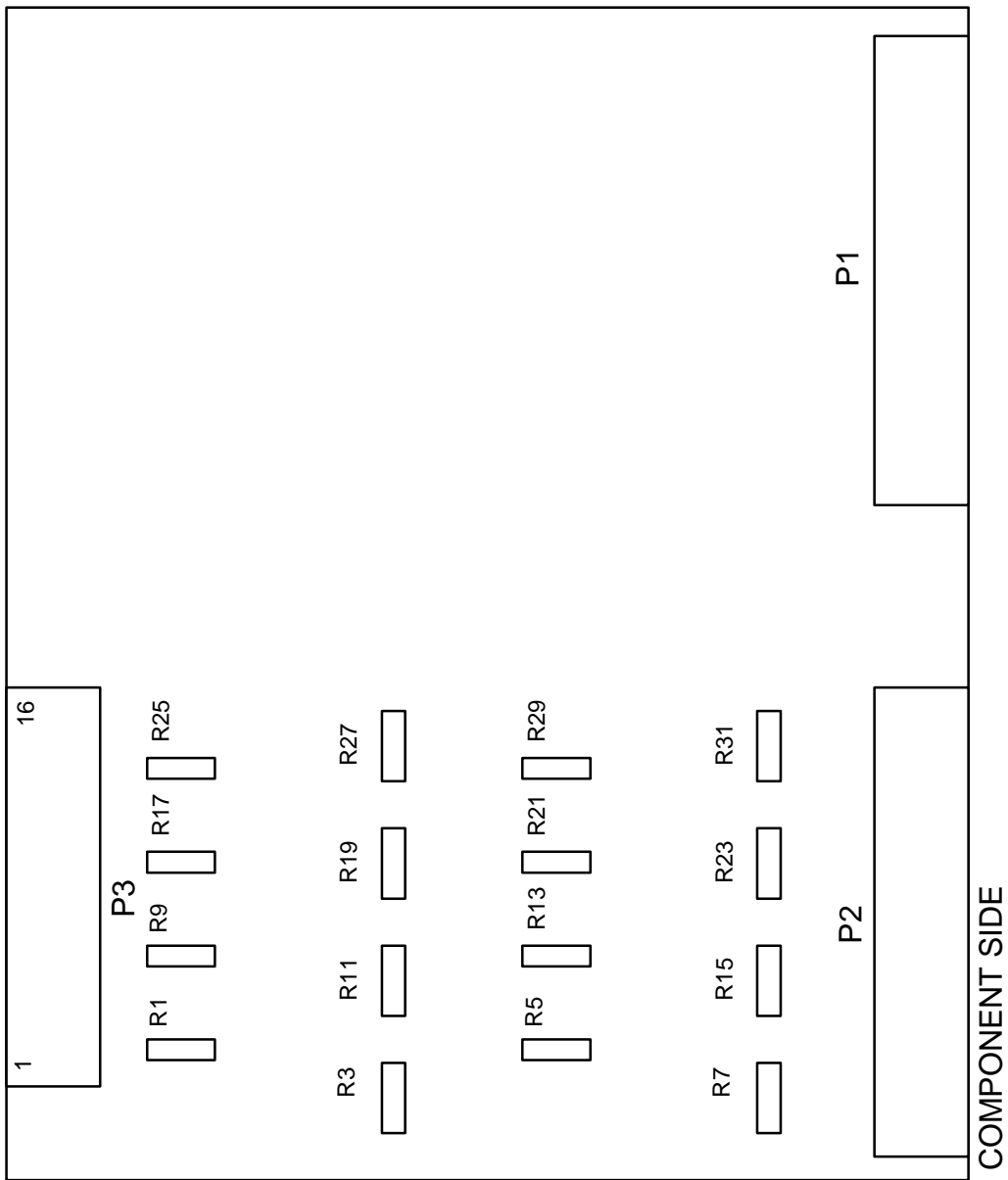

Chapter 3

Programming

This chapter contains programming instructions for the Digital-to-Analog Converter Board, and is divided into the following sections:

- Introduction to Programming the Digital-to-Analog Converter Board
- Digital-to-Analog Converter Board Programming Options
- Delayed DAC Update Mode
- Test Mode Programming
- Program Example (Delayed DAC Update Mode)

Introduction to Programming the Digital-to-Analog Converter Board

The Digital-to-Analog Converter Board is memory mapped in the short I/O address space. The board occupies 16 successive word locations in the VME short I/O address space of 65,535 bytes. Only the first nine word locations are actually used by the board. The short I/O space is located from XXXX0000 HEX to XXXXFFFF HEX. The address bits A31 to A16 are CPU dependent. Each *Read* cycle may be either a word or byte transfer. The board base address may be selected by DIP switches as shown in “Board Address Selection Switches” on page 2-5. Tables 3-1 and 3-2 below represent the DAC address map assuming the factory set base address of XXXX0060 HEX.

Table 3-1: Control and Status Register

Control and Status Register (CSR) (Read/Write) Address \$XXXX0070							
D15	D14	D13	D12	D11	D10	D09	D08
Not Used	Control and Status Bits						

Control and Status Register (CSR) (Read/Write) Address \$XXXX0070							
D07	D06	D05	D04	D03	D02	D01	D00
Not Used							

Table 3-2: DAC Channels Address Map

DAC Channels (0 to 7) Address (Write Only)		
Address	D15 (MSB)	D00 (LSB)
XXXX0060	DAC OUT 0	
XXXX0062	DAC OUT 1	
XXXX0064	DAC OUT 2	
XXXX0066	DAC OUT 3	
XXXX0068	DAC OUT 4	
XXXX006A	DAC OUT 5	
XXXX006C	DAC OUT 6	
XXXX006E	DAC OUT 7	

Note

Jumper JC determines whether the board operates in Short Supervisory I/O Access or Short NonPrivileged I/O Access. With the jumper installed Short NonPrivileged I/O Access is selected.

Tables 3-1 and 3-2 above shows addressing information for 16-bit word transfers. Data may be transferred to the DACs in 8-bit format. When using byte format, the low byte is always transferred first then the high byte next. For example, assuming a board base address of XXXX0000 HEX, a low byte transfer (D7 to D0) to Channel 0 is written to address XXXX0001 HEX. The high byte of data (D15 to D8) is then written to address XXXX0000 HEX.

Digital-to-Analog Converter Board Programming Options

There are two types of registers that must be written to for proper operation of the DAC board. One is the CSR, and the other is the DAC. The order in which they are written to may differ depending on the method used to start a conversion.

Immediate DAC Update Mode

The IMMEDIATE DAC UPDATE MODE is described in “Program Control Update Mode” on page 4-4 and the board is configured for this mode when received from the factory. Once this has been set up, a 16-bit word can be written to any DAC channel where it will begin immediate analog conversion. When byte transfer (8-bit) is used to load the DAC channel, conversion begins immediately upon the loading of the high byte (D15 to D8).

All eight DAC channels can be initiated to a value, as described in the preceding paragraph, before they are connected to the external circuitry. After powering up the board, load the DAC channels with the initial 16-bit word (or two 8-bit bytes) required (positive true offset binary or binary two's complement coding, Table 3-3 below). A control word can then be written to the CSR to enable the DAC outputs to the P3 connector. The CSR bit description for this mode of operation is detailed in Table 3-4 on page 3-4 and Table 3-5 on page 3-5.

Table 3-3. DAC Data Format Analog Output versus Digital Input (±10 V Scale)

Offset Binary Coding									
Digital Input Code				Analog Output Voltage		Two's Complement			
(MSB) D15			(LSB) D0						
0000	0000	0000	0000	-10.000V	-Full Scale	1000	0000	0000	0000
0100	0000	0000	0000	-5.000V	-1/2 Scale	1100	0000	0000	0000
1000	0000	0000	0000	0.000V	Zero	0000	0000	0000	0000
1000	0000	0000	0001	305µV	+LSB	0000	0000	0000	0001
1100	0000	0000	0000	+5.000V	+1/2 Scale	0100	0000	0000	0000
1111	1111	1111	1111	9.99969V	+Full Scale	0111	1111	1111	1111

The analog output may be calculated by the input code written by the processor to the selected DAC channel as follows:

$$\text{Analog Output} = -10 \text{ V} + \left(\left[(\text{Digital Input Code in decimal}) \times 20 \right] / 65536 \right)$$

Example: The analog output for a digital input of 0A00H would be:

1. 0A00H decimal equivalent is 2560
2.
$$\text{Analog out} = -10 \text{ V} + \left((2560) \frac{20}{65,536} \right)$$

$$= -9.21875$$

Table 3-4. Control Register Data Format and Definitions

Control and Status Register							
D15	D14	D13	D12	D11	D10	D09	D08
Not Used					Not Used		

Control and Status Register							
D07	D06	D05	D04	D03	D02	D01	D00
Not Used							

- Bit D15:** Not used.
- Bit D14:** A low state turns the Fail LED ON. A high state turns the Fail LED OFF. At power-up this control bit is low.
- Bit D13:** A high state enables the selected analog output to pass out the P2 connector on test bus 2 (AOTESTBS). At power-up this control bit is low.
- Bit D12:** A high state enables the selected analog output to pass out the P2 connector on test bus 1 (AINTTESTBS). At power-up this control bit is low.
- Bit D11⁽¹⁾:** When written high, it engages one analog output from the DAC to one of two test buses. Used in conjunction with D12 and D13 to determine which test bus is selected. At power-up this control bit is low which disengages the test buses.
- Bit D10:** Not used.
- Bit D09:** Program Control Start Convert. When set to a "one", it generates a signal that transfers contents of previously loaded DACs to the second rank register and updates the analog output.
- Bit D08:** Don't care
- Bits 07 through 00:** Not used.

(1) Channel selection for muxing one of the outputs to either test bus is achieved by writing the CSR data to the data address + 10H. See "Test Mode Programming" on page 3-7 for additional information.

Table 3-5: Programming the Control and Status Register for Different Analog Output Variations – Bit Definitions

Analog Output Over TEST BUS 1 (AINTTESTBS)							
D15	D14	D13	D12	D11	D10	D09	D08
Not Used	1	0	1	1	Not Used	0 or 1	0

Analog Output Over TEST BUS 2 (AINTTESTBS)							
D15	D14	D13	D12	D11	D10	D09	D08
Not Used	1	1	0	1	Not Used	0 or 1	0

Analog Output Over TEST BUS 1 and Over P3 Connector to Field-connected Device (Used for Real-time Fault Detection of DACs)							
D15	D14	D13	D12	D11	D10	D09	D08
Not Used	1	1	0	1	Not Used	0 or 1	1

Analog Output Over P3 Connector Only							
D15	D14	D13	D12	D11	D10	D09	D08
Not Used	1	0	0	0	Not Used	0 or 1	1

Delayed DAC Update Mode

The DELAYED DAC UPDATE MODE operation is described in “Delayed DAC Update Mode” on page 4-4. This mode must have previously been enabled by the jumper configuration in “Program Controlled and External Start Convert Mode” on page 2-9. There are two ways for a DAC channel to be updated after the 16-bit word is loaded into the DAC's first register. The first way is under program control when data bit D9 is written high to the CSR. It should be noted that when setting D9 to initiate the DAC update that control bits D8, and D11 through D14 should be set or reset according to where the user wants the converted output to be routed, (refer to Table 3-4 on page 3-4 and Table 3-5 on page 3-5). Also, a previously loaded DAC may be updated by an external trigger input from another device. A programming example of the DELAYED DAC UPDATE MODE is detailed in “Program Example (Delayed DAC Update Mode)” on page 3-9.

Test Mode Programming

Any of the eight DAC outputs may be selected to pass to an ADC board over test bus 2 to verify the DAC outputs. If a MUX is present in the analog backplane then any DAC output can be selected to go to that board for test purposes over test bus 1. Generally the programming sequence for utilizing one of the two test buses is as follows:

If IMMEDIATE DAC UPDATE MODE is employed, then a Control Word should first be written to the CSR. This Control Word information includes which test bus the DAC output is to be routed to, and whether the output is to be isolated or connected to the P3 connector (refer to Table 3-4 on page 3-4 and Table 3-5 on page 3-5). The DAC to be updated is then loaded with a 16-bit word. The channel is updated and passes out the selected test bus.

An output may also be updated under program control to route to a specified test bus. The board must have previously been jumpered to accommodate the DELAYED DAC UPDATE MODE as shown in "Program Controlled and External Start Convert Mode" on page 2-9. The programming sequence is as follows:

First, a 16-bit word or two 8-bit bytes are written to the address of the DAC channel that is to be updated. The data is stored in the DAC Register and will be converted by setting the proper bits in a *Write* cycle to the CSR. The CSR must be written to at the same address as that of the DAC channel that has previously been loaded plus 10 HEX. For example, if the user wanted to convert Channel no. 2 which was written to address XXXX0062 HEX, then the Control Word would be written to address XXXX0072 HEX (XXXX0062 and 10 HEX). Data bit D09 when written as "one" to the CSR initiates the analog conversion of the previously stored 16-bit word.

The test modes can only be used if an ADC board exists in the same GE Fanuc analog (P2) backplane as the Digital-to-Analog Converter Board.

Program Example (Delayed DAC Update Mode)

In the programming example in “Test Mode Programming” on page 3-7, all eight DAC converters were loaded with a full scale value of FFFH in the IMMEDIATE UPDATE MODE. For illustration purposes the same result will be obtained by this programming example by using the DELAYED DAC UPDATE MODE. The DELAYED DAC MODE is jumper-selectable as described in “Program Controlled and External Start Convert Mode” on page 2-9.

The programming sequence in a flowchart is shown in Figure 3-2 on page 3-12. In the following program example all eight DAC channels are loaded with new data, and then updated under program control. Alternatively, if previously enabled, an external trigger input could have initiated the DAC conversion process.

Figure 3-1: DAC Programming Sequence (Immediate DADC Start Convert Mode)

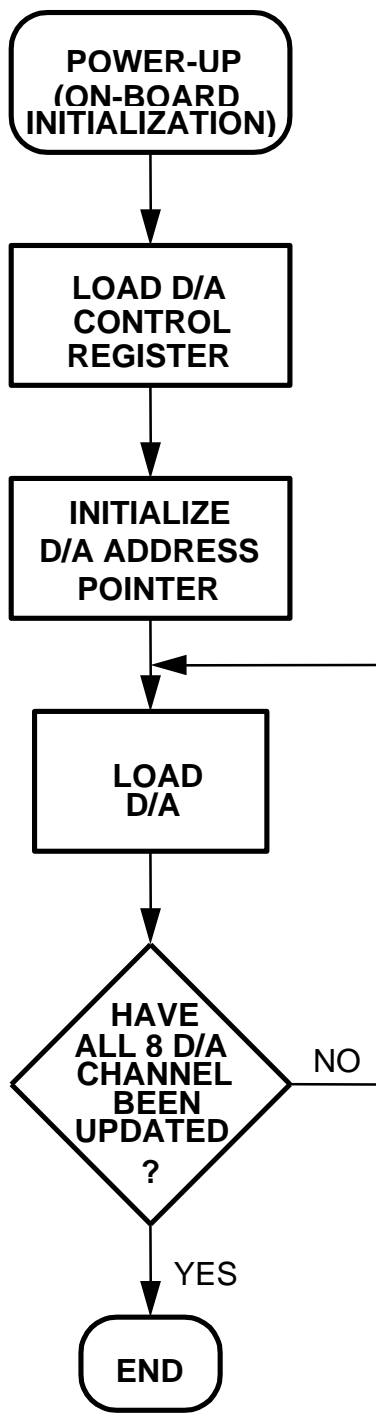

Table 3-6: Analog Output Control in Immediate DAC Update Mode

Analog Out Pathway	Control Word (D15 to D0) Hex Value
P3 Connector	4100
AOTESTBS (TEST BUS 2)	6C00
AINTESTBS (TEST BUS 1)	5C00
AOTESTBS and P3 Connector	6D00

Figure 3-2: DAC Programming Sequence (Delayed DAC Update Mode)

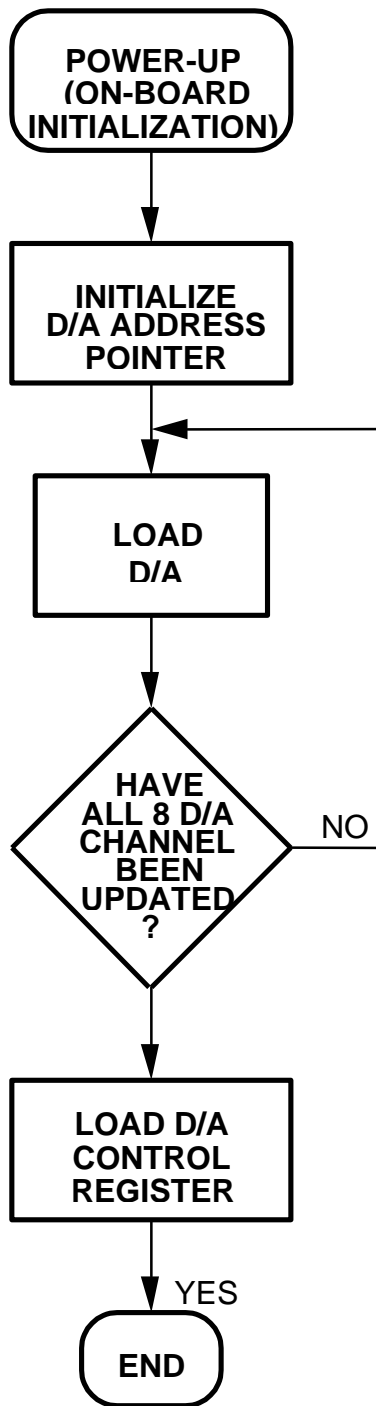

Table 3-7: Analog Output Control in Delayed DAC Update Mode

Analog Out Pathway	Control Word (D15 to D0) Hex Value
P3 Connector	4300
AOTESTBS (TEST BUS 2)	6E00
AINTESTBS (TEST BUS 1)	5E00
AOTESTBS and P3 Connector	6F00

This chapter discusses the operation of the Digital-to-Analog Converter Board, and is divided into the following sections:

- Operational Overview
- Immediate DAC Update Mode
- Delayed DAC Update Mode
- VMEbus Interface Description

Operational Overview

The Digital-to-Analog Converter Board performs digital-to-analog conversion on 16-bit positive true offset binary or two's complement coded words, with an analog output range of -10 to +10 V. This provides for a resolution of 305 μ V for each digital input of 1 LSB change. The buffered output voltage settles to within 1/2 LSB in 10 μ s.

The DAC offers a Digital-to-Analog Integrated Circuit (IC) per channel. A Control and Status Register (CSR) is loaded by the processor and this register controls the functioning of the board. The processor can read the CSR at any time. The DAC board functional block diagram is shown in Figure 4-1 on page 4-5. Double-buffered data latches precede each of the eight DACs. The data latches allow versatility in the way that the DAC analog output may be updated.

There are three methods by which new data can be converted by a DAC.

Each method is enabled/disabled by on-board jumpers and is further controlled by a CSR that must be loaded by the user (the CSR contents are described in Tables 3-1 and 3-2 on page 3-2, Table 3-4 on page 3-4, and Table 3-5 on page 3-5).

Immediate DAC Update Mode

The processor unit sends the 16-bit word to be converted to the first register of the selected DAC. If that DAC channel has previously been jumpered to, it will automatically pass the contents of the first DAC register into the second register and update the analog output. There is one jumper that enables/disables all eight DAC channels to be in the IMMEDIATE UPDATE MODE as described above, or in the DELAYED UPDATE MODE. Jumper definition and locations are described in “Program Controlled and External Start Convert Mode” on page 2-9.

Delayed DAC Update Mode

In the DELAYED DAC UPDATE MODE, the processor sends the 16-bit word to be converted to the first DAC register of the selected DAC. The data is stored there and transferred to the second DAC register in one of two possible methods, described below.

Program Control Update Mode

One way for the transfer to occur is by writing a "one" to the Control Register bit D09. When the data is transferred to the second register, digital-to-analog conversion begins and the analog output settles to within 1/2 LSB in 10 μ s. This method of updating the analog output is useful when more than one DAC channel output is desired to change at a precise time. All eight DAC outputs could be synchronized to change at certain periodic intervals under software control.

External Trigger Update Mode

The second method to update the second storage register and the DAC output by an external TTL compatible trigger. This trigger must first have the external trigger circuitry enabled by installing an on-board jumper as described in "Program Controlled and External Start Convert Mode" on page 2-9. The PROGRAM CONTROL UPDATE MODE must also be enabled (refer to "Program Controlled and External Start Convert Mode" on page 2-9). When the external trigger is received (active low for a minimum of 150 ns), the value stored in the first DAC register will be transferred to the second DAC register and begins a conversion. Using this method of updating, all conversions can be synchronized to an external device.

Each of the DAC outputs may be multiplexed one at a time via the test MUX shown in Figure 4-3 on page 4-8. First, a control word must be written to the CSR to establish whether the analog output is to be connected or disconnected from the P3 connector and which one of two test buses the output is to be routed to. The DAC channel to be tested has test data written to it in the IMMEDIATE UPDATE MODE. Address bits A01 through A04 are automatically latched into the Address Register when the board is written to. The outputs of this Address Register select the DAC channel that has just been updated via the test MUX. Test control information previously latched in the CSRs passes the DAC output through the analog test switch to the test bus 2. Test bus 2 is routed via the analog backplane (AMXbus™) to the input of the ADC board where it is available for analog-to-digital conversion. When the ADC completes its conversion, it sends an end-of-convert signal down the P2 backplane to the DAC. This signal removes either of the two test bus outputs from the analog backplane. Along with the test bus 2 signal being sent to the ADC board the analog ground (GND SEN) is switched out to the ADC board. This provides an input to the ADC board, which is similar to a differential signal and is called pseudo-differential. Pseudo-differential solves some of the associated common mode error problems with single-ended signals. The input to the ADC board is referenced to the ground of the DAC board instead of the local ground at the ADC board, effectively canceling out common mode errors associated with different ground potentials at each of the boards.

Figure 4-1: Digital-to-Analog Converter Board Functional Block Diagram

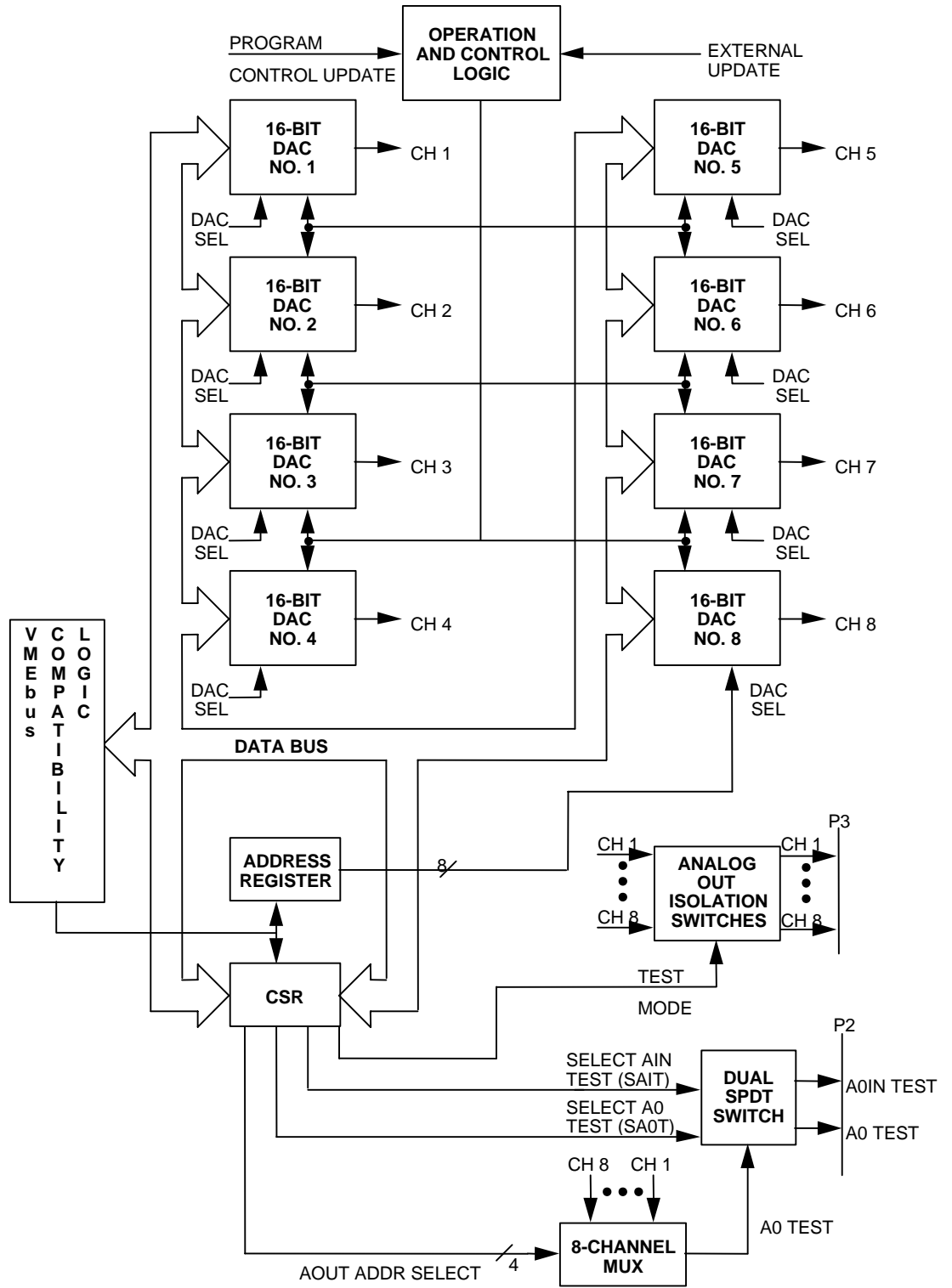

VMEbus Interface Description

The VMEbus interface (Figure 4-4 on page 4-9) contains the necessary logic to interface a DAC board to the VMEbus. The DAC is memory mapped in the VMEbus short I/O address space. During a *Write* cycle to the board, address bits A05 through A15 are compared with the previously selected board address. DIP switches select the board address. If the address compares, then a board select signal is issued. This signal along with the control signals received at the board, gate the data (D0 to D15) to a selected DAC or the CSR on the DAC. Address bits A01 through A03 select one of the eight DAC channels. Data D0 through D15 is latched into the selected DAC Register. Address bit A04 is used to select the CSR.

The DAC circuitry requires +5 V, +15 V, and -15 V, the +5 V is supplied to the board via the P1 and P2 connectors. An on-board DC-to-DC converter generates the +15 V and -15 V for the analog circuitry (refer to Figure 4-5 on page 4-11). Thus, the DAC board only needs +5 V from the chassis power supply.

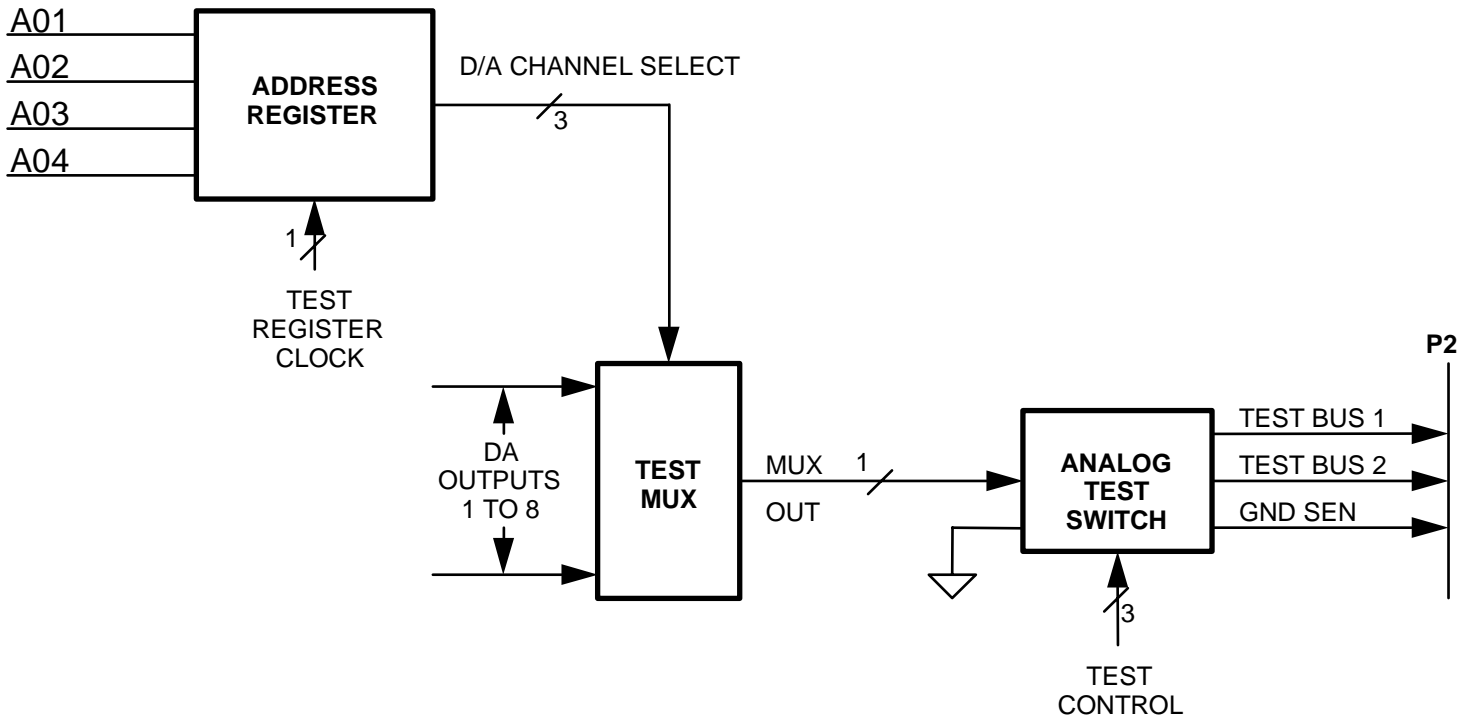

Figure 4-2: Test Bus Logic

Figure 4-3: VMEbus Interface Logic and Interface Signals

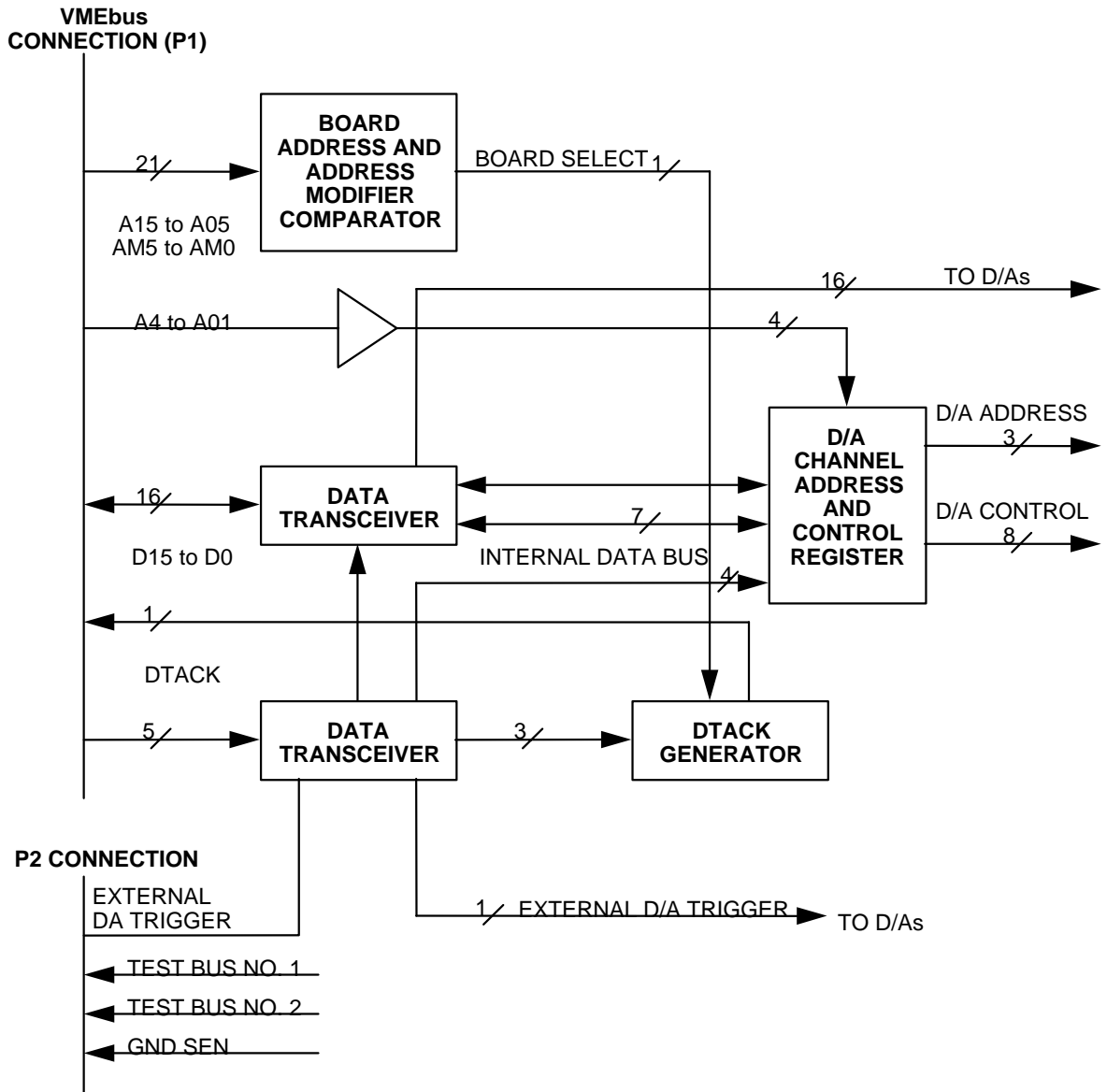
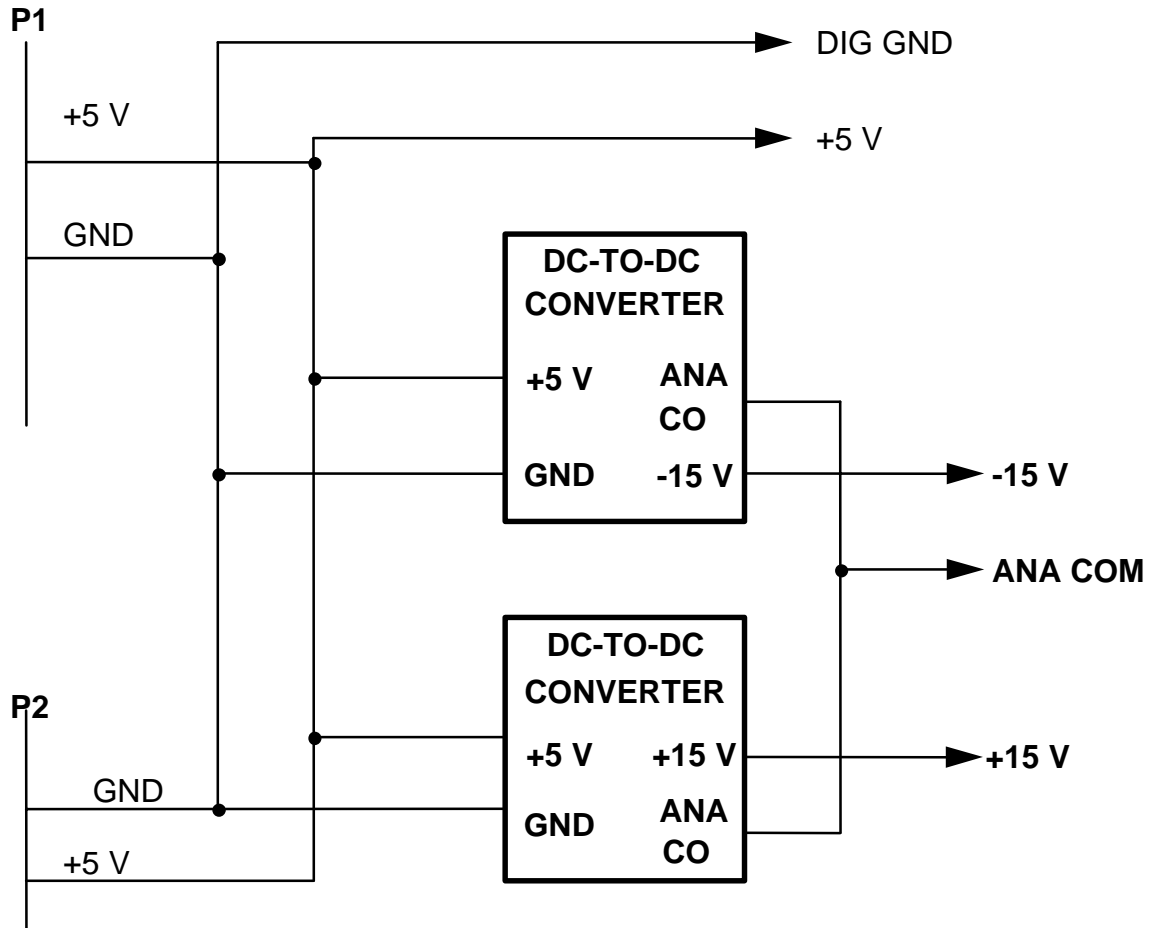

Figure 4-4: Digital-to-Analog Converter Board Power



Chapter 5

Maintenance

This chapter provides information relative to the care and maintenance of the Digital-to-Analog Converter Board.

If the product malfunctions, verify the following:

- Software
- System configuration
- Electrical connections
- Jumper or configuration options
- Boards fully inserted into their proper connector location
- Connector pins are clean and free from contamination
- No components of adjacent boards are disturbed when inserting or removing the board from the VMEbus card cage
- Quality of cables and I/O connections

User level repairs are not recommended. Contact GE Fanuc for a Return Material Authorization (RMA) Number. **This RMA Number must be obtained prior to any return.**