

**GFK-1755**  
**New In Stock!**  
**GE Fanuc Manuals**

<http://www.pdfsupply.com/automation/ge-fanuc-manuals/ocs/GFK-1755>

**OCS**  
**1-919-535-3180**

Installation Requirements for Conformance to Standards

[www.pdfsupply.com](http://www.pdfsupply.com)

Email: [sales@pdfsupply.com](mailto:sales@pdfsupply.com)

**GFK-1755**  
**New In Stock!**  
**~~GE Fanuc~~ Manuals**

<http://www.pdfsupply.com/automation/ge-fanuc-manuals/ocs/GFK-1755>

**OCS**  
**1-919-535-3180**

Installation Requirements for Conformance to Standards

[www.pdfsupply.com](http://www.pdfsupply.com)

Email: [sales@pdfsupply.com](mailto:sales@pdfsupply.com)



*Industrial Control  
Products*

**Installation Requirements for  
Conformance to Standards**

October 06, 1999

GFK-1755

## ***Warnings, Cautions, and Notes as Used in this Publication***

### Warning

**Warning notices are used in this publication to emphasize that hazardous voltages, currents, temperatures or other conditions that could cause personal injury exist in this equipment or may be associated with its use.**

**In situations where inattention could cause either personal injury or damage to equipment, a Warning notice is used.**

### Caution

**Caution notices are used where equipment might be damaged if care is not taken.**

### Note

Notes merely call attention to information that is especially significant to understanding and operating the equipment.

This document is based on information available at the time of its publication. While efforts have been made to be accurate, the information contained herein does not purport to cover all details or variations in hardware or software, nor to provide for every possible contingency in connection with installation, operation, or maintenance. Features may be described herein which are not present in all hardware and software systems. GE Fanuc Automation assumes no obligation of notice to holders of this document with respect to changes subsequently made.

GE Fanuc Automation makes no representations or warranty, expressed, implied, or statutory with respect to, and assumes no responsibility for the accuracy, completeness, sufficiency, or usefulness of the information contained herein. No warranties of merchantability or fitness for purpose shall apply.

The following are trademarks of GE Fanuc Automation North America, Inc.

Alarm Master	CIMSTAR	Helpmate	PROMACRO	Series Six
CIMPLICITY	GENet	Logicmaster	Series One	Series 90
CIMPLICITY 90 – ADS	Genius	ModelMaster	Series Three	VuMaster
CIMPLICITY Power TRAC	Genius PowerTRAC	ProLoop	Series Five	Workmaster

The following are trademarks of Horner APG, LLC.

Cscape	SmartStack	CsCAN
--------	------------	-------



## PREFACE

This manual describes the installation requirements for Industrial Control products used in environments and situations where compliance to standards or directives from the European Union is necessary.

## CONTENT OF THIS MANUAL

**Chapter 1. Installation Guidelines:** Describes installation requirements for GE Fanuc Industrial Control products.

**Chapter 2. Safety-Related Guidelines:** Describes safety guidelines related to the installation of Industrial Control systems in the European Union.

**Appendix A: Product Approvals, Standards, and General Specifications:** This appendix lists product approvals and standards and provides general specifications to which GE Fanuc products must conform when installed in industrial environments.

## TABLE OF CONTENTS

CHAPTER 1: INSTALLATION GUIDELINES.....	7
1.1 Introduction.....	7
1.2 European Union Directives.....	7
1.3 EMC Directive.....	7
1.4 Grounding the Controls Enclosure.....	8
1.5 Cable Shield Clamping Assembly.....	9
1.6 I/O Power Sources.....	9
1.7 General Installation Guidelines.....	9
1.1.7 Operator Control Station (OCS) / Remote Control Station (RCS) / Mini OCS.....	9
1.8 Safety and Reference Earth Ground.....	10
1.8.1 Operator Control Station (OCS) / Remote Control Station (RCS) / Mini OCS.....	10
1.9 Low Voltage Directive.....	11
1.10 Machinery Directive.....	12
CHAPTER 2: SAFETY-RELATED GUIDELINES.....	13
2.1 Introduction.....	13
APPENDIX A: PRODUCT AGENCY APPROVALS, STANDARDS, & GENERAL SPECIFICATIONS ....	17



## CHAPTER 1: INSTALLATION GUIDELINES

### 1.1 Introduction

The installation manuals shipped with your Industrial Control equipment provide detailed information regarding the equipment's proper installation, startup, and use. This manual describes the standards and procedures that Industrial Control products must conform to for installation in environments which must meet the more stringent installation requirements of the European Union.

### 1.2 European Union Directives

The European Union (EU) has implemented directives to harmonize product safety standards within the EU. Compliance with the EU directives is required for products installed within the EU. Products installed within the EU must comply with *each* applicable directive.

Two EU directives apply *directly* to GE Fanuc Industrial Control products:

- a. The **EMC Directive (89/336/EEC, 92/31/EEC, 93/68/EEC)** deals with electromagnetic emissions and immunity.
- b. The **Low Voltage Directive (73/23/EEC, 93/68/EEC)** deals with electrical safety.

GE Fanuc Industrial Control products will be CE-marked to indicate compliance with the EMC Directive. In addition, GE Fanuc will issue Declarations of Conformity that specify the directive(s) and the catalog numbers of the products covered. Programmable Control products must be installed using the instructions in the Installation Manuals and in the applicable sections of this manual.

Manufacturers of machines to be installed within the EU must also comply with the following directive:

The **Machinery Directive (89/392/EEC [Machinery Directive], 91/368/EEC, 93/44/EEC, 93/68/EEC, [Global Directive])** deals with machine safety.

### 1.3 EMC Directive

The EMC Directive is concerned with the immunity of electrical equipment to a variety of interference sources and the emissions from electrical equipment, which can interfere with the operation of other equipment. The EMC Directive applies to complete installations, and since GE Fanuc products are included in the installation, GE Fanuc is supporting the EMC Directive by testing and CE marking a subset of our equipment.

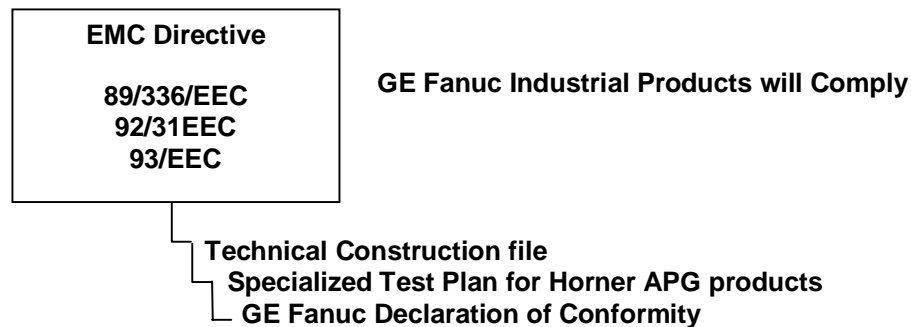

Figure 1-1 GE Fanuc's Path to Comply with the EMC Directive



The following section specifies additional installation and application practices necessary to meet the EMC Directive for wiring that leaves the control cabinet and travels through a factory environment. Wiring that leaves the cabinet may be exposed to interference sources corresponding to the standards and levels specified in Appendix A. The installation practices found in the individual product installation manuals must also be followed.

#### 1.4 Grounding the Controls Enclosure

Locally applicable grounding safety regulations and machinery directives shall be followed for providing a protective ground to earth. **In addition, the following safety guidelines should be followed:**

1. Ground conductors shall be as short and as large in size as possible. The conductors must always be large enough to carry the maximum short circuit current of the path being considered. Braided straps or ground cables (typically green insulation with a yellow tracer - AWG #12 (3.3 mm<sup>2</sup>) or larger) can be used to minimize resistance.
2. The PLC equipment, other control equipment, and the machine shall be interconnected to maintain a common earth ground reference (sometimes referred to as the machine chassis ground).
3. Ground conductors shall be connected in a tree fashion with branches routed to a central earth ground point. This ensures that no ground conductor carries current from any other branch. This method is shown in the following figure.

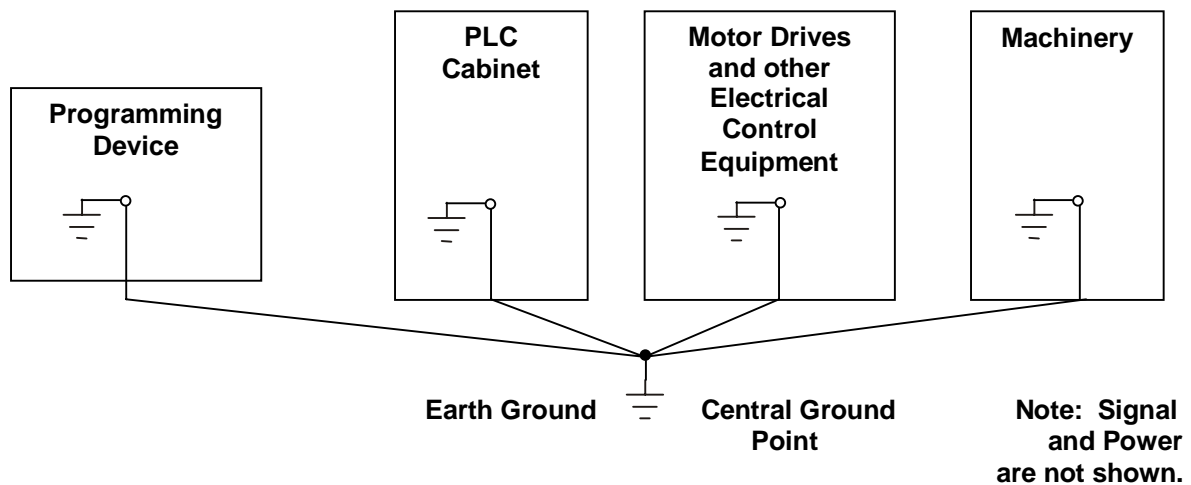

Figure 1-2 Recommended System Grounding

The EMC ground deals with the ability of the system to conduct interference energy transformed into a high frequency and high amplitude current to the machine chassis without causing secondary interference. **The EMC ground requires the following:**

1. The EMC ground must be a low impedance, low inductance path to the machine chassis ground.
2. The baseplate on which the product is mounted should be connected to the machine chassis ground by a wire with a 10:1 length-to-width ratio to provide a high frequency path. (A typical installation simulated for EMC testing used a 2m 12 AWG wire.)

### 1.5 Cable Shield Clamping Assembly

A cable shield clamping assembly (IC697ACC736) is available from GE Fanuc to provide higher EMC immunity for shielded cables in severe industrial environments. This assembly provides a high frequency ground for shielded cables. (A set of 12 additional cable clamps can be ordered - IC697ACC737.) Refer to the GE Fanuc manual for detailed installation and usage information about the assembly.

### 1.6 I/O Power Sources

All power sources needed by the PLC equipment for I/O (discrete and analog) must be appropriately conditioned to not exceed the I/O EMC levels specified in Appendix A for EN61000-4-4:1995 and EN61000-4-5:1995.

### 1.7 General Installation Guidelines

In order to meet CISPR (EN 55011) Group 1, Class A Radiated Emissions levels, all components in the PLC system require the following:

#### 1.1.7 Operator Control Station (OCS) / Remote Control Station (RCS) / Mini OCS

<b>WARNING</b>
----------------

**To provide maximum noise immunity and to ensure minimum EMI radiation, the V- signal (DC power return) shall be connected to Earth Ground at the power supply. The user must ensure that the power supply selected is compatible with this method of grounding.**

1. All components must be mounted in a metal enclosure (or the equivalent) with wiring external to the enclosure routed in metal conduit or the equivalent. All surfaces of the enclosure must be adequately grounded to adjacent surfaces to provide electrical conductivity.
2. The metal conduit (flexible conduit is acceptable) for all wiring external to the cabinet must be mounted to the enclosure using standard procedures and hardware to ensure electrical conductivity between the enclosure and the conduit.
3. The OCS analog input, output, and communication signals need to use Belden Wire # 3084A (thin) or #3082A (thick) or equivalent.

## 1.8 Safety and Reference Earth Ground

### 1.8.1 Operator Control Station (OCS) / Remote Control Station (RCS) / Mini OCS

Figures 1-4 through 1-6. depict grounding for the OCS, RCS, and Mini OCS devices. For additional grounding information, refer to installation chapter in the **Control Station Hardware User Manual** for the OCS, RCS, and SmartStack Modules. Refer to the installation chapter for the Mini OCS in the **Mini OCS Control Station Hardware User Manual**.

**WARNING**

To provide maximum noise immunity and to ensure minimum EMI radiation, the V- signal (DC power return) shall be connected to Earth Ground at the power supply. The user must ensure that the power supply selected is compatible with this method of grounding.

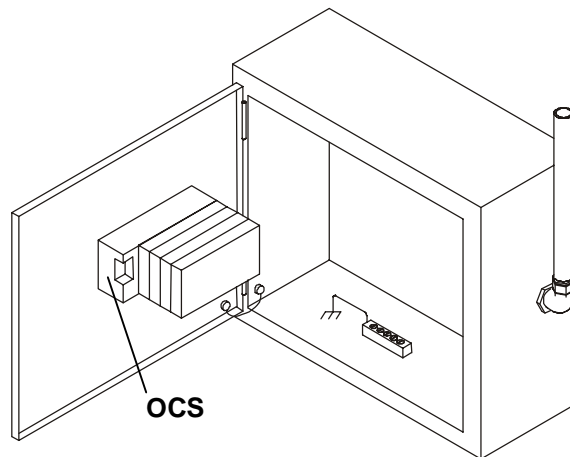

Figure 1-4 Grounding OCS100 or OCS200 (Shown with four SmartStack Modules)

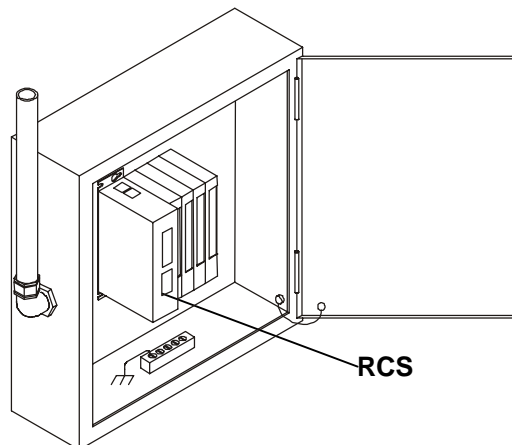
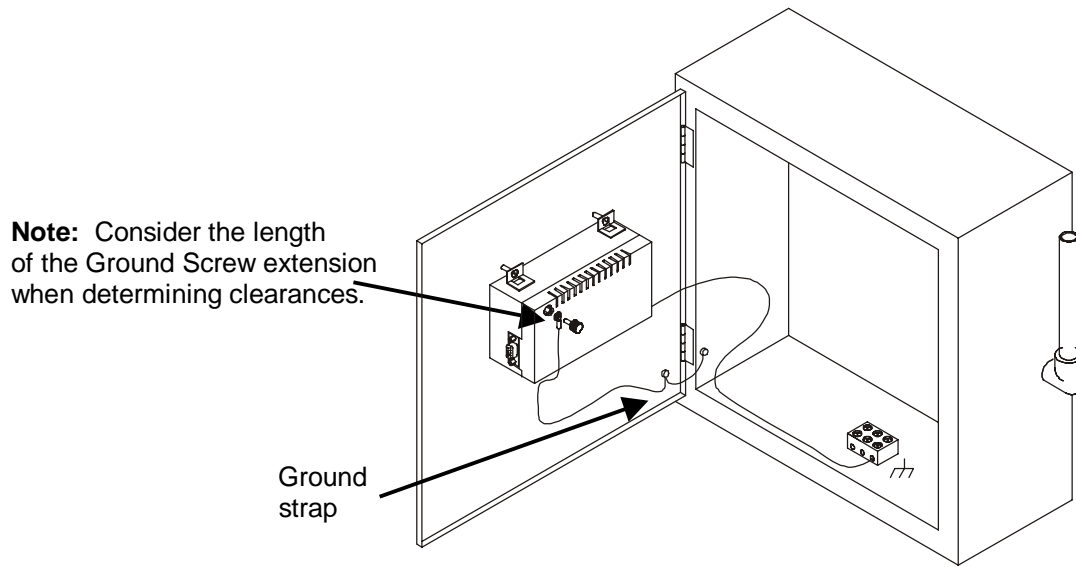

Figure 1-5 Grounding RCS210 (Shown with four SmartStack Modules)



**Figure 1-6 Grounding Mini OCS Modules**

**1.9 Low Voltage Directive**

The Low Voltage Directive applies to products operating above 50 VAC or 75 VDC. The emphasis of the Low Voltage Directive is on safety.

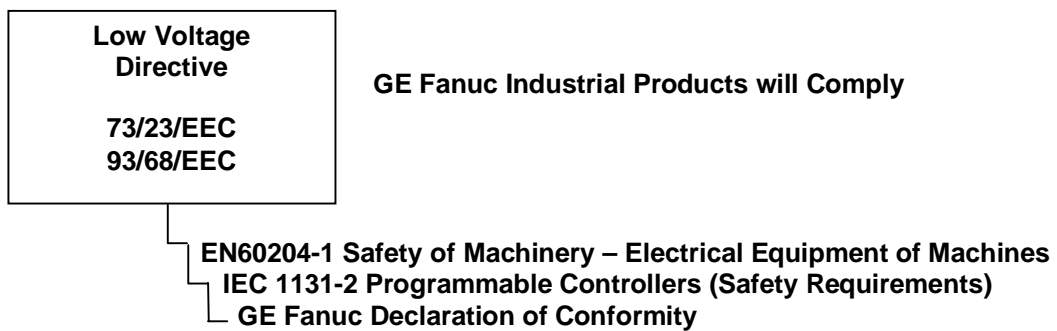

**Figure 1-7 GE Fanuc’s Path to Comply with Low Voltage Directive**

### 1.10 Machinery Directive

The Machinery Directive focuses on the safe operation of the entire machine and is the responsibility of the machine manufacturer.



**Figure 1-8 GE Fanuc's Path for Supporting Machine Manufacturer's Compliance with the Machinery Directive**

GE Fanuc PLC products listed comply with the safety requirements of IEC 1131-2 (Programmable Controllers). When applied in accordance with EN60204-1 (Electrical Equipment of Industrial machines) and GE Fanuc installation instructions, GE Fanuc PLC products allow a machine manufacturer to comply with the electrical safety requirements of the Machinery Directive. Other requirements of the Machinery Directive involving items such as displays, languages, instructions, Emergency Stop functions, machine operation, protective guards and interlocks are the responsibility of the machine manufacturer.

The specific requirements of EN60204-1, IEC 1131-2, and GE Fanuc installation instructions are as follows:

1. Compliance with EN292-1 and EN292-2 (Safety of Machinery) as well as EN60204/IEC204 (Electrical Equipment of Industrial Machines) must be observed during the design phase.
2. The PLC products must be packaged within a metal, IP54 or higher degree of protection enclosure.
3. Negative logic input and output modules cannot be used. (Exception: With safety agency approval, these devices may be used in safety system "H" configurations.)
4. The PLC power supply must be supplied through an IEC-rated isolation transformer.
5. Power supply to the PLC must be controlled to ensure that it does not exceed over-voltage category II per EN60204-1 (IEC 240).
6. Cable shielding and grounding are the responsibility of the machine builder. GE Fanuc's installation instructions and guidelines must be followed.
7. Installation, operation, and maintenance instructions in the language of the user's country are the responsibility of the machine builder.

## CHAPTER 2: SAFETY-RELATED GUIDELINES

### Safety Related Guidelines for Users of GE Fanuc PLC Products to be Installed in the European Union

#### 2.1 Introduction

This chapter provides a description of safety-related guidelines for installation of PLC systems. It is assumed that personnel who install, operate, and maintain automation systems, which include GE Fanuc products are trained and qualified to perform those functions. This chapter specifically provides safety-related guidelines for products to be installed in the European Union.

##### a. General

GE Fanuc product manuals provide information required for the intended use of GE Fanuc products. The product manuals are written for technically qualified personnel such as engineers, programmers or maintenance specialists who have been specifically trained and are experienced in the field of automation control. Such personnel must possess the knowledge to correctly interpret and apply the safety guidelines provided in GE Fanuc product manuals. Should you require further information or face special problems that have not been dealt with in sufficient detail in the product manuals, please contact your local GE Fanuc sales or service office or a GE Fanuc authorized distributor.

##### b. Qualified Personnel

Only qualified personnel shall be allowed to specify, apply, install, operate, maintain or perform any other function related to the products described in the product manuals. Examples of such qualified persons are defined as follows:

1. System application and design engineers who are familiar with the safety concepts of automation equipment.
2. Installation, startup, and service personnel who are trained to install and maintain such automation equipment.
3. Operating personnel trained to operate automation equipment and trained on the specific safety issues and requirements of the particular equipment.

##### c. Proper Usage:

The equipment/system or the system components can only be used as described in the product manuals. GE Fanuc PLC products have been developed, manufactured, and tested, and the documentation has been compiled in keeping with the relevant safety standards. Handling instructions and safety guidelines described for planning, installation, proper operation and maintenance must be followed to ensure safe application and use of the products.

**d. Guidelines for the Application Planning and Installation of the Product:**

GE Fanuc PLC products generally form a part of larger systems or installations. These guidelines are intended to help integrate GE Fanuc PLC products into systems and installations without constituting a source of danger. The following precautions must be followed:

1. Compliance with EN292-1 and EN292-2 (Safety of Machinery) as well as EN60204/IEC204 (Electrical Equipment of Industrial Machines) must be observed during the design phase.
2. Opening the housing or the protective cover exposes certain parts of this equipment/system, which could have a dangerously high voltage level.
3. Only qualified personnel should be allowed access to this equipment/system.
4. These persons must be knowledgeable of potential sources of danger and maintenance measures as set out in the product manuals.
5. Strictly adhere to applicable safety and accident prevention rules and regulations.
6. A suitable isolating switch or fuses must be provided in the building wiring system. The equipment must be connected to a protective ground (PE) conductor.
7. For equipment or systems with a fixed connecting cable but no isolating switch which disconnects all poles, a power socket with the grounding pin must be installed.
8. Before switching on the equipment, make sure that the voltage range setting on the equipment corresponds to the local power system voltage.
9. Fluctuations or deviations of the new power supply voltage from the rated value must not exceed the tolerances specified in the technical specifications. Otherwise, functional failures or dangerous conditions can occur in the electronic modules/equipment.
10. Emergency tripping devices in accordance with EN60204/IEC204 must be effective in all operating modes of the automation equipment. Resetting the emergency off device must not result in any uncontrolled or undefined restart of the equipment.
11. Automation equipment and its operating elements must be installed in such a manner as to prevent unintentional operation.
12. Suitable measurements must be taken to make sure that operating sequences interrupted by a voltage dip or power supply failure resume proper operation when the power supply is restored. Care must be taken to ensure that dangerous operating conditions do not occur even momentarily. If necessary, the equipment must be forced into the "emergency off" state.
13. Negative logic Input and Output Modules cannot be used. (Exception: With safety agency approval (such as TÜV on GMR Systems), these devices may be used in safety system "H" configurations).

14. Cable shielding and grounding are the responsibility of the machine builder. Installation instructions and guidelines must be followed.
15. Install the power supply and signal cables in such a manner as to prevent inductive and capacitive interference voltages from affecting the automation functions.
16. Measures must be taken when interfacing the inputs and outputs of the automation equipment to prevent an undefined state from being assumed in the case of a wire break in the signal lines.



NOTES

## APPENDIX A: PRODUCT AGENCY APPROVALS, STANDARDS, & GENERAL SPECIFICATIONS

### 1 Introduction

This information applies to GE Fanuc products.

Table 1 – Agency Approvals Overview <sup>1</sup>		
Standard/Directive	Approval/Symbol	Comments
Industrial Control Equipment [Safety]	UL508	Certification by certified test facility
Process Control Equipment [Safety]	C-UL	Certification by certified test facility
Hazardous Locations [Safety] Class I, Div II, A, B, C, D	UL1604 with C-UL	Certification by certified test facility
European EMC Directive	CE Mark	Self-certification in accordance with applicable CE directives

Table 2 – Standards Overview <sup>2,4</sup>		
Parameters	Approval/Symbol	Conditions
Operating Temperature <sup>3</sup>		0°C to 60°C
Storage Temperature		-40°C to +85°C
Humidity		5% to 95%, non-condensing
Enclosure Protection	IEC529	Steel cabinet per IP54: Protection from dust and splashing water
EMC Emissions EN50081-2: 1995 Generic Emissions for Heavy Industrial Environment		
Radiated, Conducted	CISPR11 EN55022	Class A

<b>Table 3 – EMC Immunity (Applies to CE Marked Modules)</b>		
<b>EMC Immunity EN50082-2: 1995 Generic Immunity for Heavy Industrial Environment</b>		
<b>Test</b>	<b>Standard</b>	<b>Conditions</b>
Electrostatic Discharge	EN61000-4-2:1995	8KV Air Discharge, 4KV Contact Discharge
Radiated RF	ENV50140:1995	10Vrms/m, 80Mhz to 1000Mhz, modulated
Fast Transient Burst	EN61000-4-4:1995	2KV: power supplies, 1KV: I/O, communications
Surge Withstand	EN61000-4-5:1995	2KV power, 1KV to shields
Conducted RF	ENV50141:1995	10V, 150Khz to 80Mhz injection for communication cables >30m
Damped Oscillator Wave	EN61000-4-12	2.5Kv Comm. mode 2.5Kv Diff. mode

<b>Table 4 – Power Supply</b>		
<b>Test</b>	<b>Standard</b>	<b>Condition</b>
Input Dips, Variations	EN61000-4-11:1995	During Operation: Dip to 30% and 100%, Variation for AC $\pm 10\%$ , Variation of DC $\pm 20\%$