

GFK-1631
New In Stock!
GE Fanuc Manuals

<http://www.pdfsupply.com/automation/ge-fanuc-manuals/ocs/GFK-1631>

OCS
1-919-535-3180

Control Station Hardware Manual

www.pdfsupply.com

Email: sales@pdfsupply.com

GFK-1631
New In Stock!
~~GE Fanuc~~ Manuals

<http://www.pdfsupply.com/automation/ge-fanuc-manuals/ocs/GFK-1631>

OCS
1-919-535-3180

Control Station Hardware Manual

www.pdfsupply.com

Email: sales@pdfsupply.com



User Manual for
IC300OCS100 / OCS110, IC300OCS200 / OCS210,
IC300OCS250, IC300RCS210 / RCS250,
IC300FOX100 / FOX110, SFX100,
IC300FOX104 / FOX404

Control Station Hardware Manual

25 June 2002

GFK-1631C

Warnings, Cautions, and Notes as Used in this Publication

Warning

Warning notices are used in this publication to emphasize that hazardous voltages, currents, temperatures or other conditions that could cause personal injury exist in this equipment or may be associated with its use.

In situations where inattention could cause either personal injury or damage to equipment, a Warning notice is used.

Caution

Caution notices are used where equipment might be damaged if care is not taken.

Note

Notes merely call attention to information that is especially significant to understanding and operating the equipment.

This document is based on information available at the time of its publication. While efforts have been made to be accurate, the information contained herein does not purport to cover all details or variations in hardware or software, nor to provide for every possible contingency in connection with installation, operation, or maintenance. Features may be described herein which are not present in all hardware and software systems. GE Fanuc Automation assumes no obligation of notice to holders of this document with respect to changes subsequently made.

GE Fanuc Automation makes no representations or warranty, expressed, implied, or statutory with respect to, and assumes no responsibility for the accuracy, completeness, sufficiency, or usefulness of the information contained herein. No warranties of merchantability or fitness for purpose shall apply.

The following are trademarks of GE Fanuc Automation North America, Inc.

Alarm Master	CIMSTAR	Helpmate	PROMACRO	Series Six
CIMPLICITY	GENet	Logicmaster	Series One	Series 90
CIMPLICITY 90 – ADS	Genius	ModelMaster	Series Three	VuMaster
CIMPLICITY Power TRAC	Genius PowerTRAC	ProLoop	Series Five	Workmaster

The following are trademarks of Horner APG, LLC.

Cscape SmartStack CsCAN

The following are trademarks of the Open DeviceNet Vendor Association (OVDA), Inc.
DeviceNet

Revisions to this manual

1. Revised Section 1.3.3, 3.3.1, 4.2, and 5.2 to include the use of Fiber Optics and the expansion of up to 20 SmartStack I/O Modules can be connected to an OCS or RCS using five Fiber Optic Bases (FOX104 / 404), which each contain four I/O slots. If an expanded I/O connection is desired, the SmartStack FOX100 / 110 module must occupy the local OCS110 / 210/ 250 / or RCS250 Slot 1 position.
2. Added Section 1.7 to include the Fiber Optic Extension System (FOX104 / 404) and the SmartStack Fiber Optic Expansion Module (FOX100 / 110).
3. Added Section 1.8 to cover NEMA Rated Products; also added Section 2.2, item F. Revised Table 1.1. Added Torque specifications to Section 3.3.1, item 4.
4. Deleted Section 2.32, item b. Re-numbered and revised Section 2.3.2, items b, c, d, and e.
5. Revised 2.3.5, item c.
6. Revised battery replacement procedures in Section 3.5 (OCS x00) and Section 4.3 (Section 3.5).
7. Added battery replacement procedures in Section 5.5 (RCS210).
8. Added a new Section 6.4: Remote Screen / Keypad (Using Remote Text Terminal and Status Bar) and renumbered the chapter.
9. Revised Section 6.7: System Menu Options: I/O Slots. Removed Char Sets option.
10. Revised Section 7.4 Operations.
11. Added New Chapter 9: Fiber Optic Extension System (FOX104 / 404).
12. Added New Chapter 10: SmartStack Fiber Optic Expansion Module (FOX100 / 110). Includes the SFX100.

Table of Contents

CHAPTER 1: INTRODUCTION..... 9

 1.1 Scope..... 9

 1.1.1 Products Covered in this Manual 9

 1.1.2 Additional References 9

 1.2 Operator Control Station (OCS) / Remote Control Station (RCS)..... 9

 1.2.1 OCS1XX / 2XX Product Description..... 9

 1.2.2 OCS250 Product Description 11

 1.2.3 RCS Product Description..... 11

 1.2.4 Cscape Software IC300OSW232 12

 1.2.5 OCS / RCS Specifications 12

 1.3 OCS / RCS Resources 13

 1.3.1 Overview..... 13

 1.3.2 Resource Limits..... 14

 1.3.3 Resource Definitions 15

 1.4 SmartStack Product Description 20

 1.5 Relationship of SmartStack Modules, OCS, RCS and FOX Products 20

 1.6 Differences Between OCS and RCS 21

 1.7 Fiber Optic (FOX) Products Description 21

 1.9 Technical Support 22

CHAPTER 2: INSTALLATION 23

 2.1 General..... 23

 2.2 Factors Affecting Panel Layout Design and Clearances 23

 2.2.1 Panel Layout Design and Clearance Checklist:..... 25

 2.3 Ports, Connectors and Wiring 26

 2.3.1 Primary Power Port 26

 2.3.2 CAN / DeviceNet Network Port and Wiring 26

 2.3.3 RS-232 Programming Port and Wiring 29

 2.3.4 RS-485 Connector (Graphic OCS250 only) 31

 2.3.5 Modem Setup 31

 2.4 Installing and Removing a SmartStack Module (Shown with the OCS) 33

 2.5 Selecting DeviceNet Network (Firmware Update Wizard) 34

 2.6 LEDs (OCS / Graphic OCS / RCS Models)..... 34

 2.6.1 LEDs for OCS / RCS 34

 2.6.2 LEDs for Graphic OCS (OCS250) 36

CHAPTER 3: OCS1XX AND OCS2XX 37

 3.1 General..... 37

 3.2 Mounting Orientation 37

 3.3 Mounting Requirements 38

 3.3.1 Mounting Procedures 38

 3.3.2 OCS and SmartStack Dimensions and Panel Cut-outs 38

 3.4 OCS Ports, Connectors, and Wiring..... 40

 3.4.1 Power, Network, and Programming Ports 40

 3.5 Battery Replacement for the OCS1XX / 2XX (HE500BAT005) 41

CHAPTER 4: GRAPHIC OCS (OCS250) 43

 4.1 General..... 43

 4.2 Mounting Orientation 43

 4.3 Battery Replacement for the Graphic OCS (OCS250) (HE500BAT005) 47

CHAPTER 5: REMOTE CONTROL STATION (RCS) 49

 5.1 General..... 49

 5.2 Mounting Orientation 49

 5.3 Mounting Instructions 50

 5.4 RCS Optional Mounting Bracket (HE800ACC210) 51

 5.5 Dimensions and Panel Cut-Out 52

5.6	Connectors	53
5.5	Battery Replacement for the RCS (HE500BAT005)	53
CHAPTER 6: OCS / RCS CONFIGURATION (SYSTEM MENU).....		55
6.1	General.....	55
6.2	Navigating Through the System Menu	55
6.3	Editing System Menu Screen Fields.....	55
6.4	Remote Screen / Keypad (Using Remote Text Terminal and Status Bar).....	56
6.5	Initial System Menu Screens and Self-Test	56
6.6	Entering the System Menu	56
6.7	Setting RCS Network ID.....	61
CHAPTER 7: KEYPAD AND SCREEN.....		65
7.1	Remote Screen and Keypad Capability.....	65
7.1.1	Remote Text Terminal.....	65
7.1.2	Cscape Status Bar	65
7.1.3	Establishing Communications using the Remote Text Terminal.....	66
7.2	OCS1XX Description	66
7.3	OCS2XX Description	67
7.4	Graphic OCS250 Description	68
7.5	User Screens	70
7.5.1	Cursor Types (Does Not Apply to Graphic OCS250)	70
CHAPTER 8: SMARTSTACK CONFIGURATION		71
8.1	General.....	71
8.2	Preliminary Configuration Procedures	71
CHAPTER 9: FIBER OPTIC EXTENSION SYSTEM (FOX104 / FOX404).....		77
9.1	General.....	77
9.2	FOX104 / 404 Specifications	77
9.3	Installation	77
9.3.1	Mounting Orientation.....	77
9.3.2	Mounting Instructions	78
9.3.2	Dimensions and Hole Pattern	79
9.4	Ports, Connectors, and Wiring	80
9.5	Base ID Switches	81
9.6	FOX104 / FOX404 LEDs.....	82
9.7	Example Setups	82
CHAPTER 10: SMARTSTACK FIBER OPTIC EXPANSION MODULE (FOX100 / 110) AND FIBER MEDIA CONVERTER (SFX100)		85
10.1	General	85
10.2	FOX Specifications and Limitations Error! Bookmark not defined.	85
10.3	Connectors and Slot Positions	86
10.4	LEDs.....	86
10.5	Example Setups.....	87
10.6	Fiber Media Converter (IC300SFX100).....	90
10.6.1	Using FOX100 with SFX	90
10.6.2	Using FOX110 with SFX	91
APPENDIX A: NETWORKS.....		93
APPENDIX B: DISTRIBUTED CONTROL SYSTEMS (DCS)		99
INDEX		101

CHAPTER 1: INTRODUCTION

1.1 Scope

1.1.1 Products Covered in this Manual

The Control Station Hardware User Manual provides information about the Operator Control Station (IC300OCS1xx and IC300OCS2xx), the Graphical Operator Control Station (IC300OCS250), the Remote Control Station (IC300RCS2xx) and the SmartStack I/O Option Modules.

- a. The specifications, installation, and configuration procedures of the Operator Control Station (OCS) and the Remote Control Station (RCS) are covered in detail in this user manual. Information is also provided for the use of the products in CsCAN or DeviceNet Networks.
- b. Because there is a wide variety of SmartStack Modules, the focus of the Control Station User Manual is to provide *general* installation and configuration data, which is common to *all* SmartStack Modules. To obtain specific information regarding SmartStack Modules, refer to the individual data sheets created for each module in the SmartStack Supplement. (See next section.)

1.1.2 Additional References

For further information regarding products covered in this manual, refer to the following references:

- a. *SmartStack Modules User Manual* (GFK-1601) - Contains individual data sheets for each module and covers specifications, wiring, and configuration.
- b. *DeviceNet[™] Implementation Using Control Station Modules* (GFK-1763) - Covers the implementation of Control Station products in a DeviceNet network.
- c. *Cscape Reference Manual* (GFK-1722) – Topics in this manual have been specifically selected to assist the user through the programming process. It also covers procedures for creating graphics using the Graphic OCS.
- d. *SmartStack Ethernet Module User Manual* (GFK-1784) – Covers the SmartStack Ethernet Module for use in Ethernet networks.

1.2 Operator Control Station (OCS) / Remote Control Station (RCS)

1.2.1 OCS1XX / 2XX Product Description

The Operator Control Station (OCS1XX & OCS2XX) provides controller, networking, I/O and operator interface capabilities in one unit. The OCS can be used in CsCAN or DeviceNet networks. To use the OCS in a DeviceNet network, a DeviceNet file can be downloaded from Cscape's Firmware Update Wizard. (Refer to Section 2.5.)

Operator Control Stations have Serial and CAN (Controller Area Network) communication abilities. The units contain a standard 9-pin RS-232 port for programming/debugging, monitoring and network administration from an IBM-compatible PC. The OCS1XX and OCS2XX CAN features include CsCAN (pronounced "Sea-scan") peer-to-peer network. CAN-based network hardware is used in the controllers because of CAN's automatic error detection, ease of configuration, low-cost of design and implementation and ability to operate in harsh environments. Networking abilities are built-in to the OCS and require no external or additional modules. When several Operator Control Stations are networked together to achieve a specific purpose, the system acts like a large parallel-processing controller.

The OCS combines several desirable functions in one compact package. Each unit is a highly integrated operator interface and controller with expandable I/O and networking capabilities. The OCS1XX features a 2x20 LCD, 17 keys and fieldbus communications. The OCS2XX features a 4x20 LCD, 32 keys and fieldbus communications. Both devices have standard features consisting of the following:

- 24 VDC powered
- SmartStack™ I/O Expansion
- RS-232 Programming Port
- Integrated Bezel
- Removable Keypad Inserts
- Real-Time Clock
- Flash Memory for easy field upgrades

Note: The OCS2XX has a larger keypad than the OCS1XX.

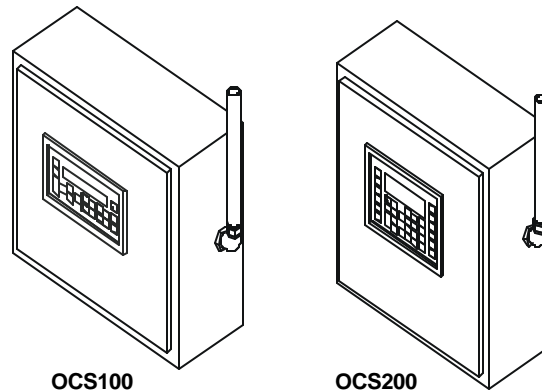

Figure 1.1 - Front View of OCS100 / OCS200

The OCS product line features the ability to pass through programming commands. When attached to an OCS serial port, a programming package (i.e., Cscape), can access other OCS units connected to a CsCAN network by passing the programming command through the serial port to the network port. One Cscape package (connected to one OCS unit) can program all OCS units on the CsCAN network.

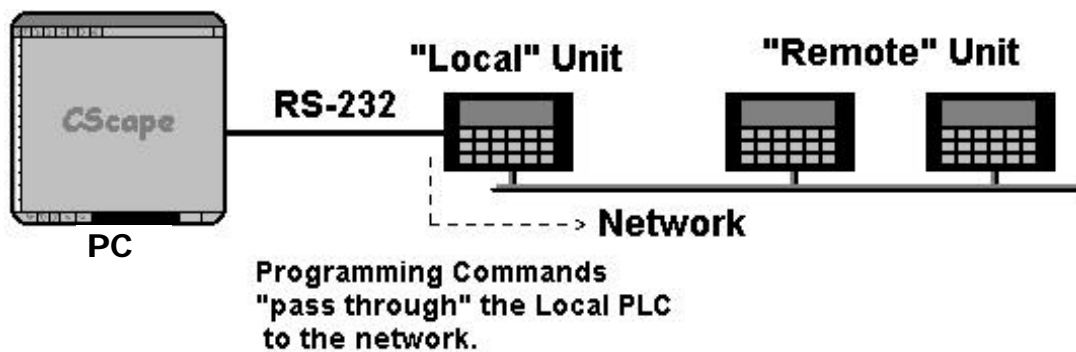
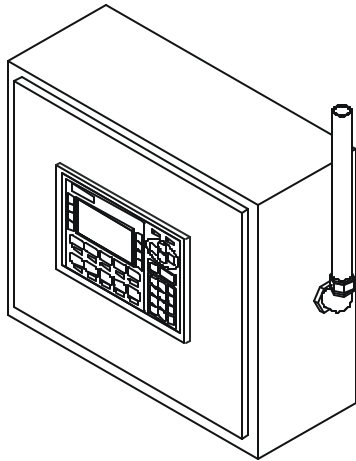

Figure 1.2 – Pass-Through Function
(Available in CsCAN Networks Only)

After making a physical serial connection to one OCS, the user must indicate which node is to be connected (called the TARGET). After that, Cscape and the OCS automatically provide the pass through connection.

1.2.2 OCS250 Product Description

In addition to the features listed in Section 1.2.1, the OCS250 has graphical capabilities.



**Figure 1.3 –Orientation of Graphic OCS
(Shown in Panel Box)**

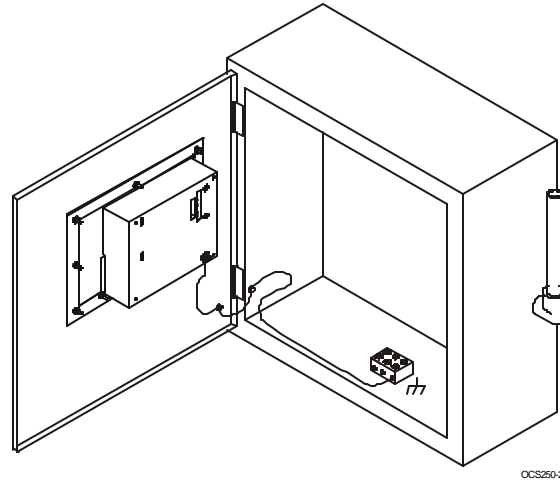

**Figure 1.4 –Back View of Graphic OCS
(Shown in Panel Box)**

1.2.3 RCS Product Description

The RCS is similar to an OCS in that it combines local I/O (analog and digital), networking, and a controller into a single product. Unlike the OCS, the RCS is not equipped with a display and keypad. Although the RCS does not have a local operator interface, it does support a remote operator interface through a PC connected to the RCS unit's serial port or built-in network. The RCS is designed for back-plate mounting. (The OCS is mounted on a panel door.) The RCS can be used in CsCAN or DeviceNet networks. To use the RCS in a DeviceNet network, a DeviceNet file can be downloaded from Cscape's Firmware Update Wizard. (Refer to Section 2.5.)

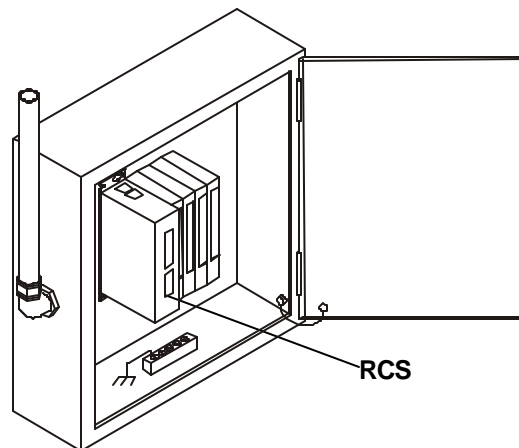

Figure 1.5 - RCS in Panel Box (Shown with Four SmartStack Modules)

1.2.4 Cscape Software IC300OSW232

Cscape Software (pronounced “Sea-scape”) is used with the OCS and RCS products. Cscape stands for **Control Station Central Application Programming Environment**. The Windows-based software package is easy to use and aids in the integration of a CAN-based Distributed Control System. The program is used for configuring controllers and SmartStack I/O Modules. Cscape is also used for programming OCS ladder logic, programming user displays for the OCS, configuring the network for global digital and analog data, setting system-wide security and monitoring controllers in the system. Provided there is **one serial connection** to one node on the network (i.e., CsCAN Network), the operator has control over the entire system. The operator can upload, download, monitor and debug to any node on the network.

1.2.5 OCS / RCS Specifications

Table 1.1 – Specifications	
OCS 1xx,2xx,250 and RCS2xx	
Humidity	5% to 95% non-condensing
NEMA Standard	NEMA 4, 12
(Note: Does <u>NOT</u> apply to RCS2xx)	(Note: UL NEMA 4,4X, 12 available as an option for OCS100, OCS110, OCS200, OCS210. This option is highly recommended for washdown environments.)
Primary Power Range*	10-30VDC
Ladder Execution	
Typical Execution Speed	0.7 ms. per 1K of boolean logic.
CAN Power Range	12 – 25 VDC
CAN Power Current	75mA maximum
Primary Serial	Standard 9 pin RS-232 for programming, monitoring, and network administration from a IBM compatible PC
Secondary Serial (OCS250 only)	RS-485 or RS-232 – Application Communication Port
CAN	CsCAN Network / DeviceNet
Input / Output	Local (All Modules): Maximum of four (4) SmartStack Modules per OCS Remote (OCS110 / 210/ 250 / or RCS250 Modules): In addition to 4 local I/O modules, up to 20 remote SmartStack I/O Modules can be connected to an OCS or RCS using five Fiber Optic Bases, which each contain four I/O slots.
Keypad (For all models below)	Faceplate made of Autotex® polyester by Autotype®. The material is resistant to most corrosive substances found in industrial environments. The material also holds up well in most industrial conditions. If used outdoors, the material can yellow or crack.
UL (except RCS250)	Class I, Groups A, B, C, D, Division 2
CE (except RCS250)	Yes
OCS 1xx	
Operating Temperature	0°C to +60°C **
Typical Power Draw *	160mA @ 24VDC
Inrush Current *	200mA @ 24VDC for 70mS
Height	5.07" (128.78 mm)
Width	9.00" (228.60 mm)
Mounting Depth	2.00" (50.80 mm)
User Keys	17
Keypad	10 user-programmable keys + Shift, Esc, Enter and 4 direction keys
Display	2x20 LCD w/backlight; 4.84w x 8.06h mm characters

OCS 2xx	
Operating Temperature	0°C to +60°C **
Typical Power Draw *	180mA @ 24VDC
Inrush Current *	270mA @ 24VDC for 1S
Height	7.13" (181.10 mm)
Width	9.00" (228.60 mm)
Mounting Depth	2.00" (50.80 mm)
User Keys	32
Keypad	12 user-programmable keys + Shift, Esc, Enter, 4 direction keys and a full numeric keypad
Display	4x20 LCD w/backlight ; 4.84w x 8.06h mm characters
OCS250	
Operating Temperature	0°C to +50°C
Typical Power Draw *	350mA @ 24VDC
Inrush Current *	800mA @24VDC for 50mS.
Height	7 7/8" (200.02 mm)
Width	11 1/8" (282.57 mm)
Mounting Depth	5 3/16" (131.76 mm)
User Keys	10 user-programmable keys + Esc, Enter, 4 direction keys and a full numeric keypad + 8 soft keys.
Keypad	36
Display	240 x 128 Graphic LCD w / backlight
RCS2xx	
Operating Temperature	0°C to +60°C
Typical Power Draw *	150mA @ 24VDC
Inrush Current*	1A @ 24VDC for 8mS
Height	7.00" (177.8 mm)
Width	1.75" (44.45 mm)
Mounting Depth	4.00" (101.60 mm)
Keypad	Although the RCS does <u>not</u> have a local operator interface, it supports a remote operator interface through a PC connected to the RCS unit's built-in network. 32-Key (Remote Only)
Display	Although the RCS does <u>not</u> have local display, it supports a remote operator interface through a PC connected to the RCS unit's built-in network.
* These specifications are for OCS, Graphical OCS, and RCS products without any SmartStack I/O Modules attached. The specifications for the SmartStack Modules can be found in the applicable SmartStack Data Sheets.	
** Although the OCS1XX and OCS2XX withstands the temperature range of 0°C to +60°C, such temperatures may decrease the life of the display. The recommended rating is 0°C to +50°C.	

1.3 OCS / RCS Resources

1.3.1 Overview

This section defines the resource limits of the OCS1XX, OCS2XX, OCS250, and the RCS2xx.

An OCS combines operator interface (display and keypad), local I/O (analog and digital), networking, and controller, into a single product. In addition, the OCS250 has graphical capabilities. An RCS is a repackaged OCS, without the operator interface, designed for back-plate mounting. Although the RCS does not have a local operator interface, it supports a remote operator interface through a PC connected to the RCS unit's built-in network or serial port.

The controller portion of the OCS/RCS products is programmed in ladder logic via the Windows-based Cscape (Control Station Central Application Programming Environment) package. Each OCS or RCS product provides a set of resources for use by the ladder logic control program as indicated in Table 1.2.

1.3.2 Resource Limits

The following table shows the resources available in the OCS100, OCS110, OCS200, OCS210, OCS250, RCS210 and RCS250 products. Note that although each register type inherently consists of either 1-bit or 16-bit registers, all registers can be accessed via User Screens and/or Ladder Code as 1, 8, 16 or 32-bit values or as ASCII character strings.

Table 1.2 – OCS/RCS Resource Limits							
Resource	OCS100	OCS110	OCS200	OCS210	OCS250	RCS210	RCS250
%S	8						
%SR	192						
%T	2048						
%M	2048						
%R	2048	9999	2048	9999	9999	2048	9999
%K	10	10	12	12	10	12	12
%D	200	200	200	200	300	200	200
%I	2048						
%Q	2048						
%AI	512						
%AQ	512						
%IG	64 / 0						
%QG	64 / 0						
%AIG	32 / 16						
%AQG	32 / 16						
Network Port	CsCAN / DeviceNet						
Controllers Per Network	253 / 64						
SmartStack I/O Modules	4 Slots	4 Slots (23 with FOX)	4 Slots	4 Slots (23 with FOX)	4 Slots (23 with FOX)	4 Slots	4 Slots (23 with FOX)
Keypad	17 Keys	17 Keys	32 Keys	32 Keys	36 Keys	32 Keys (Remote Only)	32 Keys (Remote Only)
Display	2x20 Chars (Text LCD)	2x20 Chars (Text LCD)	4x20 Chars (Text LCD)	4x20 Chars (Text LCD)	128x240 Pixels (Graphics LCD)	4x20 Chars (Remote Only)	4x20 Chars (Remote Only)
Screen Memory	64K	128K	64K	128K	2M	64K	128K
User Screens	200	200	200	200	300	200	200
Data Fields Per User Screen	16	16	16	16	50	16	16
Text Tables	200						
Items Per Text Table	20	20	20	20	Unlimited	20	20
Ladder Code	64K	128K	64K	128K	128K	64K	128K

1.3.3 Resource Definitions

This section defines the resources listed in Table 1.2.

System Registers

System Registers (%S and %SR) are used to store general OCS or RCS status information. This information is used internally, and is also available to the operator via the System Menu, using the Control Station's display and keypad. The System Registers are also available for User Screens and can be accessed by Ladder Code.

a. %S Registers

%S Registers are 1-bit memory locations, containing system status information, implemented as shown in Table 1.3.

Register	Name	Description
%S1	FST_SCN	On during first scan after entering RUN mode
%S2	NET_OK	On if Network is functioning properly
%S3	T_10MS	On for 5 mS; Off for 5 mS
%S4	T_100MS	On for 50 mS; Off for 50 mS
%S5	T_SEC	On for 500 mS; Off for 500 mS
%S6	IO_OK	On if SmartStack I/O is configured properly
%S7	ALW_ON	Always On
%S8	ALW_OFF	Always Off

b. %SR Registers

%SR Registers are 16-bit memory locations, containing system status information, implemented as shown in Table 1.4.

Note: Where 2 %SRs are combined to make a 32-bit value, the lower-numbered %SR is the low word, while the higher-numbered %SR is the high word.

Register	Name	Description	Min	Max
%SR1	USER_SCR	Current User Screen Number (0=none)	0	300
%SR2	ALRM_SCR	Current Alarm Screen Number (0=none)	0	300
%SR3	SYS_SCR	Current System Screen Number (0=none)	0	11
%SR4	SELF_TEST	Bit-Mapped Self-Test Result	0	65535
%SR5	CS_MODE	Control Station Mode (0=Idle, 1=Do I/O, 2=Run)	0	2
%SR6	SCAN_RATE	Average Scan Rate (in tenths of mS)	-	1000
%SR7	MIN_RATE	Minimum Scan Rate (in tenths of mS)	-	1000
%SR8	MAX_RATE	Maximum Scan Rate (in tenths of mS)	-	1000
%SR9-10	EDIT_BUF	Data Field Edit Buffer	0	2 ³² -1
%SR11-12	LADDER_SIZE	Ladder Code Size	2	64K
%SR13-14	UTXT_SIZE	User Text Screen Table Size	4	64K
%SR15-16	Reserved	-	-	-
%SR17-18	IO_SIZE	I/O Configuration Table Size	16	64K
%SR19-20	NET_SIZE	Network Configuration Table Size	34	32K
%SR21-22	SD_SIZE	Security Data Table Size	-	-
%SR23	LADDER_CRC	Ladder Code CRC	0	65535
%SR24	UTXT_CRC	User Text Screen Table CRC	0	65535

Table 1.4 - %SR Registers				
Register	Name	Description	Min	Max
%SR25	Reserved	-	-	-
%SR26	IO_CRC	I/O Configuration Table CRC	0	65535
%SR27	NET_CRC	Network Configuration Table CRC	0	65535
%SR28	SD_CRC	Security Data Table CRC	0	65535
%SR29	NET_ID	This Station's Primary Network ID (CsCAN)	1	253
		This Station's Primary Network ID (DeviceNet)	0	63
%SR30	NET_BAUD	Network Baud Rate (CsCAN) (0=125KB; 1=250KB; 2=500KB; 3=1MB)	0	3
		Network Baud Rate (DeviceNet) (0=125KB; 1=250KB; 2=500KB)	0	2
%SR31	NET_MODE	Network Mode (0=Network Not Required; 1=Network Required; 2=Reserved; 3=Network Required and Optimized)	0	3
%SR32	LCD_CONT	LCD Display Contrast Setting	0	255
%SR33	FKEY_MODE	Function Key Mode (0=Momentary; 1=Toggle)	0	1
%SR34	SERIAL_PROT	RS232 Serial Protocol Mode (0=Firmware Update (RISM); 1=CsCAN; 2=Generic (Ladder- Controlled); 3=Modbus RTU; 4=Modbus ASCII)	0	4
%SR35-36	SERIAL_NUM	This Station's 32-bit Serial Number	0	2 ³² -1
%SR37	MODEL_NUM	This Station's Binary Model Number	0	65535
%SR38	ENG_REV	Main CPU Engine Firmware Rev Number x 100	0000	9999
%SR39	BIOS_REV	Main CPU BIOS Firmware Rev Number x 100	0000	9999
%SR40	FPGA_REV	FPGA Image Rev Number x 10	000	255
%SR41	LCD_COLS	LCD Text Display Number of Columns	20	20
		LCD Graphics Display Number of Columns	240	240
%SR42	LCD_ROWS	LCD Text Display Number of Rows	2	4
		LCD Graphics Display Number of Rows	128	128
%SR43	KEY_TYPE	Keypad Type (0=16 Keys; 1=17 Keys; 2=32 Keys; 3=36 Keys)	0	3
%SR44	RTC_SEC	Real-Time-Clock Second	0	59
%SR45	RTC_MIN	Real-Time-Clock Minute	0	59
%SR46	RTC_HOUR	Real-Time-Clock Hour	0	23
%SR47	RTC_DATE	Real-Time-Clock Date	1	31
%SR48	RTC_MON	Real-Time-Clock Month	1	12
%SR49	RTC_YEAR	Real-Time-Clock Year	1996	2095
%SR50	RTC_DAY	Real-Time-Clock Day (1=Sunday)	1	7
%SR51	NET_CNT	Network Error Count	0	65535
%SR52	WDOG_CNT	Watchdog-Tripped Error Count	0	65535
%SR53-54	BAD_LADDER	Bad Ladder Code Error Index	0	65534
%SR55	F_SELF_TEST	Filtered Bit-Mapped Self-Test Result	0	65535
%SR56	LAST_KEY	Key Code of Last Key Press or Release	0	255
%SR57	BAK_LITE	LCD Backlight On/Off Switch (0=Off; 1=On)	0	1
%SR58	USER_LEDS	User LED Control / Status	0	65535
%SR59	S_ENG_REV	Slave CPU Engine Firmware Rev Number x 100	0000	9999
%SR60	S_BIOS_REV	Slave CPU BIOS Firmware Rev Number x 100	0000	9999
%SR61	NUM_IDS	This Station's Number of Network IDs (CsCAN)	1	253
		This Station's Number of Network IDs (DeviceNet)	1	1
%SR62-64	Reserved	-	-	-
%SR65-76	SS_INFO_1	SmartStack I/O Module #1 Information Structure	-	-
%SR77-88	SS_INFO_2	SmartStack I/O Module #2 Information Structure	-	-
%SR89-100	SS_INFO_3	SmartStack I/O Module #3 Information Structure	-	-
%SR101-112	SS_INFO_4	SmartStack I/O Module #4 Information Structure	-	-
%SR113-114	GOBJ_SIZE	Graphics Object Table Size	8	128K

Register	Name	Description	Min	Max
%SR115-116	GSTR_SIZE	Graphics String Table Size	8	128K
%SR117-118	GBMP_SIZE	Graphics Bitmap Table Size	8	256K
%SR119-120	GTXN_SIZE	Graphics Text Table Size	8	128K
%SR121-122	GFNT_SIZE	Graphics Font Table Size	8	128K
%SR123-124	Reserved	-	-	-
%SR125	GOBJ_CRC	Graphics Object Table CRC	0	65535
%SR126	GSTR_CRC	Graphics String Table CRC	0	65535
%SR127	GBMP_CRC	Graphics Bitmap Table CRC	0	65535
%SR128	GTXN_CRC	Graphics Text Table CRC	0	65535
%SR129	GFNT_CRC	Graphics Font Table CRC	0	65535
%SR130-192	Reserved	-	-	-

User Registers

User Registers (%T, %M and %R) are used to store application-specific OCS or RCS data. This data can be accessed via User Screens and/or by Ladder Code.

a. %T Register

A %T Register is a non-retentive 1-bit memory location used to store application-specific state information.

b. %M Registers

A %M Register is a retentive 1-bit memory location used to store application-specific state information.

c. %R Registers

A %R Register is a retentive 16-bit memory location used to store application-specific values.

HMI Registers

HMI Registers (%K and %D) give the user access to the OCS or RCS keypad and display.

The MiniOCS, OCS1XX and OCS2XX have membrane keypads and text-based LCD displays, allowing the operator to enter and display general and application-specific information. This same information can be entered and displayed via a remote PC, using Cscape's Remote Display Terminal function, if the PC is connected as a CsCAN Host device. The RCS does not have a local keypad or display, but it still supports Cscape's Remote Display Terminal function. The OCS250 has a membrane keypad and a graphics-based LCD display, but it does not yet support the Cscape Remote Display Terminal function.

a. %K Registers

A %K Register is a non-retentive 1-bit memory location (contact), used to store the state of a function key on the Control Station's keypad. If the function keys are set for momentary mode, a function key's associated %K register will be ON as long as the function key is pressed. If the function keys are set for toggle mode, a function key's associated %K register will toggle each time the function key is pressed.

b. %D Registers

A %D Register is a non-retentive 1-bit memory location (coil), which can be turned ON by Ladder Code to cause the corresponding User or Alarm Screen to be displayed.

c. User Screens

A User Screen is a combination of fixed text or graphics, along with variable Data Fields (called Graphics Objects in the OCS250), which together fill the LCD display screen. These screens are defined via Cscape dialogs and are then downloaded and stored into the Control Station's Flash memory. User Screens can be selected for display by operator entries on the keypad or by Ladder Code.

d. Data Fields

A Data Field is an area on a User Screen where variable data is displayed and edited. The source data for a Data Field can be any of the Control Station's Register resources as defined above. The field size and display format is programmable via Cscape dialogs.

e. Text Tables

A Text Table is a list of Text Items, which can be used in a Data Field, to display descriptive words and phrases to describe the value of a Register, instead of displaying numeric values. A simple example of this, would allow the strings "OFF" and "ON" to be displayed, instead of 0 and 1, to describe the state of the %I4 digital input. The maximum number of Text Tables and Text Items per Text Table is shown in Table 1, but the number can be further limited by overall User Screen memory usage.

SmartStack I/O Registers

SmartStack I/O Registers (%I, %Q, %AI and %AQ) give the user access to the SmartStack I/O Module data. This data can be accessed via User Screens and/or by Ladder Code.

a. %I Registers

A %I Register is a 1-bit memory location, which is normally used to store the state of one of the digital inputs associated with a SmartStack I/O module. When used in this way, %I registers are non-retentive. All extra %I registers, which are not associated with SmartStack inputs, are retentive, and can be used just like %M registers.

b. %Q Registers

A %Q Register is a non-retentive 1-bit memory location, which is normally used to store the state of one of the digital outputs associated with a SmartStack I/O module.

c. %AI Registers

A %AI Register is a 16-bit memory location, which is normally used to store the value of one of analog inputs associated with a SmartStack I/O module. When used in this way, %AI registers are non-retentive. All extra %AI registers (which are not associated with SmartStack inputs) are retentive and can be used just like %R registers.

d. %AQ Registers

A %AQ Register is a non-retentive 16-bit memory location, which is normally used to store the value of one of the analog outputs associated with a SmartStack I/O module.

e. SmartStack I/O Modules

Local: Up to 4 SmartStack I/O Modules can be plugged into an OCS or RCS, to provide local digital and analog I/O, and/or intelligent I/O, such as ASCII-Basic, High-Speed Counter, Stepper Motor Indexer, Power Monitor and Ethernet communication.

Remote: In addition to local I/O modules, up to 20 remote SmartStack I/O Modules can be connected to an OCS or RCS using five Fiber Optic Bases, which each contain four I/O slots. If a remote I/O connection is desired, the SmartStack FOX100 / 110 module must occupy the local OCS110 / 210/ 250 / or RCS250 Slot 1 position.

Note: Fiber Optic Base modules include the FOX104 and FOX404.

Global Data I/O Registers

Global Data I/O Registers (%IG, %QG, %AIG and %AQG) give the user access to the Network Port's Global I/O data. This data can be accessed via User Screens and/or by Ladder Code.

a. %IG Registers

A %IG Register is a retentive 1-bit memory location, which is normally used to store a global digital state obtained from another Control Station on the network.

b. %QG Registers

A %QG Register is a retentive 1-bit memory location, which is normally used to store a digital state to be sent as global data to the other Control Stations on the network.

c. %AIG Registers

A %AIG Register is a retentive 16-bit memory location, which is normally used to store a global analog value obtained from another Control Station on the network.

d. %AQG Registers

A %AQG Register is a retentive 16-bit memory location, which is normally used to store an analog value to be sent as global data to the other Control Stations on the network.

e. Network Port

The CsCAN Network is based on the Bosch Control Area Network (CAN), and implements the CsCAN Protocol which is designed to take maximum advantage of the global data broadcasting capability of CAN. Using this network protocol, up to 64 Control Stations can be linked without repeaters, and up to 253 Control Stations can be linked by using 3 repeaters. For more information regarding CsCAN Protocol, refer to the **CsCAN Protocol Specification** document.

DeviceNet is an open higher-layer protocol, which is supported by products from multiple vendors. In an OCS or RCS, DeviceNet can be loaded as a replacement for the CsCAN Protocol Message Layer, and as a result, the OCS or RCS becomes a DeviceNet Slave device. Note that the OCS or RCS still implements the CsCAN Protocol Command Layer with respect to the RS232 programming port. For more information regarding DeviceNet Protocol, refer to the **OCS and RCS Communication Capabilities** document, or contact the DeviceNet governing body (ODVA).

Ladder Code

The Ladder Code, stores ladder instructions generated by Cscape. This Ladder Code is downloaded and stored into the Control Station's Flash memory, to be executed each controller scan, when the controller is in RUN mode.

1.4 SmartStack Product Description

The SmartStack Modules provide a wide variety of I/O options for all OCS models and the RCS. Compact and easy to install, SmartStack Modules are used in a multitude of control applications. Up to four Smart Stack Modules can be installed in each device.

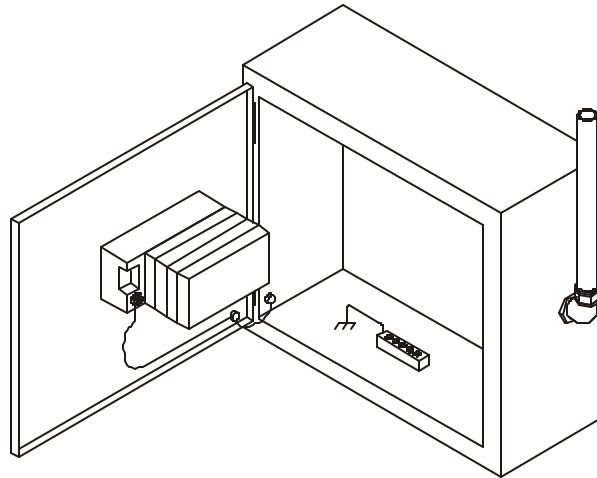

Figure 1.6 - Back View of OCS (Shown with Four SmartStack Modules)

1.5 Relationship of SmartStack Modules, OCS, RCS and FOX Products

SmartStack Modules provide all models of the OCS and RCS with I/O capability. Up to four SmartStack modules can be used with each OCS and RCS. The OCS and RCS have networking capabilities allowing communication with each other. Fiber Optic (FOX) products extend the distance and the number of SmartStacks that can be used. The following table provides a summary of functions.

Table 1.5 - Functions of OCS, RCS, SmartStack Modules, and Fiber Optic Modules (FOX)				
Device	Functions			
	Control	Display and Keypad	Network	I/O
Operator Control Station (OCS) OCS1XX / 2XX Graphic OCS250	Yes	Yes	Yes	Yes
Remote Control Station (RCS) RCS2XX	Yes	Remote Only	Yes	Yes
SmartStack Modules	Provides a wide variety of I/O options for the OCS and RCS. Require little space and are easy to install. Up to <u>four</u> option modules are used in each controller.			
SmartStack Fiber Optic Expansion Module (FOX100 / 110)	Allows an OCS110 / OCS210 / OCS250 and RCS250 to connect up to five Fiber Optic Expansion Systems (e.g.; FOX404 and FOX104).			
Fiber Optic Extension System (FOX104 / 404)	Extends a high-speed OCS/RCS backplane enabling SmartStack I/O Modules to be mounted several meters from the OCS. The FOX, also, significantly increases the number of SmartStack I/O modules supported by one OCS/RCS.			
Fiber Media Converter (SFX100)	Used with the FOX100 or FOX110; it is a plastic-to-glass converter, which can extend the fiber optic link up to 1500m.			

1.6 Differences Between OCS and RCS

Although the OCS models and RCS have control capabilities (via Ladder Logic programming), the OCS models have two key features the RCS does not have including a keypad and a display interface. In place of a keypad to perform functions such as setting the Network ID, two switches on the RCS are used. Two additional LEDs have been added to the RCS (MS and NS lamps) to provide diagnostic information. The RCS has a 3-pin power connector while the OCS has a 2-pin power connector.

The OCS incorporates alphanumeric LCD displays with backlights for the purpose of conveying information to the operator. This same function is available on a remote PC (using Cscape's Remote Text Term function) if the PC is connected to the CsCAN network. The RCS does not have a local display, but it still supports Cscape's Remote Text Term function.

1.7 Fiber Optic (FOX) Products Description

Two categories of Fiber Optic products are available to support Control Station Modules as specified in this section.

a. Fiber Optic Expansion System

The Fiber Optic Extension System extends a high-speed OCS backplane enabling SmartStack I/O Modules to be mounted several meters from the OCS. The FOX, also, significantly increases the number of SmartStack I/O modules supported by one OCS.

IC300FOX104
IC300FOX404

Each FOX Base supports 4 SmartStack Modules.

Each FOX Supports 4 SmartStack Modules plus 4 additional I/O Bases.

b. SmartStack Fiber Optic Extension Module (Used with OCS110/210/250 and RCS250)

The SmartStack Fiber Optic Extension Module (**FOX100 / FOX110**) allows an OCS110 / OCS210 / OCS250 and RCS250 to connect up to five Fiber Optic Expansion Systems (e.g.; FOX404 and FOX104).

A **Fiber Media Converter (SFX100)** can be used with the FOX100 or FOX110; it is a plastic-to-glass converter, which can extend the fiber optic link up to 1500m.

Note: The SFX100 can be used with the OCS110 / OCS210 / OCS250 and RCS250.
It can not be used with the OCS100 / OCS200.

1.8 NEMA-Rated Models

The following products carry the UL NEMA ratings for Enclosure Evaluation for Type 4, 4x, 12 Ratings when installed in a Type 4, 4x or 12 Rated Enclosure.

These products contain keypad inserts.

OCS100-18
OCS110-18
OCS200-18
OCS210-18

These products do not contain keypad inserts.

OCS100-19
OCS110-19
OCS200-19
OCS210-19

Refer to the installation chapters for each product to determine Torque specifications.

1.9 Technical Support

For assistance, contact Technical Support at the following locations:

North America:

1-800-433-2682 or visit our website at www.gefanuc.com.

Europe:

(+) 353-21-4321-266

CHAPTER 2: INSTALLATION

2.1 General

Installation information is covered in Chapter Two that applies to one or more models of the OCS or the RCS. Product-specific information is covered in individual chapters for the various products discussed in this manual. Examples of product-specific information includes:

- a. Dimensions and panel cut-outs
- b. Mounting instructions and orientation
- c. Some types of connectors and other hardware

Note: It is important to consult both this chapter and the individual product chapter for installation information.

2.2 Factors Affecting Panel Layout Design and Clearances

Warning: It is important to follow the requirements of the panel manufacturer and to follow applicable electrical codes and standards.

The designer of a panel layout needs to assess the requirements of a particular system and to consider the following design factors. *A convenient checklist is provided in Section 2.2.1.*

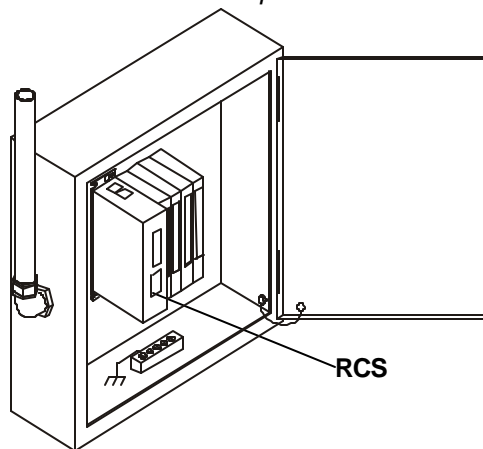

Figure 2.1 – RCS in Panel Box (Shown with Four SmartStack Options)

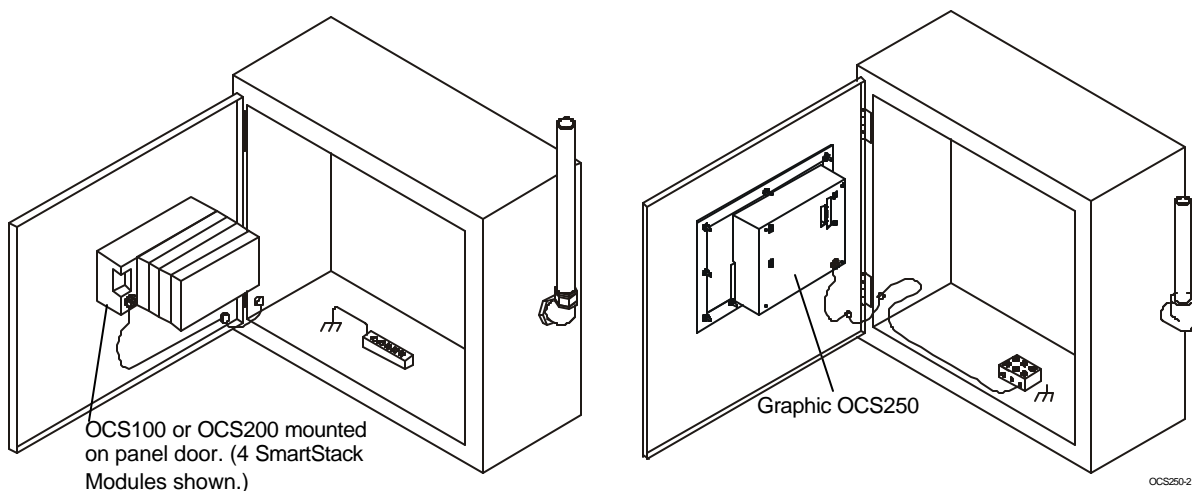

Figure 2.2 – OCS Models on Panel Door

a. Clearance / Adequate Space

Install devices to allow sufficient clearance to open and close the panel door.

Table 2.1 – Minimum Clearance Requirements for Panel Box and Door	
Minimum Distance between base of device and sides of cabinet	2 inches (50.80 mm)
Minimum Distance between base of device and wiring ducts	1.5 inches (38.10 mm)
<u>If more than one device installed in panel box (or on door):</u> Minimum Distance between bases of each device	4 inches (101.60 mm) between bases of each device
<u>When door is closed:</u> Minimum distance between device and closed door (Be sure to allow enough depth for SmartStack Modules.)	2 inches (50.80 mm)
To allow optimum use of the SmartStack Module Options: Up to <u>four</u> SmartStack Modules may be installed in each OCS or RCS. It is important to consider the <i>depth</i> required in a panel box to allow optimum use of the SmartStack Options.	Refer to Figures 2.1 –2.9 for OCS and SmartStack dimensions.

b. Grounding

Warning: Be sure to meet the ground requirements of the panel manufacturer and also meet applicable electrical codes and standards.

Panel box: The panel box needs to be properly connected to earth ground to provide a good common ground reference.

Panel door: Tie a low impedance ground strap between the panel box and the panel door to ensure that they have the same ground reference.

Devices in panel box and on the panel box door:

1. Use the mounting hardware provided with the device, which includes star washers.
2. Remove the paint (to bare metal) around the screw holes where star washers will be placed when installing the device. Clean the bare metal and ensure that it is free of dust and other particles.

Note: Remove paint from screw holes located inside the panel box and the interior of the panel box door. These locations are where the star washers actually come in contact with the bare metal.

3. Use the star washers on the mounting stud of the device to provide better contact between the mounting hardware and the panel surface. Ensure that a good solid contact is made against bare metal for proper grounding.

c. Temperature / Ventilation

Ensure that the panel layout design allows for adequate ventilation and maintains the specified ambient temperature range. Consider the impact on the design of the panel layout if operating at the extreme ends of the ambient temperature range. For example, if it is determined that a cooling device is required, allow adequate space and clearances for the device in the panel box or on the panel door.

d. Orientation

Observe guidelines for proper orientation of the bases when mounting the OCS and RCS. (Refer to individual product chapters.) Proper orientation helps to ensure a good connection when SmartStack Modules are installed into the devices.

e. Noise

Consider the impact on the panel layout design and clearance requirements if noise suppression devices are needed. Be sure to maintain an adequate distance between the OCS or RCS and noisy devices such as relays, motor starters, etc.

Note: Do not route power and signal wires in the same conduit.

f. NEMA Ratings

To meet NEMA for Enclosure Evaluation for Type 4, 4x, 12 Ratings, products must be installed in a Type 4, 4x or 12 Rated Enclosure.

2.2.1 Panel Layout Design and Clearance Checklist:

The following list provides highlights of the panel layout design factors discussed in Section 2.2 (a.-f).

___ Meets the electrical code and applicable standards for proper grounding, etc.?

___ Meets the panel manufacturer's requirements for grounding, etc.?

___ Is the panel box properly connected to earth ground? Is the panel door properly grounded? Has the appropriate procedure been followed to properly ground the devices in the panel box and on the panel door? (See Section 2.2 [b].)

___ Are minimum clearance requirements met? (See Table 2.1.) Can the panel door be easily opened and closed? Is there adequate space between device bases as well as the sides of the panel and wiring ducts?

___ Is the panel box deep enough to accommodate the *optimum* use of the SmartStack Option Modules? Up to four SmartStack Modules may be installed in each OCS. (Refer to individual product chapters containing dimension figures and panel cut-outs.)

___ Are the device bases oriented correctly? (See Section 2.1.3.) The OCS devices are mounted on the door of a panel box.

___ Is there adequate ventilation? Is the ambient temperature range maintained? Are cooling or heating devices required?

___ Are noise suppression devices or isolation transformers required? Is there adequate distance between the base of the OCS or RCS and noisy devices such as relays or motor starters? Ensure that power and signal wires are not routed in the same conduit.

___ Are there other requirements that impact the particular system, which need to be considered?

___ If applicable, does the enclosure meet NEMA requirements? (See Section 2.2[Item f].)

2.3 Ports, Connectors and Wiring

Note: For RCS Primary Power Port, refer to Section 5.6.

2.3.1 Primary Power Port

Table 2.2 – Primary Power Port Pins		
Pin	Signal	Description
1	V+	Input power supply voltage
2	V-	Input power supply ground

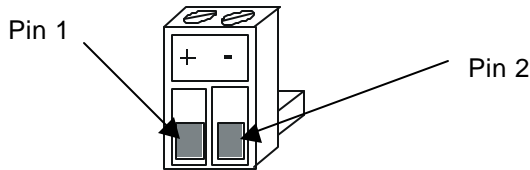

Note: Power Supply Voltage Range is from 10-30 VDC.

Figure 2.3 Power Connector
(Primary Power Port)



Figure 2.4 As viewed looking
at the OCS models

2.3.2 CAN / DeviceNet Network Port and Wiring

a. Network Connector

Table 2.3 – CAN Port Pins		
Pin	Signal	Description
1	V-	Power -
2	CN_L	Signal -
3	SHLD	Shield
4	CN_H	Signal +
5	V+	Power +

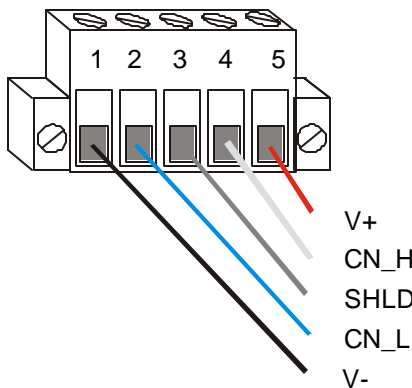

Figure 2.5 – Network Connector

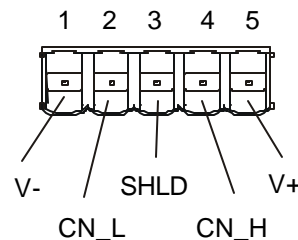

Figure 2.6 – As viewed at the OCS

b. Wiring

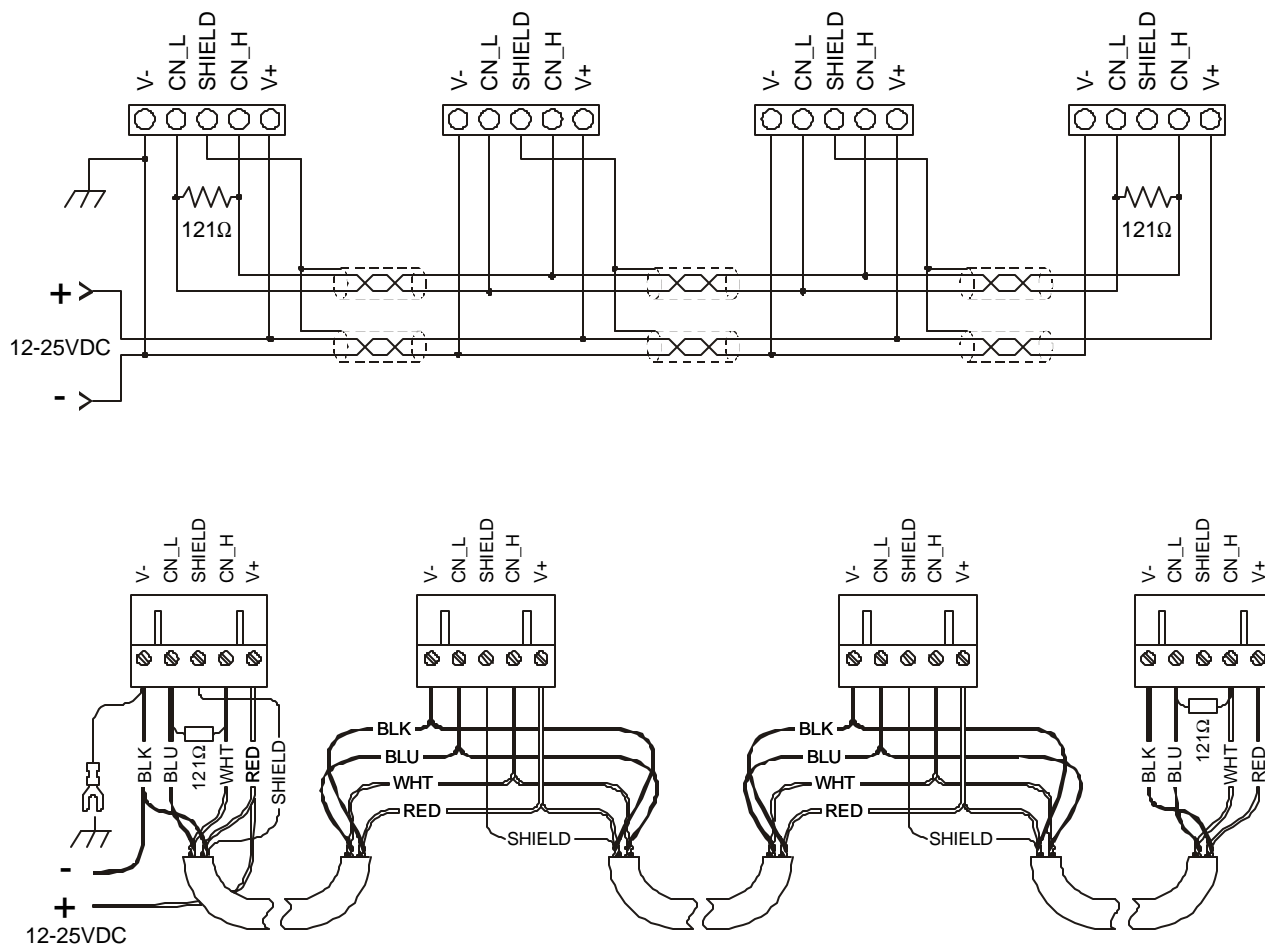

Figure 2.8 – CAN Wiring

Note: To optimize CAN network reliability in electrically noisy environments, the CAN power supply needs to be isolated (dedicated) from the primary power.

CAN Wiring Rules (See Figure 2.8.)

1. Wire the CAN network in a daisy-chained fashion such that there are exactly two physical end-points on the network.
2. The two nodes at the physical end-points need to have 121 ohm 1% terminating resistors connected across the CN_L and CN_H terminals.
3. Use data conductors (CN_L and CN_H) that are 24 AWG shielded twisted pair for “thin cable” and 22 AWG shielded twisted pair for “thick cable.” They must also have 120-ohm characteristic impedance. In typical industrial environments, use a Belden wire #3084A (“thin”). Use #3082A (“thick”) for network cable lengths greater than 100 meters environments where noise is a concern. Place data conductors (CN_L and CN_H) into a twisted pair together.
4. Use power conductors (V- and V+) that are 18 AWG twisted-pair for “thin cable” and 15 AWG twisted-pair for “thick cable.” Place power conductors (V- and V+) into a twisted pair together.
5. If local codes require the local CAN power supply to be earth grounded, connect the V- power conductor to a good earth ground **at one place only** on the network, preferably at a physical endpoint. If multiple power supplies are used, only one power supply must have V- connected to earth ground. The remaining power supplies need to be isolated.

6. For a section of cable between two nodes, the cable shield is connected to the cable shield input at *one end of the cable only*.
7. A CAN network (without repeaters) is limited to 64 nodes (with 63 cable segments) with a maximum combined cable length of 1500 ft. at 125KBaud.
8. Up to four CAN network segments, which adhere to the above rules, may be connected together using three CAN repeaters. In this manner, a CAN network may be extended to 253 nodes with a total cable distance of 6000 ft. at 125KBaud.

c. CsCAN or DeviceNet Cable

Note: For more details about DeviceNet networks, refer to *DeviceNet ä Implementation Using Control Station Modules* (GFK-1763). -

The 5-wire, multi-conductor copper cable used in CsCAN or DeviceNet network include:

1. Two wires used as a transmission line for network communications.
2. Two wires used to transmit network power.
3. One conductor used as an electromagnetic shield.

Cabling is available in a variety of current-carrying capacities. On a CsCAN or DeviceNet fieldbus, every device must, at least, power its network transceivers from the network power supply. Some devices draw all of their power from the network supply. In CsCAN or DeviceNet, thick and thin cable is used as indicated:

1. **Thick cable:** Use for long distances and more power. Usually used for Trunk cable.
2. **Thin cable:** Use for shorter distances. Usually used for drop cables or where cable flexibility is needed.

Table 2.4 - CsCAN / DeviceNet Cable Specifications	
Thick Cable – general specifications (e.g., Belden 3082A)	Two twisted shielded pairs –Common axis with drain wire in center. One signal pair (#18), blue/white; One power pair (#15) black/red. Separate aluminized mylar shields around power pair and signal pair. Overall foil/braid shield with drain wire (#18), bare*. High Speed (Vp=75% min), low loss, low distortion, data pair (to keep propagation delays to a minimum). 8 amp maximum current capacity. PVC insulation on power pair. Industrial temperature range. High flexibility.
Thin Cable – general specifications (e.g., Belden 3084A)	Two twisted shielded pairs –Common axis with drain wire in center. One signal pair (#24), blue/white; One power pair (#22) black/red. Separate aluminized mylar shields around power pair and signal pair. Overall foil/braid shield with drain wire (#22), bare*. High Speed (Vp=75% min), low loss, low distortion, data pair (to keep propagation delays to a minimum). 3 amp maximum current capacity. PVC insulation on power pair. Industrial temperature range. High flexibility
Network Topology	Bus with limited branching (truckline / dropline)
Redundancy	Not Supported
Network Power for Node devices	Nominal 24 VDC ±4%
Allowed Nodes (Bridging excluded)	64 nodes
Data Packet Size	0-8 bytes with allowance for message fragmentation
Duplicate Address Detection	Addresses verified at power-up
Error Detection / Correction	CRC – retransmission of message if validity not acknowledged by recipient.
* The drain wire connects shields within the cable and serves as a means to terminate the shield into the connector.	

d. Bus Length

Several factors affect the maximum length of the bus including the accumulated length of drop lines, cable type, transfer rate and the number of drop lines. Although a branch is limited to one network per drop, it can have multiple ports. A branch can not exceed 6 meters.

Table 2.5 - CAN Network Baudrate vs. Total Cable Length	
Note: The following values apply to both CsCAN or DeviceNet except as indicated.	
Thick Cable: Network Data Rate	Maximum Total Cable Length
1Mbit / sec. (Does not apply to DeviceNet.)	40m (131 feet)
500Kbit / sec.	100m (328 feet)
250Kbit / sec.	200m (656 feet)
125Kbit / sec.	500m (1,640 feet)
Thin Cable Maximum Total Cable Length	
Maximum bus length is independent of network data rate. Maximum bus length is 100m.	

e. Bus Power and Grounding

When using CsCAN or DeviceNet:

1. A power supply of 24VDC ($\pm 4\%$) at 16A maximum is required for use in a CsCAN / DeviceNet network
2. With thick cable, a single network segment can have a maximum of 8A. To do this, the power supply needs to be located in the center of two network segments.
3. Thin cable has maximum of 3A.
4. To ground the cable shield, connect to pin 3 as shown in Figure 2.8.
5. If local codes require the local CAN power supply to be earth grounded, connect the V- power conductor to a good earth ground **at one place only** on the network, preferably at a physical endpoint. If multiple power supplies are used, only one power supply must have V- connected to earth ground. The remaining power supplies need to be isolated.

2.3.3 RS-232 Programming Port and Wiring

Table 2.6 – RS-232 Port Pins			
Pin	Signal	Description	Direction
1	DCD	Always high	Out
2	RXD	Received Data	Out
3	TXD	Transmitted Data	In
4	DTR	Data Terminal Ready	In
5	GND	Ground	-
6	DSR	Data Set Ready	Out
7	RTS	Request to Send	In
8	CTS	Clear to Send	Out
9	RI	Ring Indicate	Out

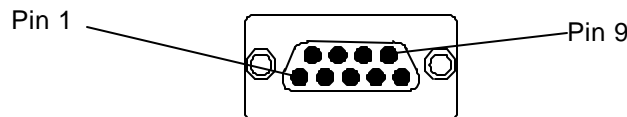

Figure 2.9 – RS-232 Port

a. OCS1XX and OCS2XX

The OCS units feature an RS-232 port (Programming/Debug) for connection to a personal computer. This port is used for the purposes of OCS programming, configuring, monitoring, and debugging. This port can also be used for general ladder logic controlled serial communications to printers, modems, terminals, etc. When ladder has control of this port, it is not available for programming or debugging. If a permanent connection is to be made between the OCS and the personal computer, the use of a shielded, multiple conductor wire with a maximum length of 15.24 meters (50 feet) enables proper performance.

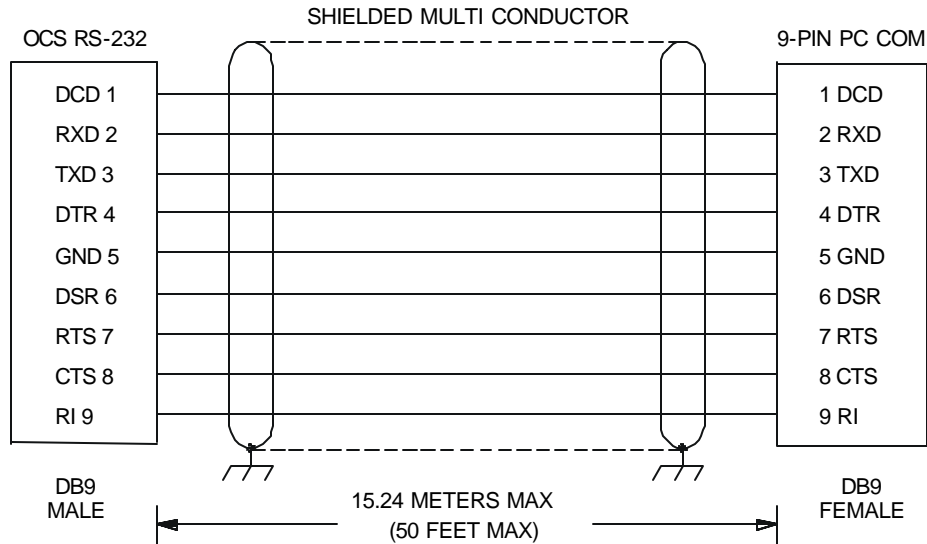

Figure 2.10 – OCS RS-232 to PC Wiring Diagram

b. Graphic OCS (OCS250)

The Graphic OCS features primary and secondary RS-232 ports. Both primary and secondary RS-232 port pin-outs are shown in Table 2.6. The primary RS-232 port (Programming/Debug) is for connection to a PC.

The secondary port includes an RS-232 or RS-485. Only one of these secondary ports can be selected for use at any given time. The secondary serial port is used for application communications such as bar code readers, etc.

The primary RS-232 port (Programming/Debug) is for connection to a PC as well as application communications. This port is used for the purposes of Graphic OCS programming, configuring, monitoring, and debugging. This port can also be used for general ladder logic controlled serial communications to printers, modems, terminals, etc. When ladder has control of this port, it is not available for programming or debugging. For connection between the Graphic OCS and the PC, the use of a shielded, multiple conductor wire with a maximum length of 15.24 meters (50 feet) enables proper performance.

Note: A shorter cable may be required when using the port at baud rates above 9600.

2.3.4 RS-485 Connector (Graphic OCS250 only)

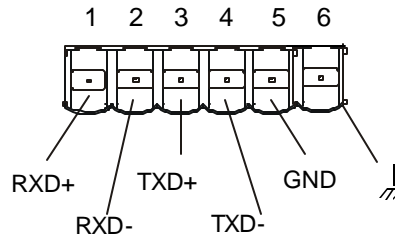

Figure 2.11 -- RS-485 Connector (Graphic OCS only.)

2.3.5 Modem Setup

A modem can be used for remote communications between a computer (using Cscape Software) and the OCS. The modem must operate at 9600 baud or higher.

A modem can be used for remote communications between a computer (using Cscape Software) and the Graphic OCS. The modem must operate at 9600 baud or higher.

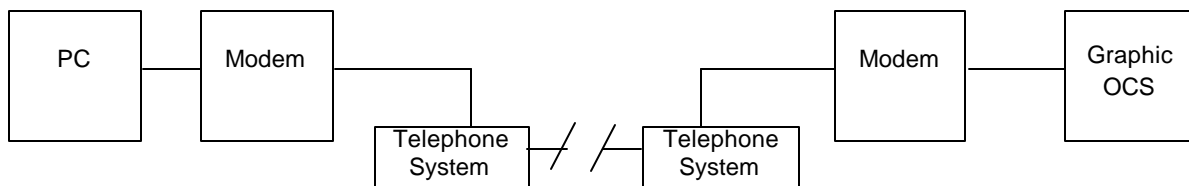

Figure 2.12 – Modem Setup

a. Setup Parameters

Setup the modems to match the default serial port characteristics of the OCS.

- 9600 baud
- 8 data bits
- No parity
- 1 stop bit
- disable error checking
- disable compression

b. Cable Wiring

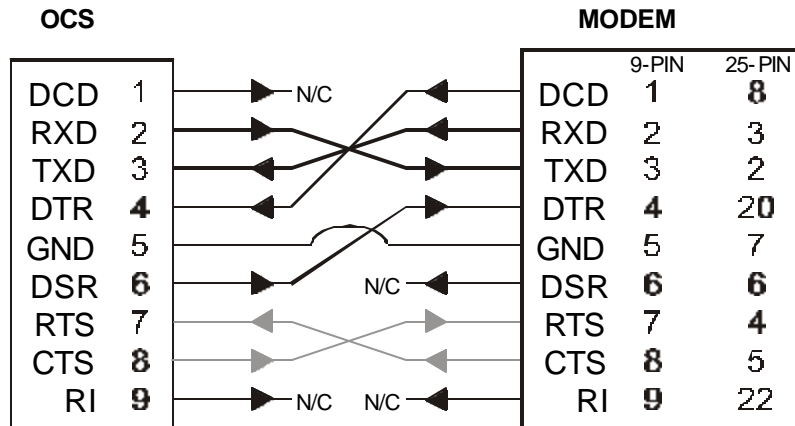

Figure 2.26 – Modem Wiring

Note: If the modem has a DB25 connector, a 9-to-25-pin adapter may need to be supplied.

The grayed connections —▶ are used only if hardware handshaking between the controller and modem is required.

The wire type used in not overly critical except where the length of the cable must be between 30 and 50 feet (10 to 15 meters). In all cases, the cable must be shielded multi-conductor with conductors of at least 20 gauge. The length of the cable must be as short as possible, and in no case, longer than 50 feet (15 meters).

The modem must be located as close as possible to the OCS, preferably less than one meter. However, EIA-232 specifications allow for cable runs up to 50 feet (15 meters). If cable lengths longer than 30 feet (10 meters) are required, a special low capacitance cable must be used.

Warning: Damage can result if the CD and RI lines are connected to each other or to any other signal on the connector or through the cable to the other unit.

Warning: To connect a modem to the OCS the controller to modem cable must be constructed or purchased. Using a Null Modem cable can cause damage to the OCS, modem, or both.

c. Recommended Modem

Selection of a telephone modem for use with the OCS is highly dependent on environment. For a relatively benign, low-noise environment, an off-the-shelf external modem like a U.S. Robotics Sportster Modem can work well. For a more industrial environment, however, it is appropriate to use a telephone modem designed for that environment. Manufacturers such as Datalinc and Sixnet have models, which have been known to work in more harsh environments, at a higher cost. If a modem is used, which is not appropriate for the environment, there may be little that can be done to correct the situation other than change to a more appropriate model.

For detailed information regarding the use of modems with Control Station Products, contact Technical Support (Chapter One). You can also find specific application information (cabling, modem commands, etc.) in the Cscape Help file as well.

2.4 Installing and Removing a SmartStack Module (Shown with the OCS)

The following section describes how to install and remove a SmartStack Module.

Caution: To function properly and avoid possible damage, do not stack more than four Smart Stack Modules per OCS or RCS or FOX100.

a. Installing SmartStack Modules

1. Hook the tabs. Each SmartStack Module has two tabs that fit into slots located on the OCS. (The slots on the OCS are located on the back cover.)
2. Press the SmartStack Module into the "locked" position, making sure to align the SmartStack Module fasteners with the SmartStack receptacles on the OCS.

b. Removing SmartStack Modules

1. Using a flathead screwdriver, pry up the end of the SmartStack Module (opposite of tabs) and swing the module out.
2. Lift out the tabs of the module.

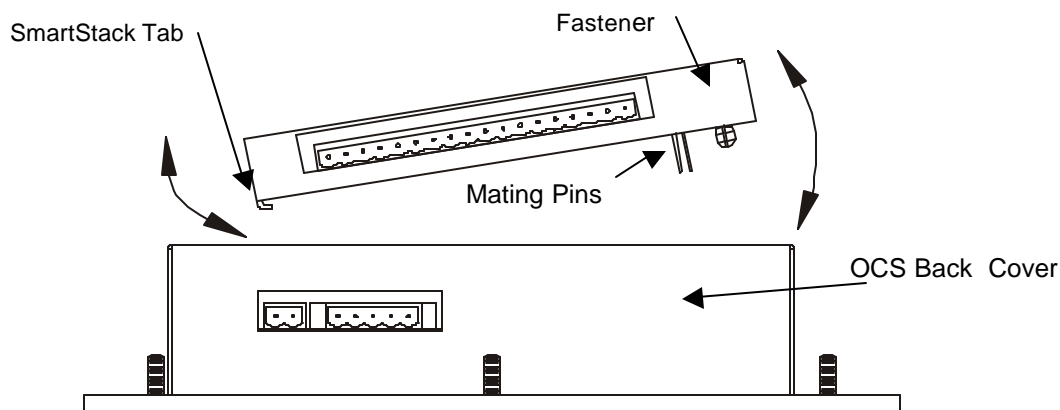

Figure 2.14 – Installing a SmartStack Module in an OCS

2.5 Selecting DeviceNet Network (Firmware Update Wizard)

To use the OCS in a DeviceNet network, use Cscape's Firmware Update Wizard. Select **File, Firmware Update Wizard** from the pull-down menu. The following screen appears.



Figure 2.15 – Using Firmware Update Wizard

Select the product type and click on the circle next to the desired network. Press **OK**. On the next screen, press **Send**. Firmware is now updated.

2.6 LEDs (OCS / Graphic OCS / RCS Models)

2.6.1 LEDs for OCS / RCS

Refer to the following diagrams and LED table for OCS / RCS LEDs.

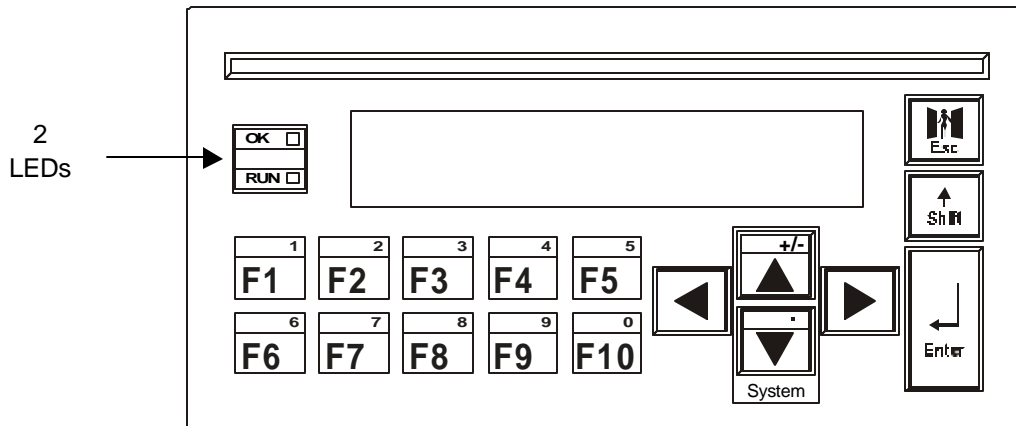

Figure 2.16 – OCS1XX LEDs
(OCS2XX LEDs are located on its front panel.)

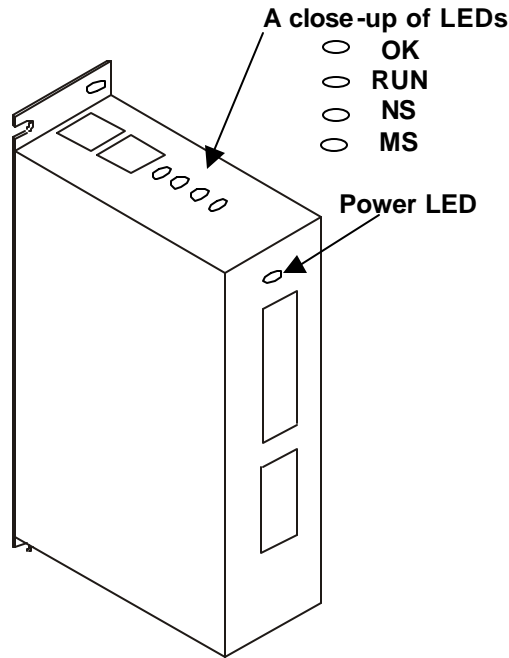

Figure 2.17 – RCS LEDs

Table 2.7 – LEDs (OCS and RCS)		
LED	OCS	RCS
RUN	<ul style="list-style-type: none"> • OFF indicates OCS is in IDLE/STOP mode. • Flashing indicates DO / IO mode or RUN with no ladder program. • ON indicates ladder code running. 	
OK	<ul style="list-style-type: none"> • OFF indicates one or more self-tests failed. • ON indicates all self-tests passed. 	
<p>Module Status (MS) MS monitors RS-232 activity.</p>		<ul style="list-style-type: none"> • OFF indicates no communication. • Orange flashing light indicates communication activity (send and receive) between the RCS and the RS-232 serial port. • Red light ON indicates transmit data being transferred on the RS-232 port. • Green light ON indicates receive data being transferred on the RS-232. <p>During Self-test:</p> <ul style="list-style-type: none"> • Flashing Red light at 1Hz rate: critical self-test error is detected. • Solid Red Light ON: Indicates <i>non-critical</i> self-test error is detected.
<p>Network Status (NS) NS monitors CAN port activity.</p>		<ul style="list-style-type: none"> • OFF indicates no communication. • Orange flashing light when communication activity (send and receive) occurs between the RCS and the CAN Network port. • Red light ON indicates transmit data being transferred on the CAN Network port. • Green light ON indicates receive data being transferred on the CAN Network port.

2.6.2 LEDs for Graphic OCS (OCS250)

The Graphic OCS (OCS250) has ten user-controlled LEDs. LEDs are controlled via %SR LED_1 to LED_10. If desired, LEDs can be tied to the function keys of the Graphic OCS.

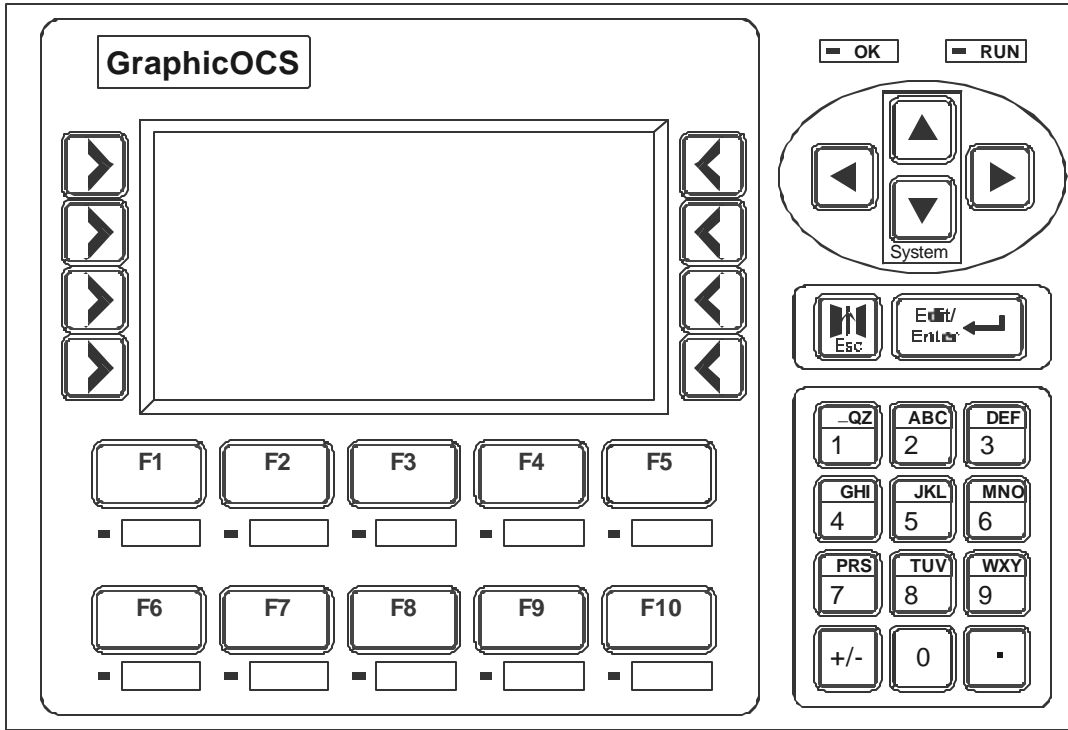

Figure 2.18 – OCS250 LEDs

CHAPTER 3: OCS1XX AND OCS2XX

3.1 General

Installation information is covered in Chapter Two that applies to one or more models of the OCS or the RCS. Product-specific information is covered in this chapter pertaining to the OCS1XX and OCS2XX. Examples of product-specific information includes:

- a. Mounting orientation and instructions
- b. Dimensions and panel cut-outs
- c. Some types of connectors and other hardware

Note: It is important to consult both this chapter and Chapter Two for installation information.

3.2 Mounting Orientation

The base of the OCS needs to be mounted with the proper orientation. Proper orientation helps to ensure a good connection when SmartStack Modules are installed. Up to four SmartStack Modules can be installed **locally** per OCS. The OCS is mounted on a door of a panel box.

Caution: Do not stack more than four SmartStack Modules per OCS / RCS / FOX. Improper operation or damage to the OCS / RCS / FOX and SmartStack Modules can result.

Expansion: In addition to local I/O modules, up to 20 SmartStack I/O Modules can be connected to an OCS or RCS using five Fiber Optic Bases (FOX104 / 404), which each contain four I/O slots. If an expanded I/O connection is desired, the SmartStack FOX100 / 110 module must occupy the local OCS110 / 210/ 250 / or RCS250 Slot 1 position. See Chapter 9 and 10.

- a. Orientation of the OCS1XX and OCS2XX

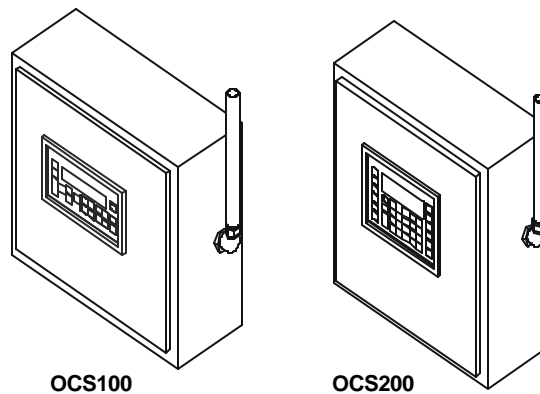

NOTE: There are NO orientation restrictions on the OCS. *However, the above orientation provides for optimum readability of the screen and ease of use of the keypad.*

Figure 3.1 - OCS100 and OCS200 Orientation

3.3 Mounting Requirements

To ensure the proper operation of the OCS Modules, follow the installation guidelines and procedures covered in Chapter Two.

3.3.1 Mounting Procedures

The OCS is designed for permanent panel mounting. To install the OCS, follow the instructions below and use the provided template.

1. Read Chapter Two prior to mounting the OCS. Observe requirements for the panel layout design and adequate clearances. A checklist is provided for the user's convenience in Section 2.2.1
2. Cut the host panel. (Refer to Figures 3.2 – 3.7.)

Warning: Make sure the power and network connectors are removed from the OCS.

3. Insert the OCS through the panel cutout (from the front). The gasket material needs to lie between the host panel and the OCS panel.
4. Install and tighten washers and nuts until the gasket material forms a tight seal. Do not over-tighten.

NEMA Torque specifications (if applicable):

OCS100 and OCS110 and OCS200 and OCS210: 10 in.-lbs. (1.13 Nm).

OCS100 and OCS110: Install the six washers and hex nuts on the six mounting studs of the OCS.

OCS200 and OCS210: Install the eight washers and hex nuts on the eight mounting studs of the OCS.

5. Connect the communications and power cables to the OCS ports using the provided connectors.
6. Install up to four SmartStack Modules on the OCS. Begin configuration procedures for the OCS and then the SmartStack Modules.

3.3.2 OCS and SmartStack Dimensions and Panel Cut-outs

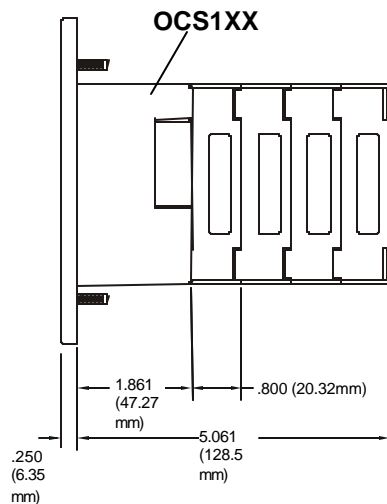

**Figure 3.2 –Side View of OCS1XX
(Shown with Four SmartStack Modules)**

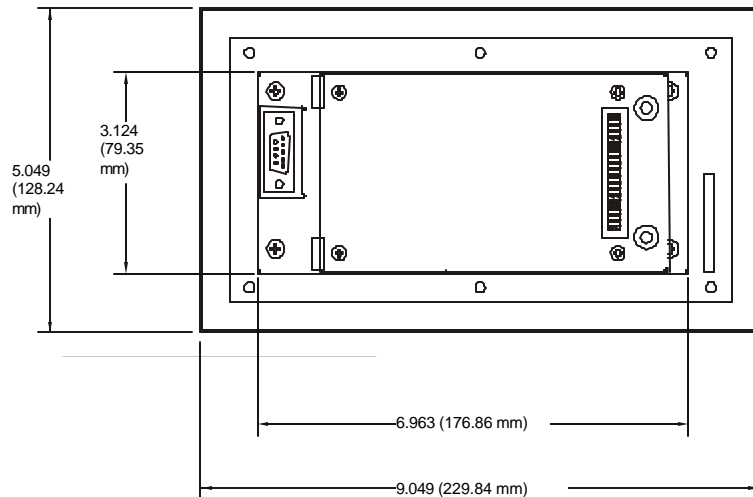

**Figure 3.3– Back View of OCS1XX
(Shown with SmartStack Modules installed)**

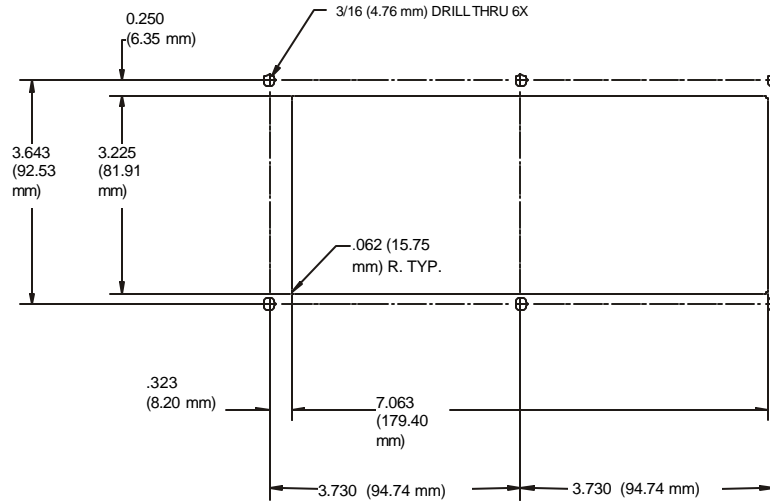

Figure 3.4 – Panel Cut-out for the OCS1XX

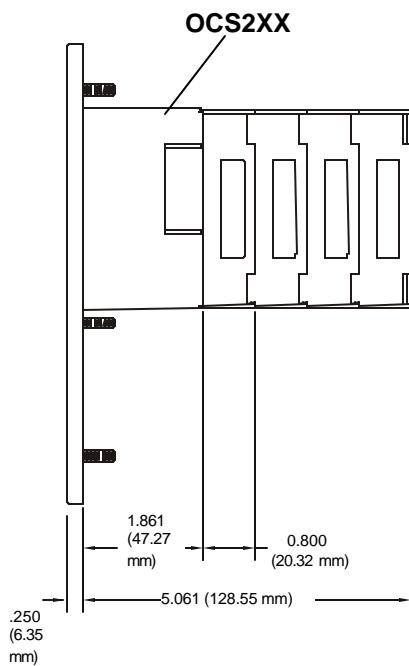

Figure 3.5–Side View of OCS2XX
(Shown with Four SmartStack Modules)

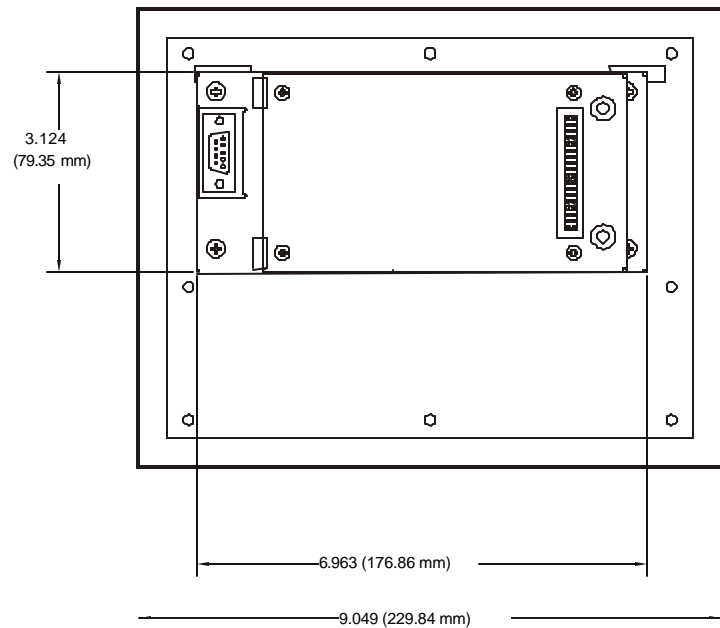

Figure 3.6 – Back View of OCS2XX
(Shown with SmartStack Modules installed)

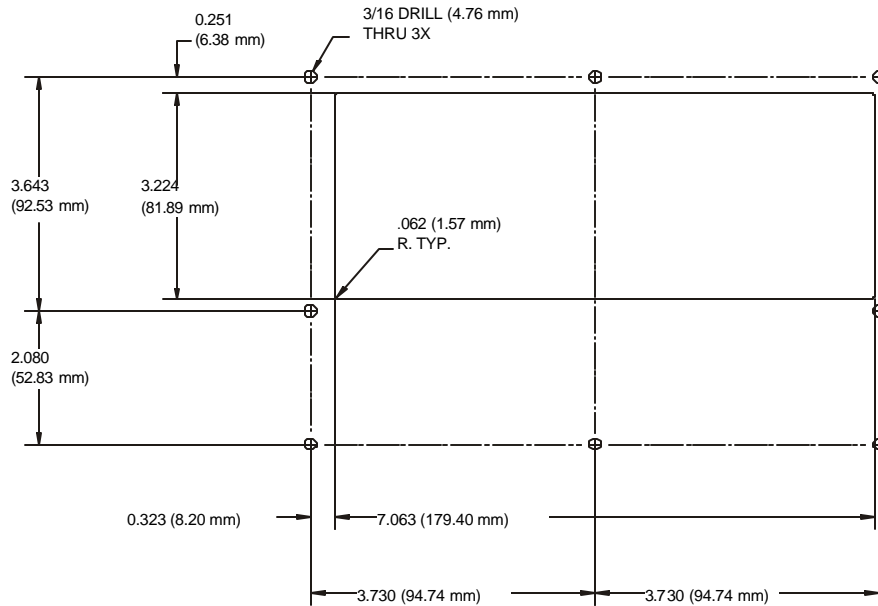

Figure 3.7 – Panel Cut-out for the OCS2XX

3.4 OCS Ports, Connectors, and Wiring

3.4.1 Power, Network, and Programming Ports

The OCS1XX and OCS2XX Power and Network Ports are located on the bottom side of the back cover metal as depicted in Figure 3.8 and 3.9. The Config/Debug port and the SmartStack I/O Module receptacle are located on the backside of the back cover metal.

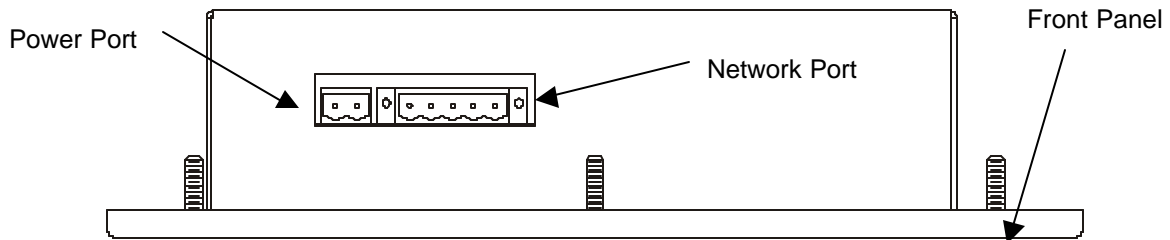

Figure 3.8 – Power and Network Ports for the OCS1XX / 2XX

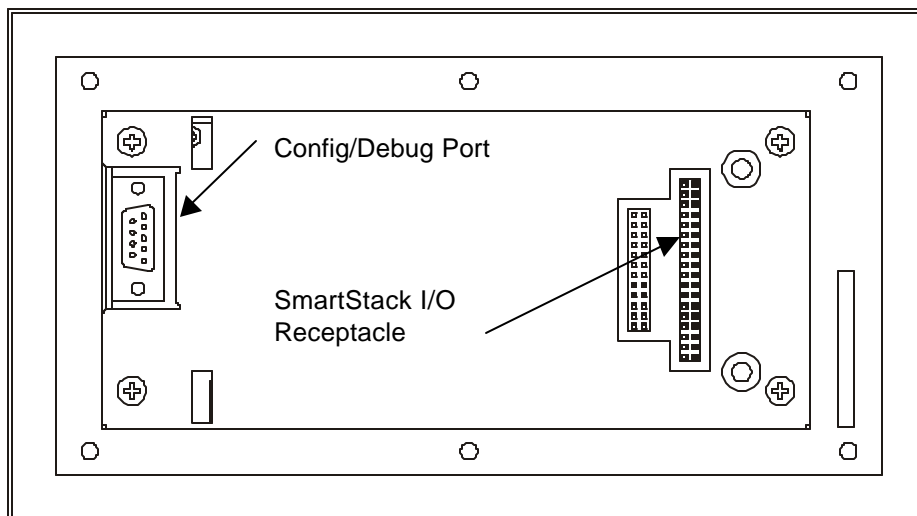

Figure 3.9 – Config/Debug Port and SmartStack I/O Receptacle

3.5 Battery Replacement for the OCS1XX / 2XX (HE500BAT005)

To replace battery, refer to following steps and Figure 3.10.

1. Disconnect power from the OCS unit.
2. Remove ground screw (item #1) from back of the OCS unit. (Note: Some OCS units may not be equipped with this style grounding.)
3. Remove all I/O modules from the back of the OCS.
4. Remove four (4) 6-32 flat head screws (item #2) and slide back cover (item #3) away from the unit.
5. Once the CPU board is exposed, locate the battery (item #4, U6). Remove the battery by prying up slightly on each end until it lifts free. Be sure to dispose of the battery properly.

Warning: Disposal of lithium batteries must be done in accordance with federal, state, and local regulations. Be sure to consult with the appropriate regulatory agencies *before* disposing batteries.

In addition, do not re-charge, disassemble, heat or incinerate lithium batteries.

6. Replace the battery with HE500BAT005 noting the polarity tab at one end of the battery. Use care when replacing the battery that this tab is located in the right direction. Use only the authorized battery part number shown above.

Warning: Do not make substitutions for the battery. Be sure to only use the authorized part number to replace the battery.

7. Reassemble the OCS unit by replacing the back cover and reinstalling the four 6-32 screws. Reattach the ground wire and reinstall the I/O modules. Follow the instructions in the units' manual for powering up the OCS and restoring it to operation.

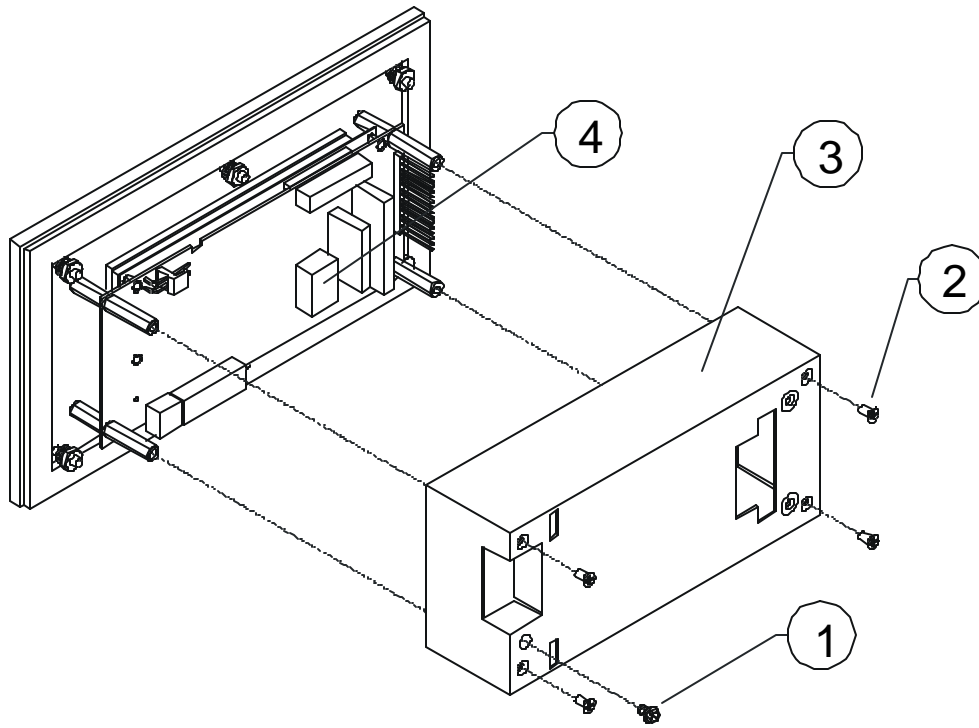

Figure 3.10 – Battery Replacement for the OCS1XX / 2XX

CHAPTER 4: GRAPHIC OCS (OCS250)

4.1 General

Installation information is covered in Chapter Two that applies to one or more models of the OCS or the RCS. Product-specific information is covered in this chapter pertaining to the Graphic OCS (OCS250). Examples of product-specific information includes:

- a. Mounting orientation and instructions
- b. Dimensions and panel cut-outs
- c. Some types of connectors and other hardware

It is important to consult both this chapter and Chapter Two for installation information.

4.2 Mounting Orientation

The base of the Graphic OCS needs to be mounted with the proper orientation. Proper orientation helps to ensure a good connection when SmartStack Modules are installed. Up to four SmartStack Modules can be installed locally per Graphic OCS. The Graphic OCS is mounted on a door of a panel box.

Caution: Do not stack more than four SmartStack Modules per OCS/ RCS / FOX. Improper operation or damage to the OCS/ RCS/ FOX and SmartStack Modules can result.

Expansion: In addition to local I/O modules, up to 20 SmartStack I/O Modules can be connected to an OCS or RCS using five Fiber Optic Bases (FOX104 / 404), which each contain four I/O slots. If an expanded I/O connection is desired, the SmartStack FOX100 / 110 module must occupy the local OCS110 / 210/ 250 / or RCS250 Slot 1 position. See Chapter 9 and 10.

- a. Orientation of the Graphic OCS (OCS250)

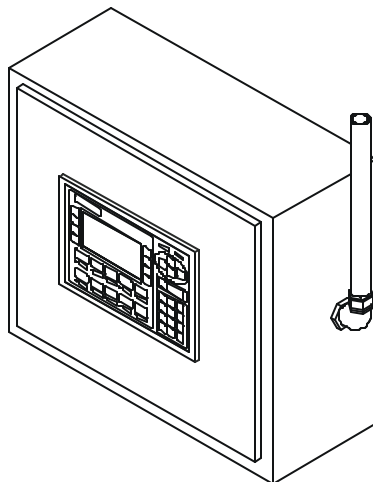

Figure 4.1 – Orientation of Graphic OCS (Shown in Panel Box)

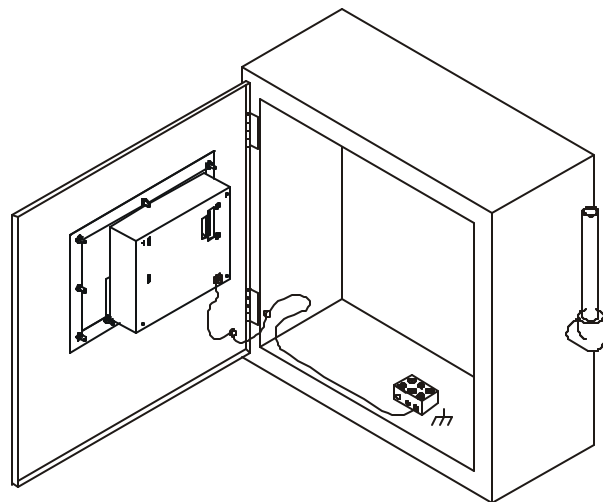

Figure 4.2 –Back View of Graphic OCS (Shown in Panel Box)

OCS250-2

NOTE: There are NO orientation restrictions on the OCS. *However, the above orientation provides for optimum readability of the screen and ease of use of the keypad.*

b. Graphic OCS (Installed in Panel Door)

The Graphic OCS is designed for permanent panel mounting. To install the Graphic OCS, follow the instructions below.

1. Prior to mounting the Graphic OCS, observe requirements for the panel layout design and adequate clearances. A checklist is provided in Section 2.2.1
2. Cut the host panel. (Refer to Figures 4.3 - 4.7.)

Warning: Make sure the power and network connectors are removed from the Graphic OCS.

3. Insert the Graphic OCS through the panel cutout (from the front). The gasket material needs to lie between the host panel and the Graphic OCS panel.
4. Install and tighten the mounting clips (Figure 4.6a) or mounting clamp (Figure 4.6b) that is provided with the Graphic OCS) until the gasket material forms a tight seal.

Caution: Do not over-tighten. Over-tightening can potentially damage the case.

5. Connect the communications, programming, and power cables to the Graphic OCS ports using the provided connectors.
6. Begin configuration procedures for the Graphic OCS models.

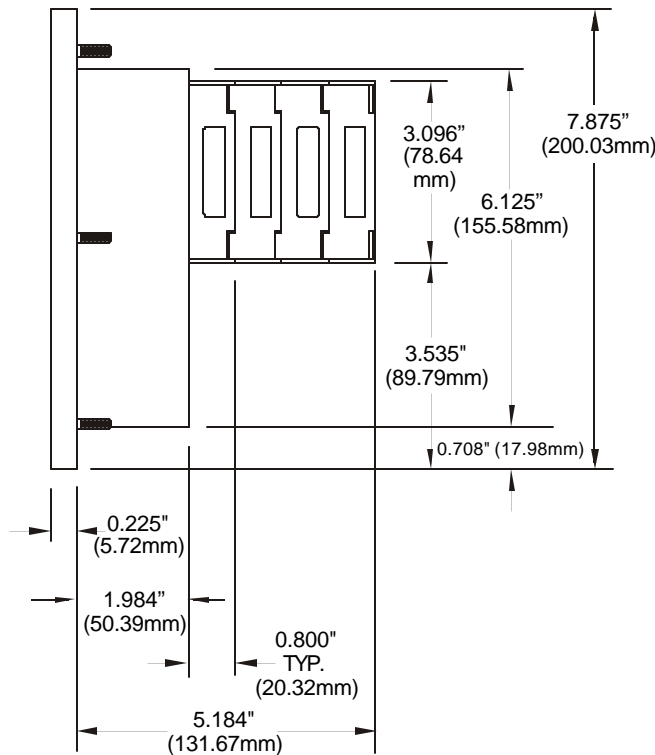
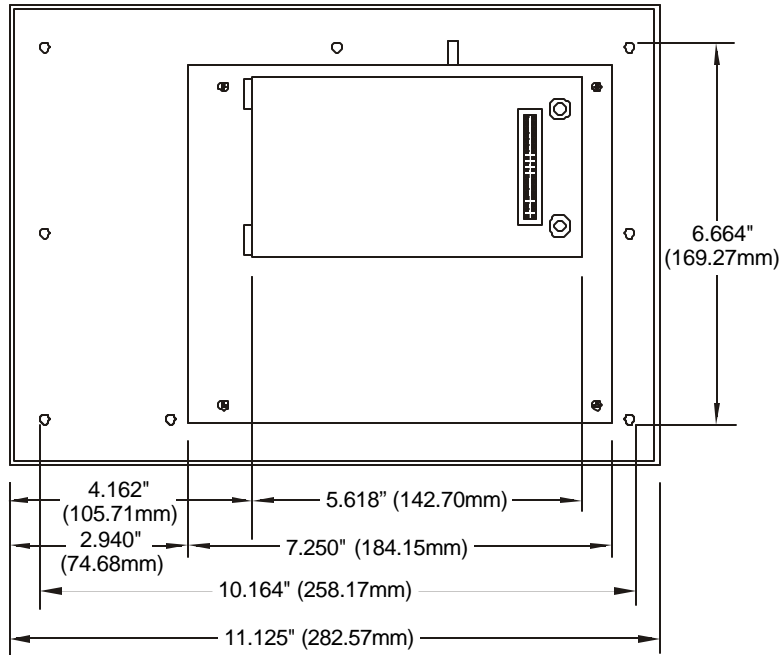
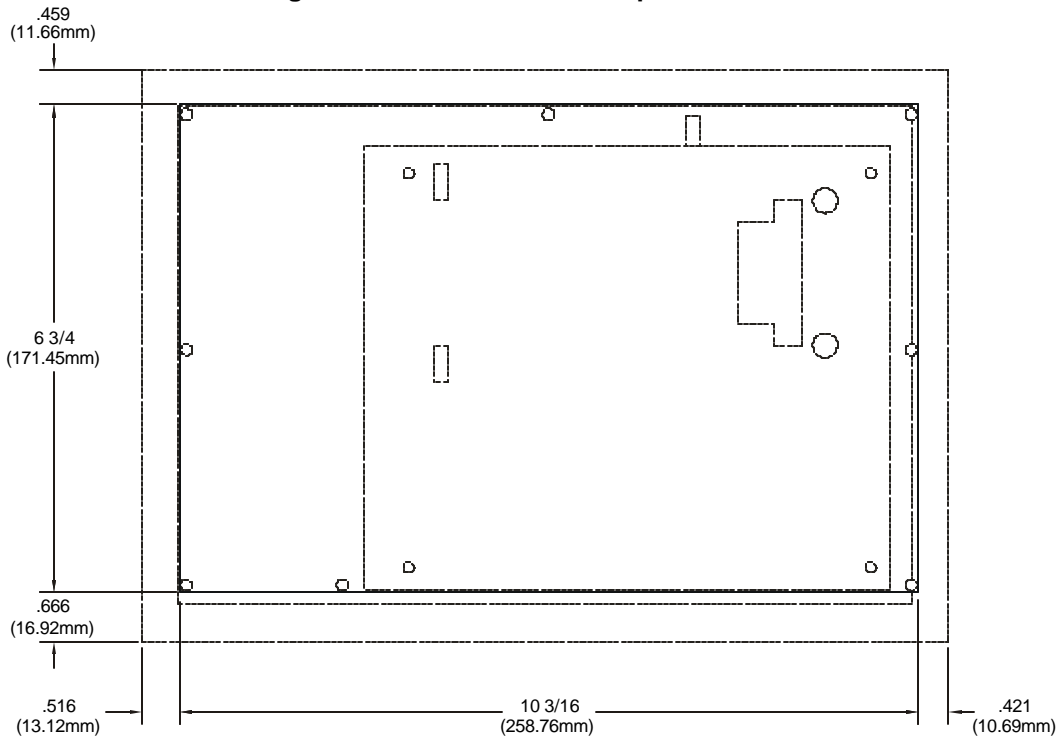

Figure 4.3 – Side View of Graphic OCS (Shown with four SmartStack Modules)



OCS250-1

Figure 4.4 – Back View of Graphic OCS



PANEL CUT-OUT DIMENSIONS FOR OCS250 (W/ MOUNTING SCREWS)
(OCS250 SHOWN FROM REAR VIEW)

Figure 4.5 – Panel Cutout of Graphic OCS

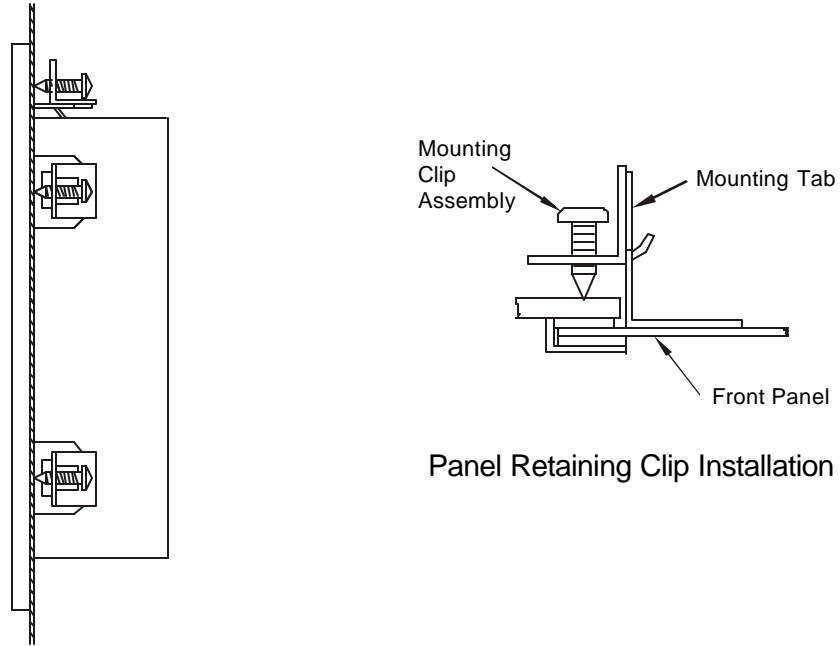

Figure 4.6a – Using Panel Retaining Clip (For applicable models)

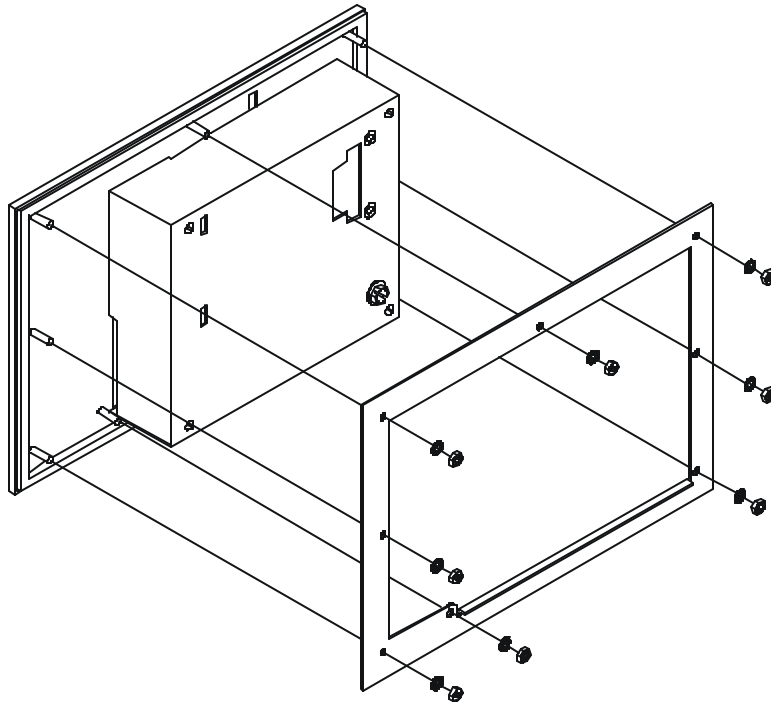

Figure 4.6b – Using Panel Mounting Clamp

4.3 Battery Replacement for the Graphic OCS (OCS250) (HE500BAT005)

To replace the battery, refer to the following steps and Figure 4.7. Use only the authorized battery part number shown above.

1. Disconnect power from the OCS unit
2. Remove ground screw (item #1) from back of the OCS unit. (Note: Some units may not be equipped with this style grounding.)
3. Remove all I/O modules from the back of the OCS.
4. Remove four (4) 6-32 pan head screws (item #2) and slide back cover (item #3) away from the unit. Once the CPU board is exposed locate the battery (item #4, U6). Remove the battery by prying up slightly on each end until it lifts free. Dispose of the battery.

Warning: Disposal of lithium batteries must be done in accordance with federal, state, and local regulations. Be sure to consult with the appropriate regulatory agencies *before* disposing batteries.

In addition, do not re-charge, disassemble, heat or incinerate lithium batteries.

5. Replace the battery with HE500BAT005 noting the polarity tab at one end of the battery. Use care when replacing the battery that this tab is located in the right direction. Use only the authorized battery part number shown above.

Warning: Do not make substitutions for the battery. Be sure to only use the authorized part number to replace the battery.

6. Reassemble the OCS unit by replacing the back cover and reinstalling the four 6-32 screws. Reattach the ground wire and reinstall the I/O modules. Follow the instructions in the units' manual for powering up the OCS and restoring it to operation.

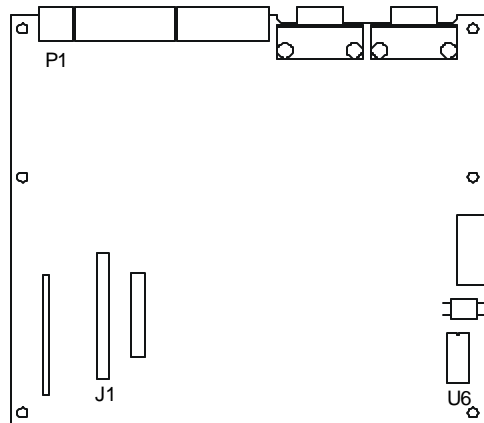

Figure 4.7 – Battery Replacement for the Graphic OCS

NOTES

CHAPTER 5: REMOTE CONTROL STATION (RCS)

5.1 General

Installation information is covered in Chapter Two that applies to one or more models of the OCS or the RCS. Product-specific information is covered in this chapter pertaining to the RCS. Examples of product-specific information includes:

- a. Mounting orientation and instructions
- b. Dimensions and panel cut-outs
- c. Some types of connectors and other hardware

Note: It is important to consult both this chapter and Chapter Two for installation information.

5.2 Mounting Orientation

The base of the RCS need to be mounted with the proper orientation. Proper orientation helps to ensure a good connection when SmartStack Modules are installed. Up to four SmartStack Modules can be locally installed per RCS. The RCS is installed inside a panel box.

Caution: Do not install more than four SmartStack Modules per RCS. Improper operation or damage to the RCS and SmartStack Modules can result.

Expansion: In addition to local I/O modules, up to 20 SmartStack I/O Modules can be connected to an OCS or RCS using five Fiber Optic Bases (FOX104 / 404), which each contain four I/O slots. If an expanded I/O connection is desired, the SmartStack FOX100 / 110 module must occupy the local OCS110 / 210/ 250 / or RCS250 Slot 1 position. See Chapter 9 and 10.

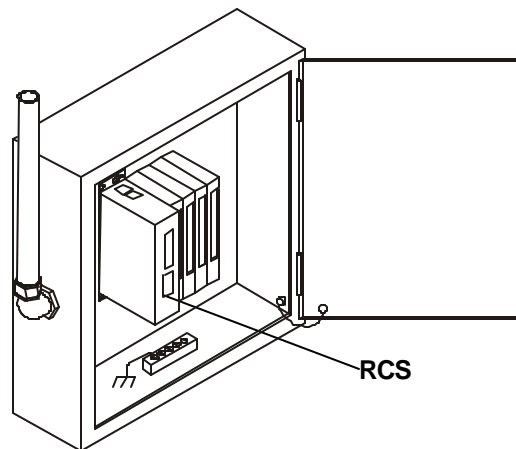
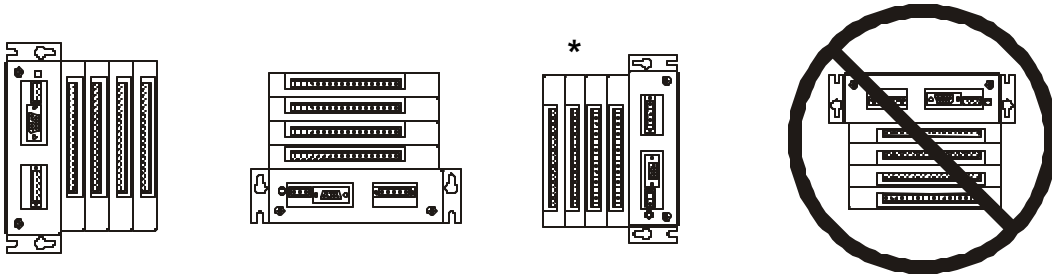

Figure 5.1 – RCS Orientation



* **Note:** The pin connector labeling on the RCS is upside-down if the base of the device is installed as shown in the third view.

Figure 5.2 – RCS Orientation (Shown with four SmartStack Options)

5.3 Mounting Instructions

The RCS is designed for permanent panel mounting. An optional mounting bracket is available for use.

To install the RCS in a permanent panel mounting, use the instructions that follow:

1. Read Chapter Two prior to mounting the RCS. Observe requirements for the panel layout design and adequate clearances. A checklist is provided for the user's convenience in Section 2.2.1
2. Drill holes. (Refer to Figures 5.4 – 5.6.)

Warning: Make sure the power and network connectors are removed from the OCS.

3. Install and tighten washers and nuts. Do not over-tighten.
4. Connect the communications and power cables to the RCS ports using the provided connectors.
5. Install up to four SmartStack Modules in the RCS.

5.4 RCS Optional Mounting Bracket (HE800ACC210)

The optional mounting bracket is used with SmartStack Modules that have connectors located on two sides. (Note that many SmartStack Modules only have connectors on one side.) Figure 5.3 depicts how to mount the bracket to an RCS.

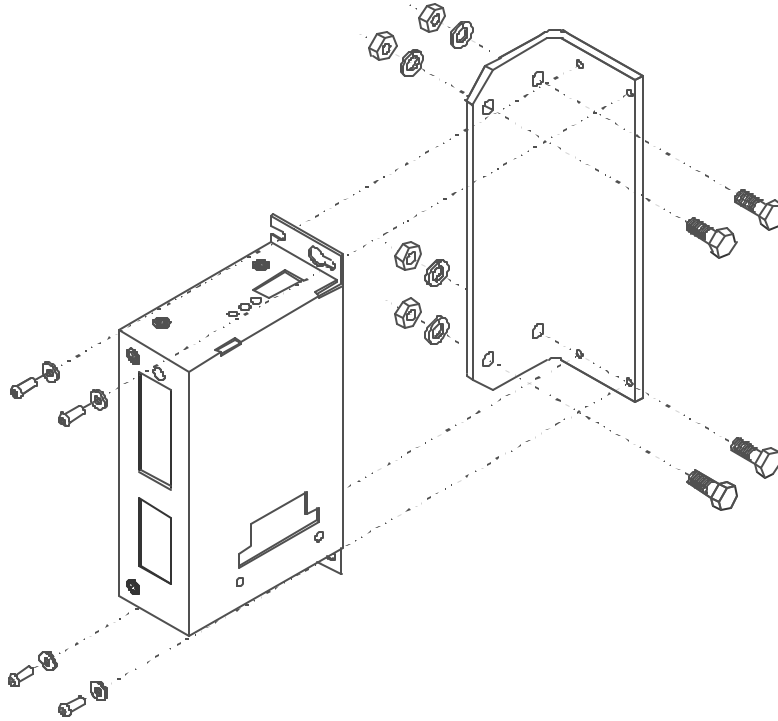
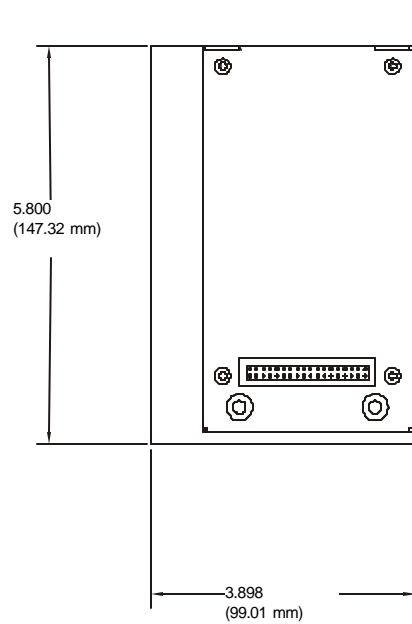
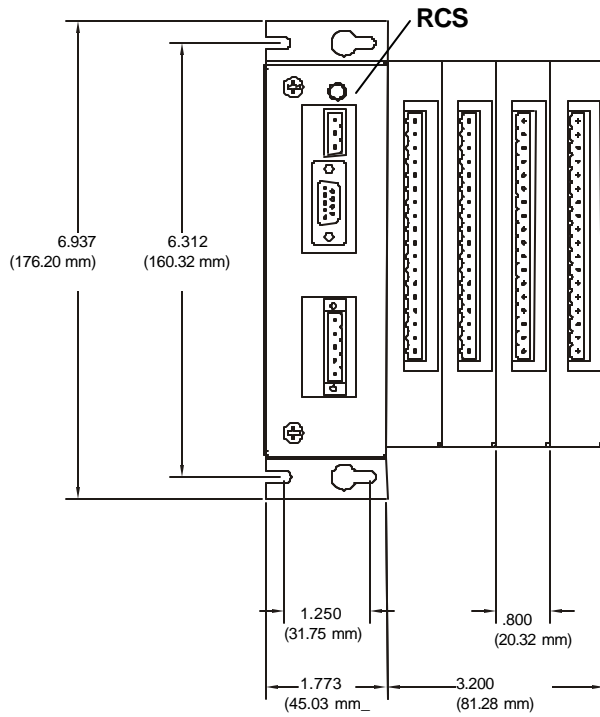

Figure 5.3 – Optional Mounting Bracket for Use with the RCS.

5.5 Dimensions and Panel Cut-Out



NOTE: Use #8-32 mounting hardware consisting of four 8-32 pan head screws with external tooth lock washers.

Figure 5.4 - Front View of the RCS
(Includes Four SmartStack[™] Modules & Dimensions)

Figure 5.5 - Side View of the RCS

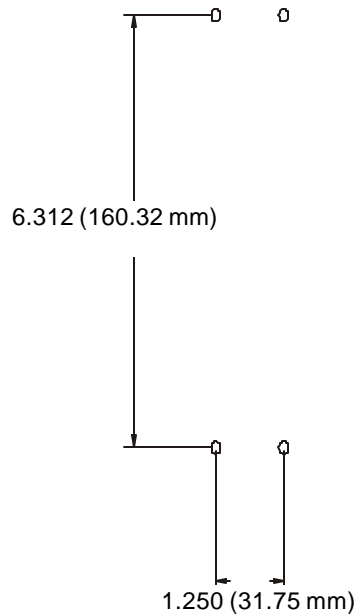

Figure 5.6 - Panel Cut-out for the RCS

5.6 Connectors

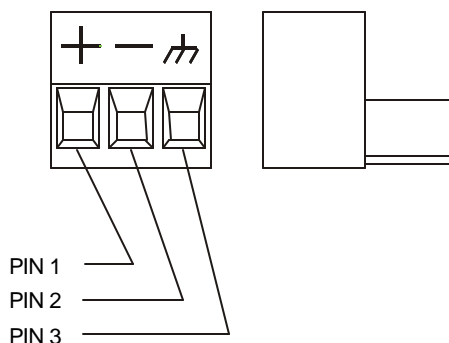
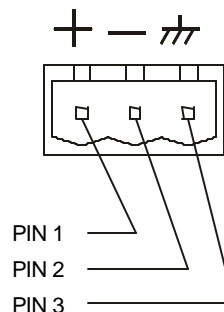

Figure 5.7 - RCS Power Connector

Figure 5.8 - RCS Power Connector looking at the RCS
(Front and Side Views Shown)

Note: Power Supply Voltage Range is from 10-30 VDC.

5.5 Battery Replacement for the RCS (HE500BAT005)

To replace the battery, refer to the following steps and Figure 5.9.

1. Disconnect power from the RCS unit.
2. Remove eight (8) 6-32 screws (item #1) and remove back cover (item #2).
3. Once the CPU board is exposed locate the battery (item #3, U6). Remove the battery by prying up slightly on each end until it lifts free. Dispose of the battery.
4. Replace the battery with HE500BAT005 noting the polarity tab at one end of the battery. Use care when replacing the battery that this tab is located in the right direction. Use only this authorized battery part number.

Warning: Do not make substitutions for the battery. Be sure to only use the authorized part number to replace the battery.

Warning: Disposal of lithium batteries must be done in accordance with federal, state, and local regulations. Be sure to consult with the appropriate regulatory agencies *before* disposing batteries.

In addition, do not re-charge, disassemble, heat or incinerate lithium batteries.

5. Reassemble the RCS unit by replacing the back cover and reinstalling the eight 6-32 screws. Follow the instructions in the unit's manual for powering up the RCS and restoring it to operation.

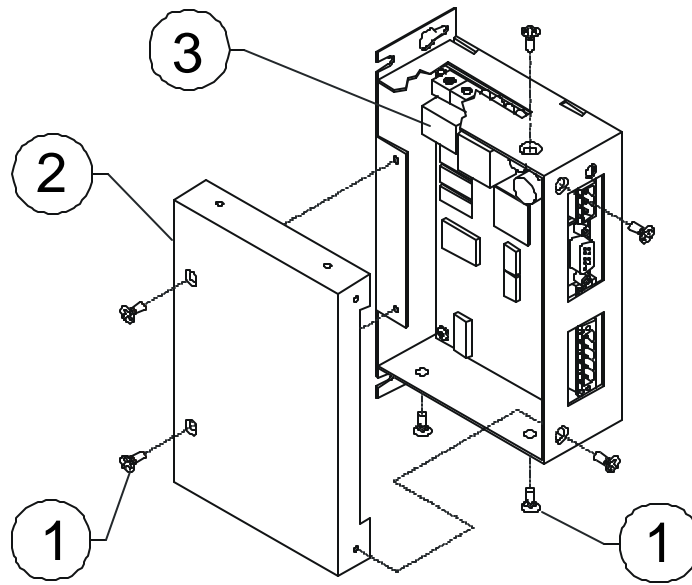

Figure 5.9 – Battery Replacement for the RCS210

CHAPTER 6: OCS / RCS CONFIGURATION (SYSTEM MENU)

6.1 General

Chapter Six describes the System Menu.

The System Menu is used to access and edit information using the OCS front panel or using the **Remote Text Terminal**, which is a feature available in both the OCS/RCS. The Remote Text Terminal is required when using the RCS, because the RCS does not have a physical front panel display screen or keypad. For more information, see Section 7.1.

The following list contains examples of parameters that can be set using the System Menu:

- Network ID
- Network Baud
- RS232 Mode
- Time/Date
- LCD contrast
- Fkeys mode

6.2 Navigating Through the System Menu

Prior to configuration, it is important to know how to navigate through the System Menu using the following guidelines.

1. Pressing the \uparrow and \downarrow keys scroll up or down through the menu options.
2. Pressing the **Enter** key selects the system screen that the indicator arrow is pointing to.
3. Once in a system screen, press **ESC** (if not currently modifying a field) to return to the main System Menu.

6.3 Editing System Menu Screen Fields

Prior to configuration, it is important to know how to edit the System Menu screen fields using the following guidelines.

1. Some fields in the system screens are editable; others are not editable. The OCS1xx and OCS2xx models indicate an editable field with a solid cursor ($_$) under the first character in the field. The exception to this is the OCS250.
2. To change a value in an editable field, press the **Enter** key to select edit mode. The OCS1xx and OCS2xx models indicate edit mode by displaying a flashing block cursor. For the OCS250, the edit mode is indicated when a value is highlighted.
3. In edit mode, the fields require one of the following methods for modifying the value. Refer to the field description to determine which method to use.
 - Enumerated entry - use \uparrow and \downarrow keys to select appropriate value.
 - Numeric entry - use Numeric keys or \uparrow and \downarrow keys on the appropriate digit.
 - Bar graph entry - use \leftarrow and \rightarrow keys to adjust value.
4. After the value is correctly entered, press the **Enter** key to accept the value.
5. If the user does not wish to accept the value before the **Enter** key is pressed, the **ESC** key can be pressed instead. This action restores the original value to the display. The OCS/RCS model also immediately exits edit mode; however, the Text models (except the Graphic OCS250) remain in edit mode with the original value and requires the **Enter** key to be pressed to exit.

6.4 Remote Screen / Keypad (Using Remote Text Terminal and Status Bar)

The RCS has the same functionality as the OCS except that it does not have a local operator screen and keypad. However, the RCS (as well as the OCS) supports a remote operator screen and keypad through a PC connected to the OCS/RCS unit's built-in network or serial port. If desired, the remote operator interface and keypad can be displayed (using Cscape software) by pressing **Screens, Remote Text Terminal**. A virtual display screen and keypad appear that are similar to that of the OCS, and the user can navigate through the system menu, make selections, and edit fields using a mouse. In addition, the **Cscape Status Bar** can be used as a tool to ensure that communications are properly established. **For more information on the Remote Text Terminal and the Cscape Status Bar feature, see Section 7.1.**

6.5 Initial System Menu Screens and Self-Test

Note: The examples in this chapter depict the OCS, but the information also applies to the RCS when using the Remote Text Terminal screen. (Refer to Section 6.4.)

1. After turning on the power to the OCS, the following screen appears which indicates the product (xxx is the model number) and the network it is connected to. It also indicates that the Self-Test is running.
(This screen does not appear when using the Remote Text Terminal.)

```
OCSxxx- CsCAN  
Self-Test Running
```

- a. If the Self-Test passes, the following screen appears:

```
** Self-Test **  
**** Passed ****
```

- b. If the Self-Test fails, see **View OCS(RCS) Diags** in Section 6.7.

6.6 Entering the System Menu

- a. To enter the System Menu on the OCS1xx or the Graphic OCS250 using the **local** keypad, press both the ↑ and ↓ keys at the same time. Notice that the two keys are surrounded by a white outline and the word "System" on the silkscreen of the keypad. For the OCS2xx, simply press the System Key
- b. Again, if using the RCS, refer to Section 7.1 in its entirety to use the **Remote Text Terminal** and create a virtual keypad and screen. Be sure to follow the procedures to establish and verify proper communications (Section 7.1.3). After doing so, the following menu options can be accessed by clicking the specified key in the display representation using a mouse.

6.7 System Menu Option Screens

In addition to providing access to the OCS/RCS, configuration parameters, the System Menu also provides power-up and runtime status. For brevity, both configuration and status fields are covered in this section

There are up to ten different menu options which include the following:

- Set Network ID
- Set Network Baud
- Set Contrast
- View OCS(RCS) Status
- View OCS(RCS) Diags
- View I/O Slots
- Set Fkeys Mode
- Set RS232 Mode.
- Set Time/Date

- **Set Network ID**

This screen contains two fields. The first field contains the current network status. The second field contains the current Network ID of the model. The second field is numerically editable and is used to configure the Network ID.

Each unit on the network **needs a unique ID number**. Enter the correct ID number before physically attaching the unit to the network.

Cscan model: [1 - 253]
DeviceNet model: [0 - 63]

Note: If the Network ID setting is changed, the unit stops executing the ladder code (for up to 1 second) while the network is re-tested. If the "Network OK?" status changes from "Yes" to "No," the new Network ID is a duplicate, and another ID needs to be selected.

- **Set Network Baud**

This screen contains an editable enumerated field allowing the user to select the current baud rate of the network.

Cscan model: [125K, 250K, 500K, 1M]
DeviceNet model: [125K, 250K, 500K]

Note: All devices on the network must be at the same baud rate. A device configured for the wrong baud rate may shut down the network entirely.

- **Set Contrast**

This menu contains an editable bar graph entry allowing the user to set the contrast of the LCD display.

- **View OCS (RCS) Status**

This screen contains both a single enumerated editable field that sets the OCS/RCS scan mode and status fields that display information about the internal state of the OCS/RCS. Pressing the ↑ and ↓ keys scrolls through the different items. Pressing **Esc** returns to the System Menu.

<u>Parameter</u>	<u>Description</u>
------------------	--------------------

Model	Displays the OCS/RCS model number such as OCS110, OCS210, etc.
--------------	--

OCS Mode	Displays the current scanning mode (Idle , Run , DoIO). In <i>Idle</i> mode, the I/O is <u>not</u> scanned and the OCS ladder program does <u>not</u> execute. The green "RUN" LED is OFF. In <i>Run</i> mode, the ladder program executes and the green "RUN" LED illuminates. <i>DoIO</i> mode is similar to <i>Run</i> mode, except the ladder logic is not solved. When the OCS is in <i>DoIO</i> mode, the user is able to exercise all of the I/O from Cscape, without interference from the ladder program. In this mode the green "RUN" LED flashes. This feature is a valuable troubleshooting tool.
-----------------	--

Scan-Rate	Shows the number of milliseconds for the scan. The scan-rate is the sum of the time required to execute the following items:
------------------	--

- a. Scan inputs
- b. Solve logic
- c. Write outputs
- d. Handle network communications
- e. Handle host communications request
- f. Process data for operator interface

OCS Net Use	Shows the percentage of the network bandwidth used by the OCS/RCS.
--------------------	--

All Net Use	Shows the percentage of the network bandwidth used by all devices on the network.
--------------------	---

Ladder Size	Shows the number of bytes used by the ladder program.
--------------------	---

Config Size	Shows the number of bytes used by the I/O configuration
--------------------	---

(Text Models)

Text Size	Shows the number of bytes used by the text screens
------------------	--

(OCS250 Model Only)

Graphics Size	Shows the number of bytes used by the graphical objects.
----------------------	--

String Size	Shows the number of bytes used by Legend and State strings.
--------------------	---

Bitmap Size	Shows the number of bytes used by bitmaps.
--------------------	--

Text Tbl Size	Shows the number of bytes used by text tables.
----------------------	--

Font Tbl Size	Shows the number of bytes used by the font table.
----------------------	---

Firmware Rev	Shows the execution engine firmware version.
---------------------	--

BIOS Rev	Shows the BIOS firmware revision.
-----------------	-----------------------------------

FPGA Rev	Shows the FPGA Image version.
-----------------	-------------------------------

Self-Test	Shows if the power-up self-test passed or failed by displaying Ok or Fault .
------------------	--

- **View OCS(RCS) Diags**

This screen displays a list of self-test diagnostics results (no editable fields). Each item describes a test and shows a result of **Ok** if the test passed or **Fault/Warn** if an error was found while running the test. **Fault** indications will prevent the loaded application from running. **Warn(ing)** indications allow the application to run but inform the user that a condition exists that needs correction.

System BIOS - This test checks for a valid BIOS portion of the controller firmware.

- Ok** The loaded BIOS firmware is valid
- Fault** The loaded BIOS is invalid.

(Engine) Firmware - This test validates the controller firmware.

- Ok** The firmware is valid.
- Fault** The controller firmware is invalid.

User Program - This tests for a valid user program and configuration data.

- Ok** The user program and configuration is valid.
- Fault** The user program and/or configuration are not valid.

System RAM - This test checks the functionality of the controller RAM at power up.

- Ok** The RAM is functioning correctly.
- Fault** The RAM is not functioning correctly.

Logic Error - This test checks for problems with the user program while running.

- Ok** No errors have been encountered while running a user program.
- Fault** Indicates the user program contained an instruction that was invalid or unsupported.

W-Dog Trips - This test checks for resets caused by hardware faults, power brownouts or large amounts of electrical interference.

- 0** No unintentional resets have occurred.
- xx** Indicates a fault with xx showing the number of occurrences.

Net Errors - This test checks for abnormal network operations while running. (Network models only.)

- 0** No network errors were counted
- xx** Indicate serious networking problems exist, xx indicates the number of occurrences.

Network State - This test checks that the network sub-system is powered and operating correctly. (Network models only.)

- Ok** The network system is receiving power and has determined other devices are communicating on the network.
- Warn** Power is not being applied to the network or no other devices were found to be communicating on the network.

Network ID - This test checks that the network ID is valid. (Network models only.)

- Ok** The network ID is valid.
- Warn** The network ID is not valid for the selected protocol.

Dup Net ID - This test checks for duplicate IDs on a network. (Network models only.)

- Ok** This controller's ID was not found to be a duplicate.
- Warn** Another controller on the network was found with the same ID as this controller.

DeviceNet In - (DeviceNet model only.)

Ok DeviceNet master is maintaining a polled connection and not sending IDLE.

Warn The DeviceNet master is no longer maintaining a polled connection or sending IDLE. (IDLE is a network state in which 'some' masters maintain a polled connection but sends zero data if an associated PLC controller is in IDLE mode. Refer to Master documentation for more information.)

Clock Error - This test checks that the real time clock contains valid data.

Ok The real time clock contains valid data.

Warn Indicates invalid data in the real time clock.

I/O System - This test checks that the I/O configuration downloaded and the physical devices (SmartStack) attached to the controller match.

Ok The I/O configuration matched the installed modules.

Warn Indicates the downloaded configuration and attached modules do not match. (See View I/O Slot system screen for more information.)

- **View I/O Slots**

The View I/O Slots screen displays information about SmartStack modules (if any) that are currently connected to the OCS or RCS. Some models (**OCS110 / 210, OCS250, and RCS250**) support multiple I/O bases using a FOX (Fiber Optic eXpansion) interface. For these models, the View I/O Slots screen also allows selection of the I/O base to be displayed and indicates whether the I/O base is online, offline, or duplicated.

When viewing I/O slots, the following status screens are possible. Note that in the I/O slot display descriptions, the term **ModNum** refers to a SmartStack I/O module number such as DIQ611 or THM100.

- a. If an OCS slot has no configured I/O module and no module is physically attached, the message "**I/O: Empty**" is displayed for the appropriate slot.
- b. If an OCS slot has no configured I/O module and a module is physically attached, the message "**+I/O: ModNum**" is displayed for the appropriate slot.
- c. If an OCS slot has a configured I/O module and no module is physically attached, the message "**-I/O Missing**" is displayed for the appropriate slot.
- d. If an OCS slot is configured for a different module than what is physically attached, the message "**?I/O: ModNum**" is displayed for the appropriate slot.
- e. If an attached module is not supported by the OCS firmware, the message "***Unsupported**" is displayed for the appropriate slot. The module is either defective or an Engine firmware upgrade is required to support the module.
- f. If an attached I/O module has erroneous or outdated firmware in it, the message "**fI/O: ModNum**" is displayed for the appropriate slot. The module is either defective or a Module firmware upgrade is required.
- g. If an attached module has a configuration error, the message "**clI/O: ModNum**" is displayed for the appropriate slot. The configuration data for that module is incorrect.
- h. If an OCS slot configuration matches the attached I/O module, the message "**I/O: ModNum**" is displayed for the appropriate slot.

- **Set FKeys Mode**

This screen contains an editable enumerated field that allows the Function keys to be configured to operate in one of two modes. When a function key is pressed, it can TOGGLE the point associated with the key or it can MOMENTARILY turn the point ON when the key is pressed.

- **Set RS232 Mode**

This screen contains an editable enumerated field that allows the mode of the serial port to be set to one of two modes. The **CsCAN** mode allows Cscape to connect to the serial port for uploads, downloads, monitoring and control. The **Update** mode allows a firmware update and factory test utility to be used. When Update mode is selected, the firmware is ready to download when the OK LED flashes. When using Cscape to perform firmware updates, manual selection of "Update" mode is not necessary.

- **Set Time/Date**

This screen contains two editable enumerated fields for displaying and modifying the OCS/RCS's time and date. Each field is subdivided and allows the ↑ and ↓ key to modify the value.

6.7 Setting RCS Network ID

Since the RCS does not have a screen or keypad, the Network ID is set by using switches located on the RCS.

- **Setting CsCAN Network IDs: (Refer to Conversion Table 6.1)**

CsCAN Network IDs are set on the RCS using the hexadecimal number system from 01 to FD. (The decimal equivalent is 01-253.)

- **Setting DeviceNet Network IDs (MAC ID)**

DeviceNet Network MAC IDs are set on the RCS using the decimal number system (0-63).

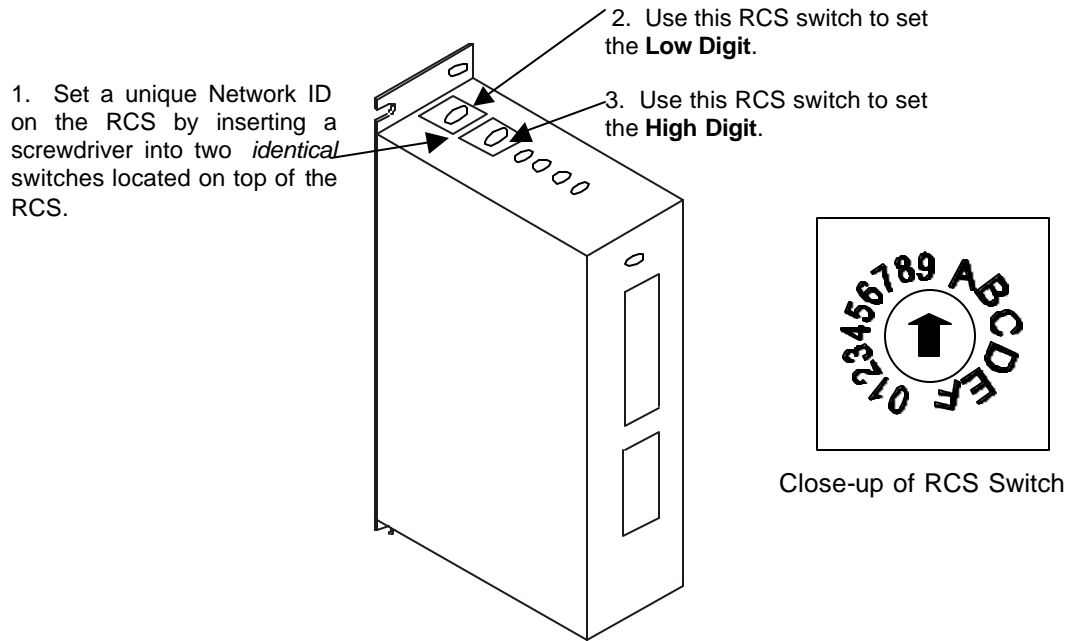

Figure 6.1 – Setting Network ID using RCS Switches

Table 6.1 shows the decimal equivalent of hexadecimal numbers. Refer to the table when setting Network IDs for RCS devices used in CsCAN networks.

Table 6.1 – Hexadecimal (H) to Decimal (D) Conversion Table															
H	D	H	D	H	D	H	D	H	D	H	D	H	D	H	D
00	0	20	32	40	64	60	96	80	128	A0	160	C0	192	E0	224
01	1	21	33	41	65	61	97	81	129	A1	161	C1	193	E1	225
02	2	22	34	42	66	62	98	82	130	A2	162	C2	194	E2	226
03	3	23	35	43	67	63	99	83	131	A3	163	C3	195	E3	227
04	4	24	36	44	68	64	100	84	132	A4	164	C4	196	E4	228
05	5	25	37	45	69	65	101	85	133	A5	165	C5	197	E5	229
06	6	26	38	46	70	66	102	86	134	A6	166	C6	198	E6	230
07	7	27	39	47	71	67	103	87	135	A7	167	C7	199	E7	231
08	8	28	40	48	72	68	104	88	136	A8	168	C8	200	E8	232
09	9	29	41	49	73	69	105	89	137	A9	169	C9	201	E9	233
0A	10	2A	42	4A	74	6A	106	8A	138	AA	170	CA	202	EA	234
0B	11	2B	43	4B	75	6B	107	8B	139	AB	171	CB	203	EB	235
0C	12	2C	44	4C	76	6C	108	8C	140	AC	172	CC	204	EC	236
0D	13	2D	45	4D	77	6D	109	8D	141	AD	173	CD	205	ED	237
0E	14	2E	46	4E	78	6E	110	8E	142	AE	174	CE	206	EE	238
0F	15	2F	47	4F	79	6F	111	8F	143	AF	175	CF	207	EF	239
10	16	30	48	50	80	70	112	90	144	B0	176	D0	208	F0	240
11	17	31	49	51	81	71	113	91	145	B1	177	D1	209	F1	241
12	18	32	50	52	82	72	114	92	146	B2	178	D2	210	F2	242
13	19	33	51	53	83	73	115	93	147	B3	179	D3	211	F3	243
14	20	34	52	54	84	74	116	94	148	B4	180	D4	212	F4	244
15	21	35	53	55	85	75	117	95	149	B5	181	D5	213	F5	245
16	22	36	54	56	86	76	118	96	150	B6	182	D6	214	F6	246
17	23	37	55	57	87	77	119	97	151	B7	183	D7	215	F7	247
18	24	38	56	58	88	78	120	98	152	B8	184	D8	216	F8	248
19	25	39	57	59	89	79	121	99	153	B9	185	D9	217	F9	249
1A	26	3A	58	5A	90	7A	122	9A	154	BA	186	DA	218	FA	250
1B	27	3B	59	5B	91	7B	123	9B	155	BB	187	DB	219	FB	251
1C	28	3C	60	5C	92	7C	124	9C	156	BC	188	DC	220	FC	252
1D	29	3D	61	5D	93	7D	125	9D	157	BD	189	DD	221	FD	253
1E	30	3E	62	5E	94	7E	126	9E	158	BE	190	DE	222	FE	254
1F	31	3F	63	5F	95	7F	127	9F	159	BF	191	DF	223	FF	255

NOTES

CHAPTER 7: KEYPAD AND SCREEN

7.1 Remote Screen and Keypad Capability

7.1.1 Remote Text Terminal

The RCS has the same functionality as the OCS except that it does not have a local operator screen and keypad. However, the RCS (as well as the OCS) supports a remote operator screen and keypad through a PC connected to the RCS unit's built-in network or serial port. The remote operator interface and keypad can be displayed using Cscape software by pressing **Screens, Remote Text Terminal**. A virtual display screen and keypad appear that are similar to the OCS's physical front panel, and the user can navigate through various screens, make selections, and edit fields using a mouse.

7.1.2 Cscape Status Bar

When the OCS/ RCS is connected to a PC using Cscape software, *and* the Remote Text Terminal feature is selected, a Cscape Status Bar appears at the bottom of the screen. The Cscape Status Bar can be used to determine if communications have been established between the OCS/RCS and the Cscape program. Components of the Cscape Status Bar are explained in Figure 7.1.

Message Line -

The contents of these messages are context sensitive. The Message line can be empty.

Equal Indicator – indicates whether the current program in Cscape is equal to the program stored in the Target Controller.

- If **Equal**, the program in Cscape is the same as the program stored in the Target Controller.
- If **Not Equal**, the program in Cscape is not the same as the program stored in the Target Controller.
- If **Unknown**, there may have been a change since the last time the program in Cscape was compared to the Target Controller.

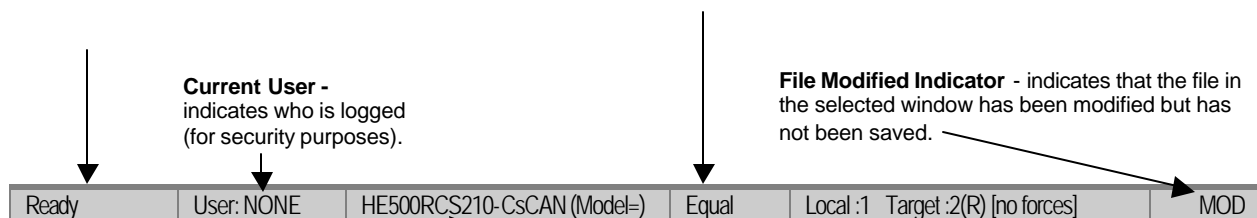

Controller Model - Network (Model Confirmation)

- **Controller Model** indicates the OCS or RCS for which the program in Cscape is configured.
- **Network** indicates the type of network that the program in Cscape expects to use (e.g., CsCAN or DeviceNet).
- **(Model Confirmation)** provides the following indications:
 - **(Model=)** - the actual Target Controller matches the configured Controller Model and Network.
 - **(Model Not=)** – the actual Target Controller does not match the configured Controller Model and Network.
 - **(Model ?)** – there may have been a change since the last time the Target Controller was compared to the configured Controller Model and Network.

Communications Status - indicates the current status of the "pass through" Connector.

- **Local: xx** – indicates the Network ID of the OCS/RCS to which the Cscape program is physically connected through its serial port. It can serve as a "pass through" device to other nodes on the network.
- **Target: yy(R)** – indicates the Network ID of the OCS/RCS with which the Cscape program is exchanging data.
Note: The **Local** unit and **Target** unit can be the same unit or they can be separate units.

The following are status indicators:

- (R) – Running
- (D) - Do I/O
- (I) – Idle
- (?) – Cscape is not communicating with the remote unit.
- [no forces] – indicates no I/O has been forced.

7.1.3 *Establishing Communications using the Remote Text Terminal*

1. Start Cscape software. Press **Screens, Remote Text Terminal**.
2. Establish communications between the Cscape program and OCS/RCS by pressing **Controller, Set Network Target ID**. Set the Target ID.
3. Again, select **Controller, Configure I/O**. Follow the procedures specified in Chapter 8: I/O Configuration.
4. Download the program from Cscape to the OCS/RCS by pressing **Program, Download**.
5. Check the **Cscape Status Bar** as described in Section 7.1.2 to ensure that the program in Cscape matches the program downloaded to the OCS/RCS. Be sure to check the Status Bar often. Another way to check that the download occurred is to press **Program, Verify**.
6. Click on the **System Key** in the display representation and continue the procedures to enter the system menu described in Chapter Six.

7.2 **OCS1XX Description**

When the OCS1XX unit first powers-up, it displays **OCS1XX-CsCAN Self-Test Running**. After the OCS displays this message, the unit performs tests to examine the current state of the network. At any time, the OCS unit can be reset by pressing: ↑ + F1 + F2 (press the keys at the same time).

The OCS1XX keypad contains 10 user-programmable keys, **Shift, Esc, Enter** and four direction keys.

The user-programmable keys, or function keys, also serve the purpose of numeric and alphabetic character entry. Function keys **F1-F10** are available (%K registers). The standard OCS1XX insert (removable) has printing on both sides. One side has split field keys that contain the function key number in one field and a digit from 0-9 in the other field (as shown by the following diagram).

The other side of the insert has a split field that contains the function key in one field and digits from 0-9 and alphabetic characters in the other field (not shown). It is up to the user to decide which side of the insert they want displayed (the latter side is standard). Depending on the configuration of the OCS1XX and the field needing to be edited, the OCS “automatically knows” what type of digit or alphanumeric character needs to be entered. There is **no need** to press the **Shift** key and then the corresponding digit or alphanumeric character.

The OCS1XX keypad also contains four direction keys. The ↑ and ↓ keys contain split fields. The ↑ key also contains the +/– function. The ↓ key also contains the . function. Similar to the operation of the function keys, the OCS1XX “automatically knows” if a decimal point or a positive or negative indicator is required. There is **no need** to press the **Shift** key. The ↑ and ↓ keys are also used to increment and decrement fields, respectively. The ← and → keys are used to move the cursor from one character to another in an editable field and to switch from one editable field to another editable field.

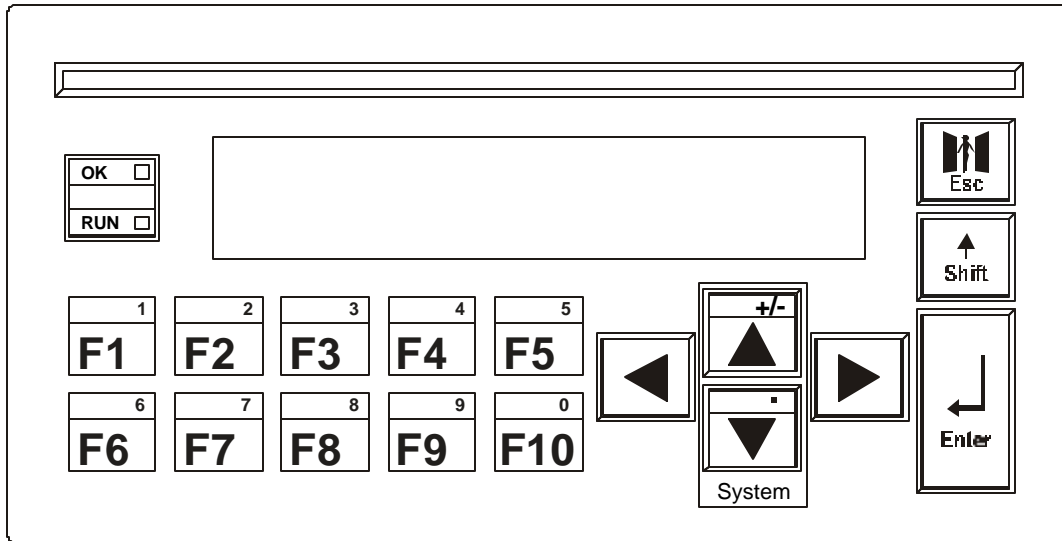

Figure 7.1- OCS1XX Keypad

The OCS1XX features an **Esc**, a **Shift** and an **Enter** key. The **Esc** key is used to exit out of a number of different menus and fields or abort an editing operation. The **Enter** key is used to select a field for editing and for sending data to the OCS1XX. The **Enter** key can also be used to escape out of some selected fields. The **Shift** key is used to enter a space in an alphanumeric field.

The OCS1XX keypad has OK and RUN indicators. These indicators are green LEDs that are built into the keypad. When there are no errors present in the OCS1XX and the Self-Tests have passed, the green OK LED illuminates. When the controller is running logic, the RUN LED illuminates. If the controller is in the RUN mode with no logic loaded or if it is in the DO I/O mode, the RUN LED flashes.

7.3 OCS2XX Description

When the OCS2XX unit first powers-up, it displays **OCS2XX-CsCAN Self-Test Running**. After the OCS displays this message, the unit performs tests to examine the current state of the network. At any time, the OCS unit can be reset by pressing: $\uparrow + F1 + F2$ (press the keys at the same time).

The OCS2XX keypad contains 12 user-programmable keys, **Shift**, **Esc**, **Enter**, four direction keys and a full numeric keypad. There are 12 keys. The 12 user-programmable keys are used as function keys only (%K registers). The inserts for the OCS2XX function keys are removable.

The OCS2XX keypad contains four direction keys. The \uparrow and \downarrow keys are also used to increment and decrement fields, respectively. The \leftarrow and \rightarrow keys are used to move the cursor from one character to another in an editable field and to switch from one editable field to another field.

The OCS2XX features an **Esc**, **Shift** and an **Enter** key. The **Esc** key is used to exit out of several different menus and fields or abort an editing operation. The **Enter** key is used to select a field for editing and for sending data to the OCS2XX. The **Enter** key can also be used to Escape out of some selected fields. The **Shift** key is used to enter a space in an alphanumeric field.

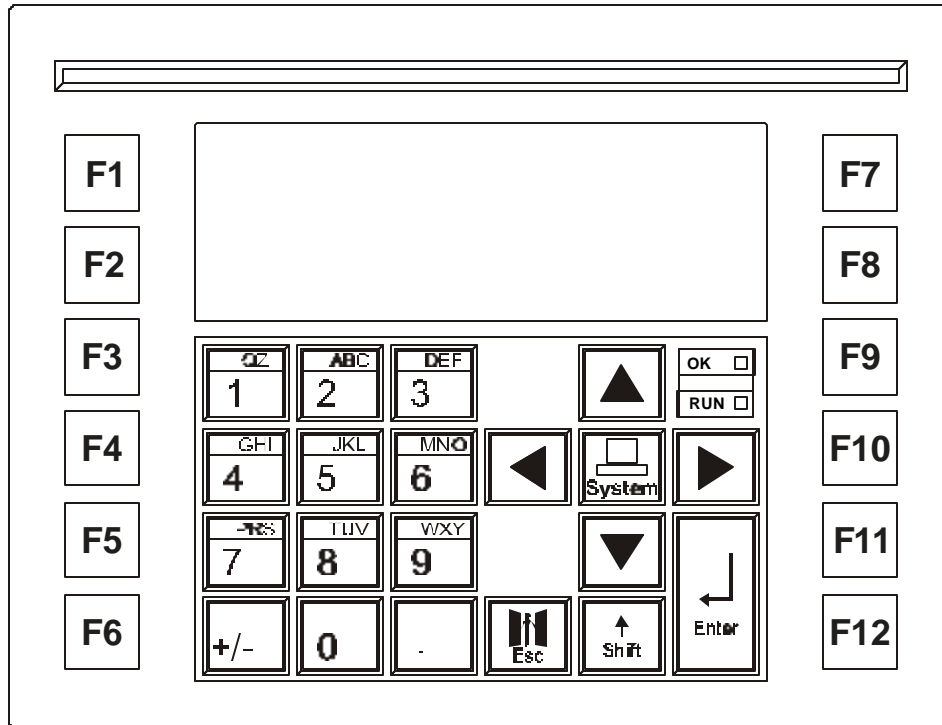

Figure 7.2 – OCS2XX Keypad

Unlike the OCS1XX keypad, the OCS2XX keypad contains a full numeric keypad. Numbers 0–9, +/- and . are available. The keys with numbers 0–9 have split fields with alphabetic characters. Depending on the configuration of the OCS2XX and the field needing to be edited, the OCS “automatically knows” what type of digit or alphanumeric character needs to be entered. There is no need to press the **Shift** key and then the corresponding digit or alphabetic character.

The OCS2XX keypad has OK and RUN indicators. The indicators are green LEDs that are built into the keypad. When there are no errors present in the OCS2XX and the Self-Tests have passed, the green OK LED illuminates. The RUN LED is off when the OCS is in idle mode; flashes when the OCS is in DO I/O mode and is on when the OCS is in RUN mode. Note that the RUN LED also flashes when the OCS is in the RUN mode if there is no ladder program loaded into the OCS.

7.4 Graphic OCS250 Description

The Graphic OCS250 keypad contains 10 user-programmable keys, **Esc**, **Enter**, four direction keys and a full numeric keypad. The 10 user-programmable keys are used as function keys only (%K registers). Each function key also has a user-programmable LED indicator associated with it. The inserts for the Graphic OCS250 function keys are removable. There are 12 numeric entry keys.

The Graphic OCS250 keypad contains four direction keys. The ↑ and ↓ keys are also used to increment and decrement fields, respectively. The ← ↑ and → ↓ keys are used to move the cursor from one character to another in an editable field and to switch from one editable field to another field.

The Graphic OCS250 features an **Esc** and an **Enter** key. The **Esc** key is used to exit out of several different menus and fields or abort an editing operation. The **Enter** key is used to select a field for editing and for sending data to the Graphic OCS250. The **Enter** key can also be used to escape out of some selected fields.

The Graphic OCS250 keypad contains a full numeric keypad. Numbers 0–9, +/- and . are available. The keys with numbers 0–9 have split fields with alphabetic characters. Depending on the configuration of the Graphic OCS250 and the field needing to be edited, the OCS “automatically knows” what type of digit or alphanumeric character needs to be entered. There is no need to press an alternate key and then the corresponding digit or alphabetic character.

The Graphic OCS250 keypad has OK and RUN indicators. The indicators are green LEDs that are built into the keypad. When there are no errors present in the Graphic OCS250 and the Self-Tests have passed, the green OK LED illuminates. The RUN LED is off when the OCS is in idle mode; flashes when the OCS is in DO I/O mode and is on when the OCS is in RUN mode. Note that the RUN LED also flashes when the OCS is in the RUN mode if there is no ladder program loaded into the OCS.

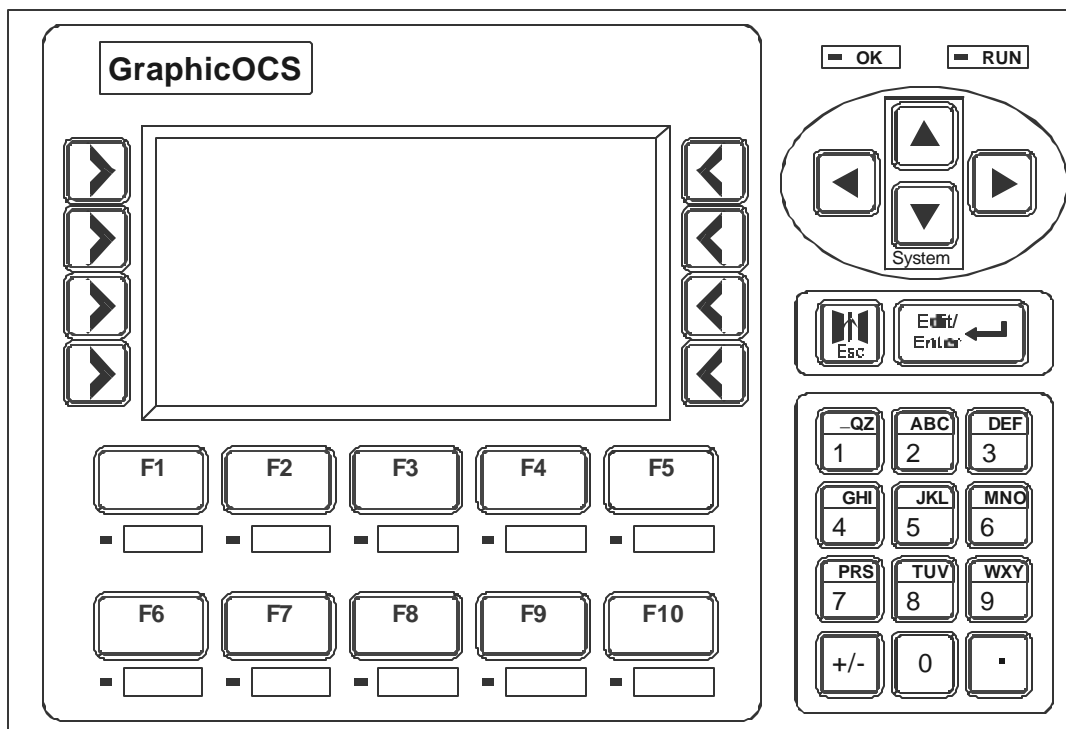

Figure 7.3 – OCS250 Keypad

7.5 User Screens

In the normal operating mode there are a set of user-defined screens that can be scrolled through using the ↑ and ↓ keys. The exception is the Graphic OCS250, which uses a screen jump object.

If the ladder program energizes a text coil, the screen associated with this coil is displayed and overrides the normal user screens. This is designed to show alarm conditions or to display other ladder-detected events. When the text coil is de-energized, the previous screen that was being viewed before the alarm is returned.

If the screen contains an editable field, the user can press the **Enter** key to enter the edit mode. When in edit mode, a cursor appears on one digit of the editable field. Use the direction keys (← and →) to move to the cursor to the desired position. Use the ↑ and ↓ keys to increment or decrement the digit or enter the number/data with the alphanumeric keys.

If there is more than one field on the screen needing to be edited, use the direction keys (← and →) to move the cursor to the desired location.

The value chosen by the user can not exceed the minimum or maximum set by the user program. If the user tries to exceed the maximum point or enter a value below the minimum point, the value does not change.

Note: If the OCS displays >>>>> in a text field, the value is too big to display in the field or is above the maximum for an editable field. If the OCS displays <<<< in a text field, the value is too small to display or is below the minimum for an editable field.

7.5.1 Cursor Types (Does Not Apply to Graphic OCS250)

There are three different cursor types which may show on the display:

- a. Solid underline
- b. Blinking block
- c. Blinking underline

A *solid underline cursor* appears under an editable field which is not being edited yet. The ← key and the → key can be used to move this type of cursor to select a different editable field, if required. Press **Enter** to start editing the selected field. This causes a *blinking block cursor* to appear.

A *blinking block cursor* appears in an editable field when **Enter** is first pressed to start editing the field. The *blinking block cursor* indicates that the field will be cleared when a numeric (or alphanumeric for an ASCII field) key is pressed. This allows a new value to be entered for the field just as it would be entered on a PC keyboard or a calculator. If a direction key (←, →, ↑, ↓) is pressed, the cursor changes from a *blinking block* to a *blinking underline*, and single-digit edit mode is entered.

A *blinking underline cursor* appears under an editable field which is being edited in single digit edit mode. In this mode, the digit (or character) above the cursor can be modified individually. This can be done by pressing ↑ or ↓ (increments or decrements) or by pressing a numeric (or alphanumeric) key. Pressing ← or → moves the cursor to the previous or next digit (or character).

CHAPTER 8: SMARTSTACK CONFIGURATION

8.1 General

Chapter Eight provides preliminary configuration procedures that are applicable to all SmartStack Modules. The SmartStack Modules use Cscape Software for configuration.

If not already completed, the user needs to perform the following procedures. After completion, refer to the individual data sheets that contain configuration data that is specific to individual modules

Note: Because the configuration parameters are different for each SmartStack Module, refer to the data sheet that is specific to the selected module. The SmartStack Module Supplement (SUP0246) contains all of the data sheets and is periodically revised.

8.2 Preliminary Configuration Procedures

1. From the Main Menu, select **Controller|I/O Configure**. The following screen appears.

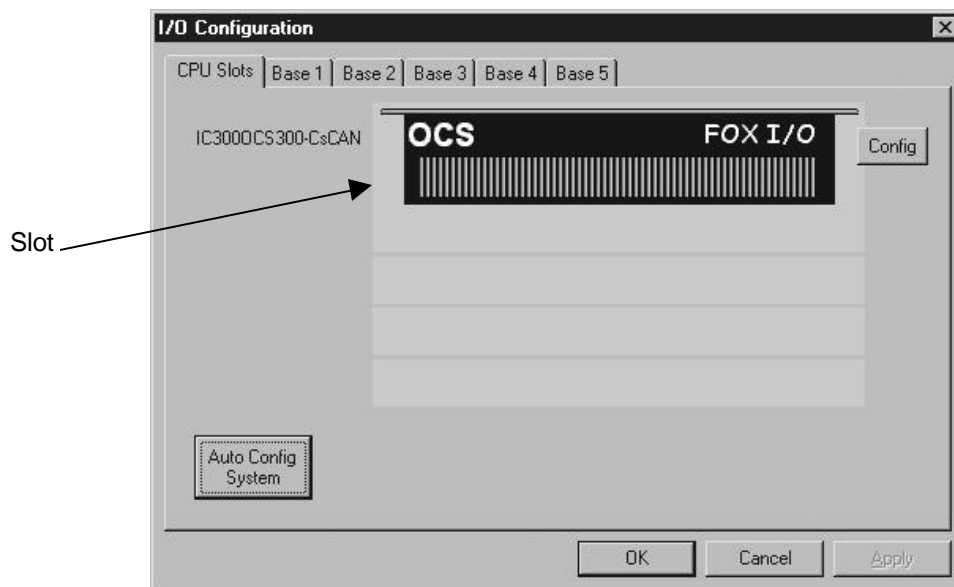

Figure 8.1 - Main Configuration I/O Screen

2. First, ensure that the desired controller is selected. The OCS300-CsCAN is shown as the selected controller (Figure 8.1) in this example. If satisfied with the controller selection, press a **Base #** tab, and go to Step 3. If a different controller) is desired (as it is in this configuration example), continue Step 2.

Note: The **Auto Config System** button can be pressed *prior* to selecting the desired controller *and* I/O. By pressing the button, the settings are deleted from any controller *and* I/O that is physically connected to the PC. A dialog box appears and indicates that settings will be deleted from currently configured models. If OK, press **Yes**. Then press **OK**.

Selecting a Different Controller

To select a different controller, ensure that the **CPU Slots** tab is pressed. Then, click on the slot or the **Config** button. The following screen appears.

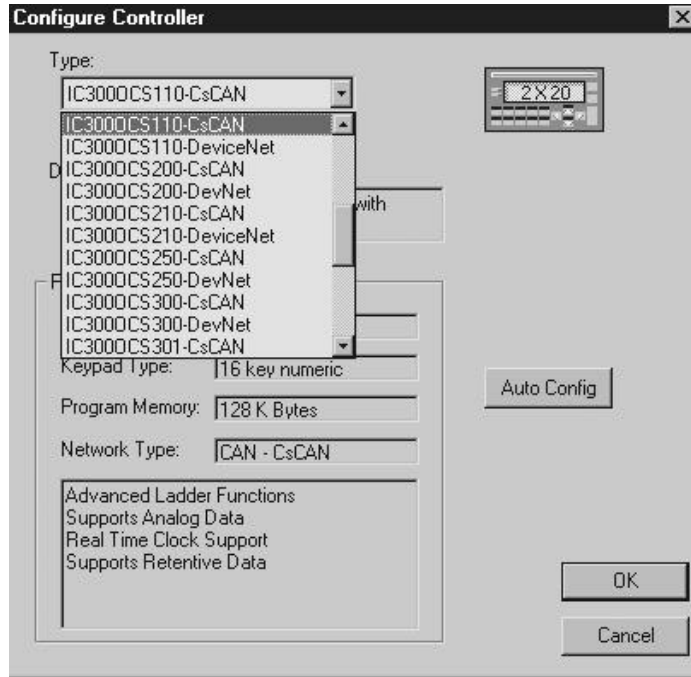

Figure 8.2 – Selecting a Controller

To select a different controller, click on the **Type** list box and select the desired controller. Then press OK. If satisfied with the controller selection, press a **Base #** tab at the top of the screen (Figure 8.1), and go to Step 3.

3. The following screen appears.

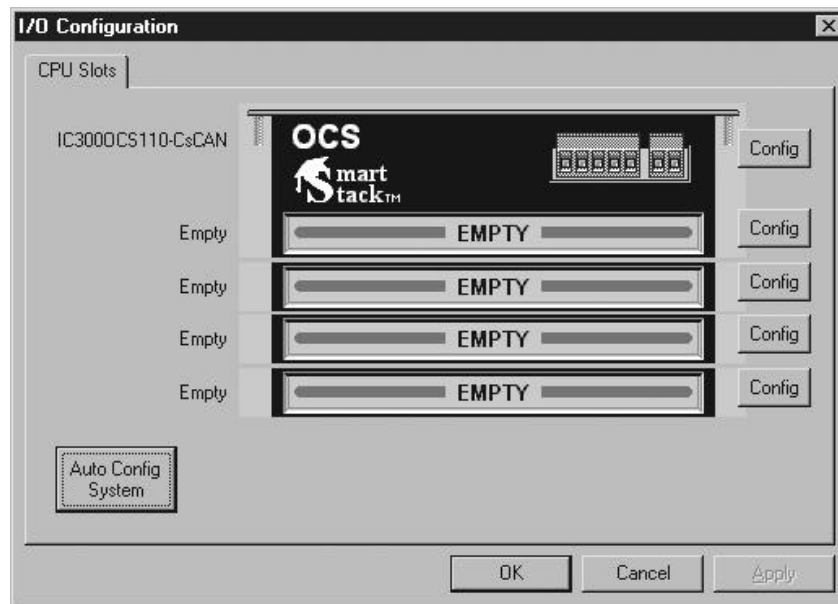

Figure 8.3 – Base 1 Selected

Click on a slot or press the **Config** button located next to the slot. The following screen appears. Select a tab at the top of the screen, and then select an I/O module. (For this example, the DIQ612 has been selected.) Press **OK**.

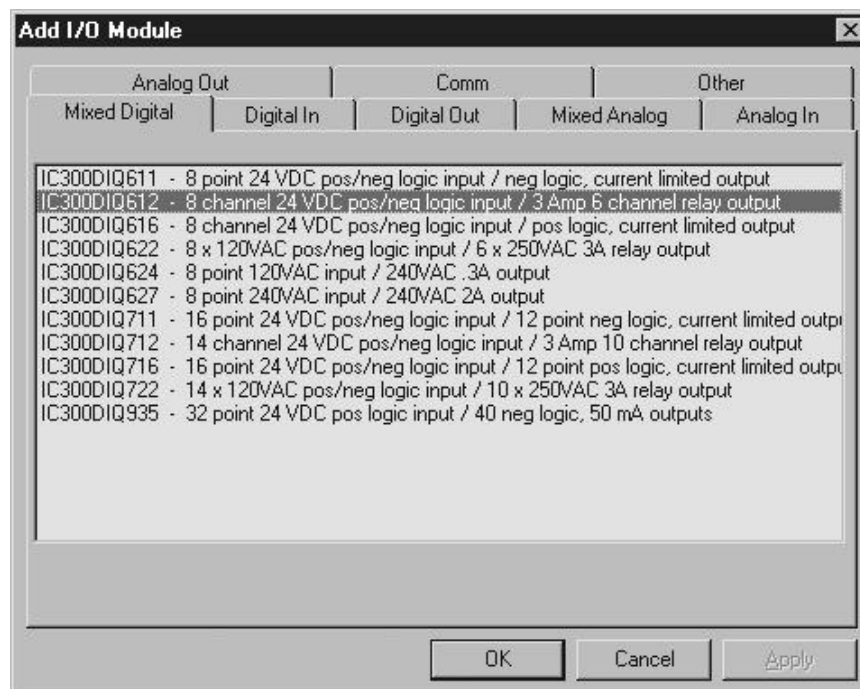

Figure 8.4 – Selecting an I/O Module

4. The following screen appears.

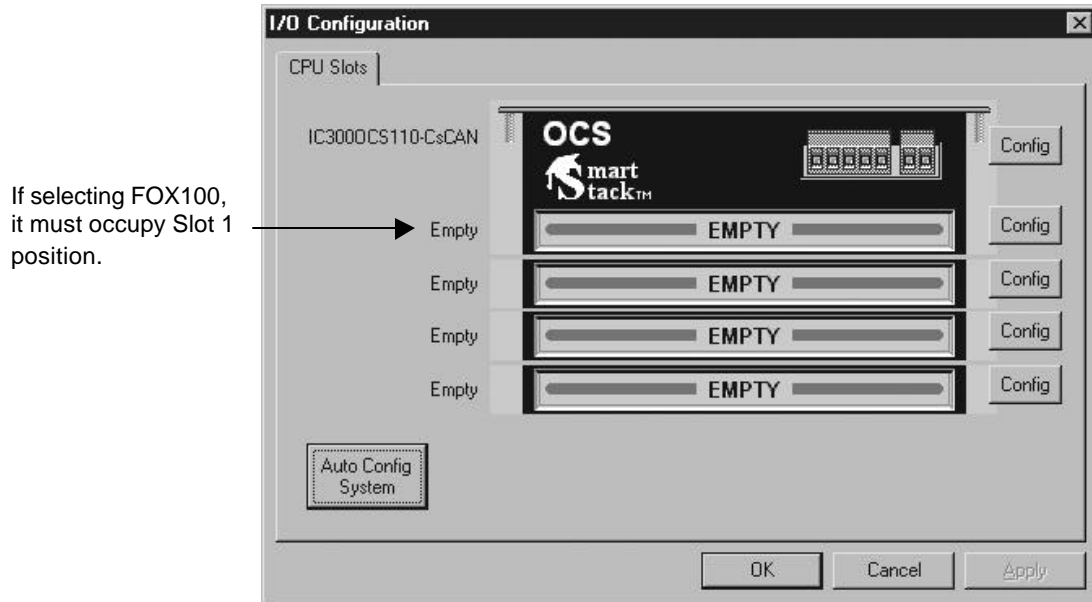

Figure 8.5 – Base 1 with an I/O Module Selected

The description and properties of the I/O module are provided. If satisfied with the selections, press **OK**.

If a module already occupies a slot and a different module is desired, right-click on the slot and press **Replace**. To leave a slot empty, right-click on the slot and press **Delete**. By right-clicking on a slot, its configuration can be **copied** into another slot on the same base or a different base and **pasted** into a new slot.

Selecting SmartStack Fiber Optic Expansion Interface Module (FOX100 / 110)

A FOX100 / 110 module allows an OCS110 / OCS210 / OCS250/ RCS250 to connect up to five Fiber Optic Bases (i.e., FOX404 and FOX104). If a FOX100 / 110 is used, it must occupy Slot 1 on the OCS/RCS as indicated in Figure 8.5. Three remaining slots are available for other types of I/O modules.

After the FOX100 / 110 is added to Slot 1, the following tabs appear at the top of the screen.

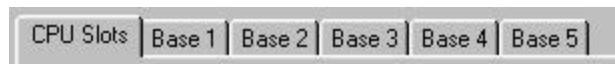

Pressing the **CPU Slots** tab displays the selected controller and the I/O modules attached to it including the FOX100 / 110 in Slot 1.

The **Base#** tabs display the I/O modules connected to each of the five Fiber Optic Bases. Each Fiber Optic Base has four I/O slots, which allow the expansion of up to 20 SmartStack modules to be connected to the OCS/RCS via the FOX100 / 110.

Note: Any Base can be selected for configuration. It is not necessary to select Bases in a specific order.

5. The following screen appears. Two tabs are available for selection:

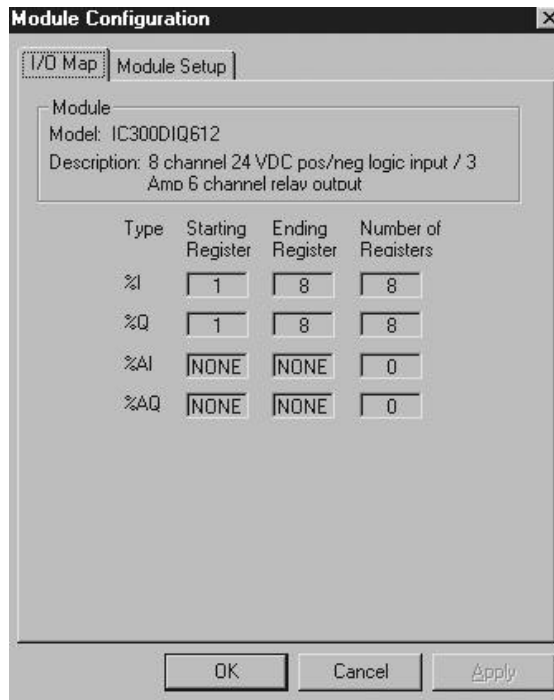

Figure 8.6 – I/O Map Tab Selected

a. I/O Map Tab

The **I/O Map** describes the I/O registers assigned to a specific I/O module. Although there are no user-defined parameters, the I/O Map can be viewed after the SmartStack module is configured to review the registers.

- Model number Provides the part number.
- Description Describes the number of input and output channels and other key characteristics of the module.
- Type: Displays the register types assigned to the module.
- Starting Location: Denotes the starting location of the register type.
- Ending Location: Denotes the ending location of the register type.
- Number: Indicates the quantity of a particular register type.

Note: Do not confuse the described number of input and output channels with the numbers found in the Type column (i.e., %I and %Q). The numbers do not necessarily match.

b. **Module Setup Tab**

Note: The Module Setup screen varies according to the module selected. Users make selections based upon requirements. Guidelines that are specific to the module are provided in individual data sheets. **It is important to consult the datasheet for specific details pertaining to the Module Setup tab.**

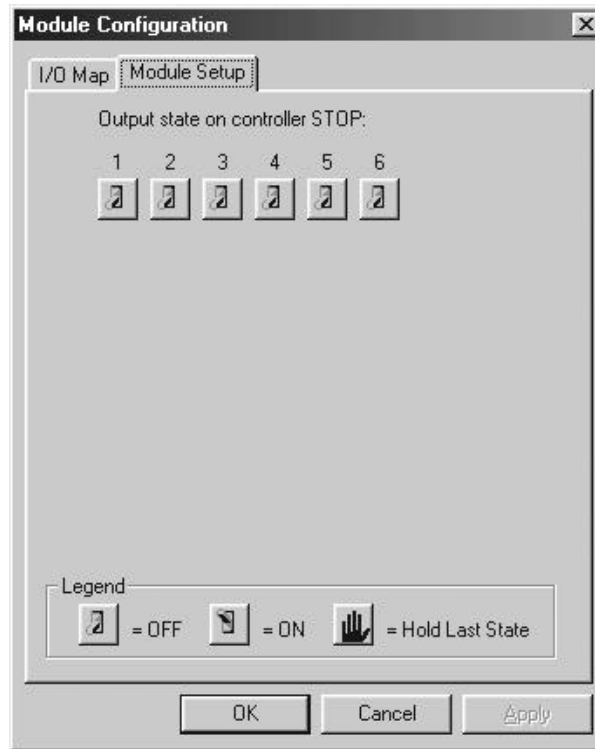

Figure 8.7 – Module Setup Tab Selected

The **Module Setup** is used in applications where it is necessary to change the default states of the outputs when the controller (e.g., OCS1XX) enters idle/stop mode. The default turns the outputs OFF when the controller enters idle/stop mode. By selecting the Module Setup tab, each output can be set to either turn ON, turn OFF or to hold the last state. Generally, most applications use the default settings.

Warning: The default turns the outputs OFF when the controller enters idle/stop mode. To avoid injury of personnel or damages to equipment, exercise extreme caution when changing the default setting using the **Module Setup** tab.

6. Depending upon the I/O module selected, additional configuration procedures can be required. Be sure to consult the individual data sheet to determine if a supplement is available for the specific module. Supplements provide configuration information and cover other important topics pertaining to a specific module.

CHAPTER 9: FIBER OPTIC EXTENSION SYSTEM (FOX104 / FOX404)

9.1 General

Chapter Nine covers the Fiber Optic Extension Base and Hub (FOX104 / FOX404).

The FOX104 / FOX404 extends a high-speed OCS backplane enabling SmartStack I/O Modules to be mounted several meters from the OCS. The FOX104 / FOX404, also, significantly increases the number of SmartStack I/O modules supported by one OCS.

9.2 FOX104 / 404 Specifications

The following specifications and limitations apply when using the FOX104 / FOX404.

Table 9.1 – Hub and Base Specifications(FOX104 / FOX404)	
Maximum number of stacks (total number of hubs and bases)	5
Maximum number of cable drops to any specific hub or base	3
Maximum length of Fiber Optic cable	10 Meters per Drop
Base ID#	Each Base or Hub must have a unique Base ID #.
Expansion I/O	EIAJ RC-5720 Plastic Fiber, TX+RX 10m per drop max host (OCS or hub) to base
Type of Fiber Optic Cable	EIAJ RC-5720 (RC)
Primary Power	9-30VDC @ 400mA maximum
Power Draw	9-30VDC @ 400mA maximum
Height	4.25" (108 mm)
Width	6.63" (168.3 mm)
Mounting Depth	4.7" (119.4 mm)
Operating Temperature	32 - 122°F (0 - 50°C)
Humidity	5% to 95% non-condensing
UL	Class I, Groups A, B, C, D, Division 2
CE	Yes

9.3 Installation

9.3.1 Mounting Orientation

The base of the FOX104 / FOX404 need to be mounted with the proper orientation. Proper orientation helps to ensure a good connection when SmartStack Modules are installed. Up to four SmartStack Modules can be installed per FOX104 / FOX404. The FOX104 / FOX404 is installed inside a panel box.

Caution: Do not stack more than four SmartStack Modules per FOX or RCS or OCS. Improper operation or damage to the FOX / RCS / OCS and SmartStack Modules could result.

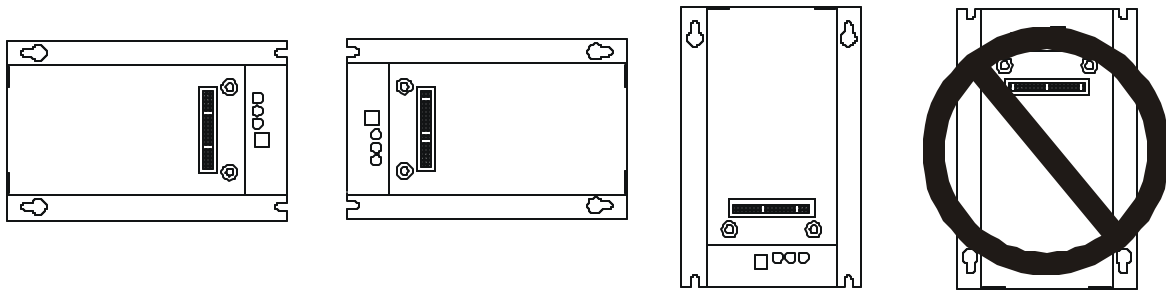

Figure 9.1 – FOX104 / FOX404 Orientation

001FOX006

9.3.2 Mounting Instructions

The FOX104 / FOX404 is designed for permanent panel mounting. To install the FOX104 / FOX404 in a permanent panel mounting, use the instructions that follow:

1. Read Chapter Two prior to mounting the FOX104 / FOX404. Observe requirements for the panel layout design and adequate clearances. A checklist is provided for the user's convenience in Section 2.2.1.
2. Drill holes. (Refer to Figure 9.2.)

Warning: Make sure the power and network connectors are removed from the FOX.

3. Install and tighten washers and nuts. Do not over-tighten.
4. Connect the communications and power cables to the FOX104 / FOX404 ports using the provided connectors.
5. Install up to four SmartStack Modules on the FOX104 / FOX404.

9.3.2 Dimensions and Hole Pattern

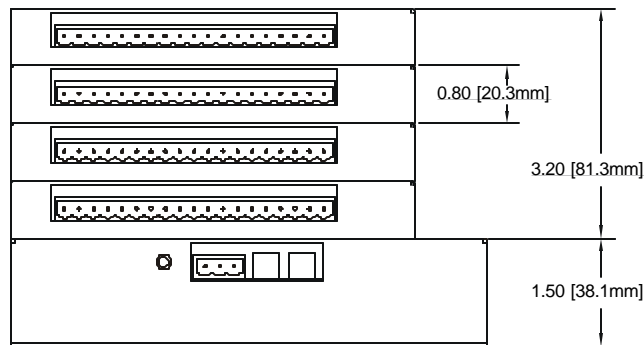
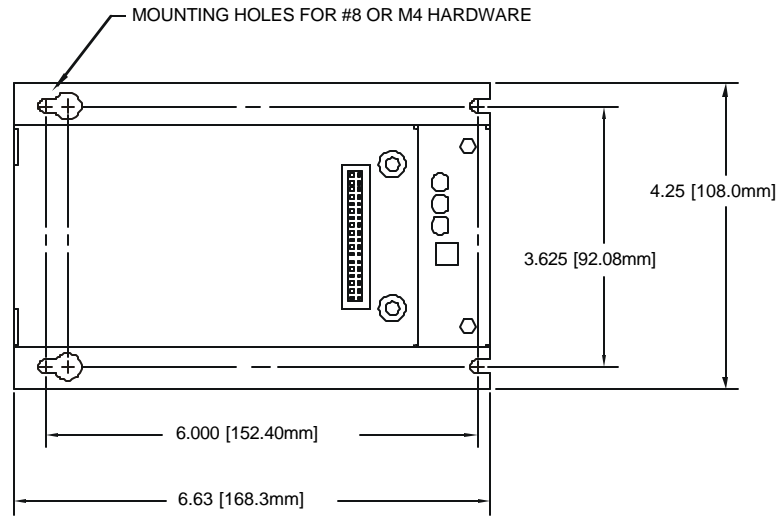

001FOX001

NOTE: Use #8-32 or M4 mounting hardware consisting of four pan head screws with external tooth lock washers.

Figure 9.2 – FOX104 / FOX404 Hole Pattern Dimensions (Top) and FOX104 / FOX404 viewed with 4 SmartStack I/O Modules (Bottom)

9.4 Ports, Connectors, and Wiring

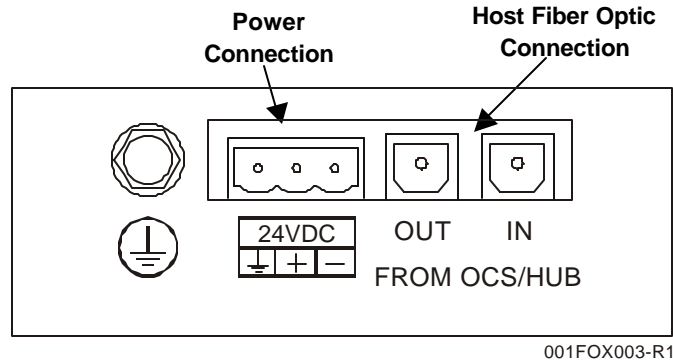

Figure 9.3 – FOX104 / FOX404 Connectors

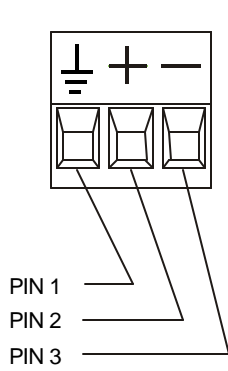

Figure 9.4 - FOX Power Connector

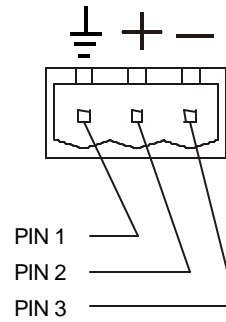

Figure 9.5 - FOX Power Connector

Note: Power Supply Voltage Range is from 10-30 VDC.

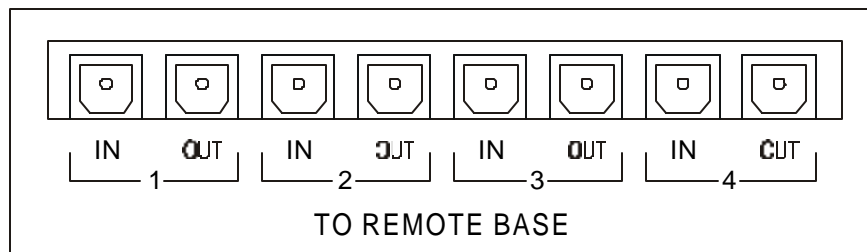

Figure 9.6 – FOX404

Table 9.2 – Fiber Optic Cables		
Feet (Meters)	Part Number	
3.3 ft. (1 m)	HE800CBF001	
6.6 ft. (2 m)	HE800CBF002	
16.4 ft. (5 m)	HE800CBF005	
32.8 ft. (10 m)	HE800CBF010	
In the event of an emergency, the following <i>Radio Shack</i> cables can also be used:		
Feet (Meters)	Part Number	Price (Note: Subject to change without notice. Check with Radio Shack for current prices.)
3 ft. (0.9 m)	15-1580	\$24.99
6 ft. (1.8 m)	15-1581	\$34.99
12 ft. (3.7 m)	15-1582	\$44.99

9.5 Base ID Switches

Each FOX104 / FOX404 needs a unique Base ID. (Refer to Figure 9.7 for location of Base ID Switches.) Set Base ID switches using the following table.

Table 9.3 - Base ID Switches			
ON = 1 OFF = 0			
Base ID	Switch Number		
	2	1	0
Illegal	0	0	0
1	0	0	1
2	0	1	0
3	0	1	1
4	1	0	0
5	1	0	1
6	1	1	0
7	1	1	1

9.6 FOX104 / FOX404 LEDs

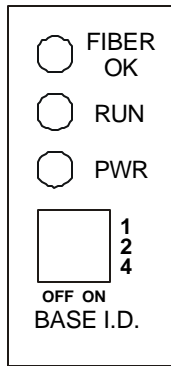

001FOX005

Table 9.4 – FOX104 / FOX404 LEDs	
FIBER OK	ON indicates FOX's fiber input cable is properly connected and is receiving a carrier.
PWR	ON indicates FOX is receiving power.
RUN	<ul style="list-style-type: none"> • OFF indicates OCS is in IDLE/STOP mode or no power to the FOX or one of the fiber cables are detached or there is a configuration mismatch. • Flashing indicates DO / IO mode or RUN with no ladder program. • ON indicates ladder code running.

Figure 9.7 – FOX104 / FOX404 LEDs

9.7 Example Setups

Note: The following examples depict the FOX100, but they also apply to the FOX110.

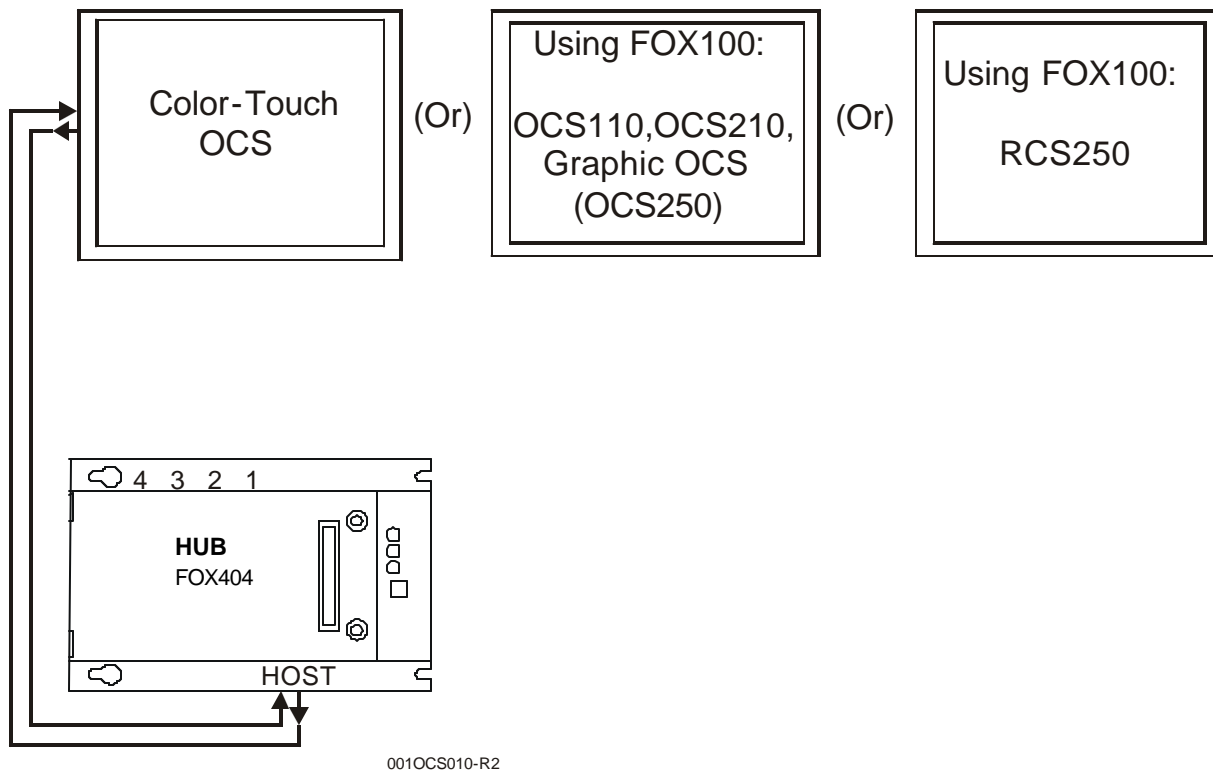

001OCS010-R2

Figure 9.8 – OCS/RCS to FOX404 (Single Hub) via FOX100

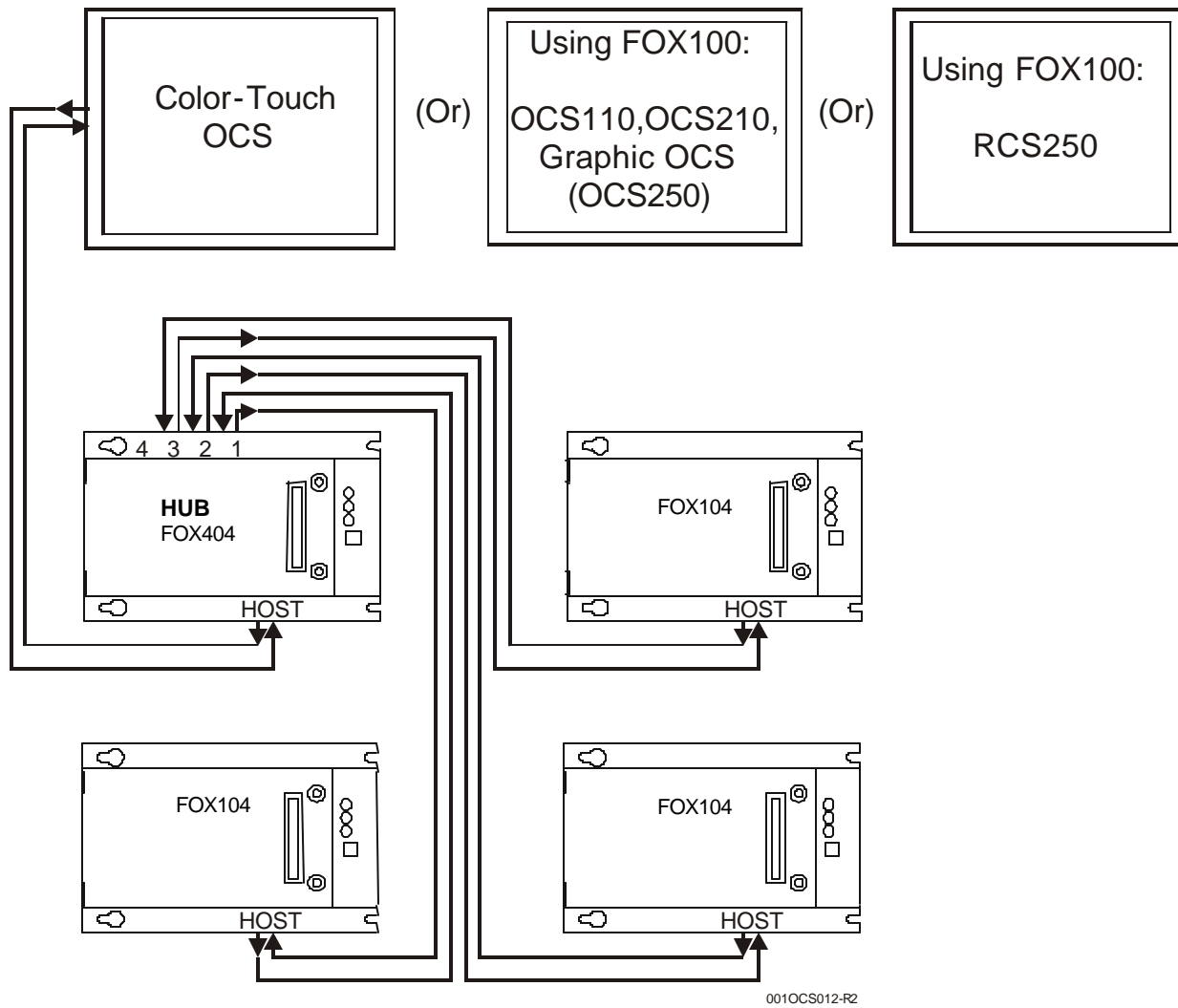

Figure 9.9 – OCS/RCS to FOX (One Hub [FOX404] and Multiple Bases [FOX104]) via FOX100

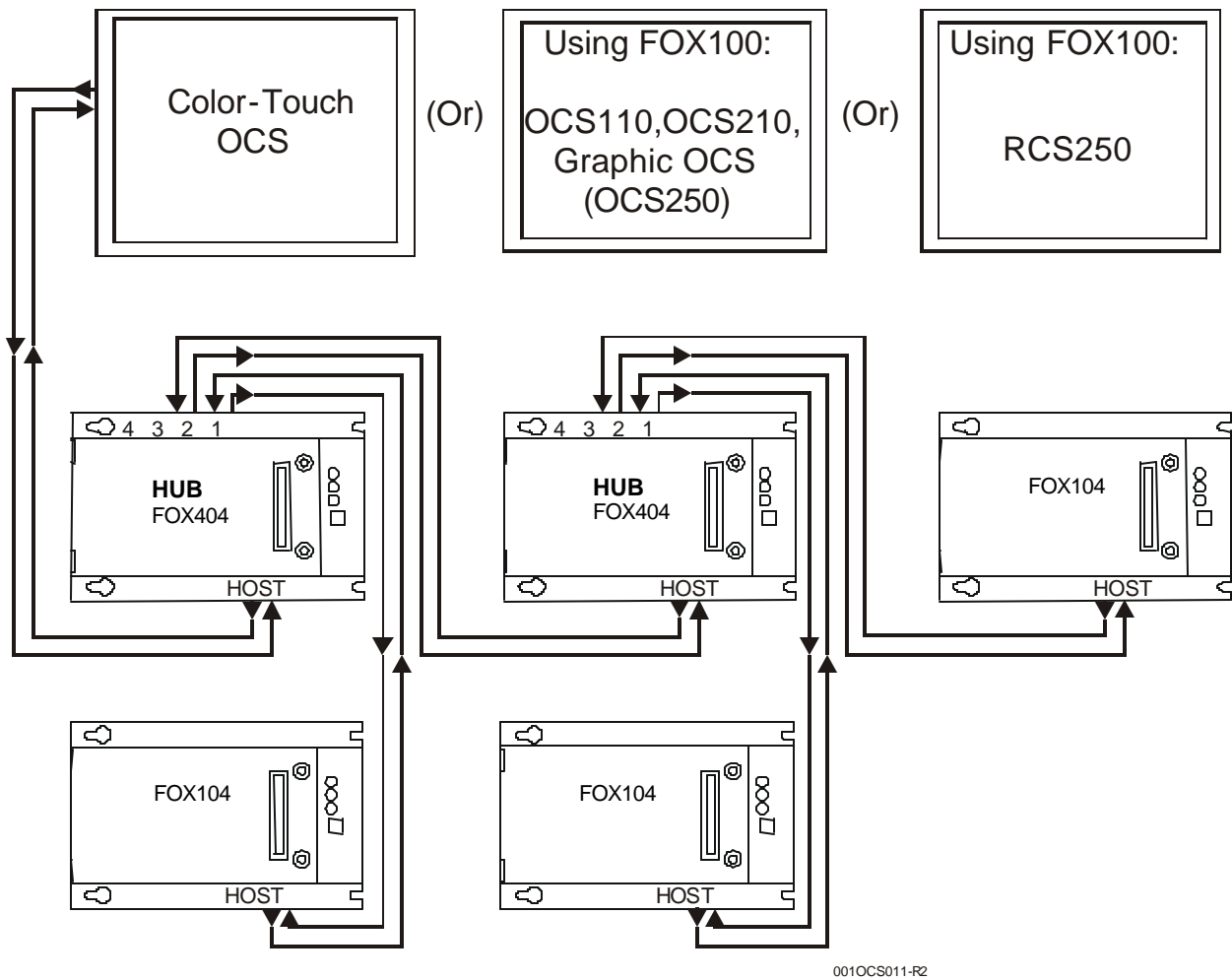

Figure 9.10 – OCS/RCS to FOX (Multiple Hubs [FOX404] and Bases [FOX104])
via FOX100

CHAPTER 10: SMARTSTACK FIBER OPTIC EXPANSION MODULE (FOX100 / 110) AND FIBER MEDIA CONVERTER (SFX100)

10.1 General

Chapter Ten covers the Fiber Optic Expansion Module (FOX100 /110).

The FOX100 / 110 allows an OCS/RCS to connect up to five Fiber Optic Expansion bases and hubs (i.e., FOX104 and FOX404). For more information about Fiber Optic Expansion Systems, refer to Chapter 9.

Note: The FOX100 and FOX110 are designed for use only with the following OCS/ RCS controllers: OCS110 / OCS210 / Graphic OCS250, and RCS250.

When the FOX100 / 110 is used with a FOX104 or FOX404, they extend a high-speed OCS/RCS backplane enabling SmartStack I/O Modules to be mounted several meters from the OCS/RCS. They also significantly increase the number of SmartStack I/O modules supported by one OCS/RCS.

In addition, there are two methods available to extend the fiber optic link by an additional 1500m using the **Fiber Media Converter (SFX100)**: (The SFX100 is covered in this chapter.)

- a. Use a **FOX100** and **Two** SFX100s.
- b. Use a **FOX110** and **One** SFX100.

The **FOX100** and **FOX110** are basically identical except that the FOX110 contains two glass fiber transducers, which can be used to connect a glass fiber cable directly to an SFX module. This requires the use of only one SFX module instead of two SFXs.

10.2 FOX Specifications and Limitations

Maximum number of stacks (total number of hubs and bases)	5
Maximum number of cable drops to any specific hub or base	3
Maximum length of Fiber Optic cable	10 Meters per Drop If SFX stuffing option is used: Extends 1500m
Base ID#	Each Base or Hub must have a unique Base ID #.
Expansion I/O	EIAJ RC-5720 Plastic Fiber, TX+RX 10m per drop max host (OCS or hub) to base
Type of Fiber Optic Cable	EIAJ RC-5720 (RC)
Primary Power	9-30VDC @ 400mA maximum
Power Draw	9-30VDC @ 400mA maximum
Height	4.25" (108 mm)
Width	6.63" (168.3 mm)
Mounting Depth	4.7" (119.4 mm)
Operating Temperature	32 - 122°F (0 - 50°C)
Humidity	5% to 95% non-condensing

10.3 Connectors and Slot Positions

The FOX100 / 110 must be placed in the first slot of the controller. For **Ethernet** capability, the SmartStack Ethernet Module (ETN1xx) is plugged into the FOX100 / 110. (In this case, the ETN needs to occupy the second slot of the controller.)

Note: The FOX100 / 110 has a 10-pin connector, which is reserved for factory use only.



001FOX007

Figure 10.1 – FOX100 / FOX110 Connectors

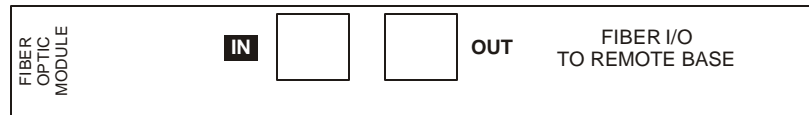

001FOX010

Figure 10.2 – FOX100 / FOX110 Connectors

10.4 LEDs

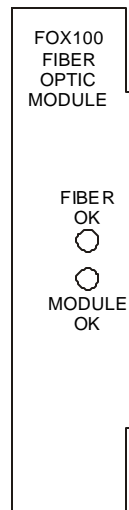

001FOX009

Figure 10.3 – FOX 100 LEDs

Table 10.1 – LEDs (FOX100 / 110)	
LED	Meaning
Module OK	ON if firmware is loaded and operating properly.
Fiber OK	ON indicates a Fiber carrier is being received from first base/hub.

10.5 Example Setups

The following graphics depict the use of a FOX100 in a variety of setups.

The FOX100 / 110 allows an OCS/RCS to connect up to five Fiber Optic Expansion bases and hubs (i.e., FOX104 and FOX404). When the FOX100 / 110 is used with a FOX104 or FOX404, they extend a high-speed OCS/RCS backplane enabling SmartStack I/O Modules to be mounted several meters from the OCS/RCS. They also significantly increase the number of SmartStack I/O modules supported by one OCS/RCS.

Note: The following examples depict the FOX100, but they also apply to the FOX110.

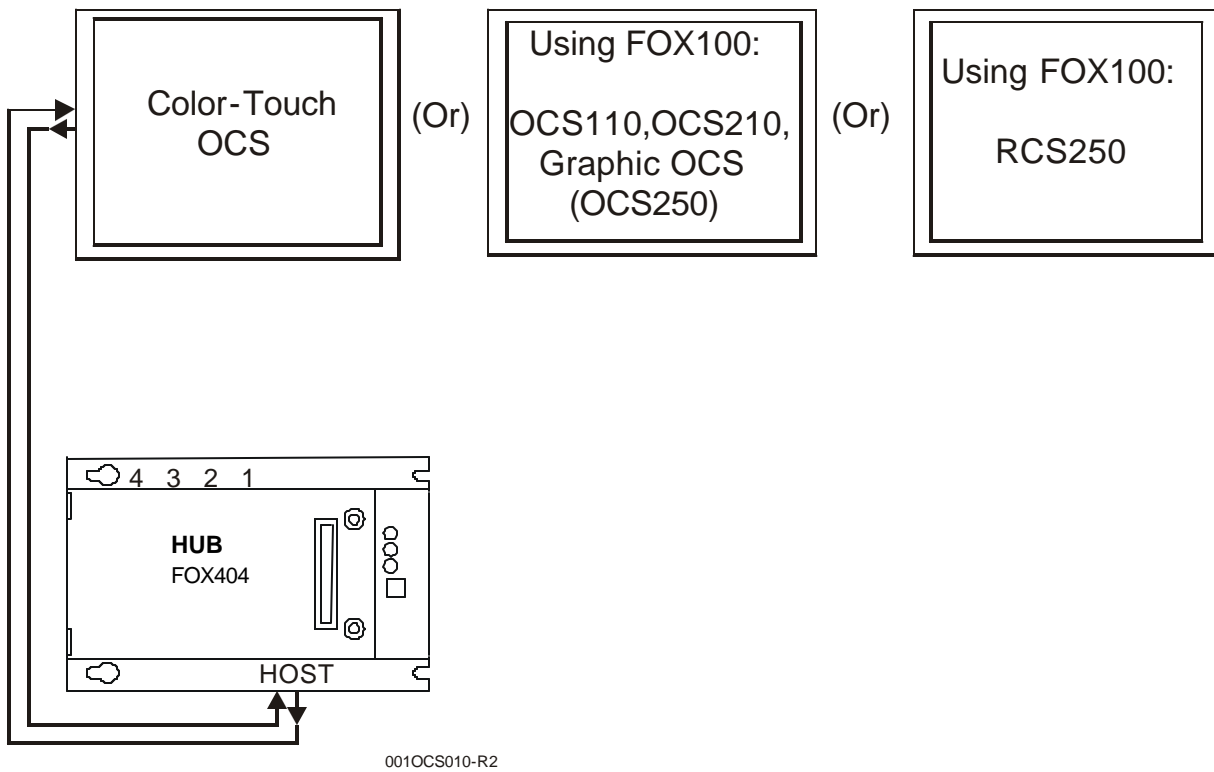

Figure 10.4 – OCS/RCS to FOX404 (Single Hub) via FOX100 / FOX110

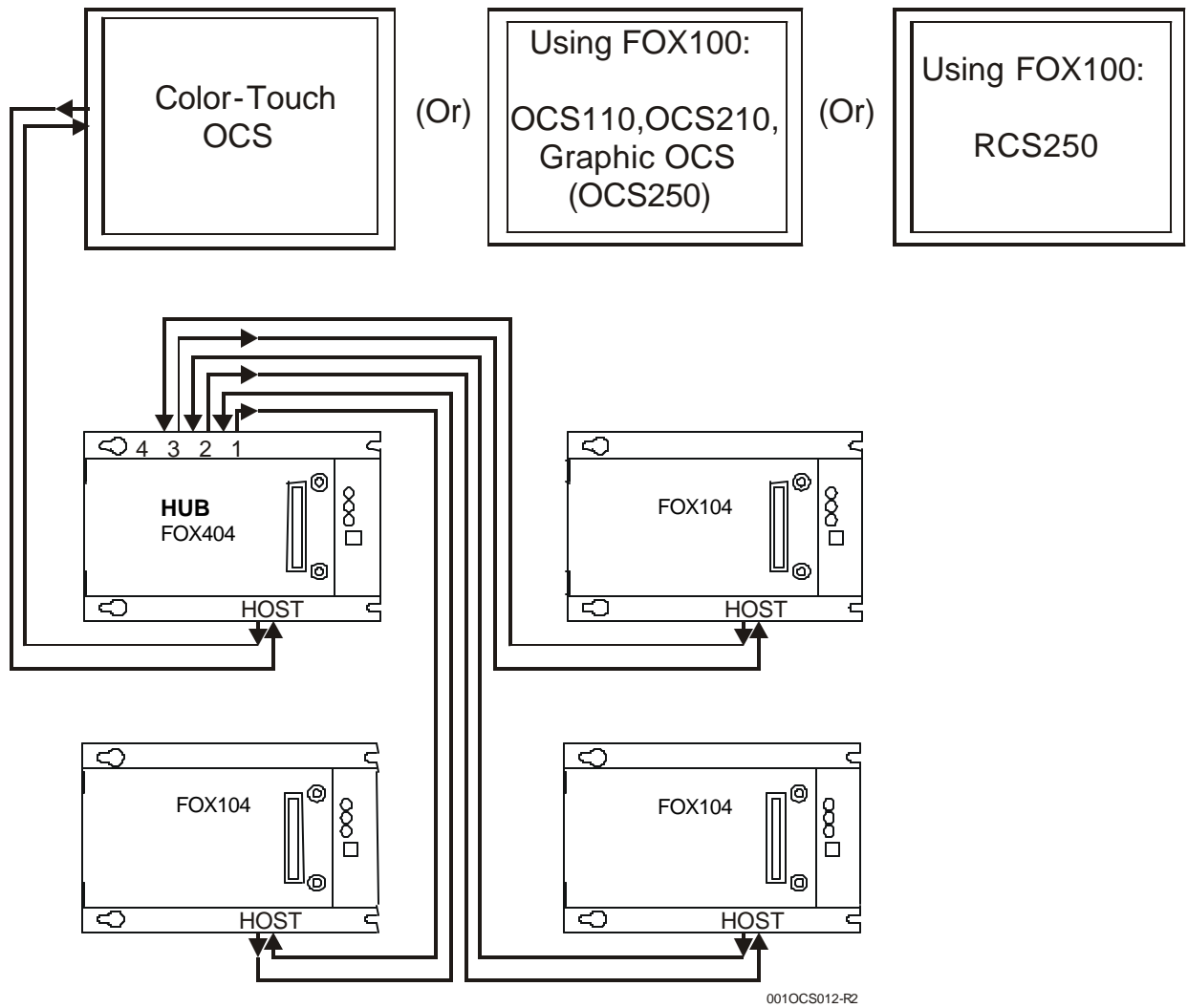

Figure 10.5 – OCS/RCS to FOX (One Hub [FOX404] and Multiple Bases [FOX104]) via FOX100

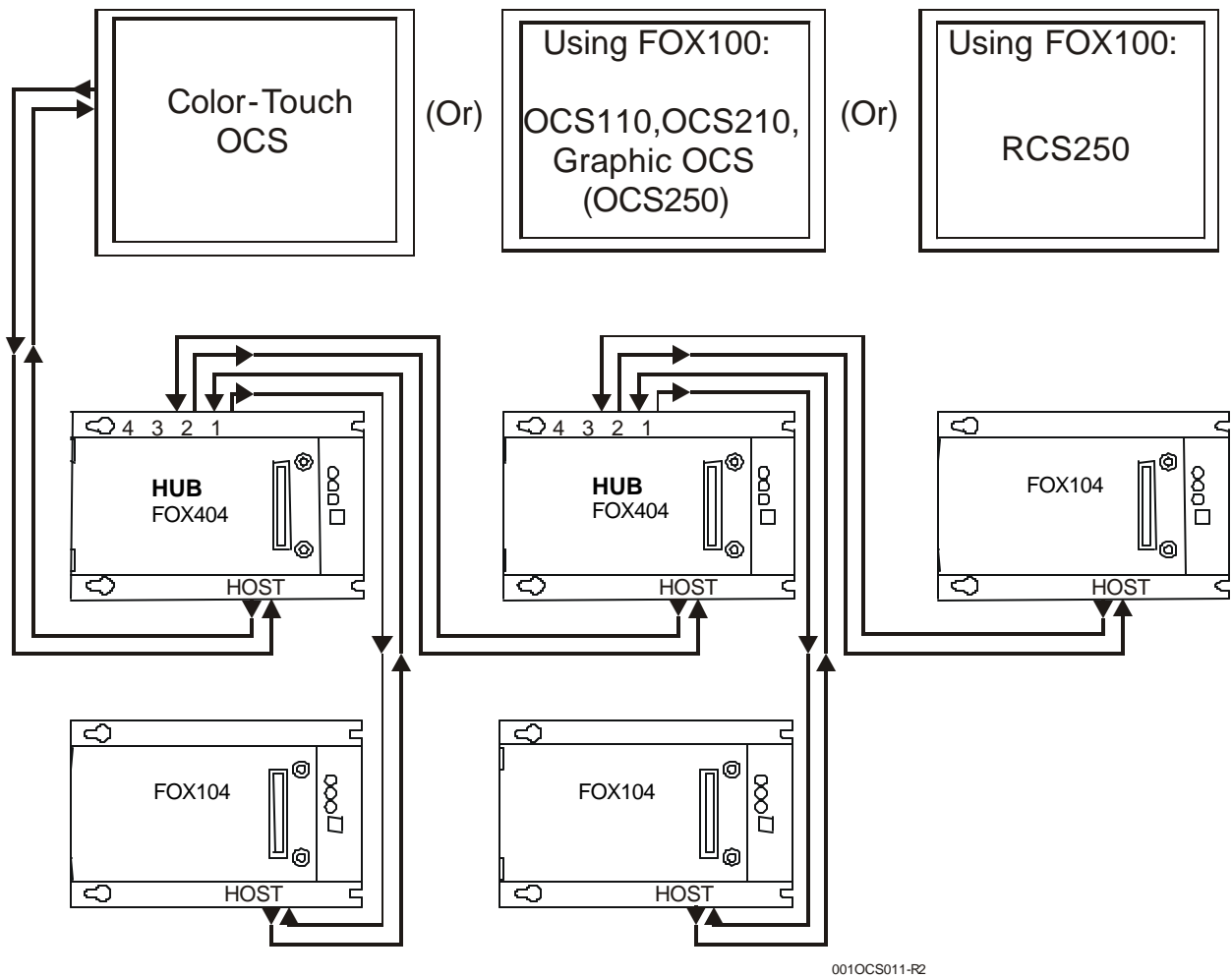
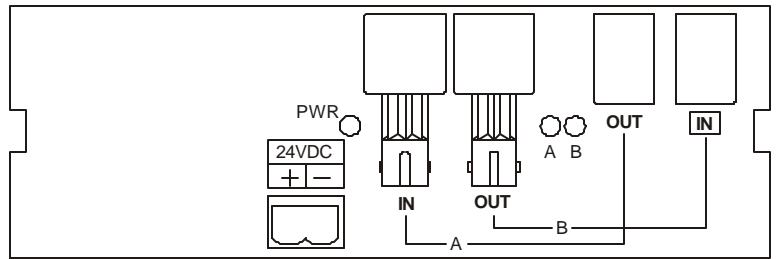

Figure 10.6 – OCS/RCS to FOX (Multiple Hubs [FOX404] and Bases [FOX104]) via FOX100

10.6 Fiber Media Converter (IC300SFX100)



001SFX001

Figure 10.7 –SFX100 Expansion Module

The **Fiber Media Converter (SFX100)** is a plastic-to-glass converter, which can be used to extend the fiber optic link up to 1500m. Depending whether the FOX100 or FOX110 is used with an OCS110 / 210 / 250 or RCS250, one or two SFX units are required to accomplish the extension of the link.

Note: The SFX Module can not be used with the OCS100 / OCS200.

10.6.1 Using FOX100 with SFX

When a **FOX100** is installed in an OCS110 / 210 / 250 or RCS250, **two** SFX100s are required to extend the fiber link.

A close-up of the wiring between two SFX modules is shown in Figure 10.8.

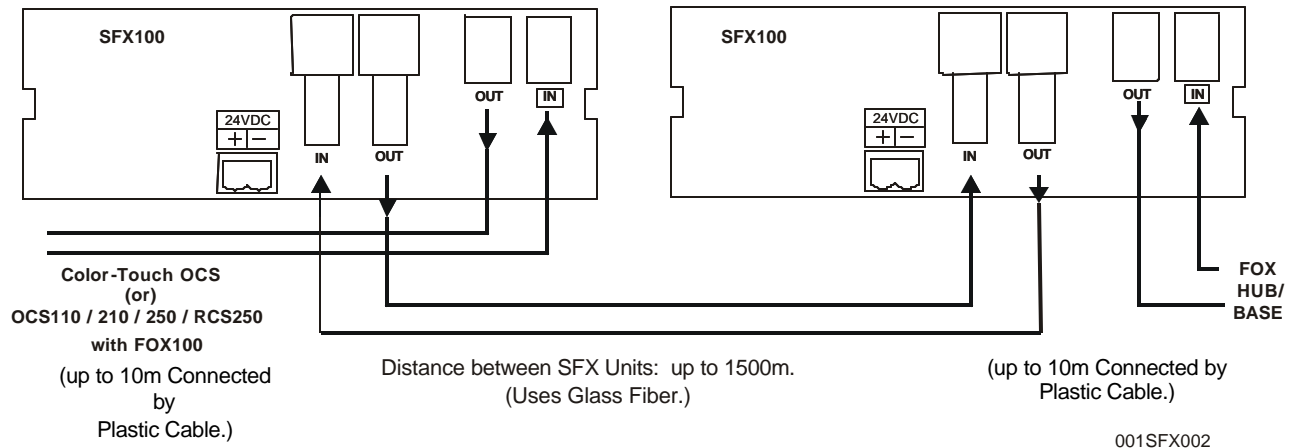

001SFX002

Figure 10.8 – Close-up of SFX Wiring

Figure 10.9 depicts a wiring example using a FOX100 and two SFX units.

The SFX100 (left) is connected via a plastic 10m cable to either:

- a. A Color-Touch OCS or
- b. An OCS110 / 210 / 250 / RCS250 using a **FOX100**.

A glass cable is then used to connect the two SFX devices to extend the link up to 1500m. Finally, the SFX100 (right) is connected to the FOX Hub / Base with a plastic cable (10m).

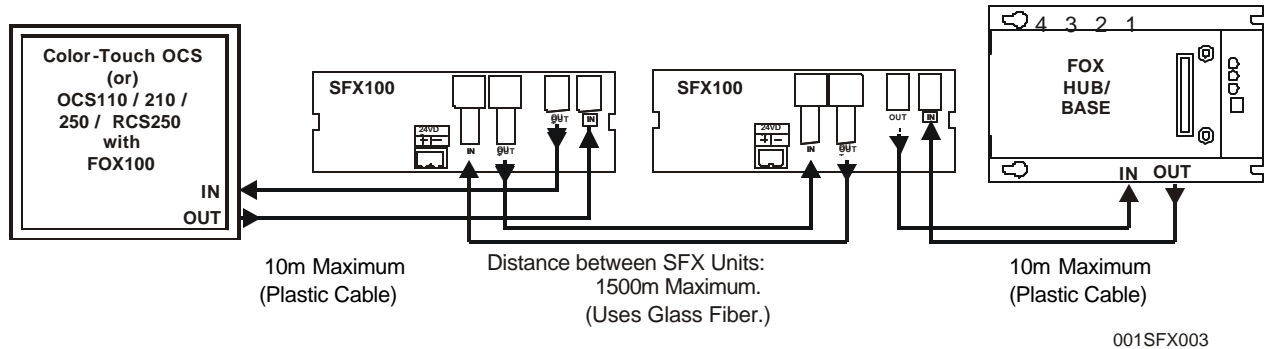

Figure 10.9 – Two SFX Modules and a FOX100

10.6.2 Using FOX110 with SFX

When a **FOX110** is used with an OCS110 / 210 / 250 or RCS250, only **one** SFX100 is required. The FOX110 allows a glass fiber cable to be directly connected to an SFX module and to extend the link up to 1500m. This capability eliminates the need for a second SFX100.

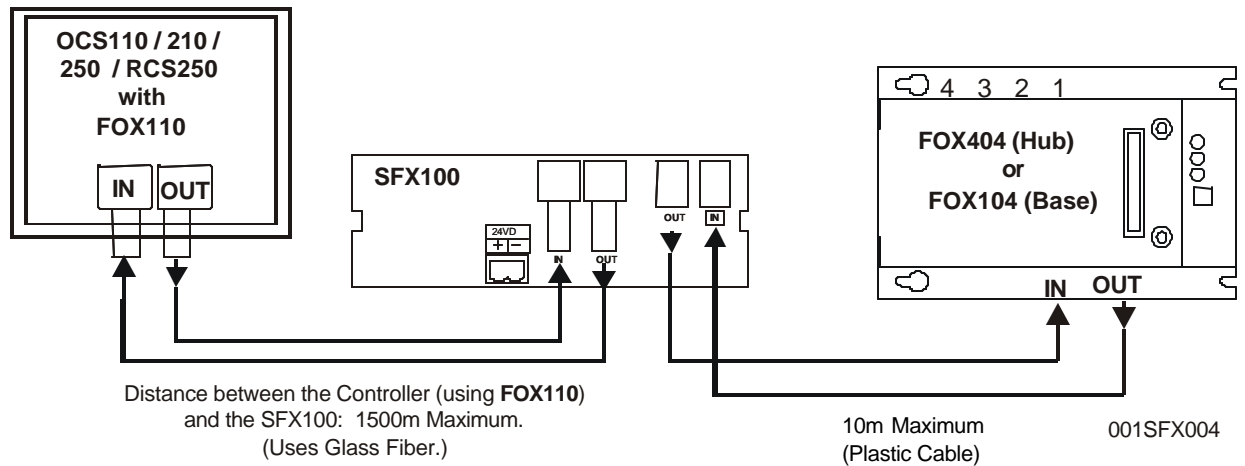

Figure 10.10 – One SFX Module and a FOX110

Figure 10.10 depicts an SFX wiring example using the FOX110.

One SFX100 is connected via a glass fiber cable to either an OCS110 / 210 / 250 or RCS250 (using a **FOX110**) to extend the link up to 1500m. Finally, the SFX100 is connected to the FOX Hub / Base with a plastic cable (up to 10m).

NOTES

APPENDIX A: NETWORKS

1 CAN and CsCAN Networks

Appendix A describes the Controller Area Network (CAN) and CsCAN/DeviceNet.

2 Controller Area Network (CAN) Overview

The controller area network (or CAN bus) is a serial communications bus that was originally developed in the late 1980's by a German company (Robert Bosch) for use in the automotive industry. CAN is an ISO (International Standards Organization) - defined serial communications bus for real-time applications. Established in 1947, the International Standards Organization (ISO) is a multinational body dedicated to worldwide agreement on international standards. Specifically, CAN is documented in ISO 11898 (for high-speed applications) and ISO 11519 (for lower-speed applications).

a. CAN Features

CAN-based open automation technology successfully competes on the market of distributed automation systems because of the special features of the CAN protocol. The special features are CAN's producer-consumer-oriented (or peer-to-peer) principle of data transmission and its multi-master capability. The general design of CAN originally specified a high bit rate, high immunity to electrical interference and an ability to detect any errors produced. CAN networks have the following general attributes:

- Automatic error detection
- Easily configurable
- Cost-effective to design and implement
- Capable of operating in harsh environments

b. CAN Protocol

The CAN communications protocol simply describes the method by which information is passed between various devices. The CAN protocol conforms to the Open Systems Interconnection (OSI) model. An open system is a set of protocols that allows any two different systems to communicate regardless of their underlying architecture. The OSI model is defined in terms of seven ordered layers. These layers consist of the Physical (bottom-most layer), Data Link, Network, Transport, Session, Presentation and Application (top-most layer). CAN architecture defines the bottom two layers of the model. These layers are the physical and data link layers.

The physical and data link layers are typically transparent to the system designer and are included in any component that implements the CAN protocols. The physical layer is responsible for functions such as physical signaling, encoding, bit timing and bit synchronization. The data link layer performs functions such as bus arbitration, message framing and data security, message validation, and error detection. The application levels are linked to the physical medium by the layers of various emerging protocols (such as DeviceNet™), dedicated to particular industry areas plus a variety of custom protocols defined and developed by individual CAN users.

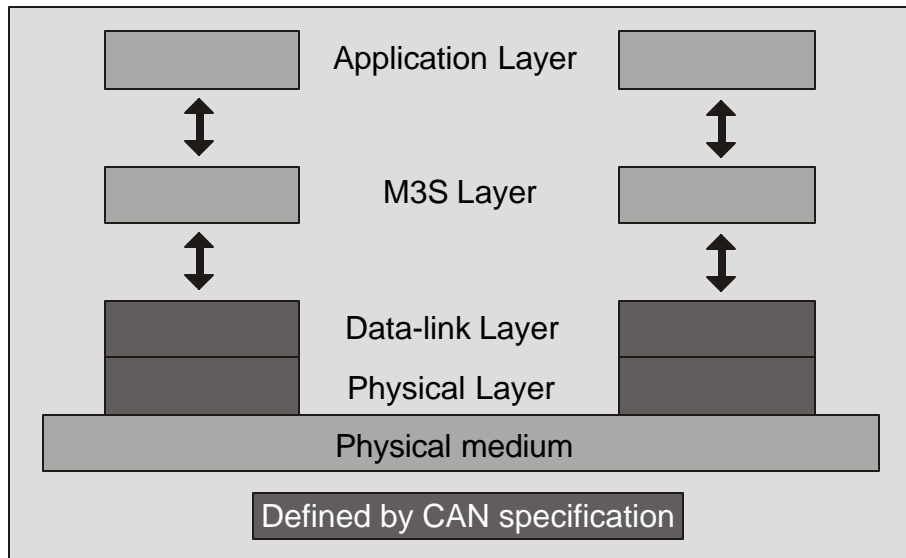

Figure 1 - OSI-Based Model

c. CAN Operation

CAN is capable of using a variety of physical media for transmission purposes. Two examples are twisted wire-pairs and fiber-optics. The most common physical medium consists of a twisted-pair with a termination resistance that is applicable to the cable in use (the CsCAN network typically calls for the use of a 121Ω resistor). CAN operates at data rates of up to 1 Megabits per second.

The signaling in CAN is carried out using differential voltages. The two signal lines are termed 'CAN_H' and 'CAN_L'. The use of voltage differentials allows CAN networks to function in very noisy environments. With the twisted pair, differential configuration, each wire is closer to the noise source (if a noise source is present) for half the time and farther away for the other half. Therefore, the cumulative effect of the interference is equal on both wires, thus canceling the interference.

The Full CAN protocol allows for two lengths of identifiers. These two parts are "Part A" and "Part B". Part A allows for 11 message identification bits, which result in 2032 different identifiers. Extended CAN (Part B) utilizes 29 identification bits, resulting in 536,870,912 separate identifiers.

Note: DeviceNet™ currently specifies Part A only, and the balance of this discussion is specific to Part A only.

Part A devices are *only* able to transmit and receive *standard* CAN protocol. If Part A devices are used on an *extended* CAN system in which 29 bit IDs are present, the device causes errors and the entire network may not operate correctly. The Philips SJA1000 is a Part A device (11 ID bits) but has the ability to be used with extended CAN without causing any bus errors. This is achieved by ignoring the extended CAN frames, which are known as "part B passive" devices and are similar to what Horner uses. The data link layer defines the format and timing protocol with which the messages are transmitted. There are two descriptor bytes and up to eight data bytes. The descriptor bytes are important, because they define the priority of the message and the type of message being transmitted.

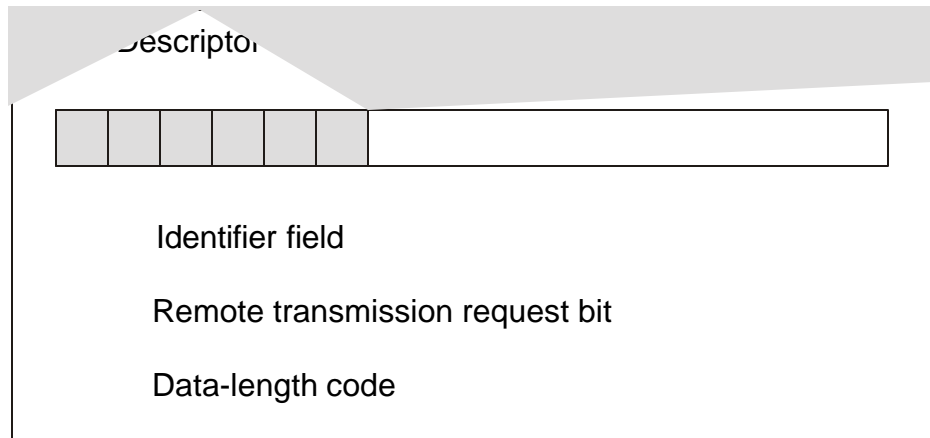

Figure 2 – Descriptor Bytes

There are 11 bits in the identifier field. The bits are used for identification of the message as well as determining its bus access priority. The priority is defined to be highest for the smallest binary value of the identifier. One very attractive quality of CAN is that it is capable of allocating priorities to messages. This feature makes it attractive for use within real-time control environments. All bits of the identifier field define the message priority. The CAN specification guarantees the latency time associated with priority values.

Since the CAN protocol specifies no rules for the assignment of message-identifiers, a variety of different, application-specific uses are possible. Assignment of the CAN message identifiers therefore is one of the most important decisions when designing a CAN-based communication system.

To summarize, CAN is currently being used in a very large number of applications in the automotive industry and in many other industrial applications. CAN is an excellent network to use in situations where microcontrollers need to communicate with each other or with remote devices. The popularity of CAN has been the result of the automatic error detection capabilities, the ability to operate in harsh environments, the relatively low-cost for development tools, and the wide availability of hardware.

3 CsCAN Network Overview

The CsCAN Network was first developed in 1993 by Horner Electric. It was developed for use in a project that Horner Electric completed for the United States Post Office. Horner Electric developed its own network, because it needed a network that had a specific set of powerful peer-to-peer and host-to-node capabilities. The CsCAN Network has a “pass-through” feature whereby PC-based programs access other nodes connected to a network by passing the programming command through the serial port to the network port. (For a more detailed description, see below.) Horner Electric found that by developing its own network, it satisfied several important needs. Horner Electric continues CsCAN Network development to satisfy the requirements of today and the requirements of the future.

CsCAN Network Features

The CsCAN Network is based on CAN, which has many desirable features such as ruggedness, ease of configuration, etc. With Horner Electric Controllers, data is passed at 125Kbps using a differential pair of wires plus a ground. It is important to note that the data rate is not limited to 125Kbps. The maximum data rate is 1Mbps (limited by the speed of light). The CAN implementation in the CsCAN controller allows up to 64 controllers to be networked with no additional hardware and up to 253 controllers with three CAN repeaters.

For the ladder programmer, little knowledge of networking procedures is needed. However for troubleshooting and optimizing, the following information is helpful. Instead of using master/slave or token passing, the hardware self-arbitrates based on the Network ID. **Controllers with lower Network ID numbers are given a higher priority than controllers with higher Network ID numbers.**

CsCAN Network Operation

When a controller needs to send data over the network, it first waits for the network to be idle (currently a maximum of 900 μ s). If two controllers start broadcasting information on the network at the same time, the "self-arbitration" causes the controller with the greater Network ID number to cease broadcasting without affecting the message-in-progress of the other controller.

In applications with a large number of networked controllers, better results may be achieved by assigning lower Network IDs to controllers that have more critical network data than other controllers. By assigning higher Network IDs to controllers that provide numerous network updates, the controllers are prevented from monopolizing the bus time.

Each controller is capable of broadcasting Global Digital Output bits (%QG) and Global Analog Output bits (%AQG), which are periodically broadcasted to the other controllers on the network. The coil representations %QG and %AQG may be used in ladder logic like any other coil or register reference.

All global outputs are broadcast to the network according to the way the programmer sets them up under Program, Network Config in Cscape.

In addition to global data, the CsCAN Network is used to exchange data between a controller on the network and a PC-based Host Supervisory Tool such as the Cscape Ladder Editor or an OEM-specific cell controller.

A useful feature of the CsCAN network is that it supports a "Host-to-Node" protocol and has the ability to "pass through" programming commands. A programming package (like Cscape™), when attached to a Control Station serial port, can access other Control Station units connected to a network by passing the programming command through the serial port to the network port. In this way, one Cscape™ package connected to one Control Station unit can program all Control Station units on the network.

4 DeviceNet Overview

DeviceNet is an open network. The specification and the protocol are open. Vendors are not required to purchase hardware, software or licensing rights to connect devices to a system.

a. DeviceNet Features

DeviceNet is a low-cost communications link to connect industrial devices. It allows the interchangeability of simple devices while making interconnectivity of more complex devices possible. DeviceNet is based on CAN. It is an application layer protocol (ISO layer 7) and is defined in terms of an abstract object model, which represents the available communication services and the external visible behavior of a DeviceNet node.

The DeviceNet Model is application independent. DeviceNet provides the communication services needed by various types of applications. Many of today's lower level industrial control devices must retain their low cost/low resource characteristics even when directly connected to a network. DeviceNet takes this into consideration by defining a specific instance of the DeviceNet Model for communications typically seen in a Master/Slave application. This is referred to as the Predefined Master/Slave Connection Set. Some of the features and functionality of the DeviceNet network are described

Table A.1:

Table 1 - DeviceNet Features and Functionality									
Network Size	Up to 64 Nodes								
Network Length	Selectable end-to-end network distance varies with speed								
	<table border="0"> <thead> <tr> <th>Baud Rate</th> <th>Distance</th> </tr> </thead> <tbody> <tr> <td>125 Kbps</td> <td>500m (1,640 feet)</td> </tr> <tr> <td>250 Kbps</td> <td>250m (820 feet)</td> </tr> <tr> <td>500 Kbps</td> <td>100m (328 feet)</td> </tr> </tbody> </table>	Baud Rate	Distance	125 Kbps	500m (1,640 feet)	250 Kbps	250m (820 feet)	500 Kbps	100m (328 feet)
Baud Rate	Distance								
125 Kbps	500m (1,640 feet)								
250 Kbps	250m (820 feet)								
500 Kbps	100m (328 feet)								
Data Packets	0-8 bytes								
Bus Topology	Linear (trunkline/dropline); power and signal on the same network cable								
Bus Addressing	Peer-to-Peer with Multi-Cast (one-to-many); Multi-Master and Master/Slave special case; polled or change-of-state (exception-based)								
System Features	Removal and replacement of devices from the network under power								

b. DeviceNet™ Protocol

Some of the communication protocol features of DeviceNet™ consist of the following:

A DeviceNet product can behave as a Client, a Server or both.

Master/Slave operation.

Capable of Peer-to-Peer exchange capability exists in which any DeviceNet product can produce and consume messages.

Capable of supporting 64 node addresses

Each node can support an unlimited number of I/O.

DeviceNet requires packets to have identifier fields for the data. The DeviceNet specification defines two different types of messaging. These two different types are I/O Messaging and Explicit Messaging. These messages provide multi-purpose, point-to-point communications paths between two devices. Explicit messages use low priority identifiers and contain the specific meaning of the message in the data field. I/O messages are for time-critical, control-oriented data. They provide a dedicated, special-purpose communication path between a producing application and one or more consuming applications. They are exchanged across single or multi-cast connections and typically use high priority identifiers.

c. DeviceNet Operation

The following restrictions are placed on operations when using an OCS that is configured as a DeviceNet slave.

Currently, communication between the PC and the controller is only possible to the device physically connected to the PCs' serial port. Ladder logic downloads, uploads, monitoring, and configuration **cannot currently take place** over a DeviceNet™ network. The **local node ID and target controller node ID must be the same**.

DeviceNet network nodes are in a range from 0 to 63. The controller is able to observe network responses (polled connections) from any slave to the DeviceNet Master. The first 16-words of these observed responses are made available for mapping on the **Network Input Assignments** page. These correspond to the available nodes 0 to 63 and registers AQQ1 to AQQ16. Node 64 is used for a special case. When data is sent to a controller from a DeviceNet Master (via the polled connection) this data is mapped to node 64. Relative addressing is limited to -64 to +64.

Note: Horner APG manufactures a DeviceNet Master module. The part number is HE693DNT250.

APPENDIX B: DISTRIBUTED CONTROL SYSTEMS (DCS)

1 General

A Distributed Control System (DCS) is defined as a system for the control and monitoring of an industrial process which shares the computer-processing requirement between several processors. With DCS, processing is distributed among a multitude of different processors instead of one very large processing system.

Horner Electric uses a MIMD (multiple instruction, multiple data) parallel processing technique in the CsCAN network. Each processor is capable of sharing data in this system. Typically, the processors are located in a wide variety of devices. These devices may take the form of Micro PLCs, conveyor controllers, operator interfaces, etc. Each of these devices serve a specific function.

It is common in a DCS for several different modules to be physically distributed in some type of arrangement around a plant. This is typically the case with devices connected to plant instrumentation since this greatly reduces plant cabling costs. The name "Distributed Control System" is not a reference to a *physical* layout but rather to the distribution of the processing. The devices in DCS are connected together via a high-speed communication link. Links such as CsCAN and DeviceNet™ are typical in DCS.

2 Attributes Desirable in DCS Design

There are three attributes that are desirable in any DCS design:

a. Ease of Implementation

Modern Distributed Control Systems should be able to implement most control requirements without the need for complex or unusual design.

b. Intuitive to the Operator

The group of individuals that use DCS most frequently are the operators. It is important that applications are designed so that they are operable in a logical and consistent manner and in a way that complements the general operation of a plant.

c. Maintainable

Achieving the required functionality is only part of the solution. The design must also be maintainable. The system should be designed so that it can be maintained without the need for major re-engineering.

Distributed control is becoming ever-increasingly popular. As the presence of networks become more common in industrial automation, finding better ways to use the networks effectively will become much more important. Central to the DCS philosophy, control needs to be distributed out onto the network so that control is implemented where the process actually takes place. With DCS, the overall amount of data on the network is essentially reduced, because only data that has been processed is broadcasted on the network. This allows for more devices to be installed on a network that have a finite bandwidth.

3 Key Factors in Horner's Automation's Distributed Control Systems

All programmable nodes can be programmed via the network. Each node communicates data onto the network that is readable by any other node on the network in the Producer/Consumer network mode. (Also known as Peer-to-Peer Networking). Network medium is flexible. Currently, the Controller Area Network (CAN) is the preferred solution, but it is anticipated that Ethernet will likely be dominant within 1-3 years.

NOTES

INDEX

%AI Registers	18	Fiber Optic Expansion System.....	21
%AIG Registers	19	Firmware Update Wizard.....	34
%AQG Registers	19	FOX	
%D Registers	17	Fiber Optic Expansion System.....	21
%I Registers	18	FOX100 / 110	
%IG Registers	19	Connectors	86
%M Registers	17	Controller Slot position	85
%Q Registers	18	LEDs	86
%QG Registers	19	Specifications / Limitations	85
%R Registers	17	FOX100 Used with SFX.....	90
%S Registers	15	FOX104 / 404	
%SR Registers	15	Dimensions, Hole Pattern.....	79
%T Register	17	Specifications / Limitations	77
Base ID Switches, FOX104 / FOX404	81	FOX104 / FOX404	
Battery Replacement		Fiber Optic Cables	81
Graphic OCS250.....	47	Mounting Instructions	78
OCS1XX / 2XX	41	Mounting Orientation	77
RCS	53	Ports and Connectors	80
Bus Length		FOX110 used with SFX.....	91
CsCAN / DeviceNet	29	Functions of Products	21
Cable		Graphic OCS250	
CsCAN / DeviceNet	28	Battery	47
CAN		Dimensions	44
Features	93	Mounting Orientation	43
Networks	93	Mounting Procedure	44
Operation.....	94	Panel Cut-out	45
Protocol	93	Panel Mounting Clamp.....	46
Wiring and Rules	27	Panel Retaining Clip	46
CAN / DeviceNet		HE500BAT005	41, 47, 53
Network and Wiring	26	Hub, FOX404	80
CsCAN / DeviceNet		IC300FOX104	21
Bus Power and Grounding	29	IC300FOX404	21
CsCAN Network	95	IC300OSW232	12
Features	95	Initial System Menu Screens	56
Operation.....	96	Keypad	
CsCAN Network IDs	61	Graphic OCS250.....	68
CsCAN Network IDs, Hex Conversion	63	OCS1XX	66
Cscape Software	12	OCS2XX	67
Cursor Types	70	LEDs	
Data Fields	18	FOX104 / FOX404	82
DeviceNet Network	96	Graphic OCS250.....	36
Features	96	OCS/RCS	34
Operation.....	98	MAC ID.....	62
Protocol	97	Modem	
Selecting.....	34	Recommended	33
DeviceNet Network ID		Setup.....	31
MAC ID.....	62	Modem Wiring (Cable)	32
Differences, OCS and RCS	21	NEMA Ratings	25
Ethernet		NEMA Torque Specifications	38
FOX100/FOX110 Slot Positon	86	NEMA-Rated Models	22
Fiber Media Converter	22, 85, 90	Network Port	19

OCS 1xx/OCS2xx		Resource Limits.....	14
Mounting Procedures.....	38	Resources.....	13
OCS100-18.....	22	Global Data I/O Registers.....	19
OCS100-19.....	22	HMI Registers.....	17
OCS110-18.....	22	Ladder Code.....	20
OCS110-19.....	22	SmartStack I/O Registers.....	18
OCS1xx.....	9	User Registers.....	17
OCS1XX / 2XX		RS-232	
Orientation.....	37	Graphic OCS250.....	30
OCS1XX/2XX		OCS1XX/200.....	30
Battery Replacement	41	RS-232 Programming	
Dimensions/Panel cut-outs.....	38	Port and Wiring.....	29
Ports, Connectors, Wiring	40	RS-485 (Reserved for Future Use).....	31
OCS200-18.....	22	Scope.....	9
OCS200-19.....	22	Self-Test, System Menu.....	56
OCS210-18.....	22	Set Contrast	57
OCS210-19.....	22	Set FKeys Mode	61
OCS250.....	9	Set Network Baud	57
OCS2xx.....	9	Set Network ID	57
Panel Box		Set RS232 Mode	61
Design Checklist.....	25	Set Time/Date	61
Grounding.....	24	Setting DeviceNet Network IDs	62
Minimum Clearances.....	24	Setting RCS Network ID.....	61
Noise.....	25	SFX100.....	21, 22, 90
Orientation.....	25	SmartStack.....	9
Requirements.....	23	Installing / Removing.....	33
Ventilation / Temperature.....	25	SmartStack Fiber Optic Extension Module.....	22
Ports, Connectors, Wiring.....	26	SmartStack Fiber Optic Extension Module, FOX100 / 110.....	22
Product Description		SmartStack Registers.....	18
Graphic OCS250.....	11	SmartStack, Number of local / remote.....	19
OCS1xx / OCS2xx.....	9	Software, Cscape.....	12
RCS.....	11	Specifications.....	12
SmartStack.....	20	Specifications, FOX104 /FOX404.....	77
Products Covered in Manual.....	9	Specifications, OCS / RCS.....	12
RCS		Status Bar.....	65
Battery Replacement.....	53	Switches, RCS.....	62
Mounting Instructions.....	50	System Menu.....	55
Mounting Orientation.....	49	System Menu (Navigating through)	55
Optional Mounting Bracket (HE800ACC210)	51	System Menu Option Screens.....	57
RCS, CsCAN Network ID.....	61	System Menu Screen Fields (Editing)	55
RCS, MAC ID.....	62	Technical Support.....	22
RCS2xx.....	9	Text Tables.....	18
References, Additional.....	9	Torque Specifications.....	38
Relationship of Products.....	20	User Screens.....	18
Remote Screen and Keypad.....	65	View I/O Slots	60
Remote Text Terminal.....	65	View OCS (RCS) Status	58
Establishing Communications.....	66	View OCS(RCS) Diags	59
Resource Definitions.....	15		