



GE Fanuc Automation

Programmable Control Products

VersaMax® Modules, Power Supplies, and Carriers

User's Manual

GFK-1504K

March 2003

Warnings, Cautions, and Notes as Used in this Publication

Warning

Warning notices are used in this publication to emphasize that hazardous voltages, currents, temperatures, or other conditions that could cause personal injury exist in this equipment or may be associated with its use.

In situations where inattention could cause either personal injury or damage to equipment, a Warning notice is used.

Caution

Caution notices are used where equipment might be damaged if care is not taken.

Note

Notes merely call attention to information that is especially significant to understanding and operating the equipment.

This document is based on information available at the time of its publication. While efforts have been made to be accurate, the information contained herein does not purport to cover all details or variations in hardware or software, nor to provide for every possible contingency in connection with installation, operation, or maintenance. Features may be described herein which are not present in all hardware and software systems. GE Fanuc Automation assumes no obligation of notice to holders of this document with respect to changes subsequently made.

GE Fanuc Automation makes no representation or warranty, expressed, implied, or statutory with respect to, and assumes no responsibility for the accuracy, completeness, sufficiency, or usefulness of the information contained herein. No warranties of merchantability or fitness for purpose shall apply.

The following are trademarks of GE Fanuc Automation North America, Inc.

Alarm Master	Genius	PowerTRAC	Series Six
CIMPLICITY	Helpmate	ProLoop	Series Three
CIMPLICITY 90-ADS	Logicmaster	PROMACRO	VersaMax
CIMSTAR	Modelmaster	Series Five	VersaPoint
Field Control	Motion Mate	Series 90	VersaPro
GENet	PowerMotion	Series One	VuMaster
			Workmaster

Chapter 1	Introduction.....	1-1
	Getting Started	1-1
	The VersaMax® Family of Products	1-3
	CPU Modules for VersaMax PLCs	1-4
	Network Interface Units	1-6
	Power Supplies.....	1-8
	I/O Modules	1-9
	Carriers.....	1-13
	Expansion Modules	1-15
	Communications Modules.....	1-17
	VersaMax General Product Specifications.....	1-19
Chapter 2	Installation Instructions.....	2-1
	Preinstallation Check	2-1
	Conformance to Standards	2-2
	Thermal Considerations	2-2
	DIN Rail and Panel Mounting.....	2-3
	Installing an Expansion Transmitter Module	2-5
	Installing a Power Supply	2-9
	System Wiring Guidelines	2-11
	System Grounding.....	2-15
	Installing Wiring for I/O Devices.....	2-16
	Installing Modules.....	2-36
Chapter 3	Power Supplies	3-1
	IC200PWR001 24VDC Power Supply	3-2
	IC200PWR002 24VDC Expanded 3.3 V Power Supply.....	3-4
	IC200PWR101 120/240VAC Power Supply	3-6
	IC200PWR102 120/240VAC Expanded 3.3V Power Supply.....	3-8
	IC200PWR201 12VDC Power Supply	3-10
	IC200PWR202 12VDC Expanded 3.3 V Power Supply.....	3-12
Chapter 4	Carriers	4-1
	IC200CHS001 Barrier-Style I/O Carrier.....	4-2
	IC200CHS002 Box-Style I/O Carrier	4-5
	IC200CHS003 Connector-Style I/O Carrier	4-8
	IC200CHS005 Spring-Style I/O Carrier	4-11
	IC200CHS022 Compact Box-Style I/O Carrier	4-14
	IC200CHS025 Compact Spring-Style I/O Carrier	4-17
	IC200CHS006 Communications Carrier	4-20

Contents

	IC200PWB001 Power Supply Booster Carrier.....	4-21
Chapter 5	Interposing Terminals and Auxiliary I/O Terminal Strips.....	5-1
	IC200CHS011 Barrier-Style Interposing I/O Terminals.....	5-2
	IC200CHS012 Box-Style Interposing I/O Terminals	5-4
	IC200CHS014 Thermocouple Compensation Box-Style Interposing I/O Terminals.....	5-6
	IC200CHS015 Spring-Style Interposing I/O Terminals	5-8
	IC200CHS101, Main Base IC200CHS102, Expansion Base Disconnect-Style Interposing I/O Terminals.....	5-10
	IC200CHS111, Main Base IC200CHS112, Expansion Base Relay-Style Interposing I/O Terminals.....	5-14
	IC200TBM001 Barrier-Style Auxiliary I/O Terminal Strip.....	5-19
	IC200TBM002 Box-Style Auxiliary I/O Terminal Strip	5-20
	IC200TBM005 Spring-Style Auxiliary I/O Terminal Strip	5-21
Chapter 6	Expansion Modules.....	6-1
	IC200ETM001 Expansion Transmitter Module.....	6-2
	IC200ERM001 Expansion Receiver Module, Isolated	6-7
	IC200ERM002 Expansion Receiver Module, Non-isolated	6-11
Chapter 7	Discrete Input Modules.....	7-1
	IC200MDL140 Input Module, 120VAC 8 Points.....	7-2
	IC200MDL141 Input Module, 240VAC 8 Points.....	7-5
	IC200MDL143 Input Module, 120VAC Isolated 8 Points	7-8
	IC200MDL144 Input Module, 240VAC Isolated 4 Points	7-11
	IC200MDL240 Input Module, 120VAC 16 Points.....	7-14
	IC200MDL241 Input Module, 240VAC16 Points.....	7-18
	IC200MDL243 Input Module, 120VAC Isolated 16 Points	7-21
	IC200MDL244 Input Module, 240VAC Isolated 8 Points	7-25
	IC200MDL631 Input Module, 125VDC Pos/Neg Logic Isolated 8 Points.....	7-28
	IC200MDL632 Input Module, 125VDC Pos/Neg Logic Isolated 16 Points.....	7-31
	IC200MDL635 Input Module, 48VDC Pos/Neg Logic Grouped 16 Points	7-35
	IC200MDL636 Input Module, 48VDC Pos/Neg Logic Grouped 32 Points	7-38
	IC200MDL640 Input Module, 24VDC Pos/Neg Logic 16 Points	7-42
	IC200MDL643 Input Module, 5/12VDC Pos/Neg Logic Grouped 16 Points	7-45
	IC200MDL644 Input Module, 5/12VDC Pos/Neg Logic Grouped 32 Point.....	7-49
	IC200MDL650 Input Module, 24VDC Pos/Neg Logic 32 Points	7-53
Chapter 8	Discrete Output Modules.....	8-1
	IC200MDL329 Output Module, 120VAC 0.5 Amp, Isolated 8 Points.....	8-2
	IC200MDL330 Output Module, 120VAC 0.5 Amp, Isolated 16 Points.....	8-6
	IC200MDL331 Output Module, 120VAC 2.0 Amp, Isolated 8 Points.....	8-10
	IC200MDL730 Output Module, 24VDC Positive Logic 2.0 Amps, w/ESCP 8 Points	8-14

	IC200MDL740 Output Module, 12/24VDC Positive Logic 0.5 Amp, 16 Points	8-17
	IC200MDL741 Output Module, 24VDC Positive Logic 0.5 Amp, w/ESCP 16 Points	8-21
	IC200MDL742 Output Module, 24VDC Positive Logic 0.5 Amp, w/ESCP 32 Points	8-25
	IC200MDL743 Output Module, 5/12/24V DC Negative Logic 0.5 Amp, 16 Points.....	8-29
	IC200MDL744 Output Module, 5/12/24VDC Negative Logic 0.5 Amp, 32 Points.....	8-32
	IC200MDL750 Output Module, 12/24VDC Positive Logic 0.5 Amp, 32 Points	8-36
	IC200MDL930 Output Module, Relay 2.0 Amp Isolated Form A 8 Points.....	8-40
	IC200MDL940 Output Module, Relay 2.0 Amp, Isolated Form A 16 Points.....	8-44
Chapter 9	Discrete Mixed Modules	9-1
	IC200MDD840 Mixed Module, 24VDC Positive Logic Input 20 Points / Output Relay 2.0 Amp 12 Points	9-2
	IC200MDD842 Mixed Module, Output 24VDC Pos. Logic 0.5A Grouped w/ESCP 16 Points / Input 24VDC Pos/Neg Logic Grouped 16 Points	9-6
	IC200MDD843 Mixed Module, 24VDC Positive Logic Input Grouped 10 Points / Output Relay 2.0A per Point Grouped 6 Points	9-12
	IC200MDD844 Mixed Module, Output 12/24VDC Pos. Logic 0.5A 16 Points / Input 24 VDC Pos/Neg Logic Grouped 16 Points.....	9-16
	IC200MDD845 Mixed Module, Output Relay 2.0A Isolated 8 Points / Input 24VDC Pos/Neg Logic Grouped 16 Points	9-21
	IC200MDD846 Mixed Module, Output Relay 2.0A per Pt Isolated 8 Points / Input 120VAC Grouped 8 Points	9-27
	IC200MDD847 Mixed Module, Output Relay 2.0A per Pt Isolated 8 Points / Input 240VAC Grouped 8 Points	9-31
	IC200MDD848 Mixed Module, Output 120VAC 0.5A per Pt Isolated 8 Points / Input 120VAC Grouped 8 Points	9-35
	IC200MDD849 Mixed Module Output Relay 2.0A per Pt Isolated 8 Points / Input 120VAC Isolated 8 Points.....	9-40
	IC200MDD850 Mixed Module, Output Relay 2.0A per Pt Isolated 8 Points / Input 240VAC Isolated 4 Points.....	9-44
	IC200MDD851 Mixed Module, Output 12/24VDC Positive Logic Grouped 16 Points / Input 5/12VDC Pos/Neg Logic Grouped 16 Points	9-48
Chapter 10	Analog Input Modules	10-1
	IC200ALG230 Analog Input Module, 12 Bit Voltage/Current 4 Channels.....	10-2
	IC200ALG240 Analog Input Module, 16 Bit Voltage/Current, 1500VAC Isolation, 8 Channels	10-9
	IC200ALG260 Analog Input Module, 12 Bit Voltage/Current 8 Channels.....	10-17
	IC200ALG261 Analog Input Module, 15 Bit Differential Voltage 8 Channels.....	10-24
	IC200ALG262 Analog Input Module, 15 Bit Differential Current 8 Channels.....	10-29
	IC200ALG263 Analog Input Module, 15 Bit Voltage 15 Channels	10-36
	IC200ALG264 Analog Input Module, 15 Bit Current 15 Channels	10-42
Chapter 11	Analog Output Modules	11-1
	IC200ALG320 Analog Output Module, 12 Bit Current, 4 Channels.....	11-2

Contents

	IC200ALG321 Analog Output Module, 12 Bit Voltage 0 to 10VDC 4 Channels	11-9
	IC200ALG322 Analog Output Module, 12 Bit Voltage -10 to +10VDC 4 Channels.....	11-15
	IC200ALG325 Analog Output Module, 13 Bit Voltage 8 Channels	11-21
	IC200ALG326 Analog Output Module, 13 Bit Current, 8 Channels.....	11-28
	IC200ALG327 Analog Output Module, 13 Bit Voltage 12 Channels	11-34
	IC200ALG328 Analog Output Module, 13 Bit Current, 12 Channels.....	11-41
	IC200ALG331 Analog Output Module, 16 Bit Voltage/Current, 1500VAC Isolation, 4 Channels	11-48
Chapter 12	Analog Mixed I/O Modules	12-1
	IC200ALG430 Analog Mixed Module, 12 Bit Input Current 4 Channels and Output Current 2 Channels	12-2
	IC200ALG431 Analog Mixed Module, 12 Bit 0 to 10VDC Input 4 Channels and Output 2 Channels	12-9
	IC200ALG432 Analog Mixed Module, 12 Bit +/-10VDC Input 4 Channels and Output 2 Channels	12-16
Chapter 13	Mixed Discrete/High-speed Counter Module	13-1
	IC200MDD841 Mixed Module, 24VDC Positive Logic Input 20 Points / Output 12 Point / (4) High Speed Counter, PWM, or Pulse Train Configurable Points	13-2
Chapter 14	Temperature-Sensing Modules	14-1
	IC200ALG620 Analog Input, 16 Bit RTD, 4 Channels.....	14-2
	IC200ALG630 Analog Input, 16 Bit Thermocouple, 7 Channels.....	14-10
Chapter 15	Accessories	15-1
	IC200ACC301 I/O Filler Module	15-2
	IC200ACC302 Input Simulator	15-3
	IC200ACC303 I/O Shorting Bar.....	15-4
Appendix A	Panel Mounting Dimensions.....	A-1
	Thermal Considerations	A-2
	Module Space Requirements.....	A-3
	Module Sizes.....	A-4
	Panel-Mounting Details	A-5
	Example Mounting Dimensions	A-11
Appendix B	Relay Contact Ratings	B-1
Appendix C	Power Supply Load Requirements	C-1
Appendix D	I/O Module Keying Summary	D-1

Getting Started

Read this chapter first to learn about the basics of VersaMax I/O®. To locate detailed information, check the **Guide to the VersaMax Document Set** below.

Guide to the VersaMax Document Set

This manual contains descriptions of the many VersaMax I/O and option modules, power supplies, and carriers.

Installation procedures are described in Chapter 2.

The rest of the chapters in this manual describe the wide variety of VersaMax I/O modules, carriers, and accessories that are available.

- Power Supplies: chapter 3
- Carriers: chapter 4
- Interposing Terminals and Terminal Strips: chapter 5
- Expansion Modules: chapter 6
- Discrete Input Modules: chapter 7
- Discrete Output Modules: chapter 8
- Discrete Mixed Modules: chapter 9
- Analog Input Modules: chapter 10
- Analog Output Modules: chapter 11
- Analog Mixed Modules: chapter 12
- Discrete Mixed/High Speed Counter Module: chapter 13
- Temperature-sensing Modules: chapter 14
- Accessories: chapter 15

The appendixes to this manual contain detailed reference information.

Other VersaMax Manuals

For more information about VersaMax products, consult the manuals described below.

<p><i>VersaMax PLC System Manual</i> (catalog number GFK-1503)</p>	<p>Describes the installation and operation of the PLC System. This manual also contains general information about CPU operation and program features.</p>
<p><i>VersaMax Ethernet Network Interface Unit User's Manual</i> (catalog number GFK-1860)</p>	<p>Describes the installation and operation of the Ethernet NIU. The Ethernet NIU interfaces an I/O station of VersaMax modules to an Ethernet Network.</p>
<p><i>VersaMax DeviceNet Modules User's Manual</i> (catalog number GFK-1533)</p>	<p>Describes the installation and operation of the DeviceNet NIU and DeviceNet Network Communications Module.</p> <p>The DeviceNet NIU interfaces an I/O station of VersaMax modules to a DeviceNet Network. It operates as a slave on the network.</p> <p>The DeviceNet Network Communications Module can operate as a master or slave on the DeviceNet network.</p>
<p><i>VersaMax Profibus Network Modules User's Manual</i> (catalog number GFK-1534)</p>	<p>Describes the installation and operation of the Profibus Network Interface Unit and Profibus Network Slave Module.</p> <p>The Profibus NIU interfaces an I/O station of VersaMax modules to a Profibus Network. It operates as a slave on the network.</p> <p>The Profibus Network Slave Module operates as a slave on the Profibus network.</p>
<p><i>VersaMax Genius Network Interface Unit User's Manual</i> (catalog number GFK-1535)</p>	<p>Describes the installation and operation of the Genius NIU. The Genius NIU interfaces an I/O station of VersaMax modules to a Genius Network.</p>
<p><i>VersaMax AS-i Network Master Module User's Manual</i> (catalog number GFK-1697)</p>	<p>Describes the installation and operation of the VersaMax AS-Interface Network Master module (IC200BEM104), which can be used to interface a VersaMax PLC or I/O station NIU to an AS-i network.</p>

The VersaMax[®] Family of Products

The VersaMax family of products provides universally-distributed I/O that spans PLC and PC-based architectures. Designed for industrial and commercial automation, VersaMax I/O provides a common, flexible I/O structure for local and remote control applications. The Versamax PLC provides big-PLC power with a full range of I/O and option modules. VersaMax I/O Stations with Network Interface Modules make it possible to add the flexibility of VersaMax I/O to other types of networks. VersaMax meets UL, CUL, CE, Class1 Zone 2 and Class I Division 2 requirements.

As a scaleable automation solution, VersaMax I/O combines compactness and modularity for greater ease of use. The 70-mm depth and small footprint of VersaMax I/O enables easy, convenient mounting as well as space-saving benefits. Modules can accommodate up to 32 points of I/O each.

The compact, modular VersaMax products feature DIN-rail mounting with up to eight I/O and option modules per “rack” and up to 8 racks per VersaMax PLC or VersaMax I/O Station system. Expansion racks can be located up to 750 meters from the main VersaMax PLC or VersaMax I/O Station rack. Expansion racks can include any VersaMax I/O, option, or communications module.

VersaMax provides automatic addressing that can eliminate traditional configuration and the need for hand-held devices. Multiple field wiring termination options provide support for two, three, and four-wire devices.

For faster equipment repair and shorter Mean-Time-To-Repair, the hot insertion feature enables addition and replacement of I/O modules while a machine or process is running and without affecting field wiring.

CPU Modules for VersaMax PLCs

A VersaMax PLC consists of a group of VersaMax modules with a VersaMax CPU and attached power supply in the first position.

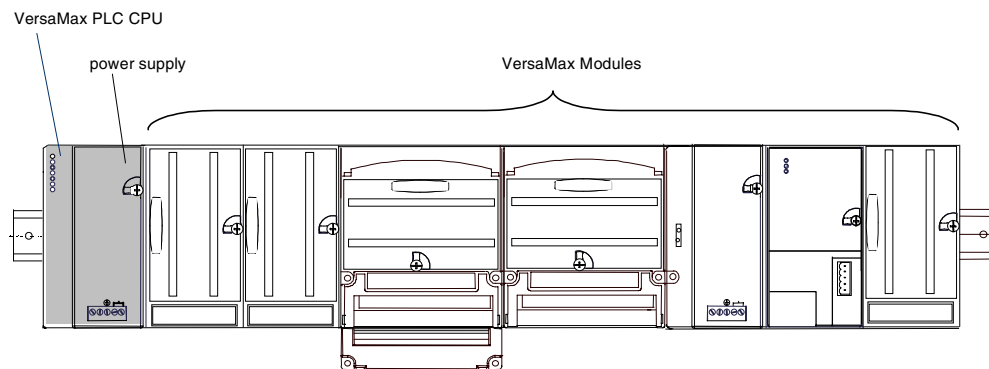

All VersaMax CPUs provide powerful PLC functionality. They are designed to serve as the system controller for up to 64 modules with up to 2048 I/O points. Two serial ports provide RS-232 and RS-485 interfaces for SNP slave and RTU slave communications.

VersaMax CPUs are described in the *VersaMax PLC User's Manual* (GFK-1503). GFK-1503 also provides programming information for the VersaMax PLC.

Basic CPU Features

- Programming in Ladder Diagram, Sequential Function Chart, and Instruction List
- Floating point (real) data functions
- Non-volatile flash memory for program storage
- Battery backup features for program, data, and time of day clock
 - Super capacitor provides power to memory for 1 hour
 - Over 1 hour, backup battery protects memory contents up to 6 months.
 - Backup battery has shelf life of 5 years when not in use.
- Run/Stop switch
- Embedded RS-232 and RS-485 communications

Available VersaMax CPUs

CPU with Two Serial Ports, 34kB of Configurable Memory	IC200CPU001
CPU with Two Serial Ports, 42kB of Configurable Memory	IC200CPU002
CPU with Two Serial Ports, 64kB of Configurable Memory	IC200CPU005
CPU with Two Serial Ports and Embedded Ethernet Interface, 64kB of Configurable Memory	IC200CPUE05

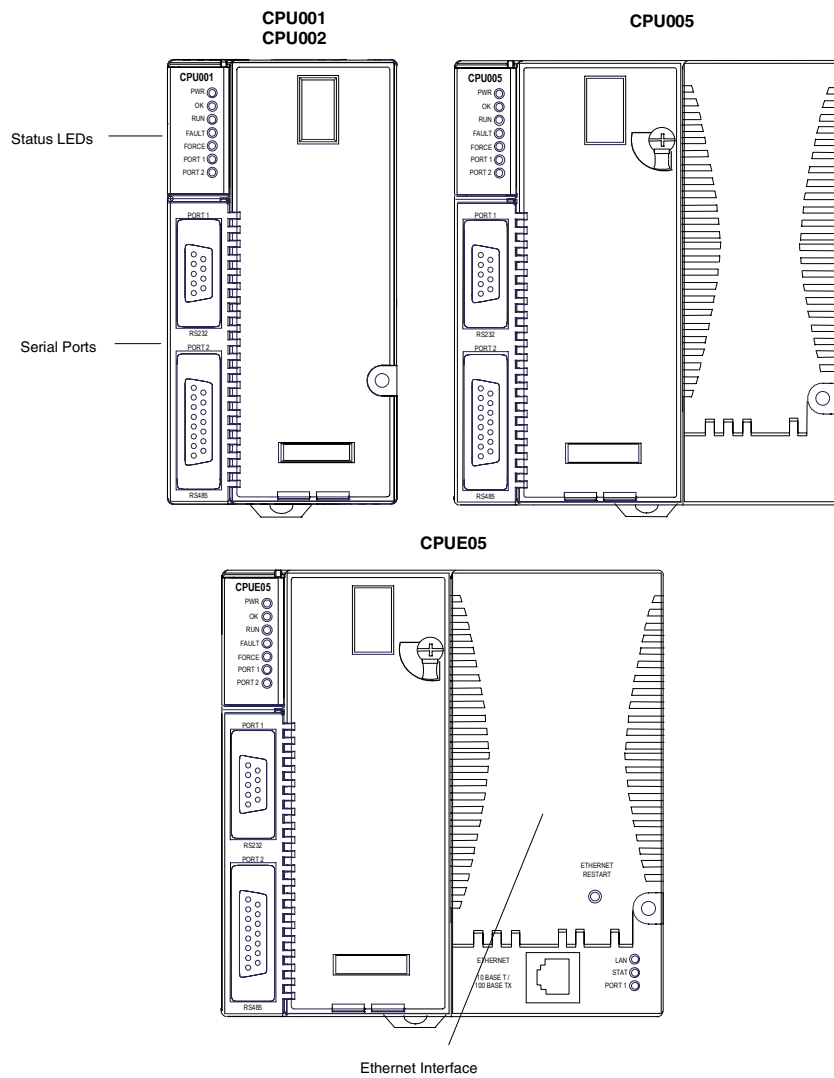

Network Interface Units

A VersaMax I/O Station consists of a group of VersaMax modules with a VersaMax Network Interface Unit module and attached power supply in the first position.

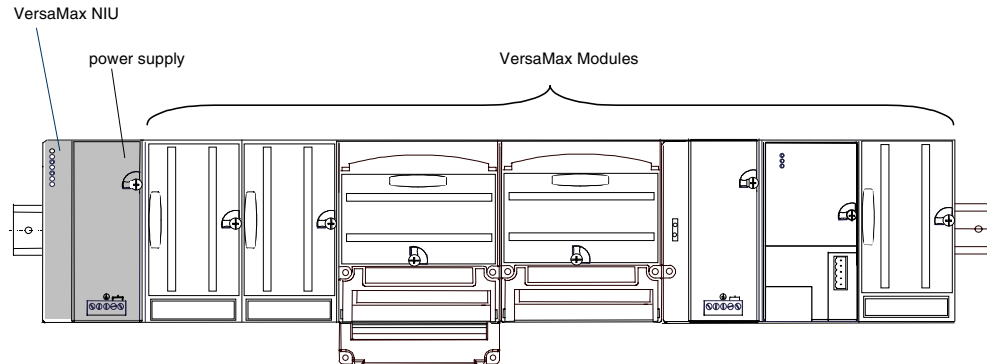

The Network Interface Unit provides I/O scanning and a communications interface, allowing a group of VersaMax modules to function as an I/O station on a communications bus. The power supply on the NIU provides power for the modules in the I/O Station. Additional “booster” power supplies can be included in the system if needed for modules with high current requirements.

A Network Interface Unit module has connectors appropriate for its communications network type and status LEDs. NIUs also have rotary dials that can be used to set communications ID information and other parameters. A Genius NIU is shown below.

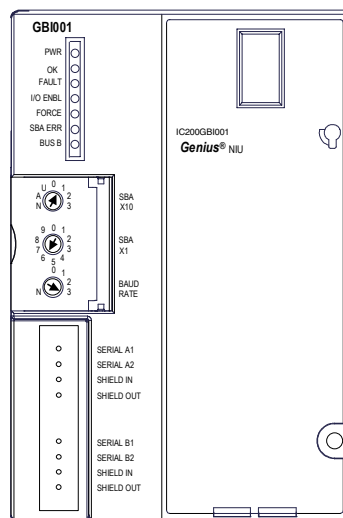

Available VersaMax NIUs

Ethernet Network Interface Unit	IC200EBI001
Profibus Network Interface Unit	IC200PBI001
Genius Network Interface Unit	IC200GBI001
DeviceNet Network Interface Unit	IC200DBI001

Ethernet NIU

The Ethernet Network Interface Unit (IC200EBI001) serves as the connection point between VersaMax I/O modules and a single 10/100Base-T Ethernet network. The NIU supports Modbus/TCP protocol.

For information about the Ethernet Network Interface Unit, refer to the *VersaMax System Ethernet Network Communications User's Manual* (GFK-1860).

DeviceNet NIU

The DeviceNet Network Interface Unit (IC200DBI001) is a DeviceNet slave module. DeviceNet supports a variety of communication structures including peer to peer, multi-master and master/slave with broadcasting capabilities. Up to 64 nodes can be connected to a DeviceNet network without bridging or routing.

For information about the DeviceNet Network Interface Unit, refer to the *VersaMax System DeviceNet Network Communications User's Manual* (GFK-1533).

Profibus NIU

The Profibus Network Interface Unit (IC200PBI001) operates as a slave on a Profibus-DP Network, automatically exchanging I/O, status, control, and diagnostic data with a master device. The NIU is capable of handling up to 375 bytes of I/O data, consisting of up to 244 bytes of discrete and analog input data and up to 244 bytes of discrete and analog output data. The system host can be any device capable of operating as a bus master.

For information about the Profibus-DP Network Interface Unit, refer to the *VersaMax System Profibus Network Modules User's Manual* (GFK-1534, revision A or later).

Genius NIU

The Genius Network Interface Unit (IC200GBI001) operates as a device on a Genius bus. The NIU is capable of handling up to 128 bytes of discrete and analog input data and 128 bytes of discrete and analog output data. The system host can be any PLC or computer capable of controlling the Genius bus.

For information about the Genius Network Interface Unit, refer to the *VersaMax System Genius Network Interface Unit User's Manual* (GFK-1535).

Power Supplies

An AC or DC Power Supply module installs directly on the CPU or NIU. The Power Supply provides +5V and +3.3V power to the modules in the station. Additional power supplies can be installed on special booster carriers if needed for systems where the number of modules creates the need for a booster. The AC or DC Power Supply on the CPU or NIU and the Power Supply that resides on the Booster Carrier must share the same external power source.

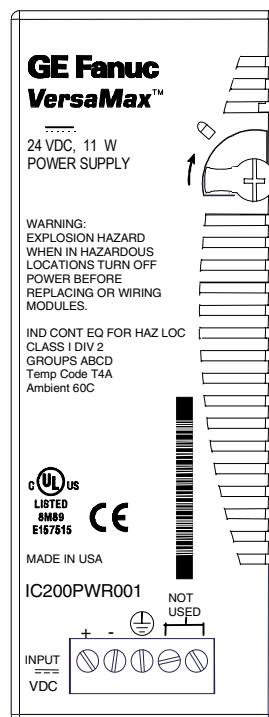

Available Power Supplies and Carrier

The following VersaMax power supplies and carrier are available:

24VDC Power Supply	IC200PWR001
24VDC Expanded 3.3V Power Supply	IC200PWR002
120/240VAC Power Supply	IC200PWR101
120/240VAC Expanded 3.3V Power Supply	IC200PWR102
12VDC Power Supply	IC200PWR201
12VDC Expanded 3.3V Power Supply	IC200PWR202
Power Supply Booster Carrier	IC200PWB001

Power supplies are described in chapter 3 of this manual.

I/O Modules

VersaMax IO and option modules are approximately 110mm (4.3in) by 66.8mm (2.63in) in size. Modules can be mounted either horizontally or vertically on several types of available I/O Carriers. Modules are 50mm (1.956 in) in depth, not including the height of the carrier or the mating connectors.

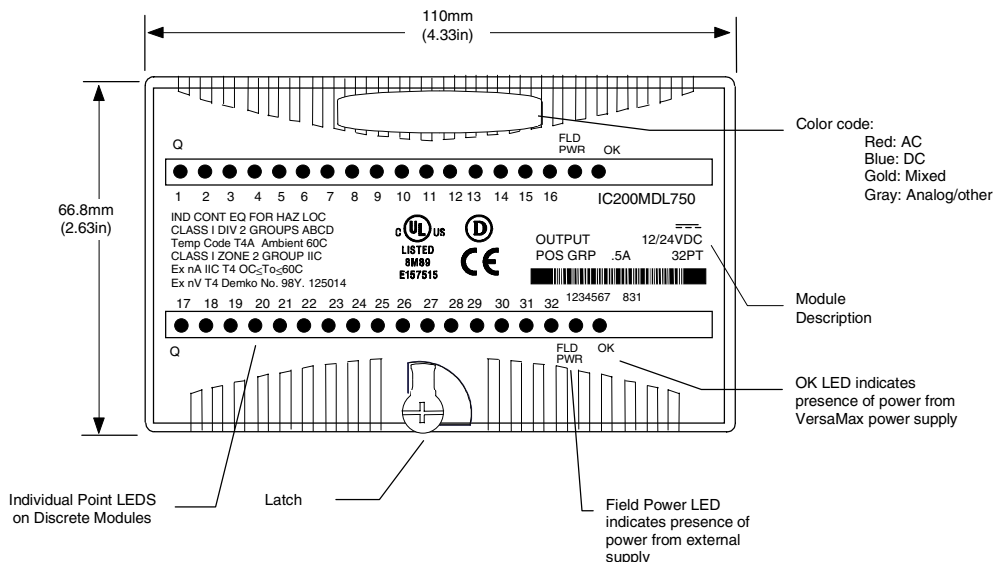

VersaMax I/O modules are described in this manual. They are grouped into chapters by module type. For more information about a specific module, please refer to the Table of Contents or Index to locate the module description.

Discrete Module Point LEDs

Individual point LEDs on discrete modules provide status information at a glance. Laser markings on the module identify the LEDs. The positions of the point LEDs always correspond to the module's wiring diagram, whether the module is simple:

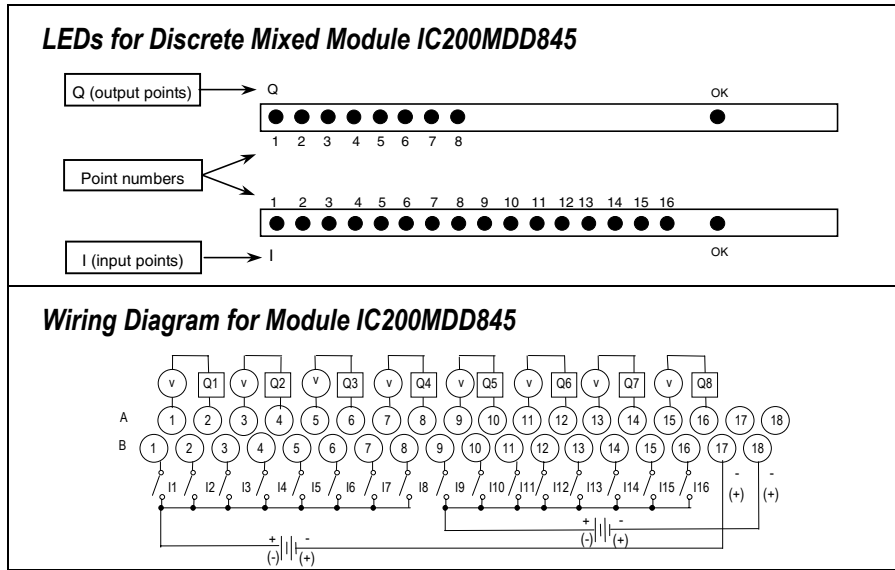

or more complex:

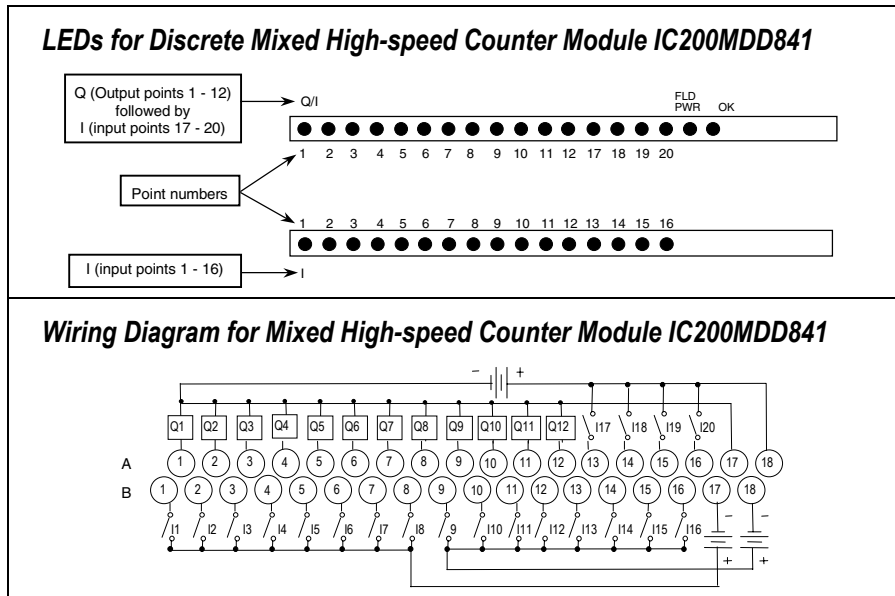

Available I/O Modules

The following types of VersaMax I/O Modules are available:

Discrete Input Modules	
Input Module, 120VAC 8 Points	IC200MDL140
Input Module, 240VAC 8 Points	IC200MDL141
Input Module, 120VAC Isolated 8 Points	IC200MDL143
Input Module, 240VAC Isolated 4 Points	IC200MDL144
Input Module, 120VAC 16 Points	IC200MDL240
Input Module, 240VAC 16 Points	IC200MDL241
Input Module, 120VAC Isolated 16 Points	IC200MDL243
Input Module, 240VAC Isolated 8 Points	IC200MDL244
Input Module, 125VDC Positive/Negative Logic Isolated 8 Points	IC200MDL631
Input Module, 125VDC Positive/Negative Logic Isolated 16 Points	IC200MDL632
Input Module, 48VDC Positive/Negative Logic Grouped 16 Points	IC200MDL635
Input Module, 48VDC Positive/Negative Logic Grouped 32 Points	IC200MDL636
Input Module, 24VDC Positive/Negative Logic 16 Points	IC200MDL640
Input Module, 5/12VDC Positive/Negative Logic Grouped 16 Points	IC200MDL643
Input Module, 5/12VDC Positive/Negative Logic Grouped 32 Point	IC200MDL644
Input Module, 24VDC Positive/Negative Logic (32 Points)	IC200MDL650
Discrete Output Modules	
Output Module, 120VAC 0.5 Amp, Isolated 8 Points	IC200MDL329
Output Module, 120VAC 0.5 Amp, Isolated 16 Points	IC200MDL330
Output Module, 120VAC 2.0 Amp, Isolated 8 Points	IC200MDL331
Output Module, 24VDC Positive Logic 2.0 Amps, w/ESCP 8 Points	IC200MDL730
Output Module, 12/24VDC Positive Logic 0.5 Amp, 16 Points	IC200MDL740
Output Module, 24VDC Positive Logic 0.5 Amp, w/ESCP 16 Points	IC200MDL741
Output Module, 24VDC Positive Logic 0.5 Amp, w/ESCP 32 Points	IC200MDL742
Output Module, 5/12/24V DC Negative Logic 0.5 Amp, 16 Points	IC200MDL743
Output Module, 5/12/24VDC Negative Logic 0.5 Amp, 32 Points	IC200MDL744
Output Module, 12/24VDC Positive Logic 0.5 Amp, 32 Points	IC200MDL750
Output Module, Relay 2.0 Ampt Isolated Form A 8 Points	IC200MDL930
Output Module, Relay 2.0 Amp, Isolated Form A 16 Points	IC200MDL940

Discrete Mixed I/O Modules	
Mixed Module, 24VDC Positive Logic Input 20 Points / Output Relay 2.0 Amp 12 Points	IC200MDD840
Mixed Module, 24VDC Positive Logic Input 20 Points / Output 12 Point / (4) High Speed Counter, PWM, or Pulse Train Configurable Points	IC200MDD841
Mixed Module, Output 24VDC Pos. Logic 0.5A Grouped w/ESCP 16 Points / Input 24VDC Pos/Neg Logic Grouped 16 Points	IC200MDD842
Mixed Module, 24VDC Positive Logic Input Grouped 10 Points / Output Relay 2.0A per Point Grouped 6 Points	IC200MDD843
Mixed Module, Output 12/24VDC Pos. Logic 0.5A 16 Points / Input 24 VDC Pos/Neg Logic Grouped 16 Points	IC200MDD844
Mixed Module, Output Relay 2.0A Isolated 8 Points / Input 24VDC Pos/Neg Logic Grouped 16 Points	IC200MDD845
Mixed Module, Output Relay 2.0A per Pt Isolated 8 Points / Input 120VAC Grouped 8 Points	IC200MDD846
Mixed Module, Output Relay 2.0A per Pt Isolated 8 Points / Input 240VAC Grouped 8 Points	IC200MDD847
Mixed Module, Output 120VAC 0.5A per Pt Isolated 8 Points / Input 120VAC Grouped 8 Points	IC200MDD848
Mixed Module Output Relay 2.0A per Pt Isolated 8 Points / Input 120VAC Isolated 8 Points	IC200MDD849
Mixed Module, Output Relay 2.0A per Pt Isolated 8 Points / Input 240VAC Isolated 4 Points	IC200MDD850
Mixed Module, Output 12/24VDC Pos. Grouped 16 Pts / Input 5/12VDC Pos/Neg Grp 16 Pts	IC200MDD851
Analog Input Modules	
Analog Input Module, 12 Bit Voltage/Current 4 Channels	IC200ALG230
Analog Input Module, 16 Bit Voltage/Current, 1500VAC Isolation, 8 Channels	IC200ALG240
Analog Input Module, 12 Bit Voltage/Current 8 Channels	IC200ALG260
Analog Input Module, 15 Bit Voltage Differential 8 Channels	IC200ALG261
Analog Input Module, 15 Bit Current Differential 8 Channels	IC200ALG262
Analog Input Module, 15 Bit Voltage 15 Channels	IC200ALG263
Analog Input Module, 15 Bit Current 15 Channels	IC200ALG264
Analog Input Module, 16 Bit RTD, 4 Channels	IC200ALG620
Analog Input Module, 16 Bit Thermocouple, 7 Channels	IC200ALG630
Analog Output Modules	
Analog Output Module, 12 Bit Current, 4 Channels	IC200ALG320
Analog Output Module, 12 Bit Voltage 0 to 10VDC 4 Channels	IC200ALG321
Analog Output Module, 12 Bit Voltage -10 to +10VDC 4 Channels	IC200ALG322
Analog Output Module, 13 Bit Voltage 8 Channels	IC200ALG325
Analog Output Module, 13 Bit Current 8 Channels	IC200ALG326
Analog Output Module, 13 Bit Voltage 12 Channels	IC200ALG327
Analog Output Module, 13 Bit Current 12 Channels	IC200ALG328
Analog Output Module, 16 Bit Voltage/Current, 1500VAC Isolation, 4 Channels	IC200ALG331
Analog Mixed I/O Modules	
Analog Mixed Module, 12 Bit Input Current 4 Channels and Output Current 2 Channels	IC200ALG430
Analog Mixed Module, 12 Bit 0 to 10VDC Input 4 Channels and Output 2 Channels	IC200ALG431
Analog Mixed Module, 12 Bit +/-10VDC Input 4 Channels and Output 2 Channels	IC200ALG432

Carriers

Carriers provide mounting, backplane communications, and field wiring connections for all types of VersaMax modules. I/O modules can be installed on carriers or removed without disturbing field wiring.

There are three basic I/O Carrier types:

- Terminal-style I/O carriers. Modules mount parallel to the DIN rail.
- Compact Terminal-style I/O Carriers. Modules mount perpendicular to the DIN rail.
- Connector-style I/O Carriers. Modules mount perpendicular to the DIN rail. These carriers are normally used with Interposing I/O Terminals. One type of Interposing I/O Terminals is illustrated below; other types are also available.

See chapter 4 for information about VersaMax I/O Carriers.

Terminal-style I/O carriers have 36 individual terminals for direct connection of field wiring. Auxiliary I/O Terminal Strips are available for applications requiring additional wiring terminals. Chapter 5 of this manual describes the VersaMax Interposing Terminals and Auxiliary I/O Terminal Strips.

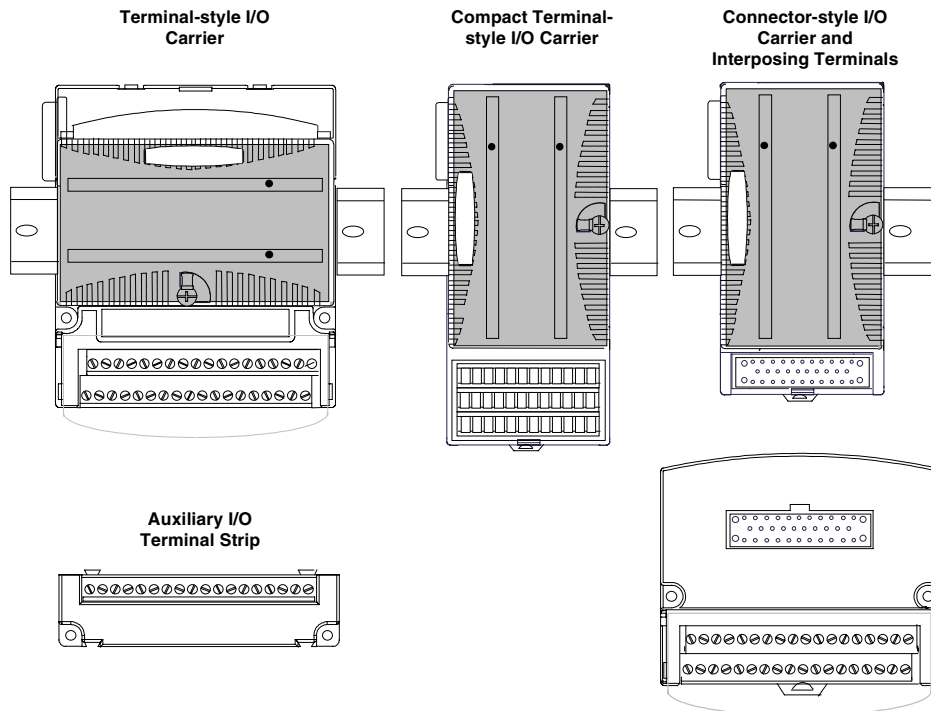

Available I/O Carriers and Terminal Strips

The following types of I/O Carriers, terminals, and cables are available:

Terminal-Style I/O Carriers	
Barrier-Style Terminal I/O Carrier	IC200CHS001
Box-Style Terminal I/O Carrier	IC200CHS002
Spring-Style Terminal I/O Carrier	IC200CHS005
Compact Terminal-Style I/O Carriers	
Compact Box-Style I/O Carrier	IC200CHS022
Compact Spring-Style I/O Carrier	IC200CHS025
Connector-Style I/O Carrier	
Connector-Style I/O Carrier	IC200CHS003
Interposing Terminals for use with Connector-Style Carrier	
Barrier-Style Interposing I/O Terminals	IC200CHS011
Box-Style Interposing I/O Terminals	IC200CHS012
Thermocouple-Style Interposing I/O Terminals	IC200CHS014
Spring-Style Interposing I/O Terminals	IC200CHS015
Disconnect-Style Interposing I/O Terminals, Main Base	IC200CHS101
Disconnect-Style Interposing I/O Terminals, Expansion Base	IC200CHS102
Relay-Style Interposing I/O Terminals, Main Base	IC200CHS111
Relay-Style Interposing I/O Terminals, Expansion Base	IC200CHS112
Cables for use with Connector-Style I/O Carriers	
2 connectors, 0.5m, no shield	IC200CBL105
2 connectors, 1.0m, no shield	IC200CBL110
2 connectors, 2.0m, no shield	IC200CBL120
1 connector, 3.0m, no shield	IC200CBL230
Auxiliary I/O Terminal Strips for use with Terminal-style I/O Carriers and Interposing Terminals	
Barrier-Style Auxiliary I/O Terminal Strip	IC200TBM001
Box-Style Auxiliary I/O Terminal Strip	IC200TBM002
Spring-Style Auxiliary I/O Terminal Strip	IC200TBM005
Other Carriers	
Communications Carrier	IC200CHS006
Power Supply Booster Carrier	IC200PWB001

Expansion Modules

There are two basic types of VersaMax I/O expansion systems, Multi-Rack and Two-Rack Local:

- Multi-Rack:** A VersaMax PLC or NIU I/O Station with an Expansion Transmitter Module (IC200ETM001) and one to seven expansion “racks”, each with an Expansion Receiver Module (IC200ERM001 or IC200ERM002). If all the Expansion Receivers are the Isolated type (IC200ERM001), the maximum overall cable length is 750 meters. If the expansion bus includes any non-isolated Expansion Receivers (IC200ERM002), the maximum overall cable length is 15 meters.

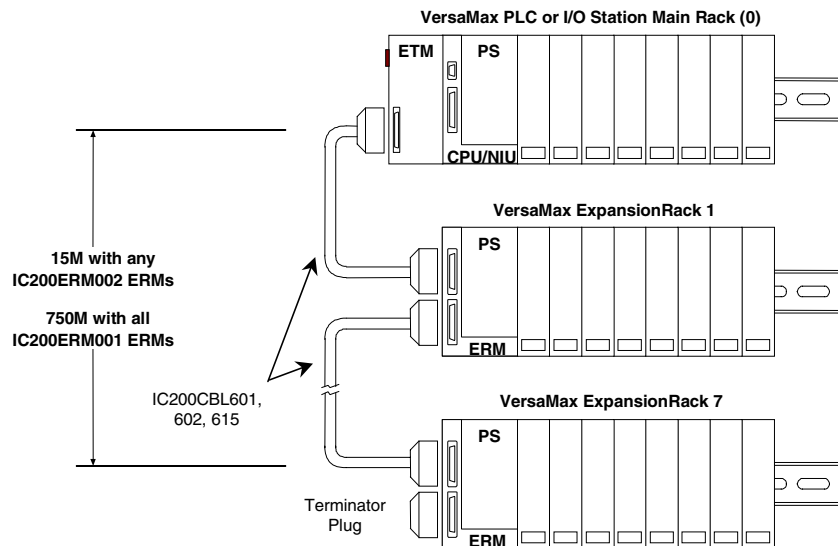

- Two-Rack Local:** A PLC or NIU I/O Station connected directly to one expansion rack with non-isolated Expansion Receiver Module (IC200ERM002). Maximum cable length is 1 meter.

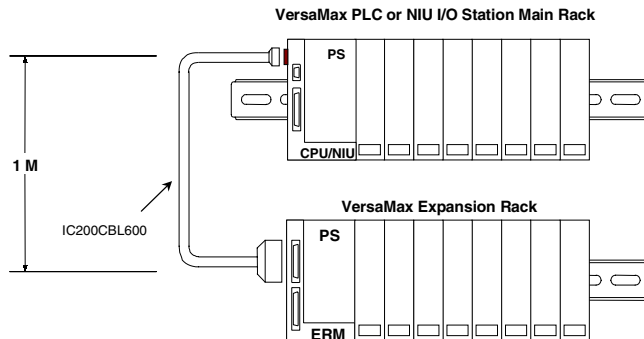

VersaMax Modules for Expansion Racks

All types of VersaMax I/O and communications modules can be used in expansion racks. Some VersaMax analog modules require specific module revisions as listed below:

Module	Module Revision
IC200ALG320	B or later
IC200ALG321	B or later
IC200ALG322	B or later
IC200ALG430	C or later
IC200ALG431	C or later
IC200ALG432	B or later

Available Expansion Modules

The following Expansion Modules and related products are available:

Expansion Modules	
Expansion Transmitter Module	IC200ETM001
Expansion Receiver Module, Isolated	IC200ERM001
Expansion Receiver Module, Non-isolated	IC200ERM002
Cables	
Expansion Cable, 1 meter	IC200CBL601
Expansion Cable, 2 meters	IC200CBL602
Expansion Cable, 15 meters	IC200CBL615
Firmware Update Cable	IC200CBL002
Terminator Plug (included with ETM)	IC200ACC201
Connector Kit	IC200ACC302

See chapter 6 for information about VersaMax Expansion modules.

Communications Modules

Communications modules provide additional flexibility for VersaMax systems.

These communications modules install on a VersaMax Communications Carrier. Power for the communications module comes from the main system power supply or from a booster supply as shown below.

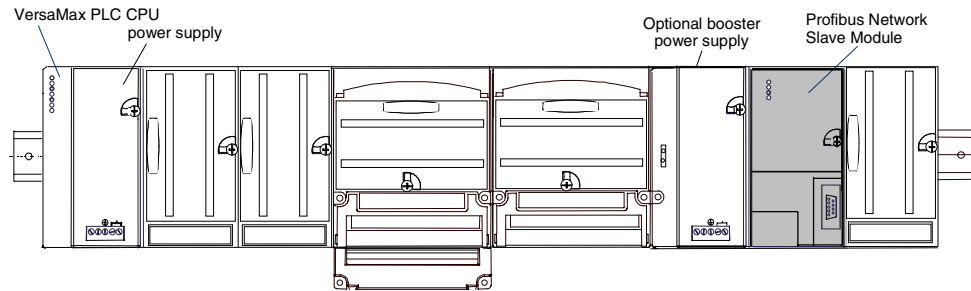

Available VersaMax PLC Communications Modules

The following VersaMax PLC communications modules are available:

Communications Modules	
Profibus-DP Network Slave Module	IC200BEM002
DeviceNet Network Control Module	IC200BEM103
Asi Network Master Module	IC200BEM104
Communications Carrier	IC200CHS006

For information about the Communications Carrier, please see chapter 4.

Profibus-DP Network Slave Module

The Profibus-DP Network Slave Module (IC200BEM002) is a communications module that exchanges PLC reference table data on the Profibus network. The VersaMax PLC CPU can read and write this data as though it were conventional bit- and word-type I/O data.

Multiple Profibus-DP Network Slave Modules may be used in the same VersaMax PLC. Each one can read up to 244 bytes of data from the network, and send up to 244 bytes of output data. The total amount of combined inputs and outputs is 384 bytes.

For information about the Profibus-DP Network Slave Module, refer to the *VersaMax System Profibus Network Modules User's Manual* (GFK-1534, revision A or later).

DeviceNet Network Control Module

The DeviceNet Network Control Module (IC200BEM103) is a communications module that can be configured to operate as a master, as a slave, or as both simultaneously. It can exchange up to 512 bytes of input data and 512 bytes of output data with other devices on the DeviceNet network. The VersaMax PLC CPU can read and write this data as though it were conventional bit- and word-type I/O data.

The Network Control Module operates as a Group 2 Only Client (master) and can communicate only with Group 2 Slave devices. It can also operate as a Group 2 Only or a UCMM-capable Server (slave), or as a master and slave simultaneously.

For information about the DeviceNet Network Control Module, refer to the *VersaMax System DeviceNet Network Communications User's Manual* (GFK-1533).

Asi Network Master Module

The VersaMax AS-Interface Network Master (IC200BEM104) conforms to the AS-Interface Specification for the master AS-Interface protocol. It can be used to connect a VersaMax PLC or I/O station NIU to an Actuator-Sensor network.

The AS-Interface module supports communications with up to 31 slave devices, exchanging to exchange up to 4 bits of input data and 4 bits of output data per slave address on the Actuator-Sensor network.

For information about the AS-Interface Network Master Module, refer to the *VersaMax System ASI Network Communications User's Manual* (GFK-1697).

VersaMax General Product Specifications

VersaMax products should be installed and used in conformance with product-specific guidelines as well as the following specifications:

Environmental		
Vibration	IEC68-2-6	1G @57-150Hz, 0.012in p--p @10-57Hz
Shock	IEC68-2-27	15G, 11ms
Operating Temp.		0 deg C to +60 deg C ambient -40 deg C to +60 deg C ambient for I/O carriers, interposing I/O terminals, and auxiliary I/O terminals
Storage Temp.		-40 deg C to +85 deg C
Humidity		5% to 95%, noncondensing
Enclosure Protection	IEC529	Steel cabinet per IP54: protection from dust & splashing water
EMC Emission		
Radiated, Conducted	CISPR 11/EN 55011	Industrial Scientific & Medical Equipment (Group 1, Class A)
	CISPR 22/EN 55022	Information Technology Equipment (Class A)
	FCC 47 CFR 15	referred to as FCC part 15, Radio Devices (Class A)
EMC Immunity		
Electrostatic Discharge	EN 61000-4-2	8KV Air, 4KV Contact
RF Susceptibility	EN 61000-4-3	10V _{rms} /m, 80Mhz to 1000Mhz, 80% AM
	ENV 50140/ENV 50204	10V _{rms} /m, 900MHz +/-5MHZ 100%AM with 200Hz square wave
Fast Transient Burst	EN 61000-4-4	2KV: power supplies, 1KV: I/O, communication
Surge Withstand	ANSI/IEEE C37.90a	Damped Oscillatory Wave: 2.5KV: power supplies, I/O [12V-240V]
	IEC255-4	Damped Oscillatory Wave: Class II, power supplies, I/O [12V-240V]
	EN 61000-4-5	2 kV cm(P/S); 1 kV cm (I/O and communication modules)
Conducted RF	EN 61000-4-6	10V _{rms} , 0.15 to 80Mhz, 80%AM
Isolation		
Dielectric Withstand	UL508, UL840, IEC664	1.5KV for modules rated from 51V to 250V
Power Supply		
Input Dips, Variations	EN 61000-4-11	During Operation: Dips to 30% and 100%, Variation for AC +/-10%, Variation for DC +/-20%

This section gives basic installation instructions.

- Preinstallation Check
- Conformance to Standards
- Thermal Clearance
- DIN Rail and Panel Mounting
- Installing Carriers
- Expansion System Installation
- Installing a Power Supply
- System Wiring Guidelines
- System Grounding
- Installing Wiring for I/O Devices
- Installing Modules

Preinstallation Check

Carefully inspect all shipping containers for damage during shipping. If any part of the system is damaged, notify the delivery service immediately. The damaged shipping container should be saved as evidence for inspection by the delivery service. As the consignee, it is your responsibility to register a claim with the delivery service for damage incurred during shipment. However, GE Fanuc will fully cooperate with you, should such action be necessary. After unpacking the VersaMax modules and other equipment, record all serial numbers. Serial numbers are required if you should need to contact Product Service during the warranty period of the equipment. All shipping containers and all packing material should be saved should it be necessary to transport or ship any part of the system.

Conformance to Standards

Before installing VersaMax products in situations where compliance to standards or directives from the Federal Communications Commission, the Canadian Department of Communications, or the European Union is required please refer to GE Fanuc’s Installation Requirements for Conformance to Standards, GFK-1179.

Thermal Considerations

The thermal performance specified for modules in this manual requires a clearance of 2 inches (5.1cm) above and below the modules and 1 inch (2.54cm) on each side of the modules as shown below, regardless of the orientation of the DIN rail.

When using a vertical DIN rail, the CPU or NIU module must be installed at the bottom. Individual modules have may additional clearance requirements as shown in appendix A.

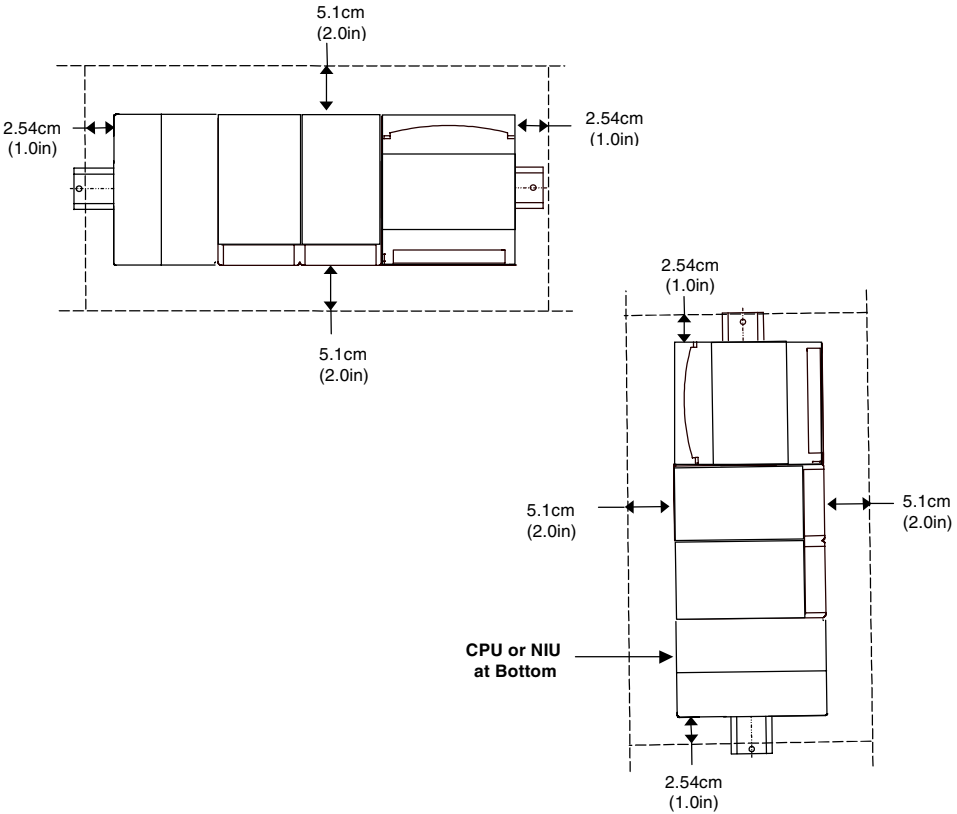

DIN Rail and Panel Mounting

Each rack in a VersaMax PLC or VersaMax I/O Station must be installed on a single section of 7.5mm X 35mm DIN rail, 1mm thick. Steel DIN rail is recommended. “Rack” is the term used for a CPU, NIU, or Expansion Receiver, plus up to 8 physically-connected I/O carriers. The first rack in a system is called Rack 0. If there are multiple expansion racks, Rack 0 also includes an Expansion Transmitter module installed in the leftmost position, before the CPU or NIU.

The DIN rail used in a VersaMax installation must be electrically grounded to provide EMC protection. The rail must have a conductive (unpainted) corrosion-resistant finish. DIN rails compliant with DIN EN50022 are preferred.

For vibration resistance, the DIN rail should be installed on a panel using screws spaced approximately 5.24cm (6 inches) apart. DIN-rail clamps (available as part number IC200ACC313) can also be installed at both ends of the station to lock the modules in position.

For applications requiring maximum resistance to mechanical vibration and shock, the DIN-rail-mounted carriers should also be mounted on the panel. Panel mount holes can be located on the panel by using the carrier as a template, or by following the dimensions shown in appendix A. Pre-drill the mounting holes and install the CPU, NIU, ERM , and carriers using M3.5 (#6) screws.

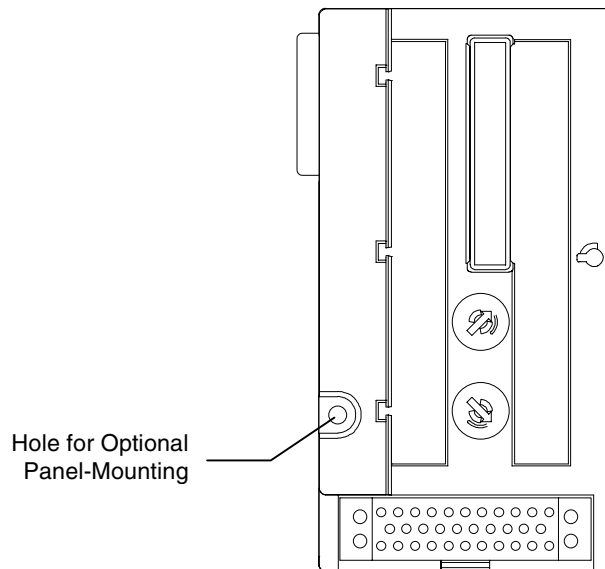

DIN Rail Installation Steps

VersaMax CPUs, Network Interface Unit (NIU) modules, Expansion Receiver (ERM) modules, and module carriers snap easily onto the DIN rail. No tools are required for mounting or grounding to the DIN rail.

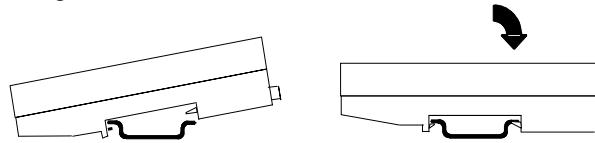

Before joining module carriers to a CPU, NIU, or ERM, remove the connector cover on the righthand side of the CPU, NIU, or ERM. Do not discard this cover; you will need to install it on the last carrier.

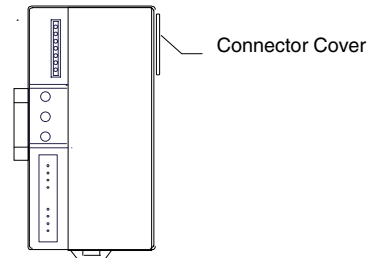

Slide carriers along the DIN rail to engage the connectors in the sides of adjacent carriers. To avoid damaging connector pins, do not force or slam carriers together.

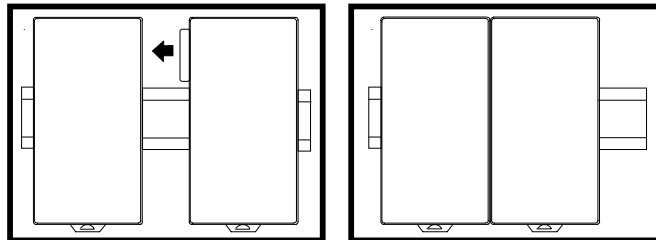

Install the connector cover that was removed over the connector on the last carrier to protect the connector pins and to provide compliance with standards.

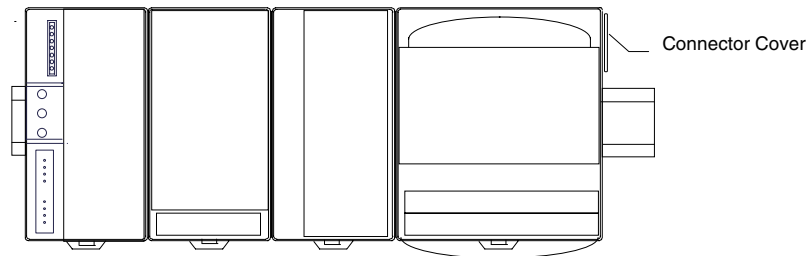

Installing an Expansion Transmitter Module

An Expansion Transmitter Module must be installed to the left of a CPU or NIU.

1. Make sure rack power is off.
2. Attach the Expansion Transmitter to DIN rail to the left of the CPU or NIU.
3. Slide the module toward the CPU or NIU and press together until the connectors are mated.
4. After completing any additional system installation steps, apply power and observe the module LEDs.

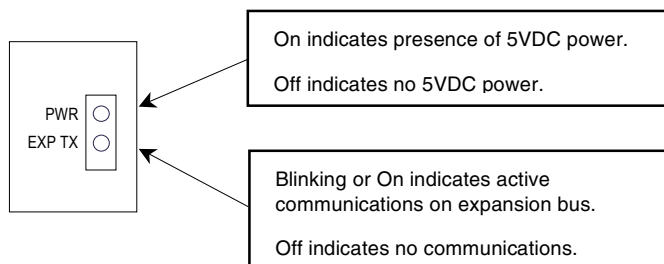

Removing an Expansion Transmitter Module

1. Make sure rack power is off.
2. Slide module on DIN rail away from the CPU or NIU in the main rack.
3. Using a small screwdriver, pull down on the tab on the bottom of the module and lift the module off the DIN rail.

Installing an Expansion Receiver Module

An Expansion Receiver Module (IC200ERM001 or 002) must be installed in the leftmost slot of each VersaMax expansion “rack”.

1. Insert the label inside the small access door at the upper left corner of the module.
2. Attach the module to the DIN rail at the left end of the expansion rack.
3. Select the expansion rack ID (1 to 7) using the rotary switch under the access door at upper left corner of the module. Each rack must be set to a different rack ID. With a single-ended cable (one expansion rack only), set the Rack ID to 1.

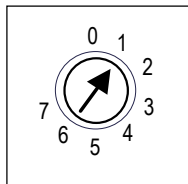

4. Install a VersaMax Power Supply module on top of the Expansion Receiver. See “Installing a Power Supply” in this chapter for details.
5. Attach the cables. If the system includes an Expansion Transmitter Module, attach the terminator plug to the EXP2 port on the last Expansion Receiver Module.
6. After completing any additional system installation steps, apply power and observe the module LEDs.

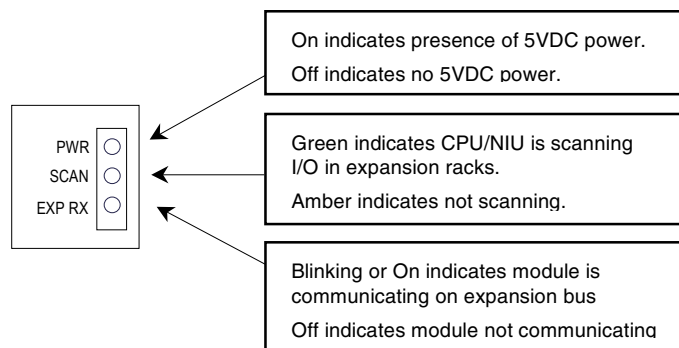

Removing an Expansion Receiver Module

1. Make sure rack power is off.
2. Un-install the Power Supply module from the Expansion Receiver Module.
3. Slide the Expansion Receiver Module on DIN rail away from the other modules.
4. Using a small screwdriver, pull down on the tab on the bottom of the module and lift the module off the DIN rail.

Connecting the Expansion Cable: RS-485 Differential

For a multiple-rack expansion system, connect the cable from the expansion port on the Expansion Transmitter to the Expansion Receivers as shown below. If all the Expansion Receivers are the Isolated type (IC200ERM001), the maximum overall cable length is 750 meters. If the expansion bus includes any non-isolated Expansion Receivers (IC200ERM002), the maximum overall cable length is 15 meters.

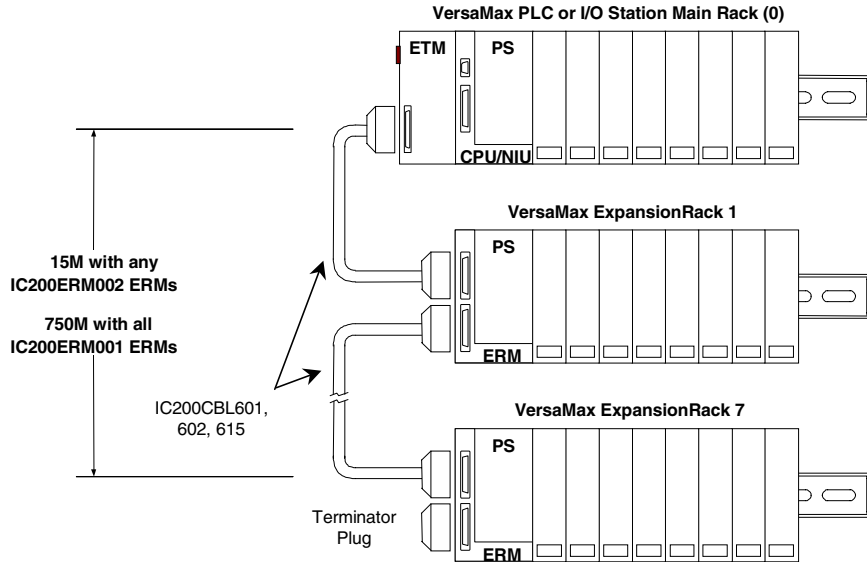

Install the Terminator Plug (supplied with the Expansion Transmitter module) into the lower port on the last Expansion Receiver. Spare Terminator Plugs can be purchased separately as part number IC200ACC201 (Qty 2).

RS-485 Differential Inter-Rack Connection (IC200CBL601, 602, 615)

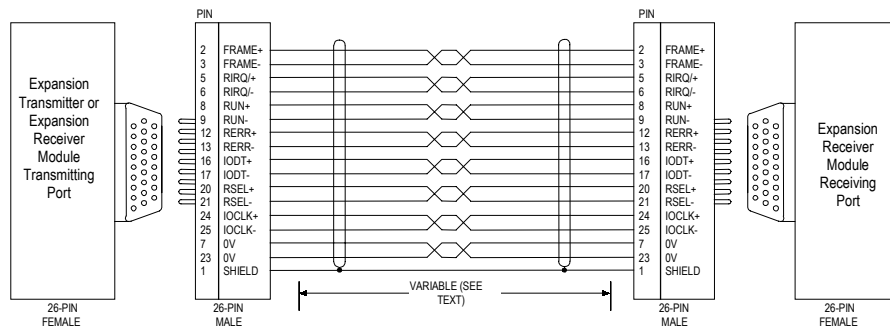

Building a Custom Expansion Cable

Custom expansion cables can be built using Connector Kit IC200ACC202, Crimper AMP 90800-1, and Belden 8138, Manhattan/CDT M2483, Alpha 3498C, or equivalent AWG #28 (0.089mm²) cable.

Connecting the Expansion Cable: Single-ended

For a two-rack local system with one non-isolated expansion rack (IC200ERM002) and NO Expansion Transmitter, connect the expansion cable from the serial port on the VersaMax CPU or NIU to the Expansion Receiver as shown below. The maximum cable length is one meter. Cables cannot be fabricated for this type of installation; cable IC200CBL600 must be ordered separately.

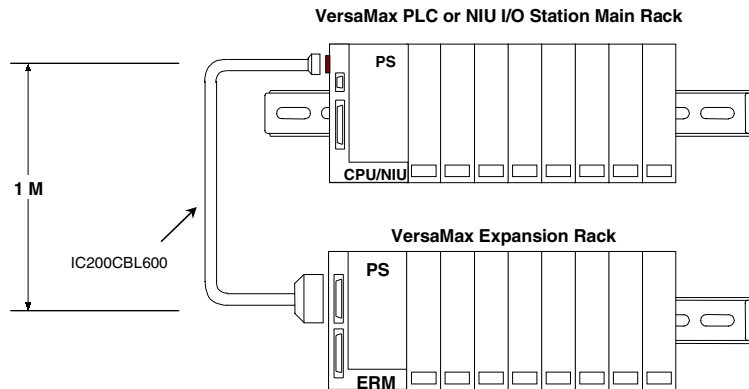

No Terminator Plug is needed in a single-ended installation; however, it will not impede system operation if installed.

Single-Ended Inter-Rack Connection Cable (IC200CBL600)

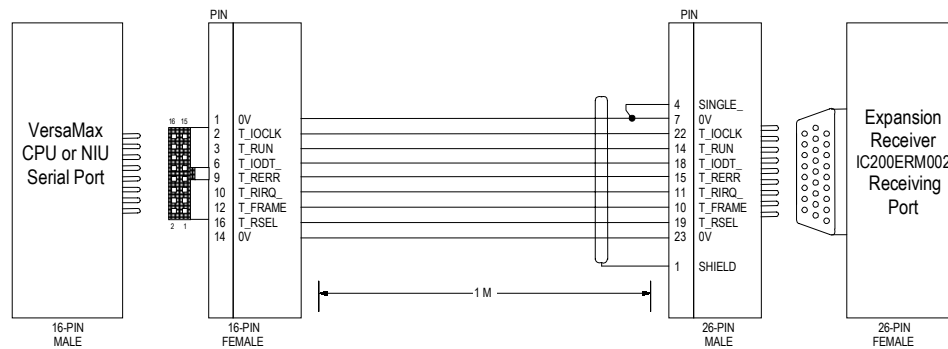

Installing a Power Supply

I/O and option modules receive power for their operation from the CPU, NIU, or Expansion Receiver Module via the mating connector on the carrier. The number of modules that can be supported depends on the power requirements of the modules (which are listed in the individual module specifications).

Power Supply Booster Carriers can be used as needed to meet the power needs of all modules. The AC or DC Power Supply on the CPU or NIU and the Power Supply that resides on the Booster Carrier must share the same external power source.

In some cases, the field devices served by an I/O module require additional AC or DC power, which must be provided using an “external” power supply. Specifications and connection details for such external power supplies are given in the module specifications in this manual.

Installing a Power Supply Module

The power supply module installs directly on top of a CPU, NIU, ERM, or booster carrier. The latch on the power supply must be in the unlocked position.

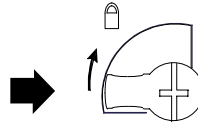

Align the connectors, tab, and latch post on the power supply to be parallel with the CPU, NIU, ERM, or carrier. Press the power supply module down firmly, until the two tabs on the bottom of the power supply click into place. Be sure the tabs are fully inserted in the holes in bottom edge of the CPU, NIU, ERM, or booster carrier.

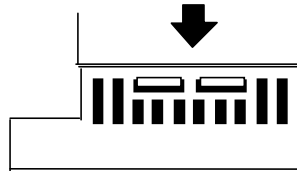

Turn the latch to the locked position to secure the power supply in place.

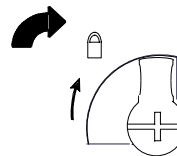

Note: The VersaMax power supply is not hot-swappable. Hot inserting or extracting the power supply is an improper method to power-down or power-up. Hot inserting the power supply can cause a “Corrupted User Memory Fault” condition. Power-cycling should only be accomplished by switching the main power going into the power-supply.

Removing a Power Supply

1. Switch off the external power source to the power supply module.
2. Turn the latch to the unlocked position.

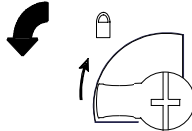

3. Press in the tabs on the lower edge of the power supply
4. Pull the power supply straight off.

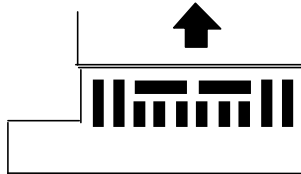

System Wiring Guidelines

Four types of wiring may be encountered in a typical factory installation:

- Power wiring – the plant power distribution, and high power loads such as high horsepower motors. These circuits may be rated from tens to thousands of KVA at 220 VAC or higher.
- Control wiring – usually either low voltage DC or 120 VAC of limited energy rating. Examples are wiring to start/stop switches, contactor coils, and machine limit switches. This is generally the interface level of discrete I/O.
- Analog wiring – transducer outputs and analog control voltages. This is the interface level to I/O analog blocks.
- Communications and signal wiring – the communications network that ties everything together, including computer LANs, MAP, and field busses.

These four types of wiring should be separated as much as possible to reduce the hazards from insulation failure, miswiring, and interaction (noise) between signals. A typical control system may require some mixing of the latter three types of wiring, particularly in cramped areas inside motor control centers and on control panels.

In general, it is acceptable to mix the communications bus cable with the I/O wiring from the blocks, as well as associated control level wiring. All noise pickup is cumulative, depending on both the spacing between wires, and the distance span they run together. I/O wires and communications bus cable can be placed randomly in a wiring trough for lengths of up to 50 feet. If wiring is cord-tied (harnessed), do not include the bus cable in the harness, since binding wires tightly together increases the coupling and mechanical stress that can damage the relatively soft insulation of some serial cable types. Consider using shielded cable in electrically noisy environments.

Wiring which is external to equipment, and in cable trays, should be separated following National Electrical Code practices.

Installing Power and Ground Wiring

Power Supply terminals accommodate one AWG #14 (avg. 2.1mm² cross section) to AWG #22 (avg. 0.36mm² cross section) wire, or two wires up to AWG #18 (avg. 0.86mm² cross section). Use copper wire rated for 90 degrees C. When inserting two wires in the same position, the wires must be the same size and the same type (solid or stranded).

Connect the ground terminal to the conductive mounting panel with a 4-inch maximum length of AWG #14 (avg. 2.1mm²) wire. Use hardware such as star washers to ensure ground integrity.

Grounding DC Power Supplies

DC power supplies are non-isolated. DC- must be grounded to frame / earth ground. DC+ is grounded to frame internally in the Power Supply. As a result, floating power supplies cannot be used.

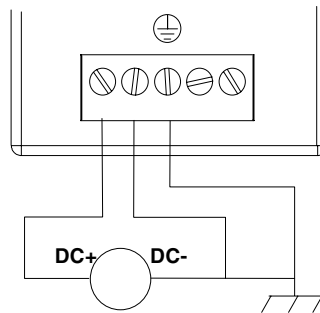

Grounding AC Power Supplies

AC power supplies are isolated. Therefore, the AC source does not have to be grounded. However, it is recommended to only use ground-referenced sources such as a neutral line or grounded center-tap transformer.

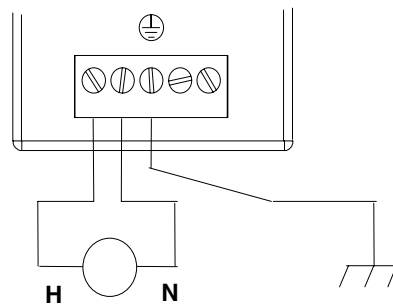

Jumper Installation on an AC Power Supply Module

AC power supply modules (IC200PRW101 and IC200PWR102) can be used with either 120VAC or 240VAC nominal input power. For 120VAC nominal operation, install a jumper as marked on the power supply. Use insulated AWG #14 (avg. 2.1mm² cross section) to AWG #22 (avg. 0.36mm² cross section) wire.

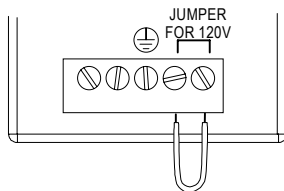

The power supply operates without a jumper installed; however, the hold-up specification is not met. If a jumper is not installed for 120VAC operation, the power supply will not cause hazardous conditions.

Warnings

DO NOT USE A JUMPER FOR 240VAC OPERATION. If a jumper is used on the input connector for 240VAC nominal operation, the power supply will be damaged and may cause hazardous conditions.

Do not touch the exposed portions of the jumper wire with power applied to the system. Hazardous voltages are present that could cause personal injury.

Installing Additional Suppression

For agency compliance, external MOV suppression is required from both the positive and negative input to frame ground or at the power line input of a system enclosure (see below). The axial-leaded ZA series of MOVs from Harris is often used. The 20mm size, model V36ZA80 rated at 160 joules is sufficient for both supply types. The MOV should be able to handle most line transients. Measurement of actual transients may be required in extreme cases to decide what MOV is best.

Installing Suppression at the Power Supply

Typical power and ground connections are shown below.

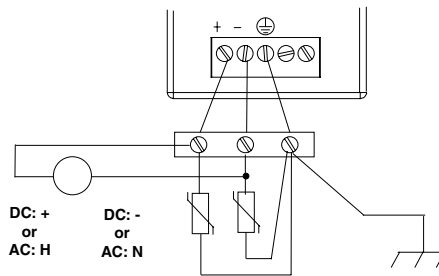

Installing Suppression for Devices in an Enclosure

For a group of devices installed in an enclosure, MOVs can be installed at the point where the power lines enter the enclosure. Ideally, MOVs should be used at each cabinet in the system for maximum protection. The following illustration shows suppression on both power lines and a communications bus entering an enclosure.

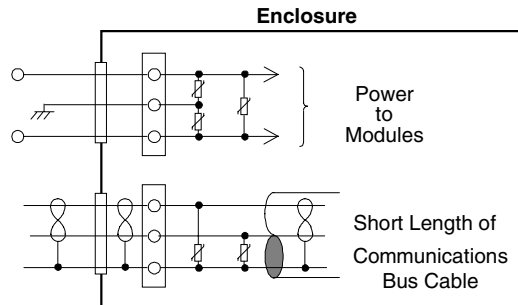

Periodic Inspection and Replacement of MOVs

MOVs do a good job of absorbing transients on communications, control, and power lines, provided the total energy of those transients does not exceed the rating of the device. However, if the energy of the transient exceeds the rating of the device, the MOV may be either damaged or destroyed. *This failure may not be visibly or electrically evident.* MOVs should be regularly inspected for signs of damage to assure continued protection against transients. For some applications, periodic replacement of critical MOVs is recommended, even if they do not show signs of damage.

System Grounding

All components of a control system and the devices it controls must be properly grounded. Ground conductors should be connected in a star fashion, with all branches routed to a central earth ground point as shown below. This ensures that no ground conductor carries current from any other branch.

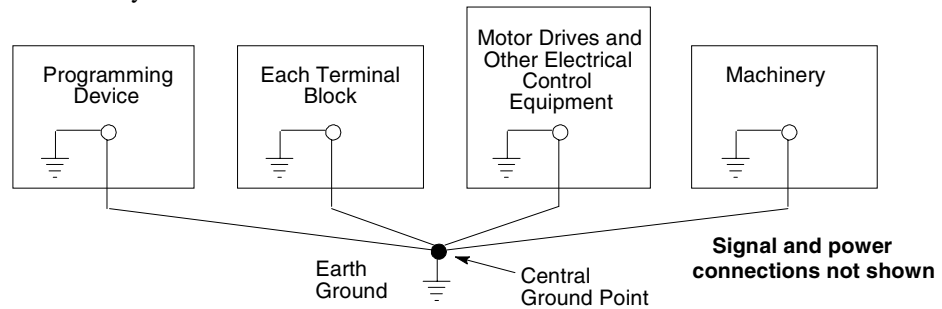

The control panel and enclosure should also be bonded to the plant system ground per code. Inadequate grounding may compromise system integrity in the presence of power switching transients and surges.

Installing Wiring for I/O Devices

Wiring to Inductive Loads

When wiring outputs to inductive loads, use of external suppression circuits is recommended. If possible, the external suppression circuits should be connected across the actual load. If that is not possible, external suppression circuits should be connected to each point that will drive an inductive load as shown below.

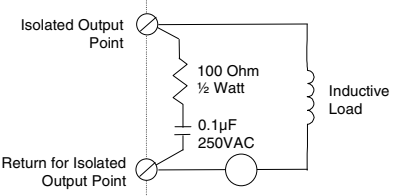
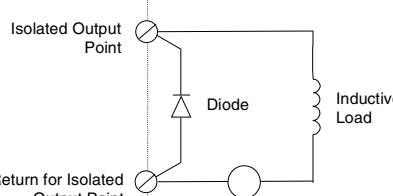
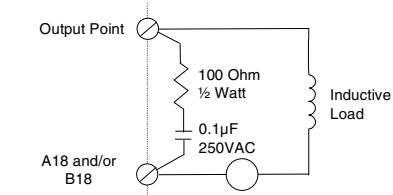
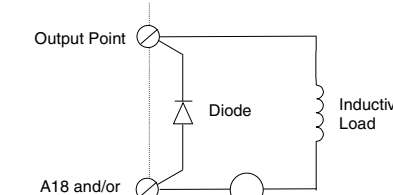
<p>AC Inductive Loads</p> <p>For AC inductive loads, the snubber network should consist of a 250VAC, 0.1μF capacitor connected in series with a 100 Ohm ½ Watt or higher resistor. A capacitor with a different working voltage may be chosen, as appropriate for the application.</p> <p>Recommended snubber packages include 104M06QC100 or 104M06RL100 from Paktron.</p>	<p>DC Inductive Loads</p> <p>For DC inductive loads, a diode should be placed across the load as shown below. Recommended diodes include:</p> <p>1N4934 100 volt, 1A; 1N4936 400 volt, 1A; 1N4937 600 volt, 1A.</p> <p>These diodes are available from most manufacturers.</p>
<p>Isolated Outputs, AC</p> 	<p>Isolated Outputs, DC</p> 
<p>Grouped Outputs, AC</p> 	<p>Grouped Outputs, DC</p> 

Wiring for a Compact I/O Carrier (IC200CHS022, IC200CHS025)

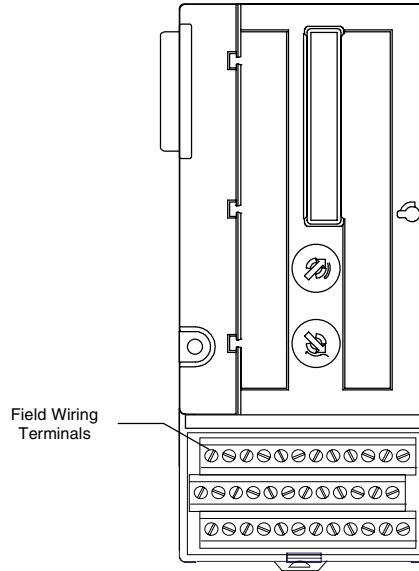

Each terminal on a Compact-style I/O Carrier accommodates one solid or stranded AWG #14 (avg. 2.1mm² cross section) to AWG #22 (avg. 0.36mm² cross section) wire, or two wires up to AWG #18 (avg. 0.86mm² cross section). Use copper wire rated for 90 degrees C. When inserting two wires in the same position, the wires must be the same size and type (solid or stranded).

The I/O carrier can accommodate current levels up to 2 Amps per point or 8 Amps per each power and ground, and a voltage range of up to 264 VAC. Voltage transients up to 300 VAC will not damage the carrier.

For a Box-Style I/O Carrier, recommended terminal torque is .37 to .45 ft-lbs.

The label provided with the module can be folded and inserted in the label holder.

Terminal Numbering for a Box- or Spring-Style Compact I/O Carrier

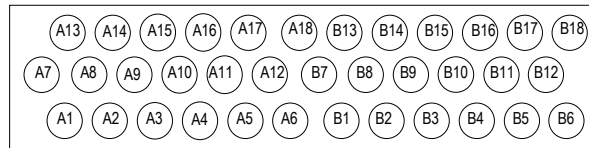

Wiring for a Box-Style I/O Carrier or Spring-Style I/O Carrier (IC200CHS002, IC200CHS005)

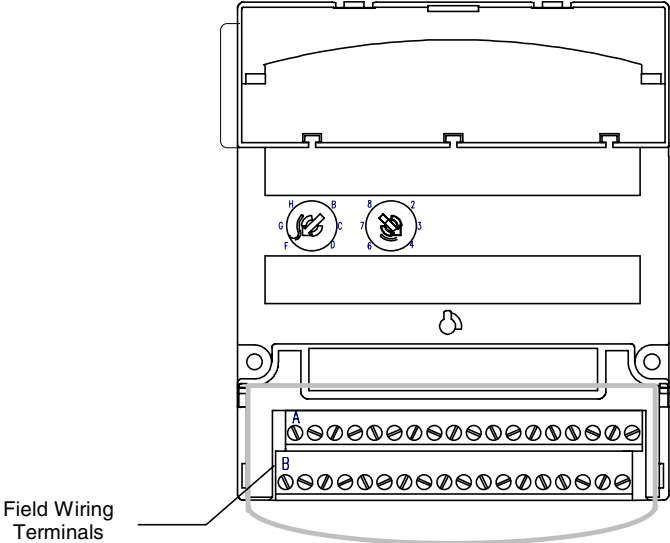

Each terminal on a Box-Style or Spring-Style I/O Carrier accommodates one solid or stranded AWG #14 (avg. 2.1mm² cross section) to AWG #22 (avg. 0.36mm² cross section) wire, or two wires up to AWG #18 (avg. 0.86mm² cross section). Use copper wire rated for 90 degrees C. When inserting two wires in the same position, the wires must be the same size and type (solid or stranded).

The I/O carrier can accommodate current levels up to 2 Amps per point or 8 Amps per each power and ground, and a voltage range of up to 264 VAC. Voltage transients up to 300 VAC will not damage the carrier.

For a Box-Style I/O Carrier, recommended terminal torque is .37 to .45 ft-lbs.

The label provided with the module can be folded and inserted in the module's transparent door.

Terminal Numbering for a Box-Style or Spring-Style I/O Carrier

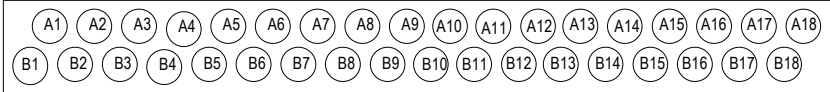

Wiring for a Barrier-Style I/O Carrier (IC200CHS001)

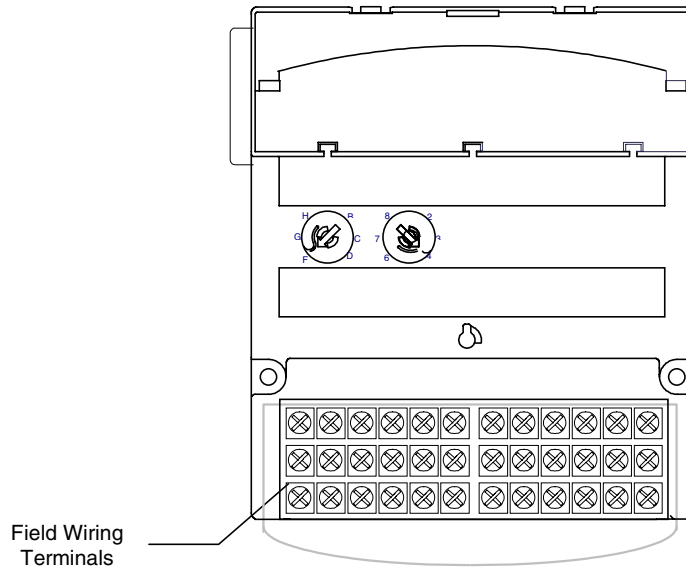

Each terminal on a Barrier-Style I/O Carrier accommodates one or two solid or stranded wires from AWG #22 (avg. 0.36mm² cross section) to AWG #14 (avg. 2.1mm² cross section). Use copper wire rated for 90 degrees C. When inserting two wires in the same position, the wires must be the same size and type (solid or stranded).

The I/O carrier can accommodate current levels up to 2 Amps per point or 8 Amps per each power and ground, and a voltage range of up to 264 VAC. Voltage transients up to 300 VAC will not damage the carrier.

For a Barrier-Style I/O Carrier, recommended terminal torque is .37 to .50 ft-lbs.

The label provided with the module can be folded and inserted in the module’s transparent door.

Terminal Numbering for a Barrier-Style I/O Carrier

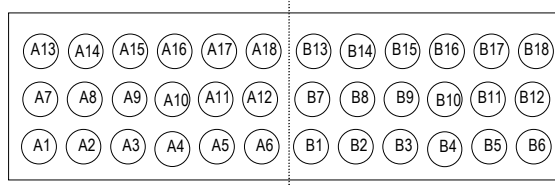

Wiring for a Connector-Style I/O Carrier (IC200CHS003)

For a Connector-Style I/O Carrier field connections are usually made to an Interposing I/O Terminal unit and one or more Auxiliary I/O Terminals. However, it is also possible to make field wiring connections directly to the Connector-Style I/O Carrier itself using contacts crimped to the ends of the field wires.

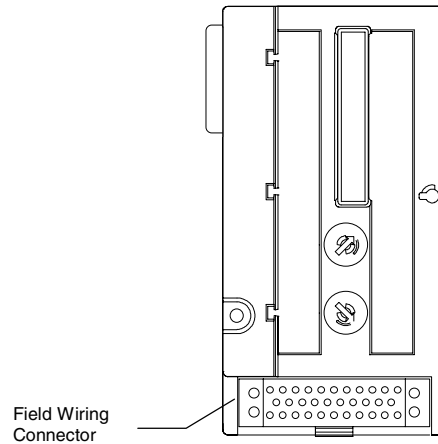

Prewired Cables for a Connector-Style I/O Carrier

Connection between a Connector-Style I/O Carrier and Interposing I/O Terminals is made by cable. The following cables are available:

IC200CBL105	2 connectors, 0.5m, no shield
IC200CBL110	2 connectors, 1.0m, no shield
IC200CBL120	2 connectors, 2.0m, no shield
IC200CBL230	1 connector, 3.0m, no shield

Installing and Removing a Prewired Cable

To install a prewired connecting cable, place the cable connector over the connector on the carrier and press downward until the latch engages the tab on the connector. (If you have an IC200CBLxxx cable with a non-molded style connector, please turn to appendix E for installation and removal instructions).

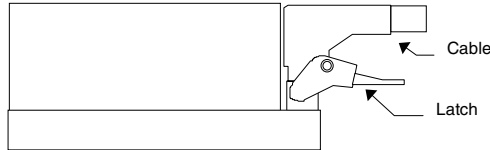

To remove the cable, hold the cable connector and press up on the latch to release the connector. When removing the cable, remember that operating equipment may be very hot, especially at higher ambient temperatures. If the equipment is hot, do not touch it directly. DO NOT TOUCH exposed connector pins if the system is operating.

Connector Kit

A connector kit (part number IC200ACC304) is available for building custom cables or for connecting wires directly from field devices. The kit includes a connector and cover, two screws, 36 small contacts, and 6 large contacts. The following equipment is also required but not included in the kit:

Crimping Tools	small contact	Molex 11-01-0008
	large contact	Molex 11-01-0084
Extraction Tools	small contact	Molex 11-03-0002
	large contact	Molex 11-03-0006

Terminal Numbering

The illustration below shows the terminal assignments of the connector pins as viewed from above.

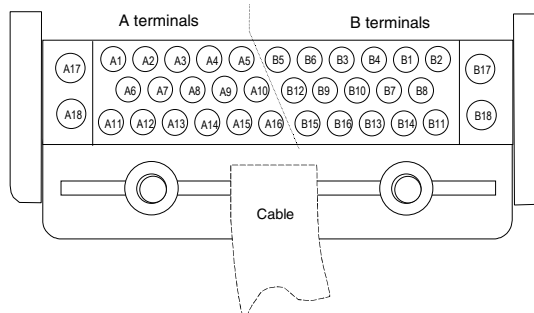

Terminal Assignments for Cable IC200CBL230

The tables that follow show terminal assignments for cable IC200CBL230. Cable IC200CBL230 is available in two cable types. They are functionally equivalent. The cable type is marked on the cable.

“Belden” Cable Terminal Assignments

Terminal Block Position	Base color	1 st spot	2 nd spot	terminal #	wire #
A1	Black			36	32
A2	Black	Red		35	34
A3	Black	White	Green	34	23
A4	Orange	Red		33	11
A5	Red	Green		32	36
A6	Blue	Red		25	16
A7	Black	White	Orange	24	22
A8	Green	White		23	38
A9	Red	Black	Green	22	10
A10	Blue	White		21	13
A11	Blue	White	Orange	15	37
A12	Orange	Black	Green	14	21
A13	Green	Black	Orange	13	9
A14	Blue	Black		12	12
A15	Black	Red	Green	11	30
A16	Blue	Black	White	10	24
A17	White	Red		4	7
A17	White	Black	Red	4	8
A18	White			3	5
A18	White	Red	Green	3	6
B1	Red	Black		27	35
B2	Red			26	33
B3	Red	White	Green	29	17
B4	Black	White	Red	28	18
B5	Orange	White	Blue	31	19
B6	Orange	Green		30	15
B7	Green			17	14
B8	Orange	Black		16	27
B9	Green	Black		19	29
B10	Orange			18	40
B11	Red	Black	White	5	31
B12	Red	White		20	39
B13	Orange	Black	White	7	26
B14	Green	Black	White	6	25
B15	Blue			9	28
B16	Black	White		8	20
B17	White	Black	Green	2	3
B17	White	Black		2	4
B18	White	Red	Blue	1	1
B18	White	Red	Orange	1	2

“Alpha” Cable Terminal Assignments

Terminal Block Position	Base color	1st stripe	2nd stripe	terminal #	wire #
A1	White	Brown	Blue	36	32
A2	White	Brown	Gray	35	34
A3	White	Black	Yellow	34	23
A4	White	Black		33	11
A5	White	Red	Yellow	32	36
A6	White	Green		25	16
A7	White	Black	Orange	24	22
A8	White	Red	Blue	23	38
A9	White			22	10
A10	White	Red		21	13
A11	White	Red	Green	15	37
A12	White	Black	Red	14	21
A13	Gray			13	9
A14	White	Brown		12	12
A15	White	Brown	Yellow	11	30
A16	White	Black	Green	10	24
A17	Blue			4	7
A17	Violet			4	8
A18	Yellow			3	5
A18	Green			3	6
B1	White	Red	Orange	27	35
B2	White	Brown	Violet	26	33
B3	White	Blue		29	17
B4	White	Violet		28	18
B5	White	Gray		31	19
B6	White	Yellow		30	15
B7	White	Orange		17	14
B8	White	Black	Gray	16	27
B9	White	Brown	Orange	19	29
B10	White	Red	Gray	18	40
B11	White	Brown	Green	5	31
B12	White	Red	Violet	20	39
B13	White	Black	Violet	7	26
B14	White	Black	Blue	6	25
B15	White	Brown	Red	9	28
B16	White	Black	Brown	8	20
B17	Red			2	3
B17	Orange			2	4
B18	Black			1	1
B18	Brown			1	2

Caution

Do not insert a test probe into the contacts. Permanent damage to the contacts will result.

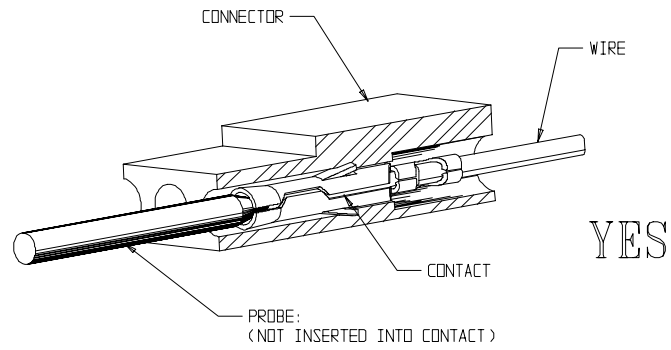
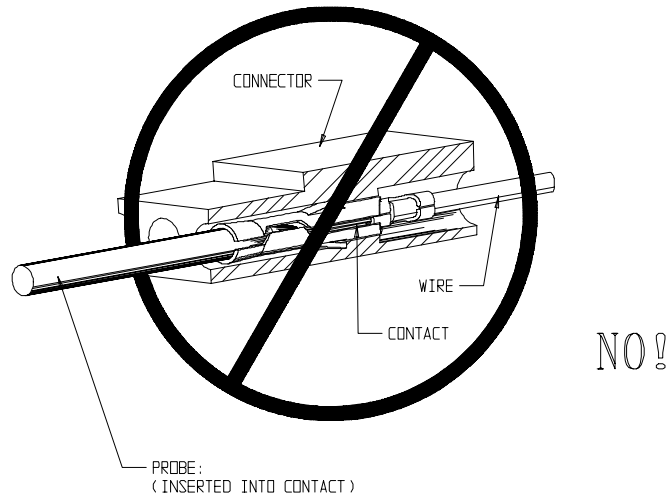

Installing Interposing I/O Terminals IC200TBM011, IC200TBM012, IC200TBM014, IC200TBM015

Interposing I/O Terminals are used to provide field-wiring connections to a Connector-style I/O Carrier (IC200CHS003). Installation and wiring for several styles of Interposing I/O Terminals is described in this section.

The Interposing I/O Terminals illustrated below are available with box-style terminals (IC200TBM002), spring-clamp style terminals (IC200TBM005), or barrier-style terminals (IC200TBM001). A version with box-style terminals and a built-in thermistor (IC200TBM014) is also available for use with Thermocouple modules, as described in chapter 14. A clear protective hinged door covers the wiring terminals. The printed wiring card provided with each I/O module can be folded and inserted in this door.

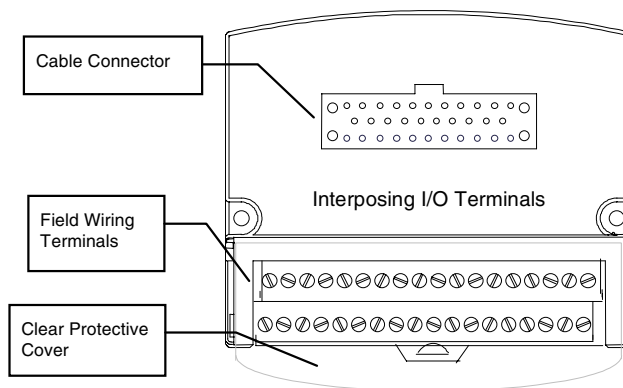

These Interposing I/O Terminals unit can be mounted on the same DIN rail as the Connector-Style I/O Carrier, or on a separate DIN rail. For applications requiring maximum resistance to mechanical vibration and shock, the Interposing I/O Terminals must also be panel-mounted.

Use copper wire rated for 90 degrees C. When inserting two wires in the same position, the wires must be the same size and type (solid or stranded). Wire specifications depend on the terminal type.

Wiring Specifications for IC200TBM012, IC200TBM014, and IC200TBM015

For box-type or spring type terminals, each terminal accommodates one solid or stranded AWG #14 (avg. 2.1mm² cross section) to AWG #22 (avg. 0.36mm² cross section) wire, or two wires up to AWG #18 (avg. 0.86mm² cross section).

Wiring Specifications for IC200TBM011

For barrier-type terminals, each terminal accommodates one or two solid or stranded wires from AWG #22 (avg. 0.36mm² cross section) to AWG #14 (avg. 2.1mm² cross section).

Installing Disconnect-Style Interposing I/O Terminals IC200CHS101, IC200CHS102

The Disconnect-Style Interposing I/O Terminals (IC200CHS101 and IC200CHS102) interface a VersaMax Connector-Style I/O Carrier to field wiring and provide an integrated disconnect option for field devices connected to VersaMax I/O modules. The Main Base, IC200CHS101, provides terminals that correspond to the "A" terminals on a VersaMax I/O module. If the I/O module also has "B" terminals, an Expansion Base, IC200CHS102) is also needed.

Field wiring to the interposing disconnect bases follows the standard wiring diagram for each module. Terminals A1-A18 and B1-B18 on the interposing disconnect terminal bases are connected in the same fashion as all other bases. The built-in auxiliary terminals (W1-W8, X1-X8, Y1-Y8, Z1-Z8) are positioned directly below the A or B terminals to provide for simple two-wire connection of field devices.

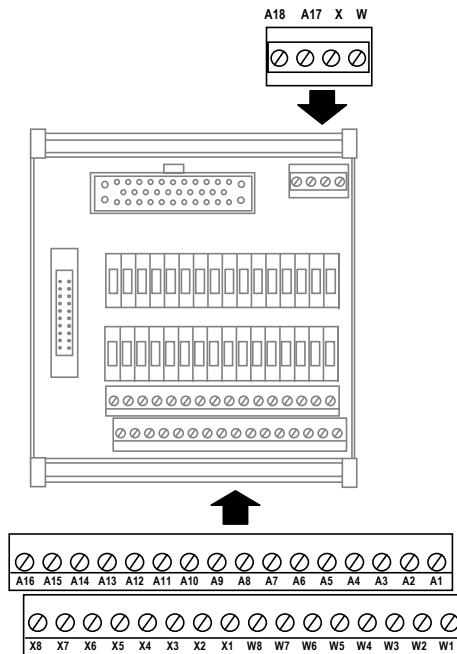

Each group of auxiliary terminals has a dedicated terminal to jumper the group to the appropriate VersaMax terminal (The "W" terminal is the connection point for W1-W8, etc.). The installation of these jumpers depends on the grouping present on the I/O module, as shown on the following pages.

Disconnect-Style Interposing I/O Bases, Terminal Wiring

Each terminal accommodates:

- one solid (0.2 to 4.0mm² cross section) or stranded (0.2 to 2.5mm² cross section), AWG #12 to AWG #24.

When inserting two wires in the same position, the wires must be the same size and type (solid or stranded):

- Rigid or flexible wires: 0.2 to 1.5mm² cross section.
- Stranded wires with ferrules, no plastic sleeve: 0.25 to 0.75mm² cross section
- Stranded wires with twin ferrule, with plastic sleeve:
 - upper level (A/B terminals): 0.5 to 1.5mm² cross section
 - lower level (W/X/Y/Z terminals): 0.5 mm² cross section.
- Recommended torque for the terminal screws is 0.5 to 0.6 Nm.

**Disconnect-Style Interposing I/O Terminals,
Wiring for Modules with One Group per Row**

This wiring format generally applies when the associated VersaMax module provides for connection of I/O in 16-point groups. An example of such a module is the VersaMax 24VDC 16pt Output Module, IC200MDL740:

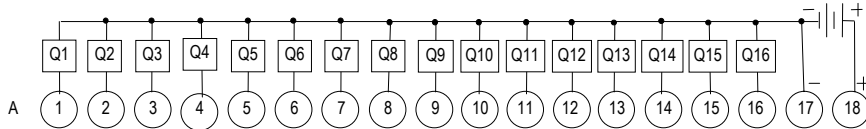

When connecting an Interposing Disconnect base in this format, follow these guidelines:

- Connect the field devices to A1-A16 (or B1-B16 where appropriate)
- Connect the return wires of field devices to the corresponding common connections – A1 to W1, A2 to W2, A9 to X1, A10 to X2, etc.
- Connect jumpers between the A17, W, and X terminals (or B17, Y, and Z)
- Connect the power supply between A17 and A18 (or B17 and B18)

Example: Wiring for Output Module IC200MDL740

Example field wiring for IC200CHS101 when used with VersaMax modules with 1 group per terminal row

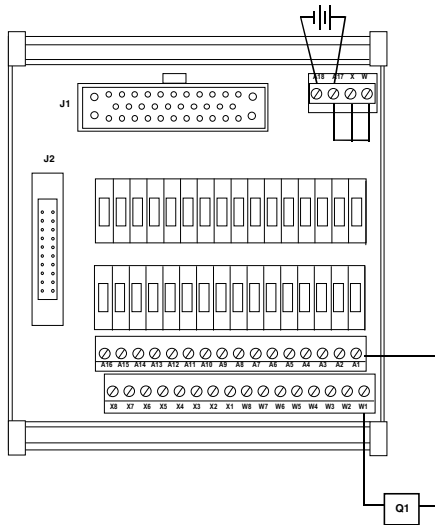

**Disconnect-Style Interposing I/O Terminals,
Wiring for Modules with Two Groups per Row**

This wiring format generally applies when the associated VersaMax module provides for connection of I/O in 8-point groups. An example of such a module is the VersaMax 24VDC 16pt Input Module, IC200MDL640:

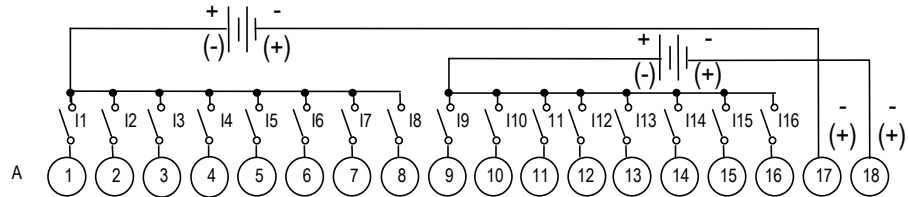

When connecting the Interposing Disconnect bases in this format, follow these guidelines:

- Connect field devices to A1-A16 (or B1-B16 where appropriate)
- Connect return wires of field devices to the corresponding common connections – A1 to W1, A2 to W2, A9 to X1, A10 to X2, etc.
- Connect jumpers between the A17, W, and X terminals (or B17, Y, and Z).
- Connect power supply between A17 and W (or B17 and Y).
- Connect power supply between A18 and X (or B18 and Z).

Example Wiring Diagram for Module IC200MDL640

Example field wiring for IC200CHS101 when used with VersaMax modules with 2 groups per terminal row

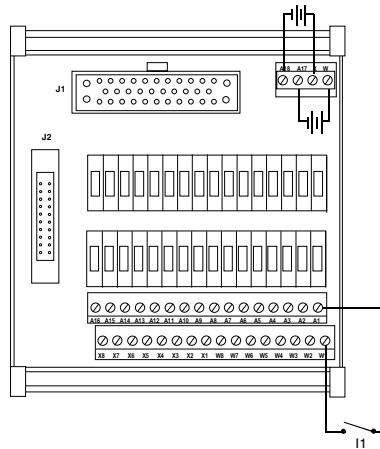

**Disconnect-Style Interposing I/O Terminals,
Wiring for Modules with Connections that are Not Grouped**

This wiring format generally applies when the associated VersaMax module provides for connection of isolated I/O devices, but may also be used when a non-isolated module provides dedicated terminals for each common connection. An example of an isolated module is the VersaMax 120VAC 8pt Isolated Input Module, IC200MDL143:

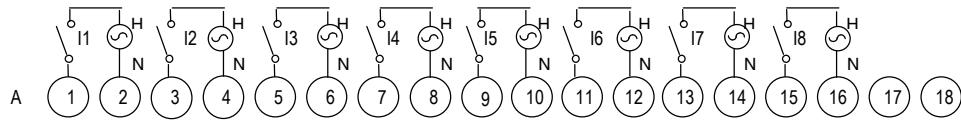

When connecting the Interposing Disconnect bases in this format, additional jumpers are usually not needed. Field wiring is connected to terminals A1-A16 (or B1-B16 where appropriate). The auxiliary terminals are not generally connected.

Example Wiring Diagram for Module IC200MDL143

Example field wiring for IC200CHS101 when used with VersaMax modules without grouped points.

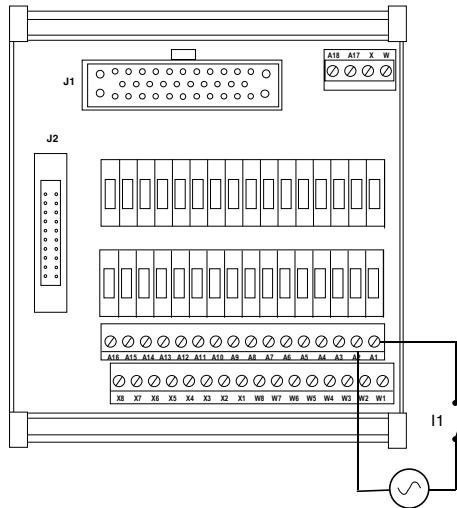

Installing Relay-Style Interposing I/O Terminals IC200CHS111 and IC200CHS112

The Relay-Style Interposing I/O Terminals (IC200CHS111 and IC200CHS112) each provide dry contacts capable of switching high current outputs (up to 8A) . For the Relay Style Interposing I/O Terminals, power for operation of the relay coils must be provided by an external 24VDC power supply. This power must be provided to both the main base (IC200CHS111) and the expansion base (IC200CHS112). Connection of this external power supply is made at the terminals A17 & A18 (B17 & B18 for the expansion base). This power connection is for the relay coils only. **User loads must be powered by an external source.**

Components labeled A1-A16 correspond to points Q1-Q16. Components labeled B1-B16 correspond to points Q17-Q32. Each point is associated with 3 terminal connections, labeled NO (Normally Open), C (Common), and NC (Normally Closed). Loads may be connected between C and NO, C and NC, or both.

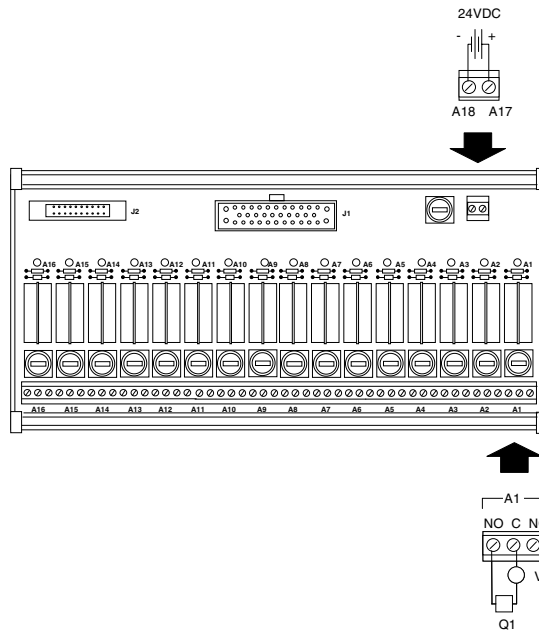

Relay-Style Interposing I/O Terminals, Terminal Wiring

Each terminal accommodates:

- One solid (0.2 to 4.0mm² cross section) or stranded (0.2 to 2.5mm² cross section), AWG #12 to AWG #24.

When inserting two wires in the same position, the wires must be the same size and type (solid or stranded), as specified below:

- Rigid or flexible wires: 0.2 to 1.5mm² cross section.
- Stranded wires with ferrules, no plastic sleeve: 0.25 to 0.75mm² cross section
- Stranded wires with twin ferrule, with plastic sleeve

Recommended torque for the terminal screws is 0.5 to 0.6 Nm.

Wiring for Auxiliary I/O Terminals

Auxiliary I/O Terminals can be used to provide extra field wiring connections if needed. They can be attached to either a terminal-style I/O carrier or to Interposing I/O Terminals. Auxiliary I/O Terminals units are available with 18 box-style terminals (as shown below) or with 18 spring style terminals or 12 barrier-style terminals.

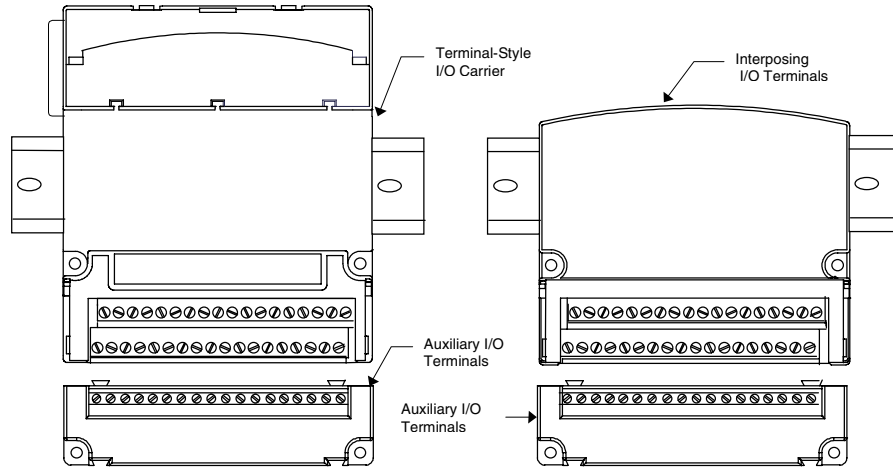

The terminals are electrically tied together. There is no electrical connection from the I/O Carrier or Interposing Terminals to the Auxiliary I/O Terminals; any necessary electrical reference must be provided. Multiple Auxiliary I/O Terminals can be connected together to provide the additional wiring terminals that may be needed for high-density modules, or for 2-, 3-, and 4-wire field devices.

Field Device	Diagram	16 Point Module		32 Point Module	
		Box-, Spring-, or Connector Carrier	Barrier-Style Carrier	Box-, Spring-, or Connector Carrier	Barrier-Style Carrier
1-wire		no Auxiliary Terminals			
2-wire		1 Auxiliary Terminals *	3 Auxiliary Terminals	2 Auxiliary Terminals *	3 Auxiliary Terminals
3-wire		2 Auxiliary Terminals *	6 Auxiliary Terminals	4 Auxiliary Terminals *	6 Auxiliary Terminals
4-wire		3 Auxiliary Terminals *	9 Auxiliary Terminals	6 Auxiliary Terminals *	9 Auxiliary Terminals

* for 16-point modules that only use one row of terminals for point wiring, a shorting bar may be used to provide extra terminals. See the heading **Using A Shorting Bar** in this chapter.

For example, a 16-point module might use 3 Auxiliary I/O Terminals for 4-wire devices:

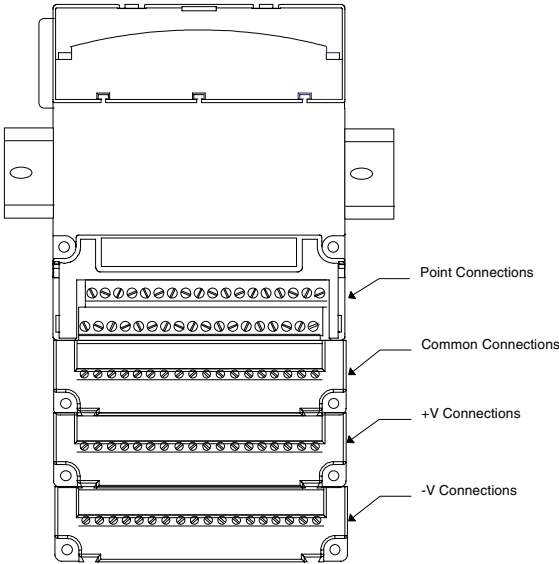

Auxiliary I/O Terminals accommodate current levels up to 8 Amps and voltage up to 264 VAC. Voltage transients up to 300 VAC will not cause damage.

Installing Auxiliary I/O Terminals

Auxiliary I/O Terminals are installed by inserting the tabs into the slots on the I/O Carrier or Interposing Terminals and pressing downward. Screws can be inserted through the panel-mount holes for added stability if needed.

Auxiliary Carriers must be installed on the I/O Carrier or Interposing Terminals before connecting field wiring.

Wire Specifications for Auxiliary I/O Terminals

Wire specifications depend on the terminal type. For box-type or spring type terminals, each terminal accommodates one solid or stranded AWG #14 (avg. 2.1mm² cross section) to AWG #22 (avg. 0.36mm² cross section) wire, or two wires up to AWG #18 (avg. 0.86mm² cross section).

For barrier-type terminals, each terminal accommodates one or two solid or stranded wires from AWG #22 (avg. 0.36mm² cross section) to AWG #14 (avg. 2.1mm² cross section).

Use copper wire rated for 90 degrees C. When inserting two wires in the same position, the wires must be the same size and type (solid or stranded).

Using Shorting Bars

Shorting Bars (part number IC200ACC303, quantity 2) can be a cost-effective solution for providing additional bussed terminals for modules that include only one I/O board. The shorting bar has a maximum current-carrying capacity of 2 Amps per point. See the individual module descriptions to determine whether a shorting bar can be used for a particular module.

The figures below show how a Shorting Bar can be used on a 2-row or 3-row carrier to provide extra field wiring connections for an I/O module.

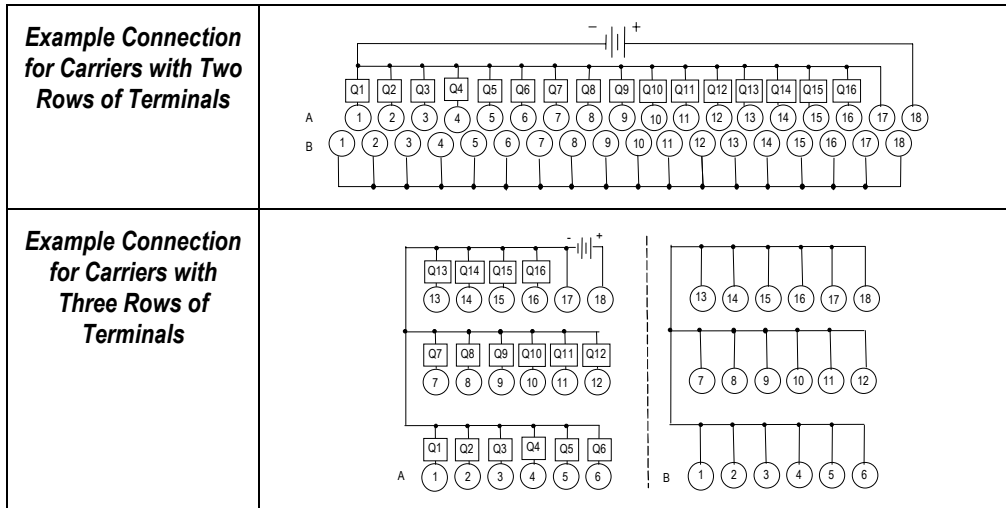

A Shorting Bar must be installed *directly on the carrier* before installing the I/O module.

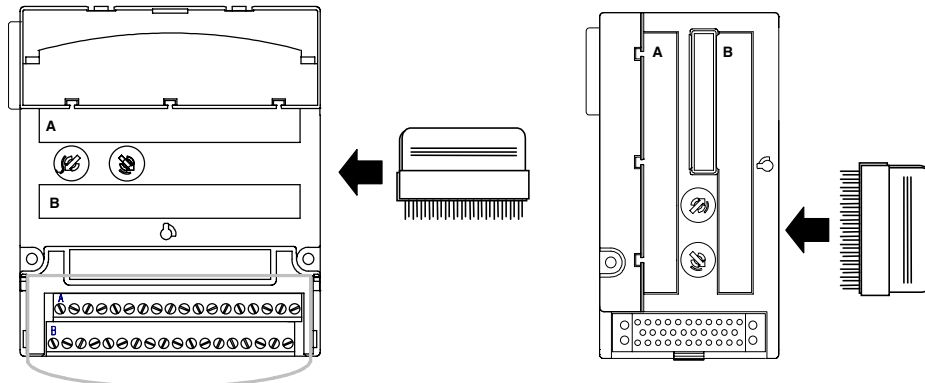

With a Shorting Bar in place, the unused terminals on the I/O Carrier or Interposing I/O Terminals unit can be used in the same way as the Auxiliary I/O Terminals described earlier.

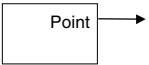
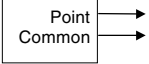
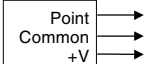
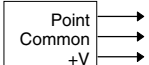
Field Device	Diagram	16 Point Module				32 Point Module	
		Box-, Spring-, or Connector Carrier	Barrier-Style Carrier	Box-, Spring-, or Connector Carrier with a Shorting Bar	Barrier-Style Carrier with a Shorting Bar	Box-, Spring-, or Connector Carrier	Barrier-Style Carrier
1-wire		no Auxiliary Terminals					
2-wire		1 Auxiliary Terminals	3 Auxiliary Terminals	no Auxiliary Terminals	Right side of barrier terminals on I/O Carrier	2 Auxiliary Terminals	3 Auxiliary Terminals
3-wire		2 Auxiliary Terminals	6 Auxiliary Terminals	1 Auxiliary Terminals	3 Auxiliary Terminals	4 Auxiliary Terminals	6 Auxiliary Terminals
4-wire		3 Auxiliary Terminals	9 Auxiliary Terminals	2 Auxiliary Terminals	6 Auxiliary Terminals	6 Auxiliary Terminals	9 Auxiliary Terminals

Installing Modules

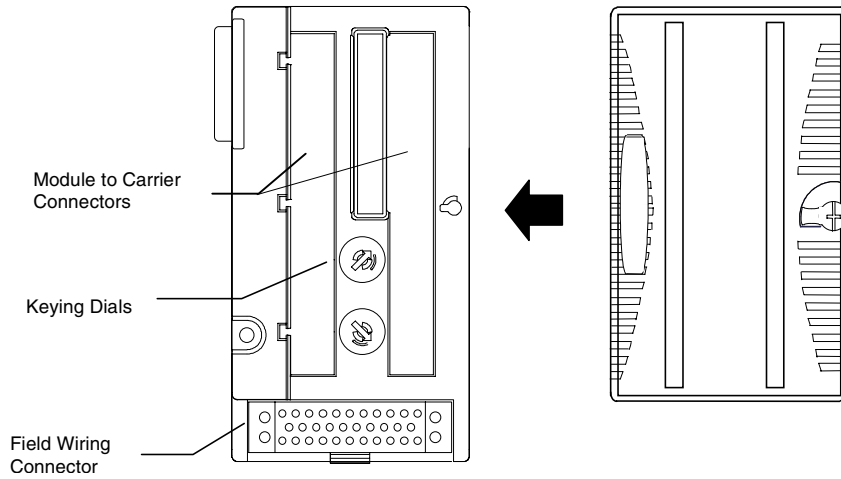

Setting the Carrier Keying

Keying dials on the carrier must be used to assure that the correct module type will be installed on that carrier. One dial selects alphabetic characters and the other selects numbers. These dials must be set to match the factory keying on the underside of the module. Module keying assignments are listed in appendix D.

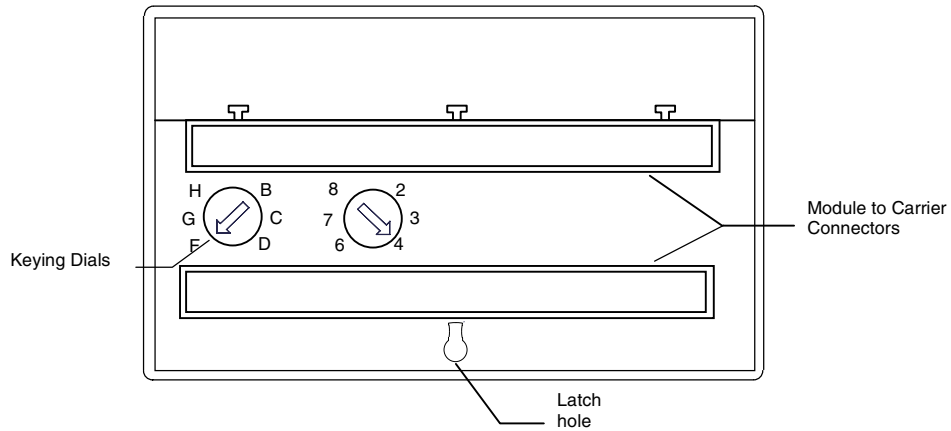

Installing a Module on a Carrier

Note: Before installing a module in an operating system, refer to the information below about Module Hot Insertion and Removal.

The latch on the module must be in the unlocked position as illustrated to install a module on its carrier.

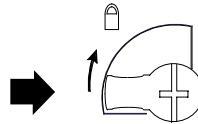

Align the three T-shaped projections on the module side with the slots on the carrier and align the latch post on the module with the hole on the carrier.

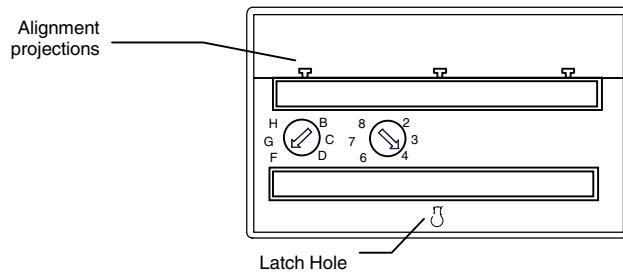

Press the module straight down onto the carrier, seating it fully.

Turn the latch to the locked position to secure the module to the top of the carrier.

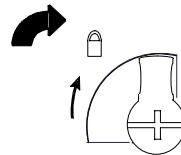

Hot Insertion and Removal of I/O Modules

If external power to an I/O module's field devices is removed, the module itself can be removed/inserted in an operating system (backplane power and CPU or NIU active) without affecting the rest of the system. Communications modules are not hot-insertable or removable.

For hot insertion, the I/O module must be properly seated on the carrier with all pins connected within 2 seconds. For removal, the module must be completely disengaged from the carrier within 2 seconds. If hot insertion or removal takes longer than 2 seconds, a System Misconfiguration fault may be generated, which may shut down the I/O Station.

CAUTION

Operating equipment may be very hot, especially at higher ambient temperatures. If the equipment is hot, do not touch it directly.

Such "hot insertion" and removal should not be attempted in hazardous locations. Personal injury, system malfunction and/or damage to the equipment may occur.

VersaMax equipment is suitable for use in non-hazardous locations or in Class 1, Div. 2, Groups A, B, C, and D, and Class 1 Zone 2 locations.

Explosion hazard: Substitution of components may impair suitability for Class 1, Division 2 and Class 1 Zone 2.

NOTE

The VersaMax power supply is not hot-swappable. Hot inserting or extracting the power supply is an improper method to power-down or power-up. Hot inserting the power supply can cause a "Corrupted User Memory Fault" condition. Power-cycling should only be accomplished by switching the main power going into the power-supply.

Chapter 3

Power Supplies

This chapter describes the VersaMax power supply modules. See chapter 4 for information about the Power Supply Booster Carrier, which can be used to install an additional “booster” power supply in the system.

- | | |
|---------------|---------------------------------------|
| ▪ IC200PWR001 | 24VDC Power Supply |
| ▪ IC200PWR002 | 24VDC Expanded 3.3V Power Supply |
| ▪ IC200PWR101 | 120/240VAC Power Supply |
| ▪ IC200PWR102 | 120/240VAC Expanded 3.3V Power Supply |
| ▪ IC200PWR201 | 12VDC Power Supply |
| ▪ IC200PWR202 | 12VDC Expanded 3.3V Power Supply |

IC200PWR001 24VDC Power Supply

24VDC Power Supply IC200PWR001 provides backplane power for CPU, NIU, and I/O modules. It supplies up to 1.5 Amps output current via 3.3 volt and 5 volt outputs, with up to 0.25 Amp on the 3.3 Volt output. This is ample power for most installations. Module backplane current consumption is summarized in appendix C.

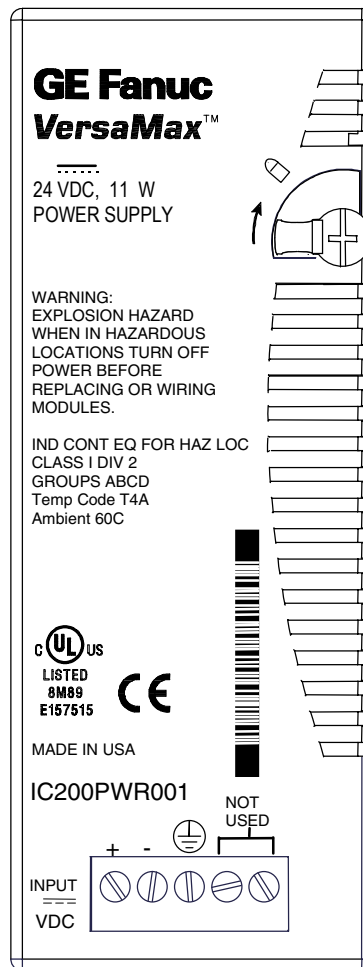

When mounted on the CPU or NIU module, it serves as the main power supply for the station. It can also be used as a supplemental power supply when mounted on a Power Supply Booster Carrier. Refer to the Power Supply Booster Carrier section of chapter 4 for more information.

IC200PWR001
24VDC Power Supply

Specifications

Input Voltage	18 to 30VDC, 24VDC nominal
Input Power	11W
Holdup Time	10ms
Inrush Current	20A at 24VDC 25A at 30 VDC
Output Voltage	5VDC, 3.3VDC
Protection	Short circuit, overload, reverse polarity
Output Current	
Total	1.5A maximum●
3.3VDC Output	0.25A maximum
5VDC Output	(1.5A - I _{3.3V}) maximum

- The total output current should not exceed 1.5A. For example, if 3.3V @ 0.25A is required, 1.25A is available on the 5V output.

Wiring

DC- must be grounded to frame / earth ground. DC- is grounded to frame internally in the Power Supply. As a result, floating power supplies cannot be used.

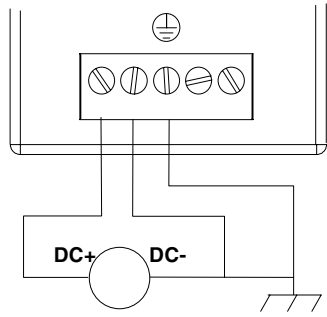

IC200PWR002 24VDC Expanded 3.3 V Power Supply

24VDC Expanded 3.3V Power Supply IC200PWR002 provides backplane power for CPU, NIU, and I/O modules. It supplies up to 1.5 Amps output current via 3.3 volt and 5 volt outputs, with up to 1.0 Amp on the 3.3 Volt output. Module backplane current consumption is summarized in appendix C.

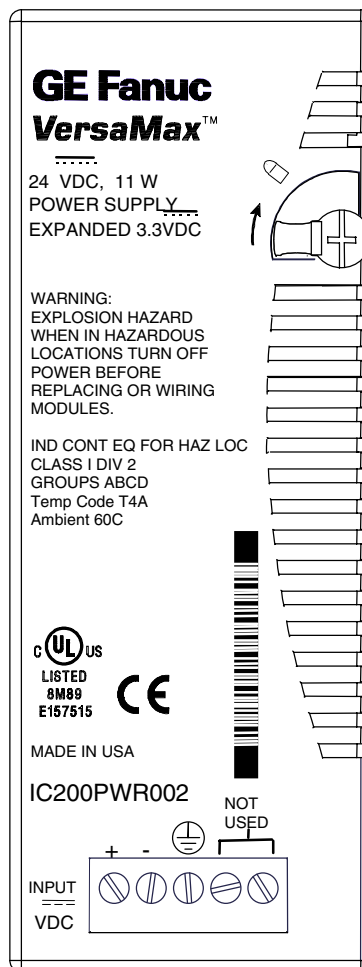

When mounted on the CPU or NIU module, it serves as the main power supply for the station. It can also be used as a supplemental power supply when mounted on a Power Supply Booster Carrier. Refer to the Power Supply Booster Carrier section of chapter 4 for more information.

IC200PWR002
24VDC Expanded 3.3 V Power Supply

Specifications

Input Voltage	18 to 30 VDC, 24VDC nominal
Input Power	11W
Holdup Time	10ms
Inrush Current	20A at 24VDC 25A at 30 VDC
Output Voltage	5VDC, 3.3VDC
Protection	Short circuit, overload, reverse polarity
Output Current Total 3.3VDC Output 5VDC Output	1.5A maximum● 1.0A maximum (1.5A - I _{3.3V}) maximum

- The total output current should not exceed 1.5A. For example, if 3.3V @ 1.0A is required, 0.5A is available on the 5V output.

Wiring

DC- must be grounded to frame / earth ground. DC- is grounded to frame internally in the Power Supply. As a result, floating power supplies cannot be used.

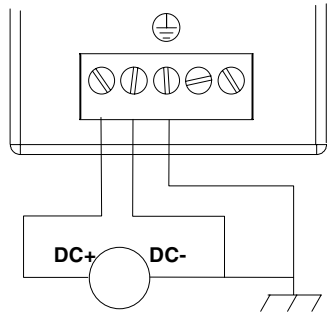

IC200PWR101 120/240VAC Power Supply

120/240VAC Power Supply IC200PWR101 provides backplane power for CPU, NIU, and I/O modules. It supplies up to 1.5 Amps output current via 3.3 Volt and 5 Volt outputs, with up to 0.25 Amp on the 3.3 volt output. This is ample power for most installations. Module backplane current consumption is summarized in appendix C.

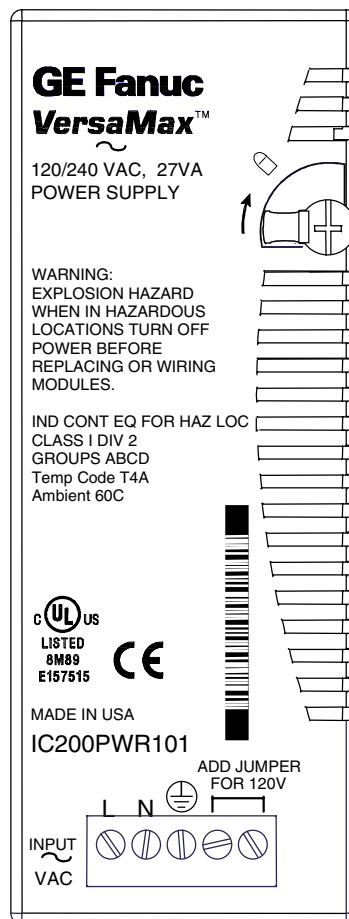

When mounted on the CPU or NIU module, this power supply serves as the main power supply for the station. It can also be used as a supplemental power supply when mounted on a Power Supply Booster Carrier. Refer to the Power Supply Booster Carrier section of chapter 4 for more information.

IC200PWR101
120/240VAC Power Supply

Specifications

Input Voltage	85 to 132 VAC with jumper installed, 120VAC nominal 176 to 264 VAC w/o jumper installed, 240VAC nominal
Input Power	27VA
Frequency	47 to 63Hz
Holdup Time	20ms
Output Voltage	5VDC, 3.3 VDC
Protection	Short circuit, overload
Output Current Total 3.3VDC Output 5VDC Output	1.5A maximum● 0.25A maximum (1.5A - I _{3.3V}) maximum

- The total output current should not exceed 1.5A. For example, if 3.3V @ 0.25A is required, 1.25A is available on the 5V output.

Jumper Selection of 120VAC or 240VAC

This power supply can be used with either 120VAC or 240VAC nominal input power. For 120VAC nominal operation, a jumper should be installed as marked on the power supply.

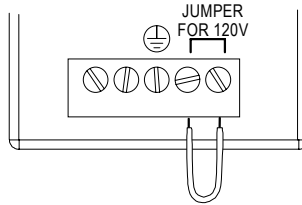

The power supply operates without a jumper installed; however, the hold-up specification is not met. If a jumper is not installed for 120VAC operation, the power supply will not cause hazardous conditions.

WARNING:

DO NOT USE A JUMPER FOR 240VAC OPERATION. If a jumper is used on the input connector for 240VAC nominal operation, the power supply will be damaged and may cause hazardous conditions.

IC200PWR102 120/240VAC Expanded 3.3V Power Supply

120/240VAC Expanded 3.3 Power Supply IC200PWR102 provides backplane power for CPU, NIU, and I/O modules. It supplies up to 1.5 Amps output current via 3.3 Volt and 5 Volt outputs, with up to 1.0 Amp on the 3.3V output. Module backplane current consumption is summarized in appendix C.

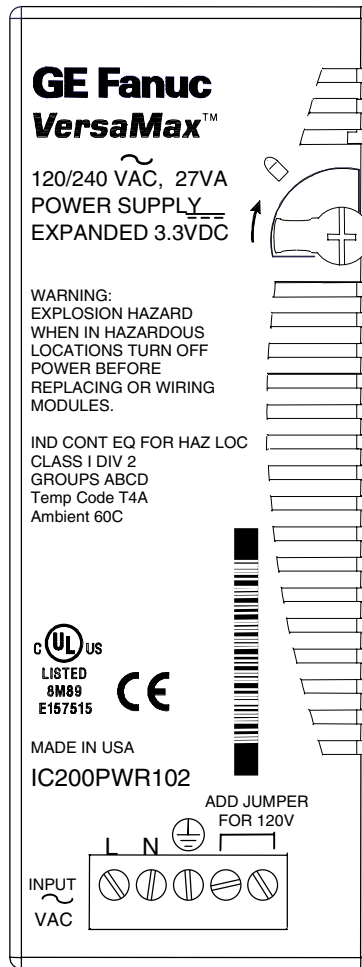

When mounted on the CPU or NIU module, this power supply serves as the main power supply for the station. It can also be used as a supplemental power supply when mounted on a Power Supply Booster Carrier. Refer to the Power Supply Booster Carrier section of chapter 4 for more information.

IC200PWR102
120/240VAC Expanded 3.3V Power Supply

Specifications

Input Voltage	85 to 132 VAC with jumper installed, 120VAC nominal 176 to 264 VAC w/o jumper installed, 240VAC nominal
Input Power	27VA
Frequency	47 to 63Hz
Holdup Time	20ms
Output Voltage	5VDC, 3.3 VDC
Protection	Short circuit, overload
Output Current	
Total	1.5A maximum●
3.3VDC Output	1.0A maximum
5VDC Output	(1.5A - I _{3.3V}) maximum

- The total output current should not exceed 1.5 A. For example, if 3.3V @ 1.0 A is required, 0.5 A is available on the 5V output.

Jumper Selection of 120VAC or 240VAC

This power supply can be used with either 120VAC or 240VAC nominal input power. For 120VAC nominal operation, a jumper should be installed as marked on the power supply.

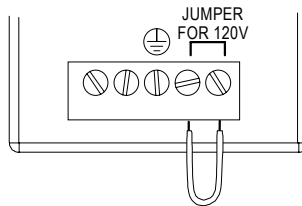

The power supply operates without a jumper installed; however, the hold-up specification is not met. If a jumper is not installed for 120VAC operation, the power supply will not cause hazardous conditions.

WARNING:

DO NOT USE A JUMPER FOR 240VAC OPERATION. If a jumper is used on the input connector for 240VAC nominal operation, the power supply will be damaged and may cause hazardous conditions.

IC200PWR201 12VDC Power Supply

12VDC Power Supply IC200PWR201 provides backplane power for CPU, NIU, and I/O modules. It supplies up to 1.5 Amps output current via 3.3 volt and 5 volt outputs, with up to 0.25 Amp on the 3.3 Volt output. This is ample power for most installations. Module backplane current consumption is summarized in appendix C.

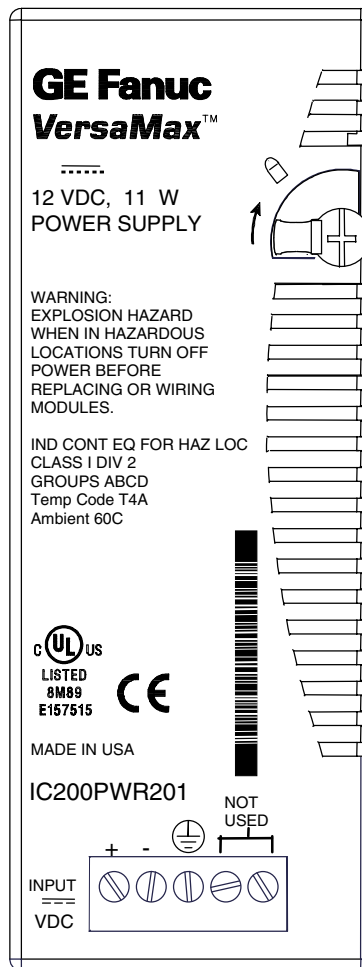

When mounted on the CPU or NIU module, it serves as the main power supply for the station. It can also be used as a supplemental power supply when mounted on a Power Supply Booster Carrier. Refer to the Power Supply Booster Carrier section of chapter 4 for more information.

**IC200PWR201
12VDC Power Supply**

Specifications

Input Voltage	9.6 to 15VDC, 12VDC nominal
Input Power	11W
Holdup Time	10ms
Inrush Current	25A at 12VDC 30A at 15VDC
Output Voltage	5VDC, 3.3VDC
Protection	Short circuit, overload, reverse polarity
Output Current	
Total	1.5A maximum●
3.3VDC Output	0.25A maximum
5VDC Output	(1.5A - I _{3.3V}) maximum

- The total output current should not exceed 1.5A. For example, if 3.3V @ 0.25A is required, 1.25A is available on the 5V output.

Wiring

DC- must be grounded to frame / earth ground. DC- is grounded to frame internally in the Power Supply. As a result, floating power supplies cannot be used.

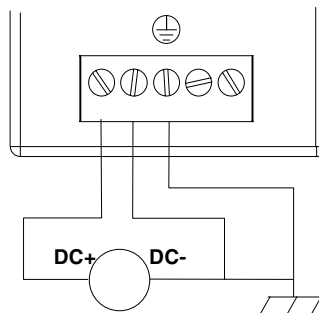

IC200PWR202 12VDC Expanded 3.3 V Power Supply

12VDC Expanded 3.3V Power Supply IC200PWR202 provides backplane power for CPU, NIU, and I/O modules. It supplies up to 1.5 Amps output current via 3.3 volt and 5 volt outputs, with up to 1.0 Amp on the 3.3 Volt output. Module backplane current consumption is summarized in appendix C.

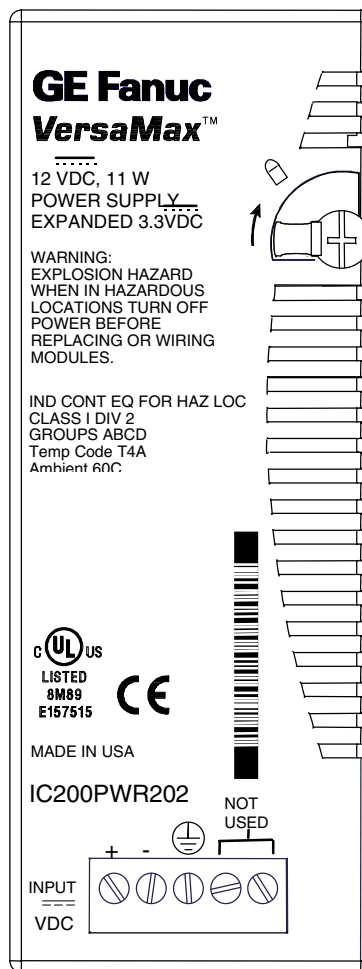

When mounted on the CPU or NIU module, it serves as the main power supply for the station. It can also be used as a supplemental power supply when mounted on a Power Supply Booster Carrier. Refer to the Power Supply Booster Carrier section of chapter 4 for more information.

IC200PWR202
12VDC Expanded 3.3 V Power Supply

Specifications

Input Voltage	9.6 to 15VDC, 12VDC nominal
Input Power	11W
Holdup Time	10ms
Inrush Current	25A at 12VDC 30A at 15VDC
Output Voltage	5VDC, 3.3VDC
Protection	Short circuit, overload, reverse polarity
Output Current Total 3.3VDC Output 5VDC Output	1.5A maximum● 1.0A maximum (1.5A - I _{3.3V}) maximum

The total output current should not exceed 1.5A. For example, if 3.3V @ 1.0A is required, 0.5A is available on the 5V output.

Wiring

DC- must be grounded to frame / earth ground. DC- is grounded to frame internally in the Power Supply. As a result, floating power supplies cannot be used.

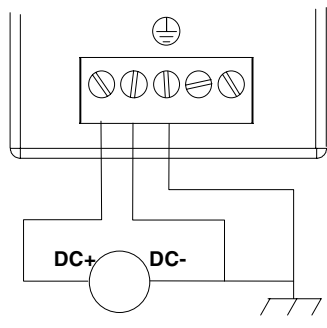

This chapter describes the Carriers that provide mounting and backplane communications for VersaMax modules.

- IC200CHS001 Barrier-Style I/O Carrier
- IC200CHS002 Box-Style I/O Carrier
- IC200CHS003 Connector-Style I/O Carrier
- IC200CHS005 Spring-Style I/O Carrier
- IC200CHS022 Compact Box-Style I/O Carrier
- IC200CHS025 Compact Spring-Style I/O Carrier
- IC200CHS006 Communications Carrier
- IC200PWB001 Power Supply Booster Carrier

**IC200CHS001
Barrier-Style I/O Carrier**

The Barrier-Style I/O Carrier (IC200CHS001) has 36 barrier-style terminals. It provides mounting, backplane communications, and field wiring for one I/O module.

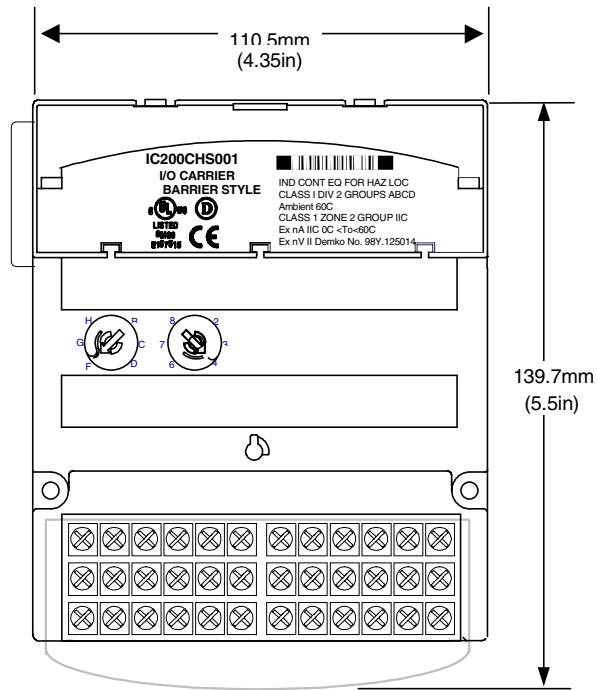

The I/O module mounts lengthwise (parallel to the DIN rail) on this carrier.

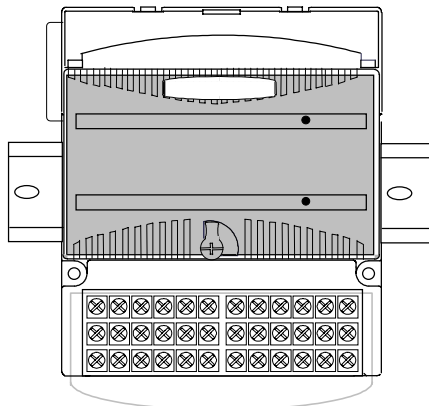

**IC200CHS001
Barrier-Style I/O Carrier**

Din Rail Mounting

The I/O carrier snaps easily onto a 7.5mm X 35mm DIN rail. The DIN rail must be electrically grounded to provide EMC protection. The rail must have a conductive (unpainted) corrosion-resistant finish.

For applications requiring maximum resistance to mechanical vibration and shock, the carrier must also be panel-mounted. See chapter 2 for installation instructions.

Features

- The Barrier-Style I/O carrier supports wiring for up to 32 I/O points and 4 common/power connections.
- Easily-set keying dials to assure installation of the correct type of module on the carrier. Keys are set to match the keying on the bottom of the module. A complete list of module keying assignments is included in appendix D.
- Carrier-to-carrier mating connectors for quick installation of the backplane connection with no additional cables or tools needed.
- Module latch hole for securely fastening the module to the carrier.
- A clear protective hinged door covering the wiring terminals. The printed wiring card provided with each I/O module can be folded and inserted in this door.
- Notches on the lower edge for attaching an Auxiliary I/O Terminal Strip if extra bussed connection points are needed.

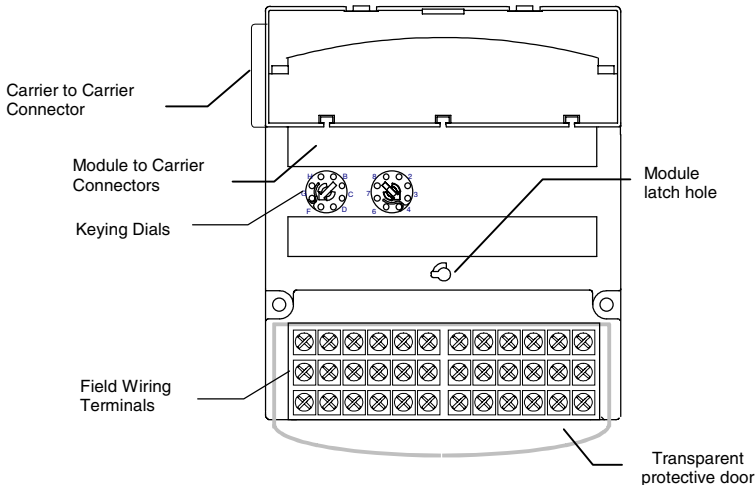

**IC200CHS001
Barrier-Style I/O Carrier**

Field Wiring Terminals

Each terminal accommodates one or two solid or stranded wires from AWG #22 (avg. 0.36mm² cross section) to AWG #14 (avg. 2.1mm² cross section).

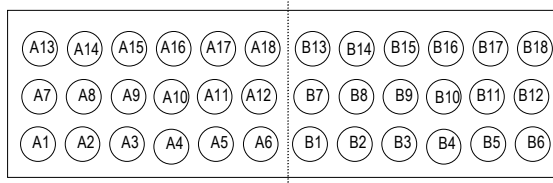

The carrier accommodates current levels up to 2 Amps per point or 8 Amps per each power and ground, and a voltage range of up to 264 VAC. Voltage transients up to 300 VAC will not damage the carrier.

One or more Auxiliary I/O Terminal Strips can be added to provide extra field wiring connections if needed. Auxiliary I/O Terminal Strips insert directly into the lower edge of the I/O Carrier.

**IC200CHS002
Box-Style I/O Carrier**

The Box-Style I/O Carrier (IC200CHS002) has 36 IEC box-style terminals. It provides mounting, backplane communications, and field wiring for one I/O module.

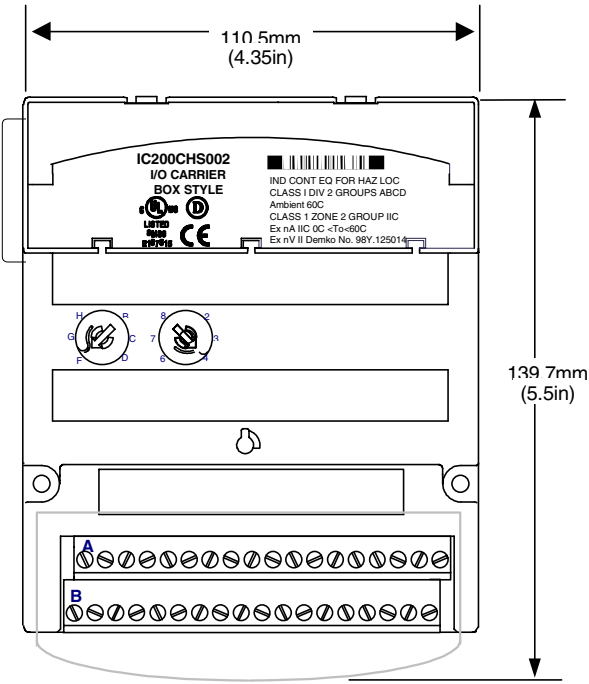

The I/O module mounts lengthwise (parallel to the DIN rail) on this carrier.

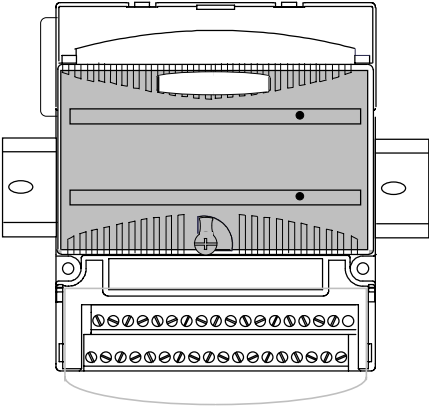

IC200CHS002 Box-Style I/O Carrier

Din Rail Mounting

The I/O carrier snaps easily onto a 7.5mm X 35mm DIN rail. The DIN rail must be electrically grounded to provide EMC protection. The rail must have a conductive (unpainted) corrosion-resistant finish.

For applications requiring maximum resistance to mechanical vibration and shock, the carrier must also be panel-mounted. See chapter 2 for installation instructions.

Features

- The Box-Style I/O carrier supports wiring for up to 32 I/O points and 4 common/power connections.
- Easily-set keying dials to assure installation of the correct type of module on the carrier. Keys are set to match the keying on the bottom of the module.
- Carrier-to-carrier mating connectors for quick installation of the backplane connection with no additional cables or tools needed.
- Module latch hole for securely fastening the module to the carrier.
- A clear protective hinged door covering the wiring terminals. The printed wiring card provided with each I/O module can be folded and inserted in this door.
- Notches on the lower edge for attaching an Auxiliary I/O Terminal Strip if extra bussed connection points are needed.

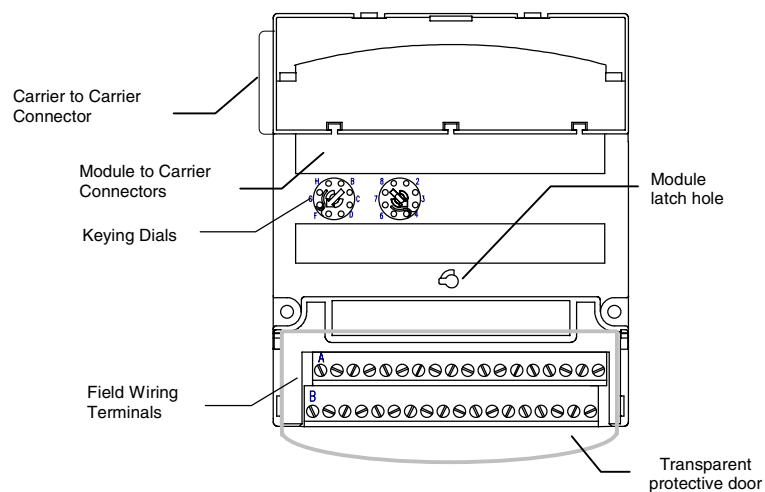

**IC200CHS002
Box-Style I/O Carrier**

Field Wiring Terminals

Each terminal accommodates one solid or stranded AWG #14 (avg. 2.1mm² cross section) to AWG #22 (avg. 0.36mm² cross section) wire, or two wires up to AWG #18 (avg. 0.86mm² cross section).

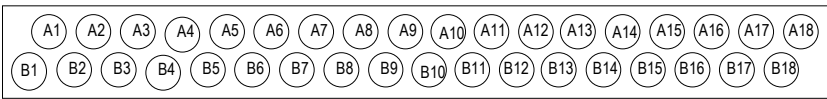

The carrier accommodates current levels up to 2 Amps per point or 8 Amps per each power and ground, and a voltage range of up to 264 VAC. Voltage transients up to 300 VAC will not damage the carrier.

One or more Auxiliary I/O Terminal Strips can be added to provide extra field wiring connections if needed. Auxiliary I/O Terminal Strips insert directly into the lower edge of the I/O Carrier.

IC200CHS003
Connector-Style I/O Carrier

The Connector-Style I/O Carrier (IC200CHS003) has a 36-pin connector for attaching an I/O cable. It provides mounting, backplane communications, and field wiring for one I/O module.

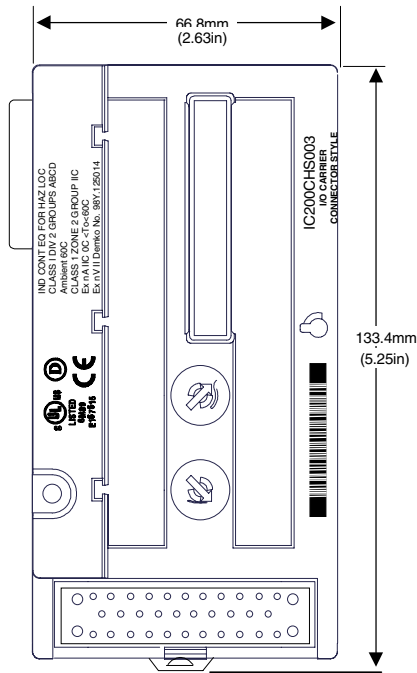

The I/O module mounts vertically (perpendicular to the DIN rail) on this carrier.

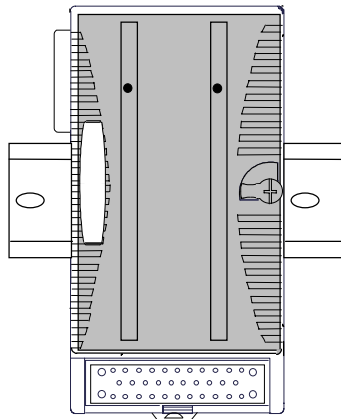

**IC200CHS003
Connector-Style I/O Carrier**

Din Rail Mounting

The carrier snaps easily onto a 7.5mm X 35mm DIN rail. The DIN rail must be electrically grounded to provide EMC protection. The rail must have a conductive (unpainted) corrosion-resistant finish.

For applications requiring maximum resistance to mechanical vibration and shock, the carrier must also be panel-mounted. See chapter 2 for installation instructions.

Features

- Easily-set keying dials to assure installation of the correct type of module on the carrier. Keys are set to match the keying on the bottom of the module. A complete list of module keying assignments is included in appendix D.
- Carrier-to-carrier mating connectors for quick installation of the backplane connection with no additional cables or tools needed.
- Module latch hole for securely fastening the module to the carrier.
- Connector provides quick attachment of wiring for up to 32 I/O points and 4 common/power connections.

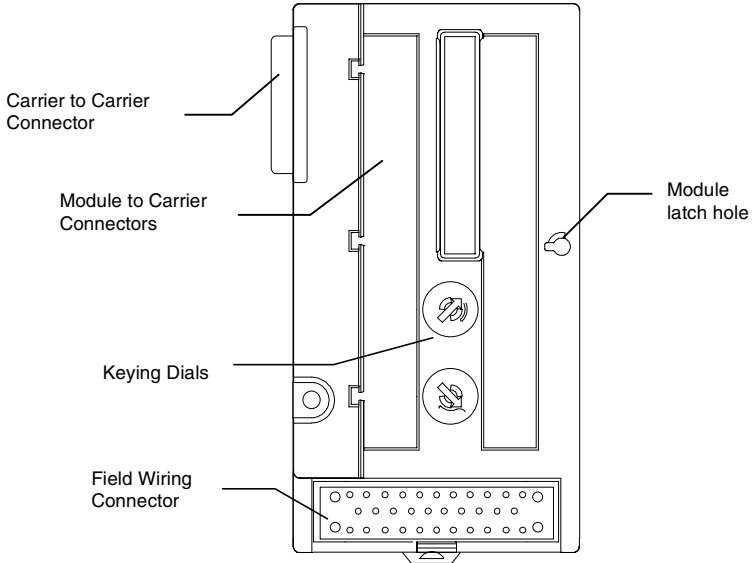

IC200CHS003 Connector-Style I/O Carrier

Field Wiring Connection

I/O devices can be wired directly to Interposing I/O Terminals, described separately in this chapter, or other types of terminal strips.

Connection to the Connector Style I/O Carrier is made by cable. The following cables are available:

IC200CBL105	2 connectors, 0.5m, no shield
IC200CBL110	2 connectors, 1.0m, no shield
IC200CBL120	2 connectors, 2.0m, no shield
IC200CBL230	1 connector, 3.0m, no shield

The notch on the connector indicates the orientation of the pins.

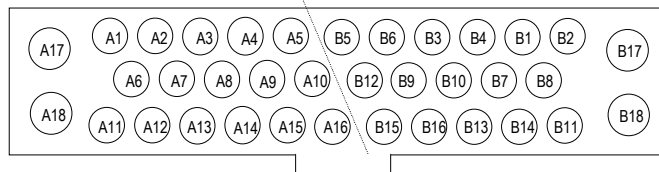

A connector kit is available for building custom cables. The kit is part number IC200ACC304.

The carrier accommodates current levels up to 2 Amps per point or 8 Amps per each power and ground, and a voltage range of up to 264 VAC. Voltage transients up to 300 VAC will not damage the carrier.

Compatibility

This carrier can be used with all VersaMax I/O modules EXCEPT the following, due to their high isolation requirements:

IC200MDL144	Input 240VAC 4 Point Isolated Module
IC200MDL244	Input 240VAC 8 Point Isolated Module
IC200MDD850	Mixed 240VAC Isolated 4 Point / Output Relay 2.0A Isolated 8 Point Module

**IC200CHS005
Spring-Style I/O Carrier**

The Spring-Style I/O Carrier (IC200CHS005) has 36 spring-clamp style terminals for field wiring. It provides mounting, backplane communications, and field wiring for one I/O module.

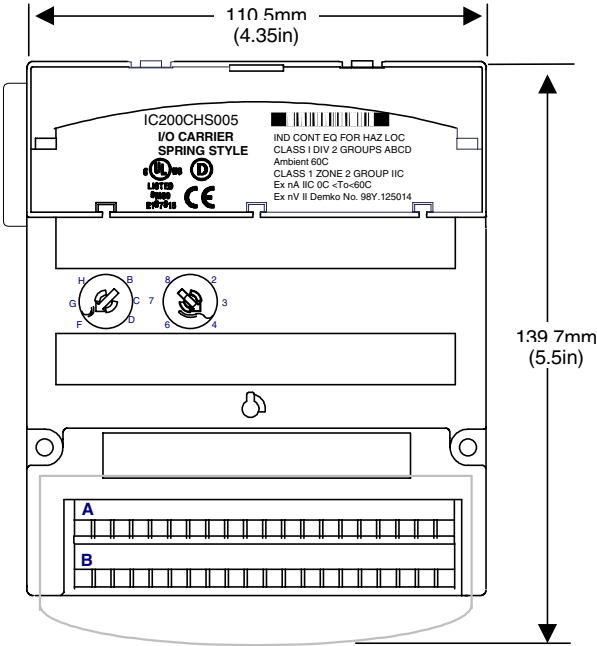

The I/O module mounts lengthwise (parallel to the DIN rail) on this carrier.

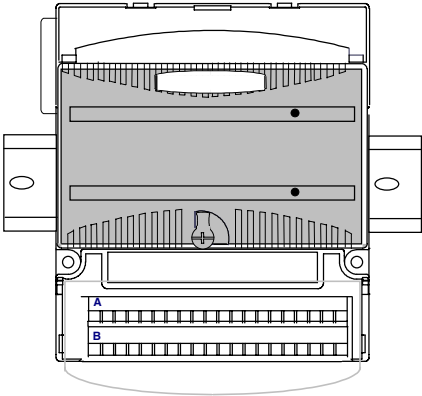

IC200CHS005 Spring-Style I/O Carrier

Din Rail Mounting

The carrier snaps easily onto a 7.5mm X 35mm DIN rail. The DIN rail must be electrically grounded to provide EMC protection. The rail must have a conductive (unpainted) corrosion-resistant finish.

For applications requiring maximum resistance to mechanical vibration and shock, the carrier must also be panel-mounted. See chapter 2 for installation instructions.

Features

- The Spring-Style I/O Carrier supports up to 32 I/O points and 4 common/power connections.
- Easily-set keying dials to assure installation of the correct type of module on the carrier. Keys can be set to match the keying on the bottom of the module. A complete list of module keying is included in appendix D.
- Carrier-to-carrier mating connectors for quick installation of the backplane connection with no additional cables or tools needed.
- Module latch hole for securely fastening the module to the carrier.
- A clear protective hinged door covering the wiring terminals. The printed wiring card provided with each I/O module can be folded and inserted in this door.
- Notches on the lower edge for attaching an Auxiliary I/O Terminal Strip if extra bussed connection points are needed.

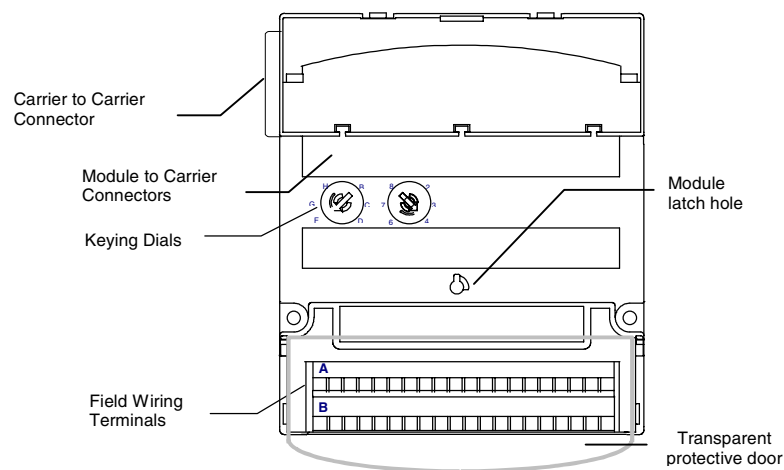

**IC200CHS005
Spring-Style I/O Carrier**

Field Wiring Terminals

Each terminal accommodates one solid or stranded AWG #14 (avg. 2.1mm² cross section) to AWG #22 (avg. 0.36mm² cross section) wire, or two wires up to AWG #18 (avg. 0.86mm² cross section).

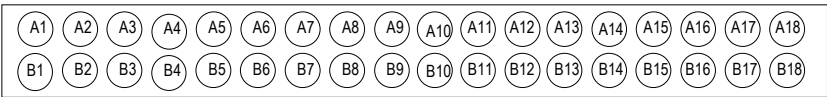

The carrier accommodates current levels up to 2 Amps per point or 8 Amps per each power and ground, and a voltage range of up to 264 VAC. Voltage transients up to 300 VAC will not damage the carrier.

One or more Auxiliary I/O Terminal Strips can be added to provide extra field wiring connections if needed. Auxiliary I/O Terminal Strips insert directly into the lower edge of the I/O Carrier.

IC200CHS022
Compact Box-Style I/O Carrier

The Compact Box-Style I/O Carrier (IC200CHS022) has 36 IEC box-style terminals. It provides mounting, backplane communications, and field wiring for one I/O module.

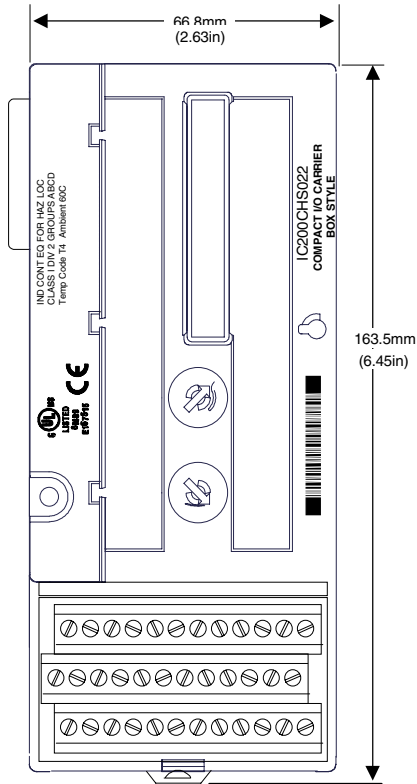

The I/O module mounts vertically (perpendicular to the DIN rail) on this carrier.

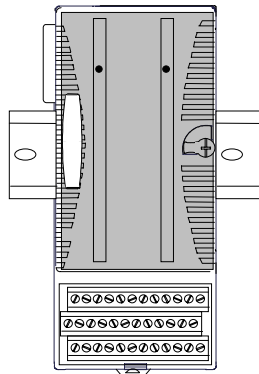

IC200CHS022
Compact Box-Style I/O Carrier

Din Rail Mounting

The I/O carrier snaps easily onto a 7.5mm X 35mm DIN rail. The DIN rail must be electrically grounded to provide EMC protection. The rail must have a conductive (unpainted) corrosion-resistant finish.

For applications requiring maximum resistance to mechanical vibration and shock, the carrier must also be panel-mounted. See chapter 2 for installation instructions.

Features

- The Compact Box-Style I/O carrier supports wiring for up to 32 I/O points and 4 common/power connections.
- Easily-set keying dials to assure installation of the correct type of module on the carrier. Keys are set to match the keying on the bottom of the module. A complete list of module keying assignments is included in appendix D.
- Carrier-to-carrier mating connectors for quick installation of the backplane connection with no additional cables or tools needed.
- Module latch hole for securely fastening the module to the carrier.
- A printed wiring card provided with each I/O module can be folded and inserted in the built-in card holder.

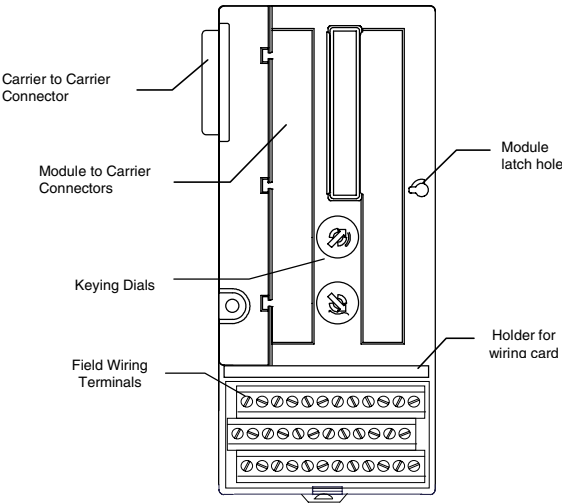

IC200CHS022
Compact Box-Style I/O Carrier

Field Wiring Terminals

Each terminal accommodates one solid or stranded AWG #14 (avg. 2.1mm² cross section) to AWG #22 (avg. 0.36mm² cross section) wire, or two wires up to AWG #18 (avg. 0.86mm² cross section).

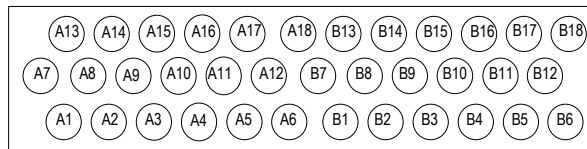

The carrier accommodates current levels up to 2 Amps per point or 8 Amps per each power and ground, and a voltage range of up to 264 VAC. Voltage transients up to 300 VAC will not damage the carrier.

Wiring Card Holder

The Compact I/O Carrier has a built-in card holder that hinges down over the terminal wiring. The wiring card provided with the I/O module can be inserted in the holder. During system operation, the card holder should be in the retracted position.

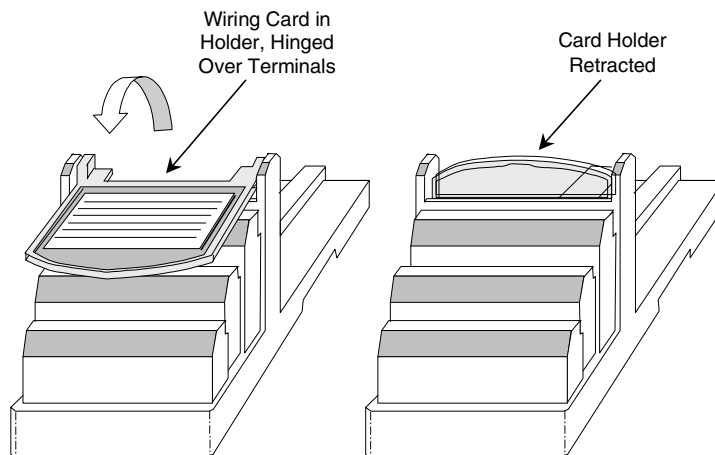

IC200CHS025
Compact Spring-Style I/O Carrier

The Compact Spring-Style I/O Carrier (IC200CHS025) has 36 IEC box-style terminals. It provides mounting, backplane communications, and field wiring for one I/O module.

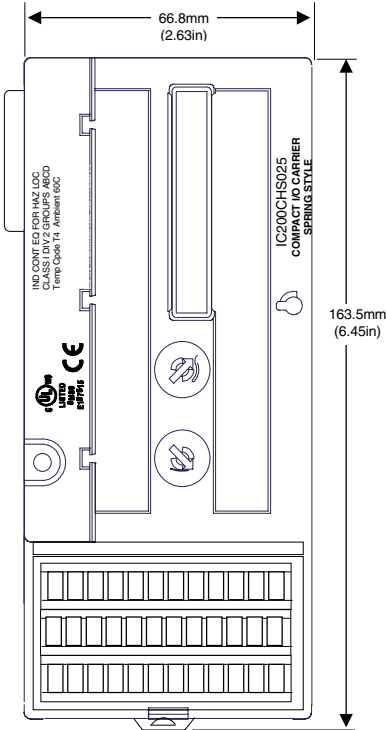

The I/O module mounts vertically (perpendicular to the DIN rail) on this carrier.

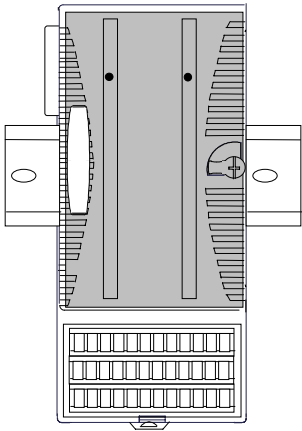

IC200CHS025 Compact Spring-Style I/O Carrier

Din Rail Mounting

The I/O carrier snaps easily onto a 7.5mm X 35mm DIN rail. The DIN rail must be electrically grounded to provide EMC protection. The rail must have a conductive (unpainted) corrosion-resistant finish.

For applications requiring maximum resistance to mechanical vibration and shock, the carrier must also be panel-mounted. See chapter 2 for installation instructions.

Features

- The Compact Spring-Style I/O carrier supports wiring for up to 32 I/O points and 4 common/power connections.
- Easily-set keying dials to assure installation of the correct type of module on the carrier. Keys are set to match the keying on the bottom of the module. A complete list of module keying assignments is included in appendix D.
- Carrier-to-carrier mating connectors for quick installation of the backplane connection with no additional cables or tools needed.
- Module latch hole for securely fastening the module to the carrier.
- A printed wiring card provided with each I/O module can be folded and inserted in the built-in card holder.

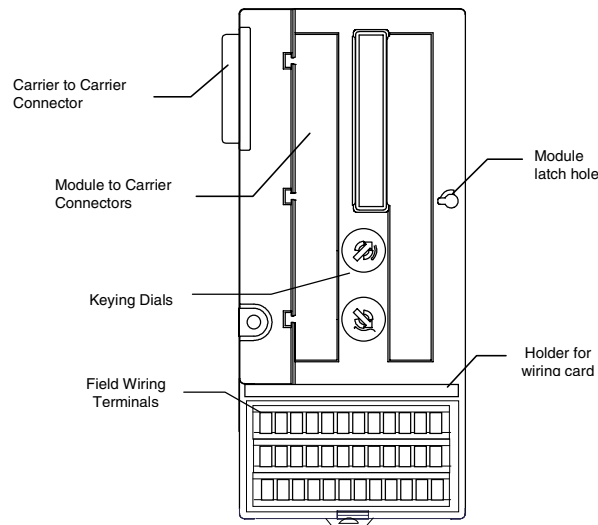

IC200CHS025
Compact Spring-Style I/O Carrier

Field Wiring Terminals

Each terminal accommodates one solid or stranded AWG #14 (avg. 2.1mm² cross section) to AWG #22 (avg. 0.36mm² cross section) wire, or two wires up to AWG #18 (avg. 0.86mm² cross section).

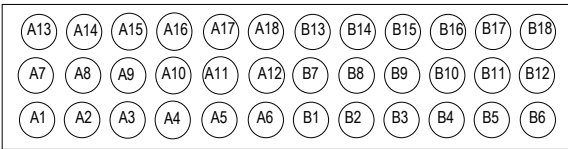

The carrier accommodates current levels up to 2 Amps per point or 8 Amps per each power and ground, and a voltage range of up to 264 VAC. Voltage transients up to 300 VAC will not damage the carrier.

Wiring Card Holder

The Compact I/O Carrier has a built-in card holder that hinges down over the terminal wiring. The wiring card provided with the I/O module can be inserted in the holder. During system operation, the card holder should be in the retracted position.

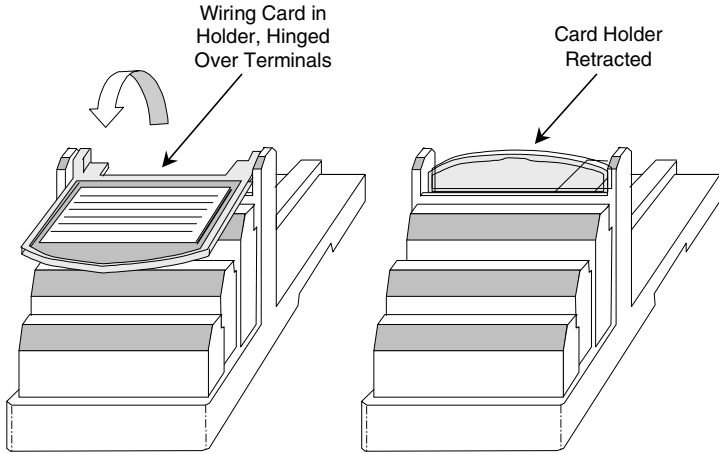

IC200CHS006 Communications Carrier

The Communications Carrier (IC200CHS006) provides mounting and backplane communications and field wiring for a fieldbus communications module.

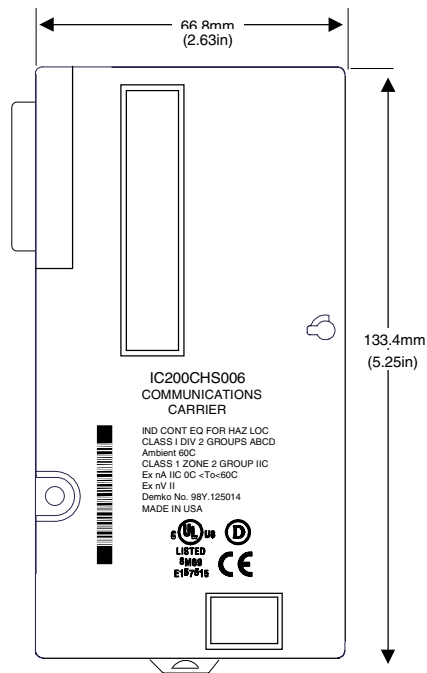

Din Rail Mounting

The carrier snaps easily onto a 7.5mm X 35mm DIN rail. The DIN rail must be electrically grounded to provide EMC protection. The rail must have a conductive (unpainted) corrosion-resistant finish.

For applications requiring maximum resistance to mechanical vibration and shock, the carrier must also be panel-mounted. See chapter 2 for installation instructions.

Features

- Compatible with all VersaMax fieldbus communications modules.
- Fast DIN-rail mounting.
- Can be located in any “slot”.
- Module latch hole for securely fastening the module to the carrier.

IC200PWB001
Power Supply Booster Carrier

Power Supply Booster Carrier IC200PWB001 can be used to mount an additional power supply in sequence with other module carriers. A power supply mounted on a booster carrier provides power to all I/O modules to its right, or until the next booster power supply. The AC or DC Power Supply on the CPU or NIU and the Power Supply that resides on the Booster Carrier must share the same external power source.

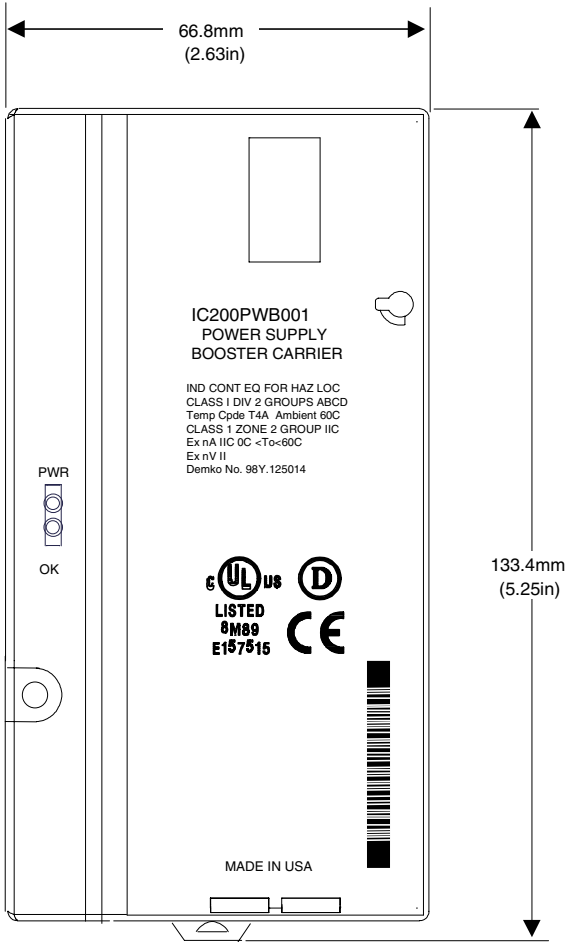

IC200PWB001
Power Supply Booster Carrier**LED Indicators**

Two LEDs on the Power Supply Booster Carrier indicate its status.

PWR	indicates that the attached booster power supply is functioning properly.
OK	indicates that the CPU or NIU and attached booster power supply are functioning properly.

Din Rail Mounting

The Power Supply Booster Carrier snaps easily onto a 7.5mm X 35mm DIN rail. The DIN rail must be electrically grounded to provide EMC protection. The rail must have a conductive (unpainted) corrosion-resistant finish.

For applications requiring maximum resistance to mechanical vibration and shock, the carrier must also be panel-mounted. See chapter 2 for installation instructions.

Chapter 5

Interposing Terminals and Auxiliary I/O Terminal Strips

This chapter describes the Interposing I/O Terminals and Auxiliary I/O Terminal Strips that provide field wiring connections for I/O modules.

- IC200CHS011 Barrier-Style Interposing I/O Terminals
- IC200CHS012 Box-Style Interposing I/O Terminals
- IC200CHS014 Thermocouple-Style Interposing I/O Terminals
- IC200CHS015 Spring-Style Interposing I/O Terminals
- IC200CHS101 Disconnect-Style Interposing I/O Terminals, Main Base
- IC200CHS102 Disconnect-Style Interposing I/O Terminals, Expansion Base
- IC200CHS111 Relay-Style Interposing I/O Terminals, Main Base
- IC200CHS112 Relay-Style Interposing I/O Terminals, Expansion Base
- IC200TBM001 Barrier-Style Auxiliary I/O Terminal Strip
- IC200TBM002 Box-Style Auxiliary I/O Terminal Strip
- IC200TBM005 Spring-Style Auxiliary I/O Terminal Strip

IC200CHS011
Barrier-Style Interposing I/O Terminals

The Barrier-Style Interposing I/O Terminals (IC200CHS011) interface a Connector-Style I/O Carrier to field wiring. The unit has a connector for attaching a cable from the Connector-Style I/O Carrier and 36 barrier-style terminals.

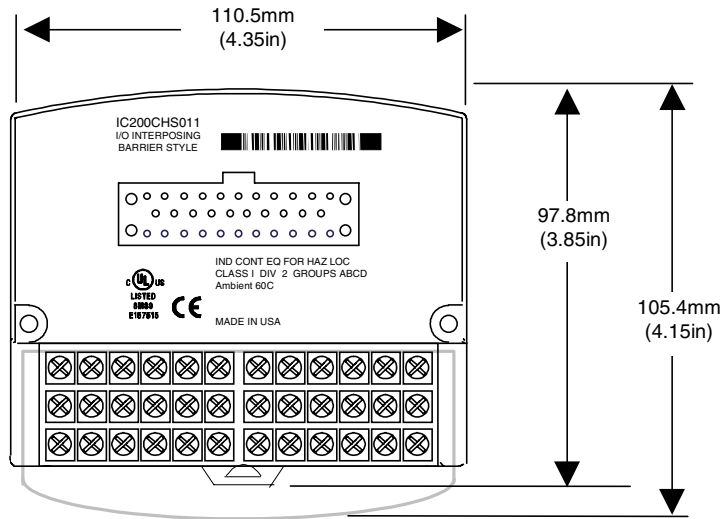

Each terminal accommodates one or two solid or stranded wires up to AWG #14 (avg. 2.1mm² cross section). A clear protective hinged door covers the wiring terminals. The printed wiring card provided with each I/O module can be folded and inserted in this door.

**IC200CHS011
Barrier-Style Interposing I/O Terminals**

Din Rail Mounting

The Interposing I/O Terminals unit can be mounted on the same DIN rail as the Connector-Style I/O Carrier, or on a separate DIN rail as illustrated below. For applications requiring maximum resistance to mechanical vibration and shock, the Interposing I/O Terminals must also be panel-mounted. See chapter 2 for installation instructions.

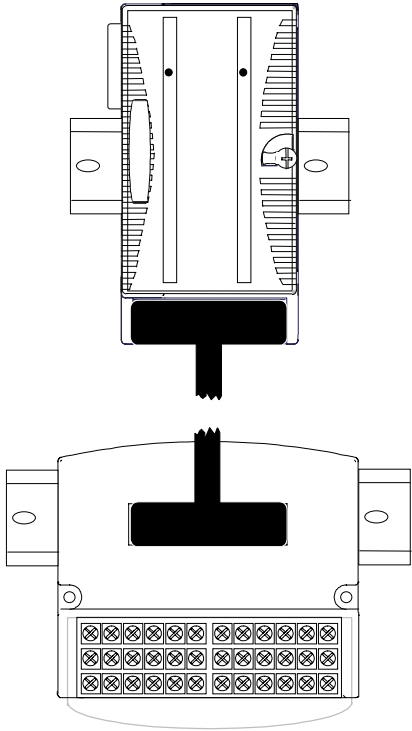

IC200CHS012 Box-Style Interposing I/O Terminals

The Box-Style Interposing I/O Terminals (IC200CHS012) interface a Connector-Style I/O Carrier to field wiring. The unit has a connector for attaching a cable from the Connector-Style I/O Carrier and 36 box-style terminals.

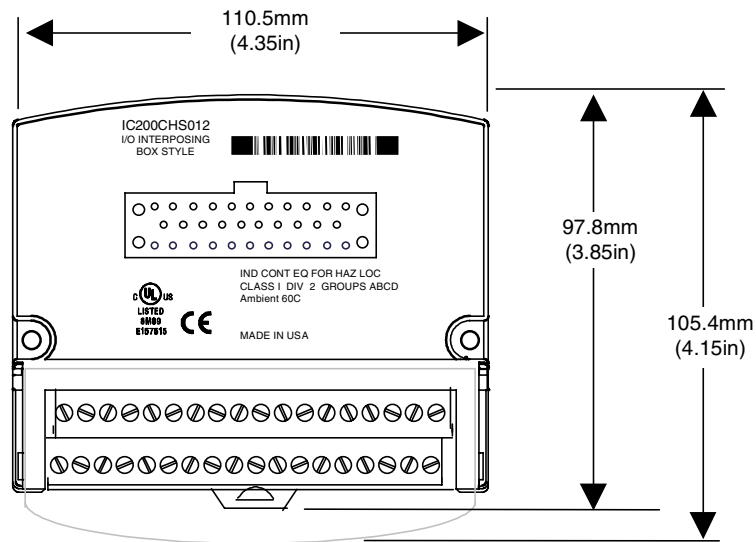

Each terminal accommodates one solid or stranded AWG #14 (avg. 2.1mm² cross section) to AWG #22 (avg. 0.36mm² cross section) wire, or two wires up to AWG #18 (avg. 0.86mm² cross section). A clear protective hinged door covers the wiring terminals. The printed wiring card provided with each I/O module can be folded and inserted in this door.

IC200CHS012
Box-Style Interposing I/O Terminals

Din Rail Mounting

The Interposing I/O Terminals unit can be mounted on the same DIN rail as the Connector-Style I/O Carrier, or on a separate DIN rail as illustrated below. For applications requiring maximum resistance to mechanical vibration and shock, the Interposing I/O Terminals unit must also be panel-mounted. See chapter 2 for installation instructions.

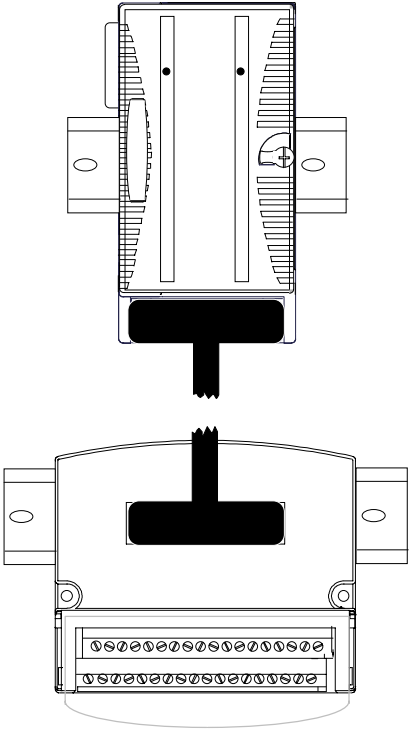

IC200CHS014
Thermocouple Compensation Box-Style Interposing I/O Terminals

The Thermocouple Compensation Box-Style Interposing I/O Terminals (IC200CHS014) interface a Connector-Style I/O Carrier to field wiring from thermocouples. The unit has a connector for attaching a cable from the Connector-Style I/O Carrier and 36 box-style terminals. It includes a built-in thermistor that provides Local Cold Junction Compensation for thermocouple input measurements.

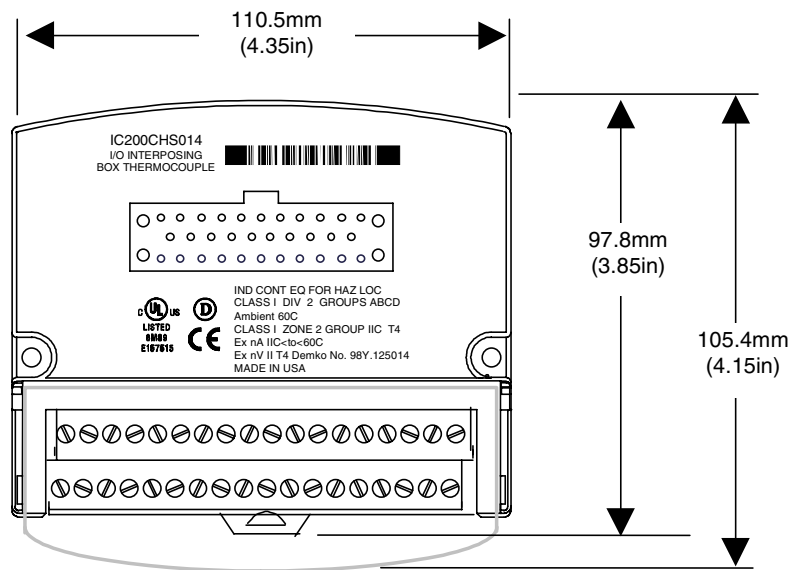

Each terminal accommodates one solid or stranded AWG #14 (avg. 2.1mm² cross section) to AWG #22 (avg. 0.36mm² cross section) wire, or two wires up to AWG #18 (avg. 0.86mm² cross section). A clear protective hinged door covers the wiring terminals. The printed wiring card provided with each I/O module can be folded and inserted in this door.

IC200CHS014
Thermocouple Compensation Box-Style Interposing I/O Terminals

Din Rail Mounting

The Interposing I/O Terminals unit can be mounted on the same DIN rail as the Connector-Style I/O Carrier, or on a separate DIN rail as illustrated below. For applications requiring maximum resistance to mechanical vibration and shock, the Interposing I/O Terminals unit must also be panel-mounted. See chapter 2 for installation instructions.

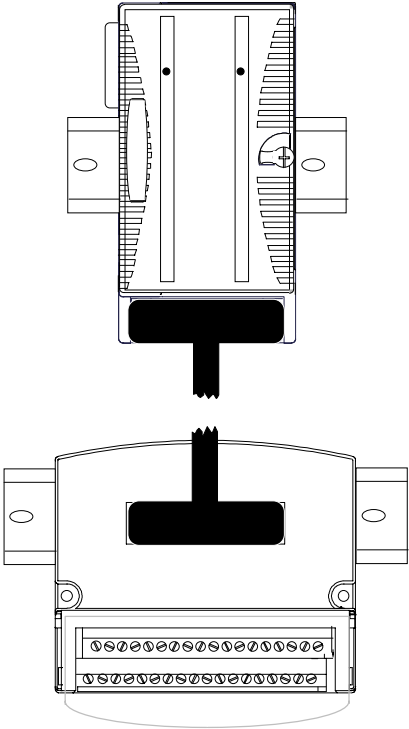

**IC200CHS015
Spring-Style Interposing I/O Terminals**

The Spring-Style Interposing I/O Terminals (IC200CHS015) interface a Connector-Style I/O Carrier to field wiring. It has a connector for attaching a cable from the Connector-Style I/O Carrier and 36 spring-clamp style terminals.

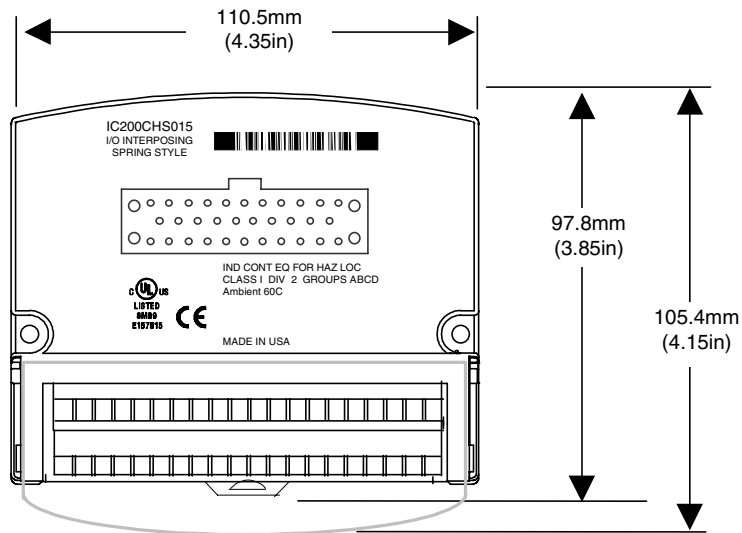

Each terminal accommodates one solid or stranded AWG #14 (avg. 2.1mm² cross section) to AWG #22 (avg. 0.36mm² cross section) wire, or two wires up to AWG #18 (avg. 0.86mm² cross section). A clear protective hinged door covers the wiring terminals. The printed wiring card provided with each I/O module can be folded and inserted in this door.

**IC200CHS015
Spring-Style Interposing I/O Terminals**

Din Rail Mounting

The Interposing I/O Terminals can be mounted on the same DIN rail as the Connector-Style I/O Carrier, or on a separate DIN rail as illustrated below. For applications requiring maximum resistance to mechanical vibration and shock, the Interposing I/O Terminals must also be panel-mounted. See chapter 2 for installation instructions.

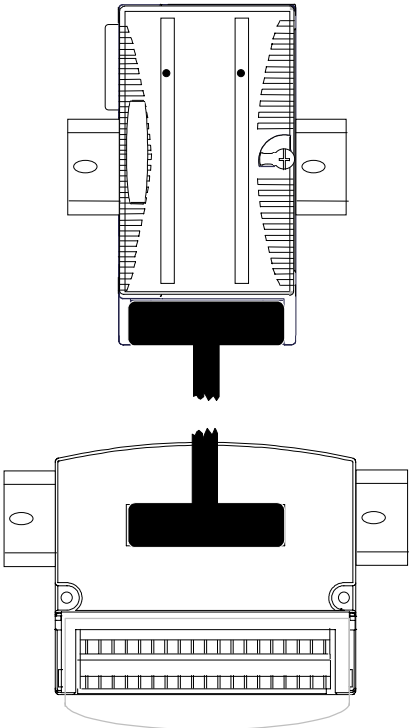

IC200CHS101, Main Base
IC200CHS102, Expansion Base
Disconnect-Style Interposing I/O Terminals

The Disconnect-Style Interposing I/O Terminals (IC200CHS101 and IC200CHS102) interface a VersaMax Connector-Style I/O Carrier to field wiring and provide an integrated disconnect option for field devices connected to VersaMax I/O modules.

Each device connected to the VersaMax I/O module may be individually disconnected from the control circuit by opening one of the two switches (signal or return) associated with it. In this way, specific inputs or outputs may be taken "off line" without altering system wiring or affecting the balance of the installation.

Main and Expansion Base

Two different versions of the Disconnect-Style Interposing I/O Terminals are available, the main and expansion bases. The Main Base, IC200CHS101, provides terminals that correspond to the "A" terminals on a VersaMax I/O module. If the I/O module also has "B" terminals, an Expansion Base, IC200CHS102) is also needed.

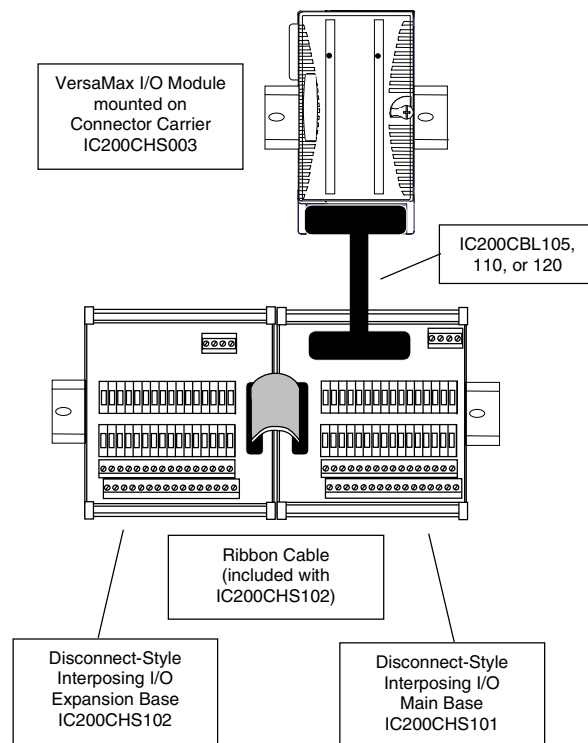

**Main Base, IC200CHS101
Expansion Base, IC200CHS102
Disconnect-Style Interposing I/O Terminals**

Main Base – IC200CHS101

This Interposing Disconnect Base has a connector (J1) for attaching a cable from the Connector-Style I/O Carrier and 36 box-style terminals for field I/O wiring and power connections. The I/O Interposing Disconnect Base also has an expansion connector (J2) that can be used to attach to an Interposing Disconnect Expansion Base (IC200CHS102).

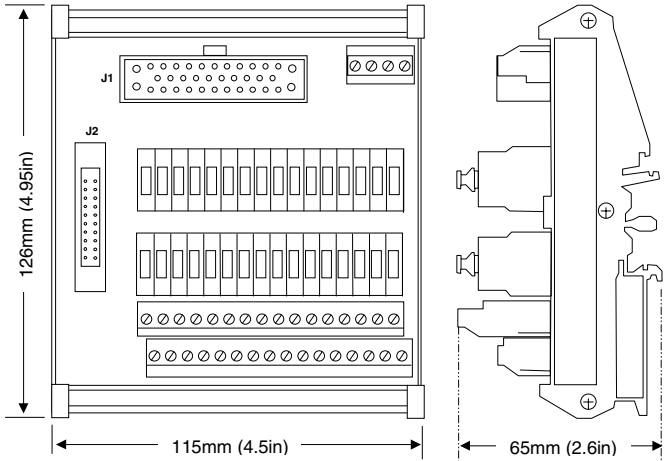

This base provides connection for the terminals on the “A” side of the VersaMax connector (A1-A18). Two groups of common terminals (W1-W8 and X1-X8) can be used for connecting two-wire devices without additional auxiliary terminal blocks.

The base has an individual knife-switch disconnect for each signal and common terminal and its corresponding pin on the VersaMax cable connector.

IC200CHS101, Main Base
IC200CHS102, Expansion Base
Disconnect-Style Interposing I/O Terminals

Expansion Base – IC200CHS102

The Interposing Disconnect Expansion Base has a connector (J2) for attaching a ribbon cable to the expansion connector of the Main Base (IC200CHS101) and 36 box-style terminals for field I/O wiring and power connections. The Expansion base includes a ribbon cable for connecting the expansion base to the main base.

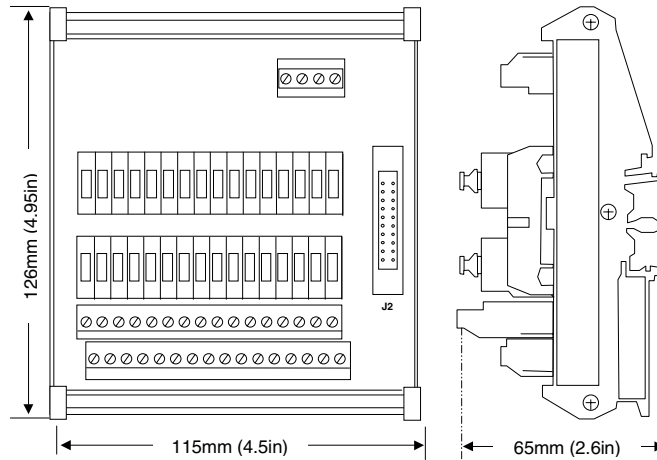

The Expansion Base provides connection for terminals on the “B” side of the VersaMax connector (B1-B18). In addition, it has two groups of common terminals (Y1-Y8 and Z1-Z8) for connecting two-wire devices without additional auxiliary terminal blocks.

The base has an individual knife-switch disconnect for each signal and common terminal and its corresponding pin on the VersaMax cable connector.

**Main Base, IC200CHS101
Expansion Base, IC200CHS102
Disconnect-Style Interposing I/O Terminals**

Compatible I/O Modules

The following table provides a guideline for selecting the appropriate bases and wiring formats for VersaMax I/O modules. Modules that are incompatible with these Interposing Disconnect Bases are indicated by shaded entries in the table.

	1 Group /Row	2 Groups /Row	Not Grouped	CHS101	CHS102	Notes
Discrete Inputs						
IC200MDL140		X*		X		See below.
IC200MDL141		X*		X		See below.
IC200MDL143			X	X		
IC200MDL144	Module not compatible with VersaMax Connector Base					
IC200MDL240		X*		X	X	See below.
IC200MDL241		X*		X	X	See below.
IC200MDL243			X	X	X	
IC200MDL244	Module not compatible with VersaMax Connector Base					
IC200MDL631			X	X		
IC200MDL632			X	X	X	
IC200MDL635		X		X		
IC200MDL636		X		X	X	
IC200MDL640		X		X		
IC200MDL643		X		X		
IC200MDL644		X		X	X	
IC200MDL650		X		X	X	
Discrete Outputs						
IC200MDL329			X	X		
IC200MDL330			X	X	X	
IC200MDL331						No direct connectivity to B row
IC200MDL730						
IC200MDL740	X			X		
IC200MDL741	X			X		
IC200MDL742	X			X	X	
IC200MDL743	X			X		
IC200MDL744	X			X	X	
IC200MDL750	X			X	X	
IC200MDL930			X	X		
IC200MDL940			X	X	X	
Discrete Mixed						
IC200MDD840	Non-symmetric distribution of inputs & outputs					
IC200MDD842	X	X		X	X	1 Group/Row, Outputs, 2 Groups/Row, Inputs
IC200MDD843	Non-symmetric distribution of inputs & outputs					
IC200MDD844	X	X		X	X	1 Group/Row for Outputs, 2 Groups/Row for Inputs
IC200MDD845		X	X	X	X	
IC200MDD846		X*	X	X	X	Not Grouped for Outputs, 1 Group/Row for Inputs. See below.
IC200MDD847		X*	X	X	X	
IC200MDD848		X*	X	X	X	
IC200MDD849			X	X	X	
IC200MDD850	Module not compatible with VersaMax Connector Base					
IC200MDD851	X	X		X	X	1 Group/Row, Outputs, 2 Groups/Row, Inputs

* Variation of the one-group per row format - return groups W & X should be jumpered to terminal A17.

**IC200CHS111, Main Base
 IC200CHS112, Expansion Base
 Relay-Style Interposing I/O Terminals**

The Relay-Style Interposing I/O Terminals (IC200CHS111 and IC200CHS112) each provide dry contacts capable of switching high current outputs (up to 8A). The relays on these interposing terminals are intended to be controlled with standard 24VDC 0.5A VersaMax output modules (IC200MDL740 and IC200MDL750). Each relay is replaceable, individually fused, and includes status indication.

Main and Expansion Base

Two different versions of the Relay-Style Interposing I/O Terminals are available, the main and expansion bases. The Main Base, IC200CHS111, is for use with the 16 point VersaMax module (IC200MDL740) or points 1-16 of the 32 point VersaMax module (IC200MDL750). The Expansion Base, IC200CHS112, is for use with points 17-32 of the 32 point VersaMax module (IC200MDL750).

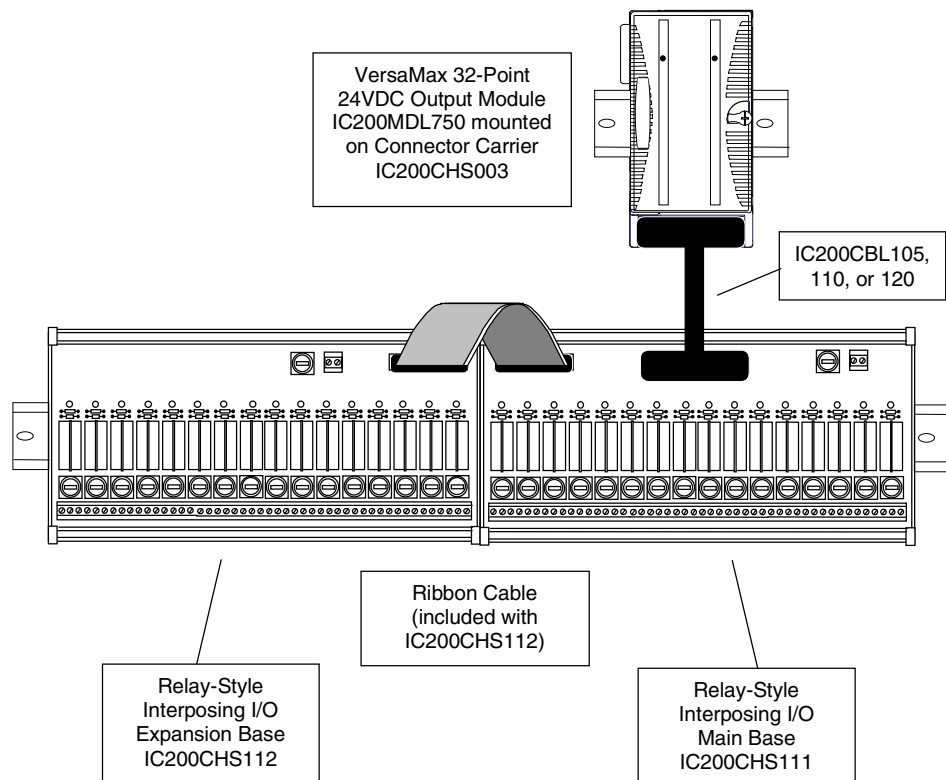

**Main Base, IC200CHS111
Expansion Base, IC200CHS112
Relay-Style Interposing I/O Terminals**

Main Base – IC200CHS111

The Interposing Relay Base has a connector (J1) for attaching a cable from the Connector-Style I/O Carrier (IC200CHS003) and 50 box-style terminals for field I/O wiring and power connections. The Interposing Relay Base also has an expansion connector (J2) that can be used to attach to an Interposing Relay Expansion Base (IC200CHS112).

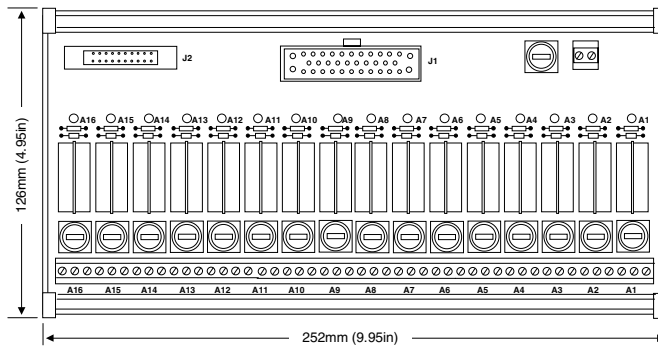

Expansion Base – IC200CHS112

The Interposing Relay Expansion Base has a connector (J2) for attaching a ribbon cable to the expansion connector of the Main Base (IC200CHS111) and 50 box-style terminals for field I/O wiring and power connections. The Expansion base includes a ribbon cable for connecting the expansion base to the main base.

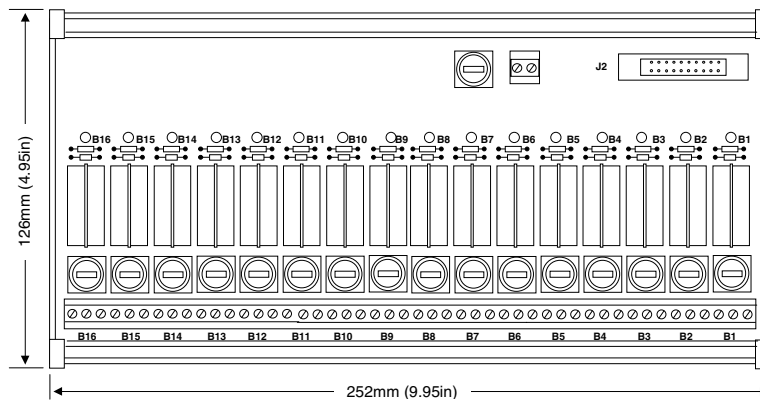

**IC200CHS111, Main Base
 IC200CHS112, Expansion Base
 Relay-Style Interposing I/O Terminals**

Field Wiring

Power for operation of the relay coils must be provided by an external 24VDC power supply. This power must be provided to both the main base and the expansion base. Connection of this external power supply is made at the terminals A17 & A18 (B17 & B18 for the expansion base). This power connection is for the relay coils only. **User loads must be powered by an external source.**

Each relay, status LED and fuse is labeled to indicate the specific point on the VersaMax output module they are associated with. Components labeled A1-A16 correspond to points Q1-Q16. Components labeled B1-B16 correspond to points Q17-Q32. Each point is associated with 3 terminal connections, labeled NO (Normally Open), C (Common), and NC (Normally Closed). User loads may be connected between C and NO, C and NC, or both.

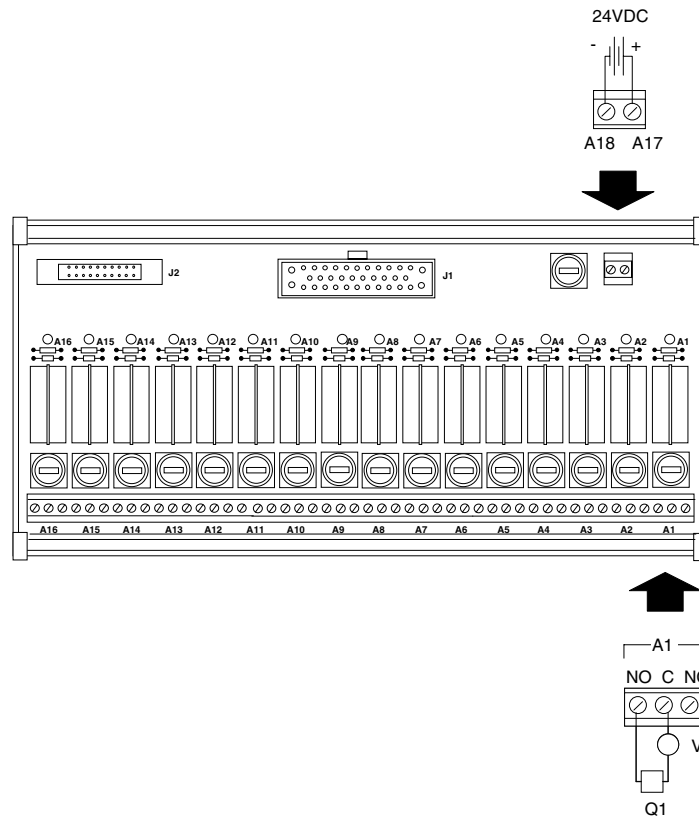

Main Base, IC200CHS111
Expansion Base, IC200CHS112
Relay-Style Interposing I/O Terminals

Relay Specifications

The field-replaceable, form-C relay used in IC200CHS111 and IC200CHS112 is manufactured by Omron Electronics (part number G2R-14). The relay has the following specifications:

Contact Ratings		
Number of Poles	1 Pole	
Load	Resistive Load ($\cos\Phi = 1$)	Inductive Load ($\cos\Phi = 0.4$, L/R = 7ms)
Rated Load	8A at 250VAC 8A at 30VDC	6A at 250VAC 4A at 30VDC
Rated Carry Current	8A	
Max Switching Voltage	380VAC, 125VDC	
Max Switching Current	8A	
Max Switching Power	2,000VA, 240W	1,500VA, 120W
Min Permissible Load	100mA at 5VDC	

Characteristics	
Contact Resistance	30 m Ω max
Operate (set) Time	15 ms max
Release (reset) Time	AC: 10 ms max; DC: 5ms max
Max Operating Frequency	Mechanical: 18,000 operations/hr Electrical: 1,800 operations/hr (under rated load)
Insulation Resistance	1,000 M Ω min (at 500VDC)
Dielectric Strength	5,000 VAC, 50/60 Hz for 1 min between coil and contact 1,000 VAC, 50/60 Hz for 1 min between contacts of the same polarity
Vibration Resistance	Destruction: 10 to 55Hz, 1.5mm double amplitude Malfunction: 10 to 55Hz, 1.5mm double amplitude
Shock Resistance	Destruction: 1,000 m/s ² Malfunction: 200 m/s ² when energized; 100 m/s ² when not energized
Life Expectancy	Mechanical: 20,000,000 operations min (at 18,000 ops/hour) 100,000 operations min (at 1,800 ops/hr under rated load) Electrical
Ambient Temperature	Operating: -40°C to 70°C (with no icing) Storage: -40°C to 70°C (with no icing)
Ambient Humidity	Operating: 35% to 85% Storage: 35% to 85%

**IC200CHS111, Main Base
 IC200CHS112, Expansion Base
 Relay-Style Interposing I/O Terminals**

Switching Current

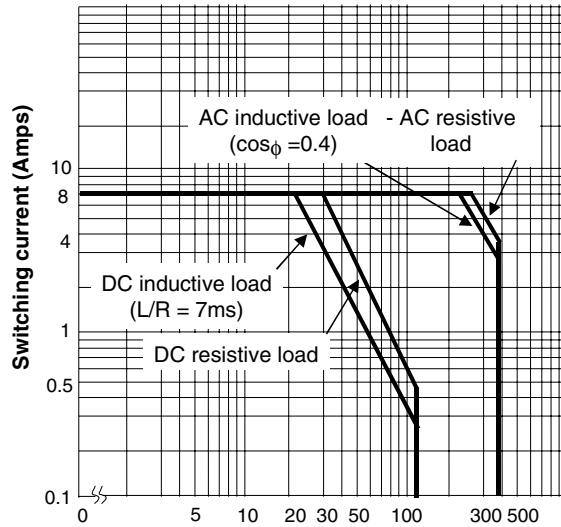

Life Expectancy

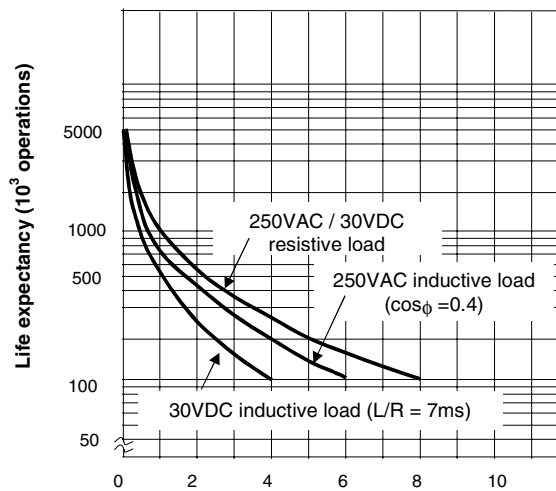

IC200TBM001
Barrier-Style Auxiliary I/O Terminal Strip

The Barrier-Style Auxiliary I/O Terminal Strip (IC200TBM001) has two groups of 6 internally-bussed barrier-style wiring terminals. The two groups are isolated from each other. It can be used to provide extra field wiring connections for terminal-style I/O Carriers and Interposing I/O Terminals.

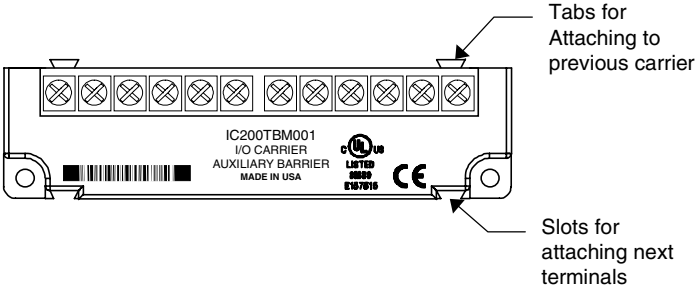

Mounting tabs on the upper edge of the Auxiliary I/O Terminal Strips insert in slots on the bottom of the I/O Carrier or Interposing I/O Terminals for fast, convenient installation. Additional Auxiliary I/O Terminal Strips can be connected in the same way. The Auxiliary I/O Terminal Strip also has panel-mount holes for added stability in high-vibration locations.

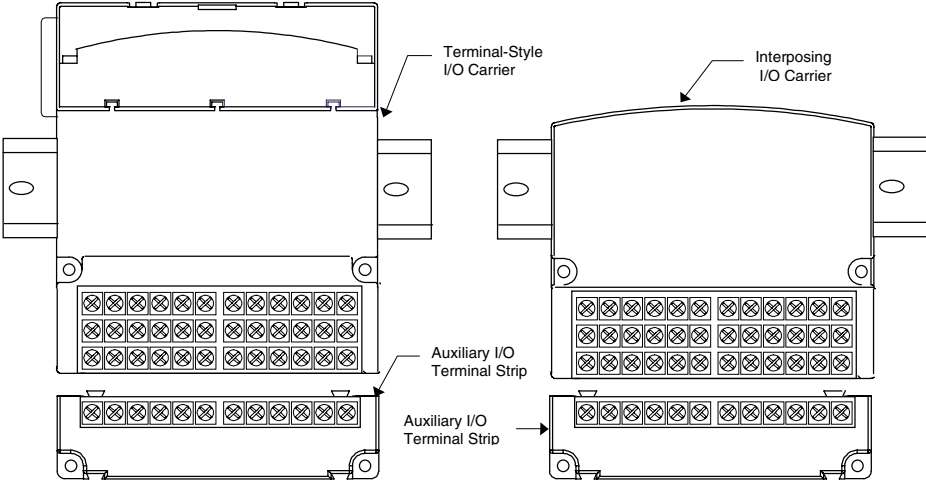

The Auxiliary I/O Terminal Strip can accommodate current levels up to 8 Amps and voltage up to 264 VAC. Voltage levels up to 300VAC will not damage the unit.

There is no electrical connection from the Terminal-Style I/O Carrier or Interposing I/O Terminals to the Auxiliary I/O Terminal Strip; any necessary electrical reference must be provided.

IC200TBM002
Box-Style Auxiliary I/O Terminal Strip

The Box-Style Auxiliary I/O Terminal Strip (IC200TBM002) has 18 internally -bussed IEC box-style wiring terminals. It can be used to provide extra field wiring connections for terminal-style I/O Carriers and Interposing I/O Terminals.

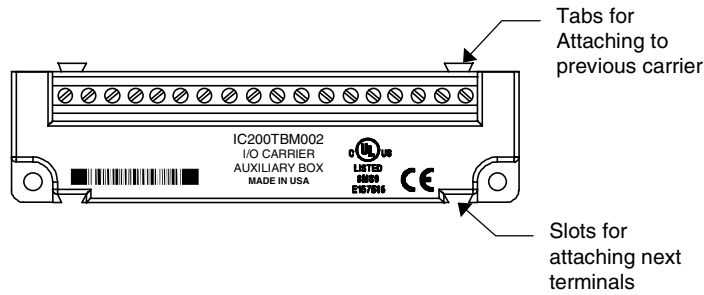

Mounting tabs on the upper edge of the Auxiliary I/O Terminal Strips insert in slots on the bottom of the I/O Carrier or Interposing I/O Terminals for fast, convenient installation. Additional Auxiliary I/O Terminal Strips can be connected in the same way. The Auxiliary I/O Terminal Strip also has panel-mount holes for added stability in high-vibration locations.

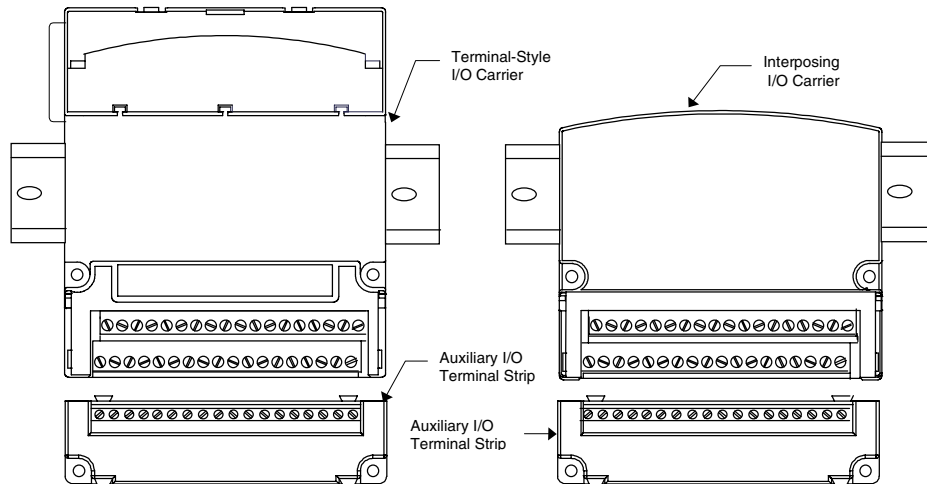

The Auxiliary I/O Terminal Strip can accommodate current levels up to 8 Amps and voltage up to 264 VAC. Voltage levels up to 300VAC will not damage the unit.

There is no electrical connection from the Terminal-Style I/O Carrier or Interposing I/O Terminals to the Auxiliary I/O Terminal Strip; any necessary electrical reference must be provided.

IC200TBM005
Spring-Style Auxiliary I/O Terminal Strip

The Spring-Style Auxiliary I/O Terminal Strip (IC200TBM005) has 18 internally -bussed spring-clamp style wiring terminals. It can be used to provide extra field wiring connections for terminal-style I/O Carriers and Interposing I/O Terminals.

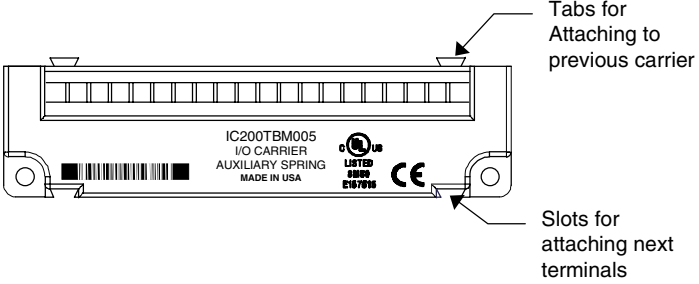

Mounting tabs on the upper edge of the Auxiliary I/O Terminal Strips insert in slots on the bottom of the I/O Carrier or Interposing I/O Terminals for fast, convenient installation. Additional Auxiliary I/O Terminal Strips can be connected in the same way. The Auxiliary I/O Terminal Strip also has panel-mount holes for added stability in high-vibration locations.

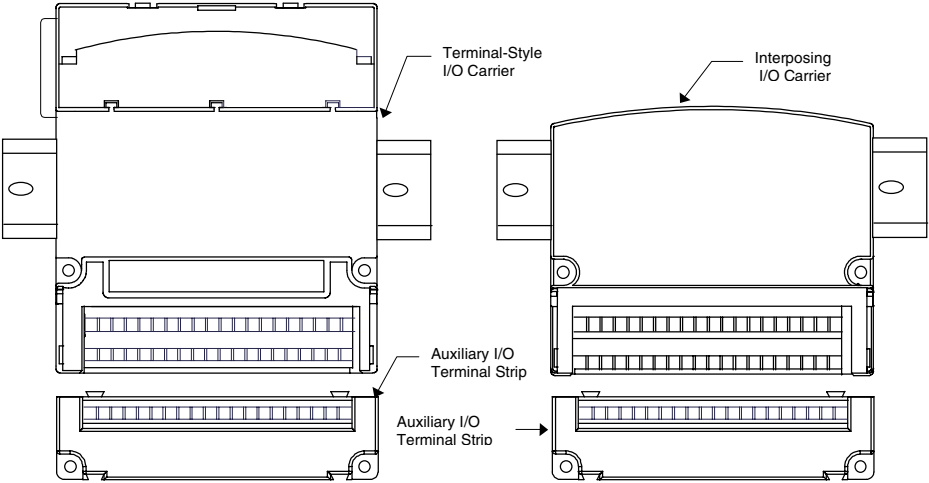

The Auxiliary I/O Terminal Strip can accommodate current levels up to 8 Amps and voltage up to 264 VAC. Voltage levels up to 300VAC will not damage the unit.

There is no electrical connection from the Terminal-Style I/O Carrier or Interposing I/O Terminals to the Auxiliary I/O Terminal Strip; any necessary electrical reference must be provided.

Chapter 6

Expansion Modules

This chapter describes VersaMax expansion modules:

- IC200ETM001 Expansion Transmitter Module
- IC200ERM001 Expansion Receiver Module, Isolated
- IC200ERM002 Expansion Receiver Module, Non-isolated

IC200ETM001 Expansion Transmitter Module

The Expansion Transmitter Module IC200ETM001 (ETM) is used to expand a VersaMax PLC or NIU I/O station to include up to seven additional “racks” of VersaMax modules. Each expansion rack can include up to eight I/O and specialty modules, including the fieldbus communications modules.

The Expansion Transmitter Module has a pass-through serial programming port that can be used to upload firmware updates to an adjacent NIU.



Features

- High speed bus expansion interface
- Serial firmware update interface for updating firmware in adjacent Network Interface Units (NIUs)
- Supports up to 7 expansion racks
- Two LEDs show module power status and expansion port status
- No DIP switches to set, easy software configuration into PLC system

IC200ETM001
Expansion Transmitter Module

Connectors

The 26-pin female D-shell connector on the front of the Expansion Transmitter is the expansion port for connecting to an Expansion Receiver Module.

The 16-pin male connector on the upper left side of the Expansion Transmitter is the pass-through serial programming port. It can be used to upload firmware updates to an adjacent NIU.

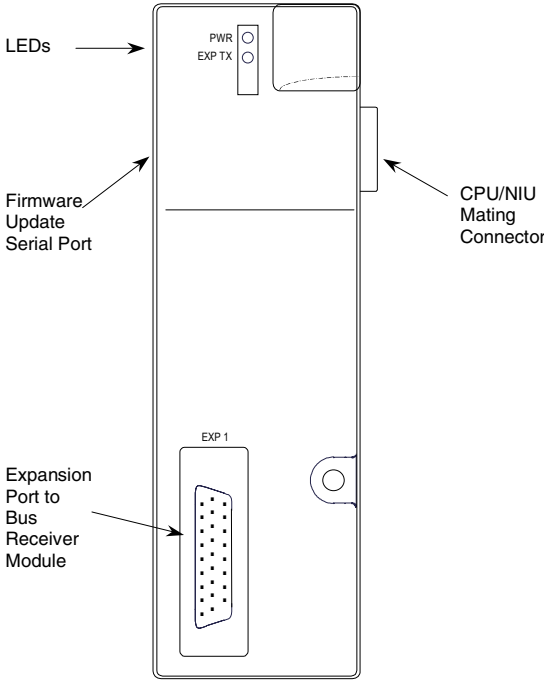

LED Indicators

The LEDs on the Expansion Transmitter show the status of power to the module and the status of the expansion port.

The PWR LED is On when the module is receiving 5VDC power from the CPU or NIU. It is Off when the module is detached from the CPU/NIU or when the CPU/NIU itself is not receiving power.

The EXP TX LED is either blinking or On when the Expansion Transmitter is communicating with the Bus Receiver Modules connected to it through the expansion bus link. It is Off when they are not communicating.

IC200ETM001
Expansion Transmitter Module

Expansion Rack Attachment

The Expansion Transmitter installs on a DIN rail and attaches to the left side of a VersaMax CPU or NIU module on the same DIN rail. The Expansion Transmitter connects to up to seven Expansion Receiver Modules in expansion “racks”. The maximum overall length of the expansion cable depends on which type of Expansion Receiver is used:

- 15 Meters: Expansion Receiver IC200ERM002
- 750 Meters: Isolated Expansion Receiver IC200ERM001

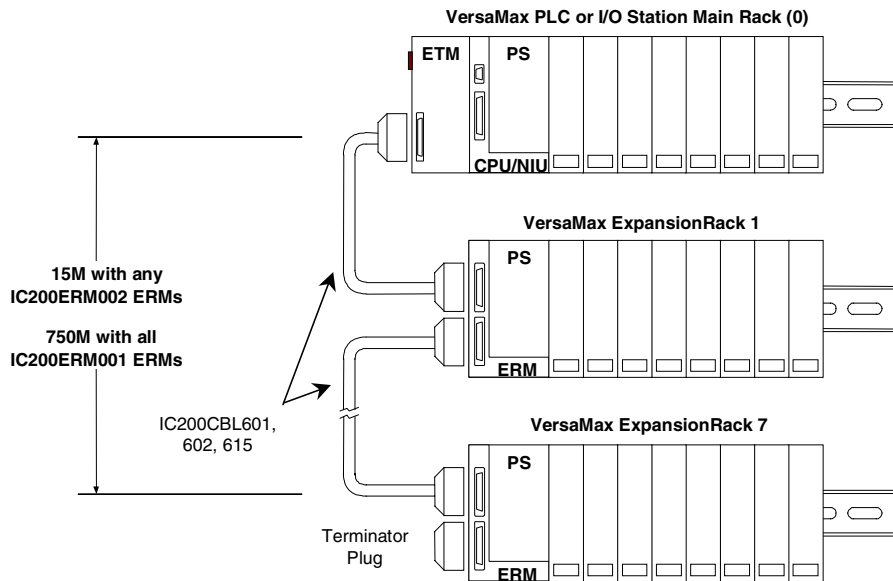

Cable Length and Data Rate

By default, the module is set up to operate with the maximum length expansion cable at the default data rate of 250Kbits/second.

If the total length of the expansion cable is less than 250 meters and there are no non-isolated Expansion Receivers (IC200ERM002) in the expansion system, the VersaMax PLC programmer allows the data rate to be configured to 1Mbit/second. In an NIU I/O Station, the data rate cannot be changed from the default 250Kbits.

Terminator Plug

The last Expansion Receiver in the chain must be terminated with terminator plug IC200ACC201 (included with the Expansion Transmitter). Spare Terminator Plugs may also be purchased separately as part number IC200ACC201 (qty 2).

IC200ETM001
Expansion Transmitter Module

Pass-Through Serial Port

When the Expansion Transmitter is connected to a Network Interface Unit (NIU) module in an I/O station, firmware upgrades to the NIU are performed via the Expansion Transmitter's pass-through serial port. (If there is no Expansion Transmitter installed, firmware upgrades are made via direct connection between the programmer and NIU, as shown first in the illustration below.) The same serial cable, IC200CBL002, is used in both cases.

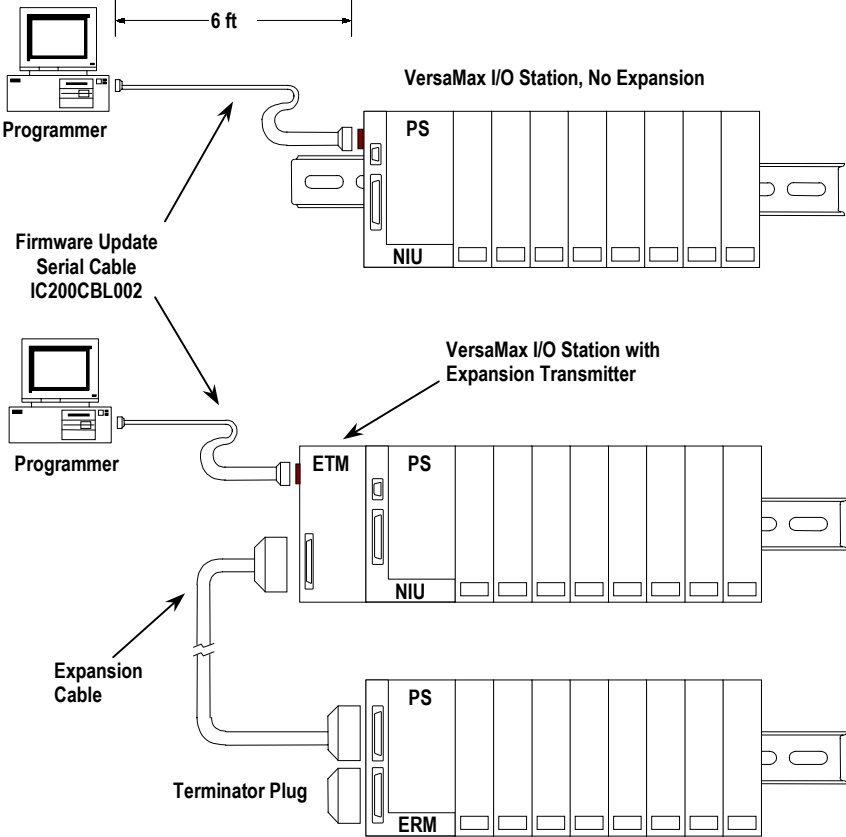

IC200ETM001 Expansion Transmitter Module

Module Specifications

Module Characteristics	
Module ID	
LED indicators	PWR LED indicates 5VDC power status EXP TX LED indicates expansion bus communication status
Backplane current consumption	5V output: 44mA maximum
Cable Specifications	
IC200ERM002: Maximum cable length Effective data rate (max) Electrical Isolation	15 meters 5 Mbits/sec non-isolated differential communications
IC200ERM001: Maximum cable length Effective data rate Electrical Isolation	250 meters (if configured for higher data rate) 750 meters (default distance) 1 Mbits/sec (configurable for cable less than 250 meters) 250 Kbits/sec (default data rate) 500 VDC isolated differential communications
Firmware Update Interface Maximum cable length Effective data rate	6 feet See specification for NIU modules (serial lines are pass-through on ETMs)
Catalog Numbers	
Bus Transmitter Module	IC200ETM001
Expansion Cable	IC200CBL601 - 1 meter IC200CBL602 - 2 meters IC200CBL615 - 15 meters
Firmware Update Cable	IC200CBL002
Terminator Plug	IC200ACC201 (included with ETM)
Connector Kit	IC200ACC202

To make different length expansion cables, purchase the connector kit and use one of the following commercially-available cables: Belden 8108, Manhattan/CDT M2493, Alpha 3498C.

IC200ERM001 Expansion Receiver Module, Isolated

The Expansion Receiver Module, Isolated (IC200ERM001) interfaces an expansion “rack” to a VersaMax PLC or NIU I/O Station system. The expansion rack can include up to eight Versamax I/O and special-purpose modules. A VersaMax power supply installed on the Expansion Receiver Module provides operating power for the modules in the expansion rack. This module must be used with an Expansion Transmitter Module (IC200ERM001) in the PLC or I/O Station. The total overall length of the expansion cable can be up to 750 meters. This module provides up to 500VDC isolation.

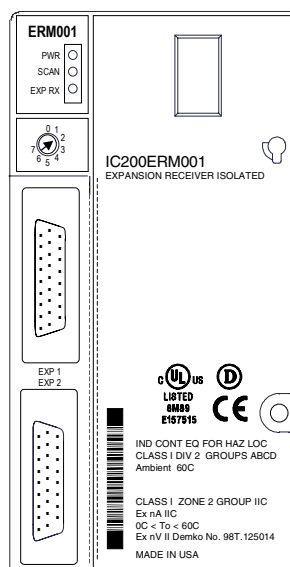

- High speed bus expansion interface
- Supports up to 7 expansion racks
- Supports Hold Last State
- System fault isolation
- Three LED indicators provide module power status and expansion port status
- No DIP switches to set, easy software configuration into PLC system
- Power supply mounts directly to module
- 500 VDC isolation

The Expansion Receiver Module supports hold last state operation of the output modules in the event of loss of communications with the CPU/NIU. It also permits isolation and repair of a faulty module within a rack.

IC200ERM001 Expansion Receiver Module, Isolated

Connectors

The Expansion Receiver has two 26-pin female D-shell expansion ports. The upper port receives the cable from an Expansion Transmitter or upstream Expansion Receiver Module. The lower port is used to daisy-chain the expansion cable to the next expansion rack or to attach the terminator plug at the last rack. The Expansion Receiver must always be installed in the leftmost position of the rack (slot 0).

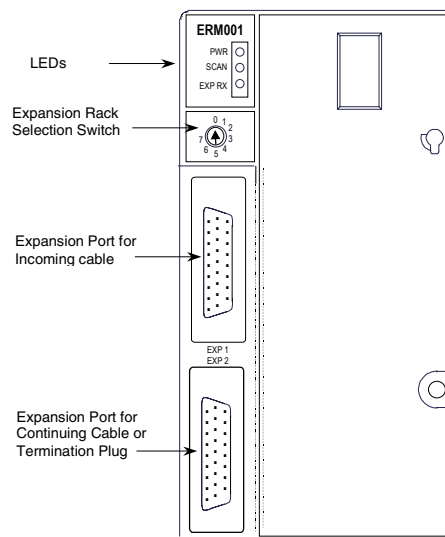

LED Indicators

Three LEDs show the status of module power, the expansion port, and the I/O modules.

The PWR LED is On when the module is receiving 5VDC power from the attached power supply. It is Off when there is no power supply attached or when the power supply itself is not receiving power.

The SCAN LED lights green when the CPU/NIU is actively scanning I/O in expansion racks. It lights amber when the CPU/NIU is not actively scanning I/O in expansion racks.

The EXP RX LED indicates the status of the expansion bus. This LED is either blinking or On when the Expansion Receiver is communicating with the Expansion Transmitter. It is Off when not communicating.

Expansion Rack Selection Switch

The Rack Selection Switch is used to specify which expansion rack the ERM is in.

IC200ERM001
Expansion Receiver Module, Isolated

VersaMax Expansion Modules Standard RS-485 Differential Expansion Interface

The Expansion Receiver Module connects to an Expansion Transmitter Module in a VersaMax PLC or VersaMax NIU I/O Station, or to an Expansion Receiver in a previous rack, as shown below. Modules are connected using expansion cable IC200CBL6xx (xx represents the length in meters). Up to seven expansion racks can be used in a system. With the isolated Expansion Receiver Module, the total overall length of the expansion cable can be up to 750 meters.

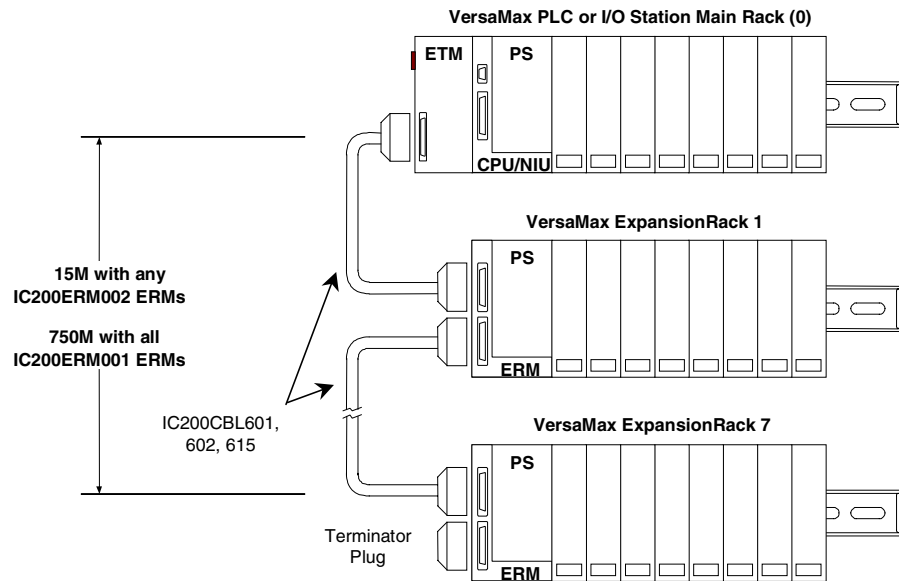

Cable Length and Data Rate

By default, the module is set up to operate with the maximum length expansion cable at the default data rate of 250Kbits/second.

If the total length of the expansion cable is less than 250 meters and there are no non-isolated Expansion Receivers (IC200ERM002) in the expansion system, the VersaMax PLC programmer allows the data rate to be configured to 1Mbit/second. In an NIU I/O Station, the data rate cannot be changed from the default 250Kbits.

Terminator Plug

The terminator plug supplied with the Expansion Transmitter Module must be installed in the lower connector of the last Expansion Receiver in the chain as shown above.

IC200ERM001 Expansion Receiver Module, Isolated

Module Specifications

Module Characteristics	
Module ID	
LED indicators	PWR LED indicates 5VDC power status EXP RX LED indicates status of the expansion bus SCAN indicates whether CPU/NIU is scanning I/O in expansion racks
Backplane current consumption	5V output: 430mA maximum. 3.3V output: 20mA
Cable Specifications	
Maximum cable length	250 meters (if configured for higher data rate) 750 meters (default distance)
Effective data rate	1 Mbits/sec (configurable for cable less than 250 meters) 250 Kbits/sec (default data rate)
Electrical Isolation	500 VDC isolated differential communications
Catalog Numbers	
Bus Receiver Module	IC200ERM001
Bus Transmitter Module	IC200ETM001
Expansion Cable	IC200CBL601 - 1 meter IC200CBL602 - 2 meters IC200CBL615 - 15 meters
Firmware Update Cable	IC200CBL002
Terminator Plug	IC200ACC201 (included with ETM)
Connector Kit	IC200ACC202

Compatibility

All I/O and communications modules can be used in expansion racks. Some analog modules require specific module revisions as listed below. The date code is a 3-digit number on the outside of the module and on the shipping box.

Module	Module Revision	Module Date Code Range
IC200ALG320	B or later	Any
IC200ALG321	B or later	Any
IC200ALG322	B or later	Any
IC200ALG430	C or later	Any
IC200ALG431	C or later	Any
IC200ALG432	B or later	Any
IC200ALG230	A or later	<i>CPU or NIU Revision 1.5:</i> Date code must begin with a number other than 9 and must be 011 or greater.
	Any	<i>CPU or NIU Revision 2.0 or later:</i> Any date code.
IC200ALG260	A or later	<i>CPU or NIU Revision 1.5:</i> Date code must begin with a number other than 9 and must be 011 or greater.
	Any	<i>CPU or NIU Revision 2.0 or later:</i> Any date code.

IC200ERM002 Expansion Receiver Module, Non-isolated

The non-isolated Expansion Receiver Module (IC200ERM002) interfaces an expansion “rack” to a VersaMax PLC or VersaMax NIU I/O Station system. The expansion rack can include up to eight VersaMax I/O and special-purpose modules. A VersaMax power supply installed on the Expansion Receiver Module provides operating power for the modules in the expansion rack. This module may be used without an Expansion Transmitter Module (IC200ETM001) in the PLC or I/O Station if there is only one expansion rack in the system or if the cable length is one meter or less. An Expansion Transmitter Module is required if there are multiple expansion racks or for a longer cable. Maximum cable length for this non-isolated module is 15 meters.

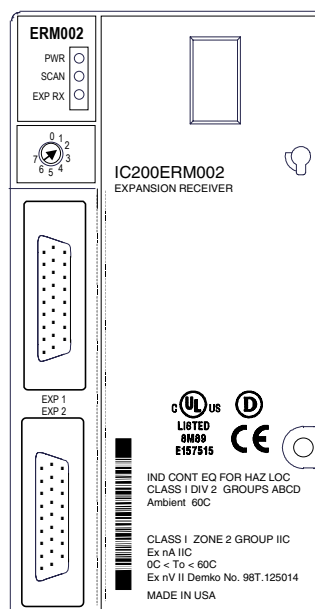

- High speed bus expansion interface
- Supports Hold Last State
- System fault isolation
- Three LEDs indicate module power status and expansion port status
- No DIP switches to set, easy software configuration into PLC system
- Power supply mounts directly to module
- Differential or single-ended operation

The Expansion Receiver Module supports hold last state operation of the output modules in the event of loss of communications with the CPU/NIU. It also permits isolation and repair of a faulty module within a rack.

IC200ERM002 Expansion Receiver Module, Non-isolated

Connectors

The Expansion Receiver has two 26-pin female D-shell expansion ports. The upper port receives the cable from an Expansion Transmitter or upstream Expansion Receiver Module. The lower port is used to connect the expansion cable to the next expansion rack or to attach the terminator plug at the last rack.

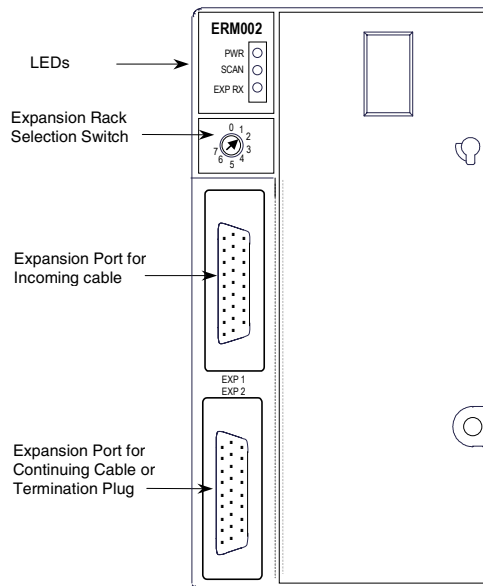

LED Indicators

Three LEDs show the status of module power, the expansion port, and the I/O modules.

The PWR LED is On when the module is receiving 5VDC power from the attached power supply. It is Off when there is no power supply attached or when the power supply itself is not receiving power.

The SCAN LED lights green when the CPU/NIU is actively scanning I/O in expansion racks. It lights amber when the CPU/NIU is not actively scanning I/O in expansion racks.

The EXP RX LED indicates the status of the expansion bus. This LED is either blinking or On when the Expansion Receiver is communicating with the Expansion Transmitter or with other ERMs. It is Off when not communicating.

Expansion Rack Selection Switch

The Rack Selection Switch is used to specify which expansion rack the ERM is in.

IC200ERM002
Expansion Receiver Module, Non-isolated

VersaMax Expansion Modules Standard RS-485 Differential Expansion Interface

The Expansion Receiver Module connects to an Expansion Transmitter Module in a VersaMax PLC or VersaMax NIU I/O Station, or to an Expansion Receiver in a previous rack, as shown below. Modules are connected using expansion cable IC200CBL6xx (xx represents the length in meters). Up to seven expansion racks can be included in the system. With the non-isolated Expansion Receiver Module, the total overall length of the expansion cable can be up to 15 meters.

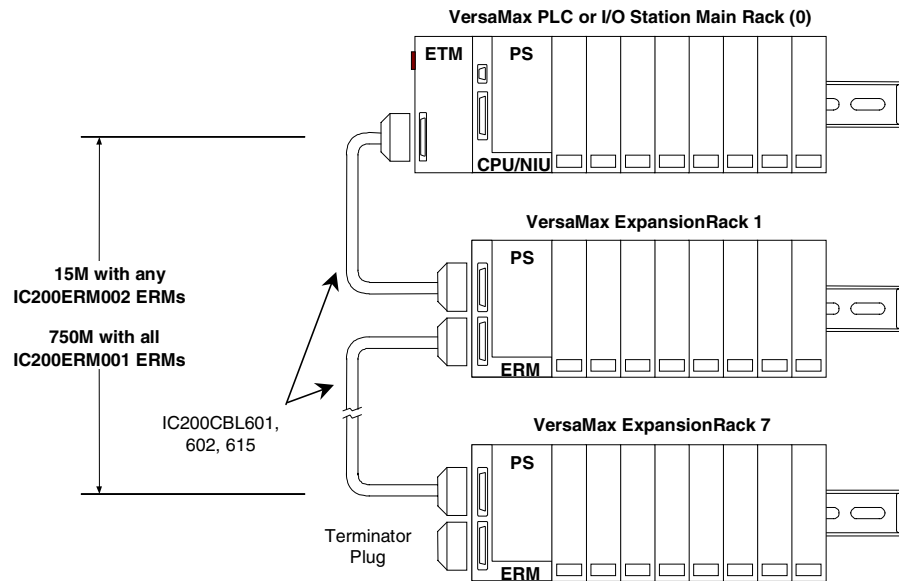

Terminator Plug

The terminator plug supplied with the Expansion Transmitter Module is installed in the last Expansion Receiver in a chain as shown above. If the Expansion Receiver is at the end of the chain, the terminator plug is installed in the lower expansion port.

No terminator plug is required in the single-ended configuration described on the next page.

**IC200ERM002
Expansion Receiver Module, Non-isolated**

Two-Rack Local System

Expansion Receiver IC200ERM002 can also be used to connect a VersaMax PLC main rack or VersaMax NIU I/O Station to just one expansion rack without having an Expansion Transmitter Module in the main rack.

This “single-ended” configuration has a maximum cable length of 1 meter. No terminator plug is required in the expansion rack.

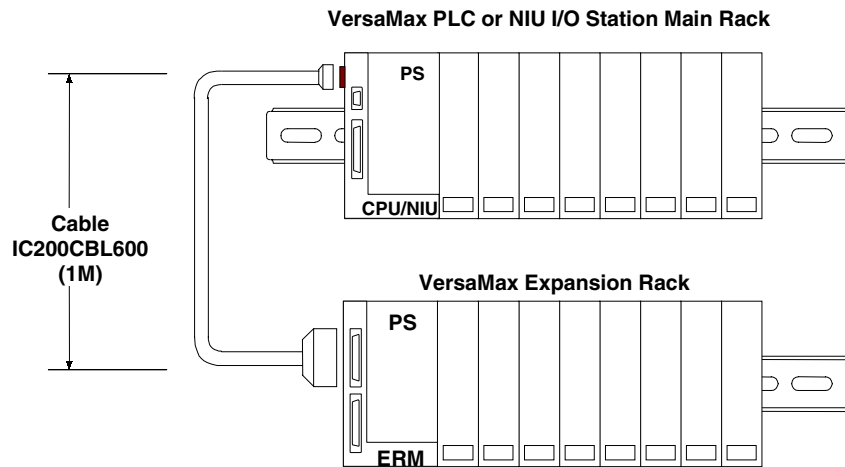

IC200ERM002
Expansion Receiver Module, Non-isolated

Module Specifications

Module Characteristics	
Module ID	
LED indicators	PWR LED indicates 5VDC power status EXP RX LED indicates expansion bus communications status SCAN LED indicates whether the CPU/NIU is scanning I/O in expansion racks
Backplane current consumption	5V output: 70mA maximum 3.3V output: 20mA
Cable Specifications	
Maximum cable length	15 meters (differential) . 1 meter (differential)
Effective data rate	5 Mbits/sec (differential). 2.765 Mbits/sec (single-ended)
Electrical Isolation	Non-isolated differential or single-ended communications
Catalog Numbers	
Bus Receiver Module	IC200ERM002
Expansion Cable	IC200CBL601 - 1 meter IC200CBL602 - 2 meters IC200CBL615 - 15 meters
Terminator Plug	IC200ACC201 (included with ETM)
Connector Kit	IC200ACC202

Compatibility

All I/O and communications modules can be used in expansion racks. Some analog modules require specific module revisions as listed below. The date code is a 3-digit number on the outside of the module and on the shipping box.

Module	Module Revision	Module Date Code Range
IC200ALG320	B or later	Any
IC200ALG321	B or later	Any
IC200ALG322	B or later	Any
IC200ALG430	C or later	Any
IC200ALG431	C or later	Any
IC200ALG432	B or later	Any
IC200ALG230	A or later	<i>CPU or NIU Revision 1.5:</i> Date code must begin with a number other than 9 and must be 011 or greater.
	Any	<i>CPU or NIU Revision 2.0 or later:</i> Any date code.
IC200ALG260	A or later	<i>CPU or NIU Revision 1.5:</i> Date code must begin with a number other than 9 and must be 011 or greater.
	Any	<i>CPU or NIU Revision 2.0 or later:</i> Any date code.

This chapter describes VersaMax discrete input modules:

- IC200MDL140 Input Module, 120VAC 8 Points
- IC200MDL141 Input Module, 240VAC 8 Points
- IC200MDL143 Input Module, 120VAC Isolated 8 Points
- IC200MDL144 Input Module, 240VAC Isolated 4 Points
- IC200MDL240 Input Module, 120VAC 16 Points
- IC200MDL241 Input Module, 240VAC 16 Points
- IC200MDL243 Input Module, 120VAC Isolated 16 Points
- IC200MDL244 Input Module, 240VAC Isolated 8 Points
- IC200MDL631 Input Module, 125VDC Pos/Neg Logic Isolated 8 Points
- IC200MDL632 Input Module, 125VDC Pos/Neg Logic Isolated 16 Points
- IC200MDL635 Input Module, 48VDC Pos/Neg Logic Grouped 16 Points
- IC200MDL636 Input Module, 48VDC Pos/Neg Logic Grouped 32 Points
- IC200MDL640 Input Module, 24VDC Pos/Neg Logic 16 Points
- IC200MDL643 Input Module, 5/12VDC Pos/Neg Logic Grouped 16 Points
- IC200MDL644 Input Module, 5/12VDC Pos/Neg Logic Grouped 32 Point
- IC200MDL650 Input Module, 24VDC Pos/Neg Logic 32 Points

IC200MDL140 **Input Module, 120VAC 8 Points**

Discrete Input Module IC200MDL140 provides one group of 8 discrete inputs. Inputs are positive logic or sourcing-type inputs; they receive current from AC input devices and return the current on the common. Input devices are connected between the input terminals and common terminals.

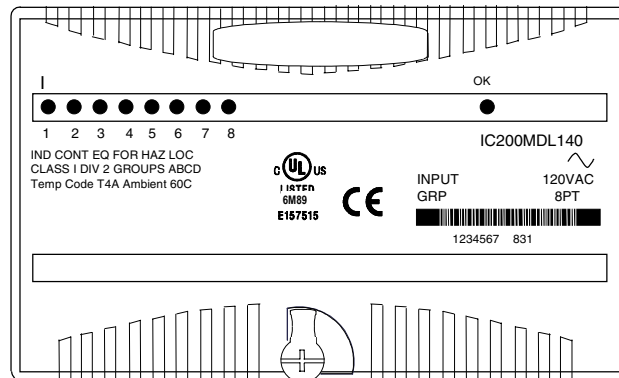

Power for module operation comes from the backplane.

Intelligent processing for the module is performed by the CPU or NIU. The module provides 8 bits of discrete input data.

LED Indicators

Individual green LEDs indicate the on/off state of each input point.

The green OK LED is on when backplane power is present to the module.

IC200MDL140
Input Module, 120VAC 8 Points

Module Specifications

Module Characteristics	
Points	One group of 8 inputs
Module ID	FFF8804
Isolation: User input to logic (optical) and frame ground Group to group Point to point	250VAC continuous; 1500VAC for 1 minute Not applicable None
LED indicators	One LED per point shows individual point ON/OFF status OK LED indicates backplane power is present
Backplane current consumption	5V output: 55mA maximum
External power supply	None
Thermal derating	None
Input Characteristics	
Input voltage	0 to 132VAC (47 to 63Hz), 120VAC nominal
On state voltage Off state voltage	70 to 132VAC 0 to 20VAC
On state current Off state current	5mA minimum 2.5mA maximum
On response time Off response time	1 cycle maximum 2 cycles maximum
Input impedance	8.6kOhms (reactive) at 60Hz, typical 10.32kOhms (reactive) at 50Hz, typical

IC200MDL140
Input Module, 120VAC 8 Points

Field Wiring

Terminal	Connection	Terminal	Connection
A1	Input 1	B1	No connection
A2	Input 2	B2	No connection
A3	Input 3	B3	No connection
A4	Input 4	B4	No connection
A5	Input 5	B5	No connection
A6	Input 6	B6	No connection
A7	Input 7	B7	No connection
A8	Input 8	B8	No connection
A9	No connection	B9	No connection
A10	No connection	B10	No connection
A11	No connection	B11	No connection
A12	No connection	B12	No connection
A13	No connection	B13	No connection
A14	No connection	B14	No connection
A15	No connection	B15	No connection
A16	No connection	B16	No connection
A17	Inputs 1-8 Common (Return)	B17	No connection
A18	No connection	B18	No connection

If additional bussed terminals are needed, the B terminals can be made available by using a shorting bar. The shorting bar has a maximum current-carrying capacity of 2 Amps per point. See chapter 2 for information about using the shorting bar.

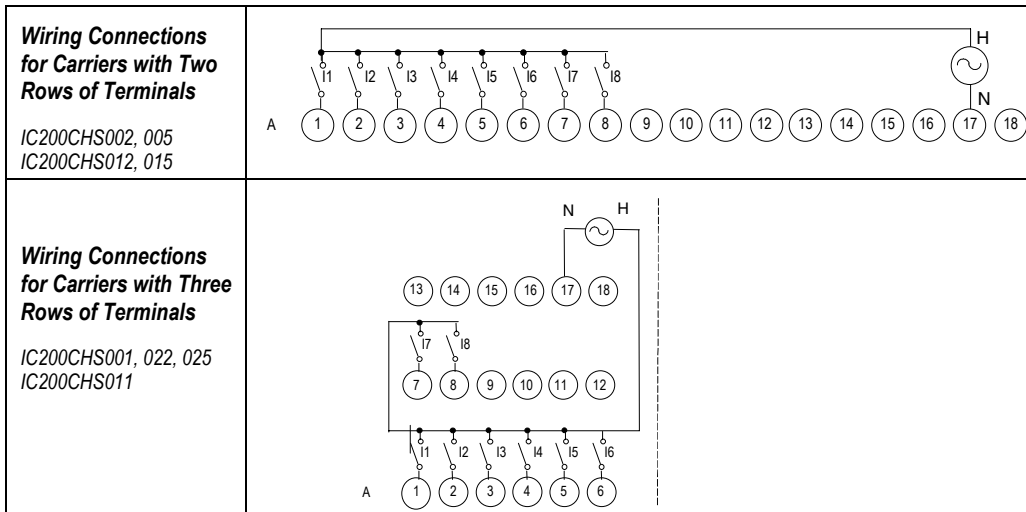

**IC200MDL141
Input Module, 240VAC 8 Points**

Discrete Input Module IC200MDL141 provides one group of 8 discrete inputs. Inputs are positive logic or sourcing-type inputs; they receive current from AC input devices and return the current on the common. Input devices are connected between the input terminals and common terminals.

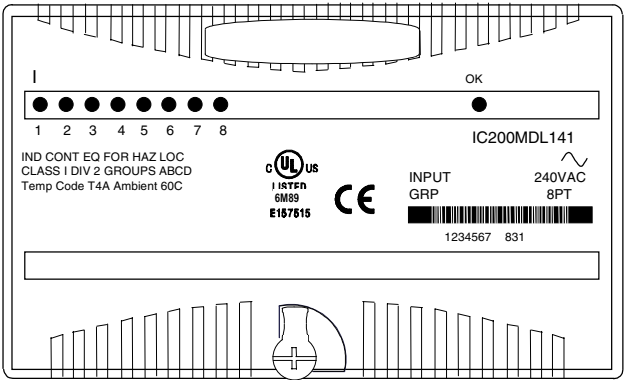

Power for module operation comes from the backplane.

Intelligent processing for the module is performed by the CPU or NIU. The module provides 8 bits of discrete input data.

LED Indicators

Individual green LEDs indicate the on/off state of each input point.

The green OK LED is on when backplane power is present to the module.

IC200MDL141
Input Module, 240VAC 8 Points

Module Specifications

Module Characteristics	
Points	1 group of 8 inputs
Module ID	FFFF8804
Isolation:	
User input to logic (optical) and frame ground	250VAC continuous; 1500VAC for 1 minute
Group to group	Not applicable
Point to point	None
LED indicators	One LED per point shows individual point ON/OFF status OK LED indicates backplane power is present
Backplane current consumption	5V output: 55mA maximum
External power supply	None
Thermal derating	None
Input Characteristics	
Input voltage	0 to 264VAC (47 to 63Hz), 240VAC nominal
On state voltage	155 to 264VAC
Off state voltage	0 to 40VAC
On state current	7mA minimum
Off state current	1.5mA maximum
On response time	1 cycle maximum
Off response time	2 cycles maximum
Input impedance	38.5kOhms (reactive) at 60Hz, typical 46.3kOhms (reactive) at 50Hz, typical

IC200MDL141
Input Module, 240VAC 8 Points

Field Wiring

Terminal	Connection	Terminal	Connection
A1	Input 1	B1	No connection
A2	Input 2	B2	No connection
A3	Input 3	B3	No connection
A4	Input 4	B4	No connection
A5	Input 5	B5	No connection
A6	Input 6	B6	No connection
A7	Input 7	B7	No connection
A8	Input 8	B8	No connection
A9	No connection	B9	No connection
A10	No connection	B10	No connection
A11	No connection	B11	No connection
A12	No connection	B12	No connection
A13	No connection	B13	No connection
A14	No connection	B14	No connection
A15	No connection	B15	No connection
A16	No connection	B16	No connection
A17	Inputs 1-8 Common (Return)	B17	No connection
A18	No connection	B18	No connection

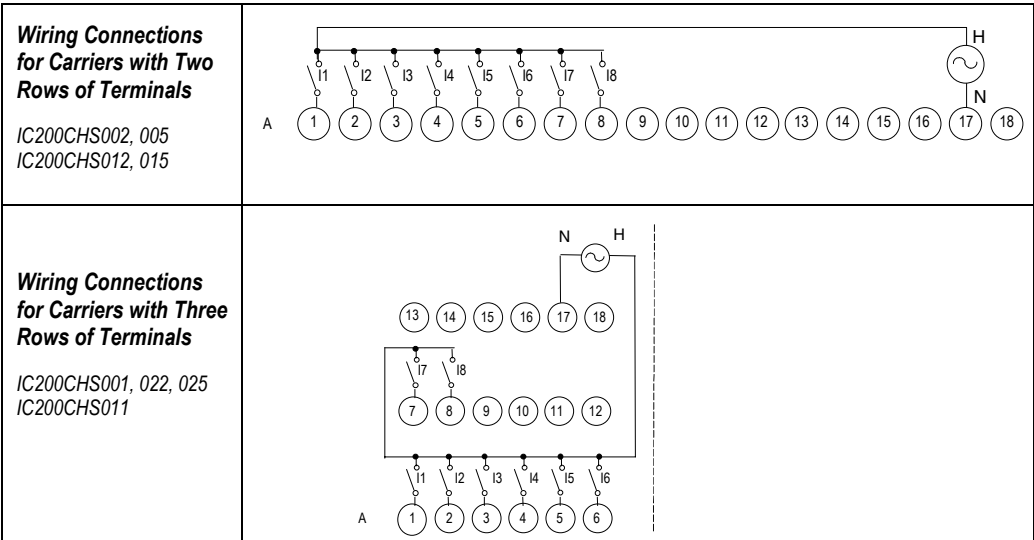

IC200MDL143 **Input Module, 120VAC Isolated 8 Points**

Discrete Input Module IC200MDL143 provides 8 isolated discrete inputs. Inputs are positive logic or sourcing-type inputs; they receive current from AC input devices and return the current on the common. Each input has its own return.

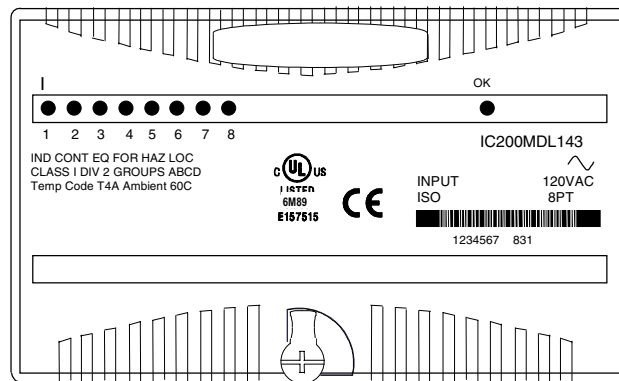

Power for module operation comes from the backplane.

Intelligent processing for the module is performed by the CPU or NIU. The module provides 8 bits of discrete input data.

LED Indicators

Individual green LEDs indicate the on/off state of each input point.

The green OK LED is on when backplane power is present to the module.

IC200MDL143
Input Module, 120VAC Isolated 8 Points

Module Specifications

Module Characteristics	
Points	8 Isolated Inputs
Module ID	FFFF8804
Isolation: User input to logic (optical) and frame ground Group to group Point to point	250VAC continuous; 1500VAC for 1 minute Not applicable 250VAC continuous; 1500VAC for 1 minute
LED indicators	One LED per point shows individual point ON/OFF status OK LED indicates backplane power is present
Backplane current consumption	5V output: 50mA maximum
External power supply	None
Thermal derating	None
Input Characteristics	
Input voltage	0 to 132VAC (47 to 63Hz), 120VAC nominal
On state voltage	70 to 132VAC
Off state voltage	0 to 20VAC
On state current	5mA minimum
Off state current	2.5mA maximum
On response time	1 cycle maximum
Off response time	2 cycles maximum
Input impedance	8.6kOhms (reactive) at 60Hz, typical 10.32kOhms (reactive) at 50Hz, typical

IC200MDL143
Input Module, 120VAC Isolated 8 Points

Field Wiring

Terminal	Connection	Terminal	Connection
A1	Input 1	B1	No connection
A2	Input 1 Return	B2	No connection
A3	Input 2	B3	No connection
A4	Input 2 Return	B4	No connection
A5	Input 3	B5	No connection
A6	Input 3 Return	B6	No connection
A7	Input 4	B7	No connection
A8	Input 4 Return	B8	No connection
A9	Input 5	B9	No connection
A10	Input 5 Return	B10	No connection
A11	Input 6	B11	No connection
A12	Input 6 Return	B12	No connection
A13	Input 7	B13	No connection
A14	Input 7 Return	B14	No connection
A15	Input 8	B15	No connection
A16	Input 8 Return	B16	No connection
A17	No connection	B17	No connection
A18	No connection	B18	No connection

Using a shorting bar with this module eliminates its point-to-point isolation characteristics.

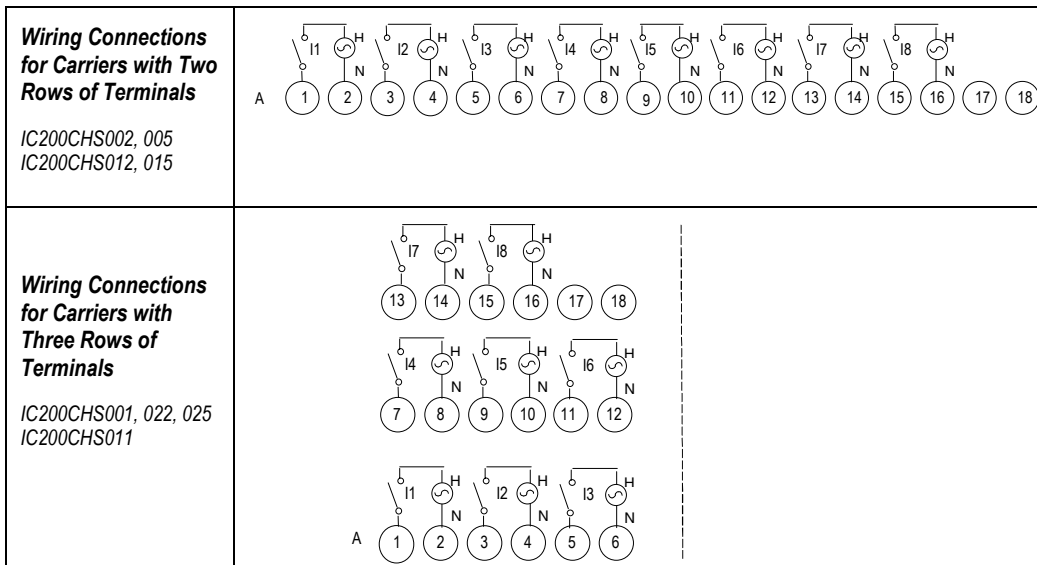

IC200MDL144
Input Module, 240VAC Isolated 4 Points

Discrete Input Module IC200MDL144 provides 4 isolated discrete inputs. Inputs are positive logic or sourcing-type inputs; they receive current from AC input devices and return the current on the common. Input devices are connected between the input terminals and common terminals.

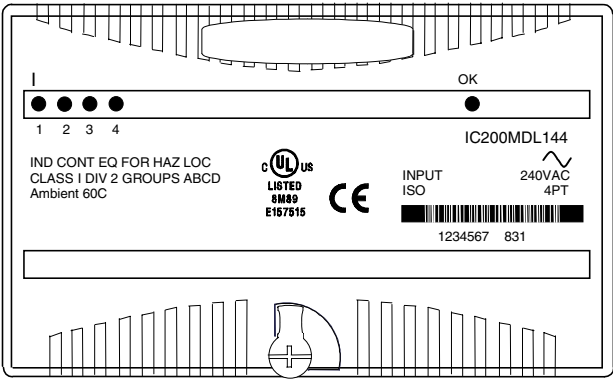

Power for module operation comes from the backplane.

Intelligent processing for the module is performed by the CPU or NIU. The module provides 4 bits of discrete input data.

LED Indicators

Individual green LEDs indicate the on/off state of each input point.

The green OK LED is on when backplane power is present to the module.

IC200MDL144
Input Module, 240VAC Isolated 4 Points

Module Specifications

Module Characteristics	
Points	4 Isolated Inputs
Module ID	FFFF8802
Isolation:	
User input to logic (optical) and frame ground	500VAC continuous; 2000VAC for 1 minute
Group to group	None
Point to point	500VAC continuous; 2000VAC for 1 minute
Carrier Requirement	Requires Box-Style, Barrier-Style or Spring-Style Carrier, revision B or later. Cannot be used with Connector-Style Carrier.
LED indicators	One LED per point shows individual point ON/OFF status OK LED indicates backplane power is present
Backplane current consumption	5V output: 30mA maximum
External power supply	None
Thermal derating	None
Input Characteristics	
Input voltage	0 to 264VAC (47 to 63Hz), 240VAC nominal
On state voltage	155 to 264VAC
Off state voltage	0 to 40VAC
On state current	7mA minimum
Off state current	1.5mA maximum
On response time	1 cycle maximum
Off response time	2 cycles maximum
Input impedance	38.5kOhms (reactive) at 60Hz, typical 46.3kOhms (reactive) at 50Hz, typical

IC200MDL144
Input Module, 240VAC Isolated 4 Points

Field Wiring

Terminal	Connection	Terminal	Connection
A1	No connection	B1	No connection
A2	No connection	B2	No connection
A3	Input 1	B3	No connection
A4	Input 1 Return	B4	No connection
A5	No connection	B5	No connection
A6	No connection	B6	No connection
A7	Input 2	B7	No connection
A8	Input 2 Return	B8	No connection
A9	No connection	B9	No connection
A10	No connection	B10	No connection
A11	Input 3	B11	No connection
A12	Input 3 Return	B12	No connection
A13	No connection	B13	No connection
A14	No connection	B14	No connection
A15	Input 4	B15	No connection
A16	Input 4 Return	B16	No connection
A17	No connection	B17	No connection
A18	No connection	B18	No connection

Using a shorting bar with this module eliminates its point-to-point isolation.

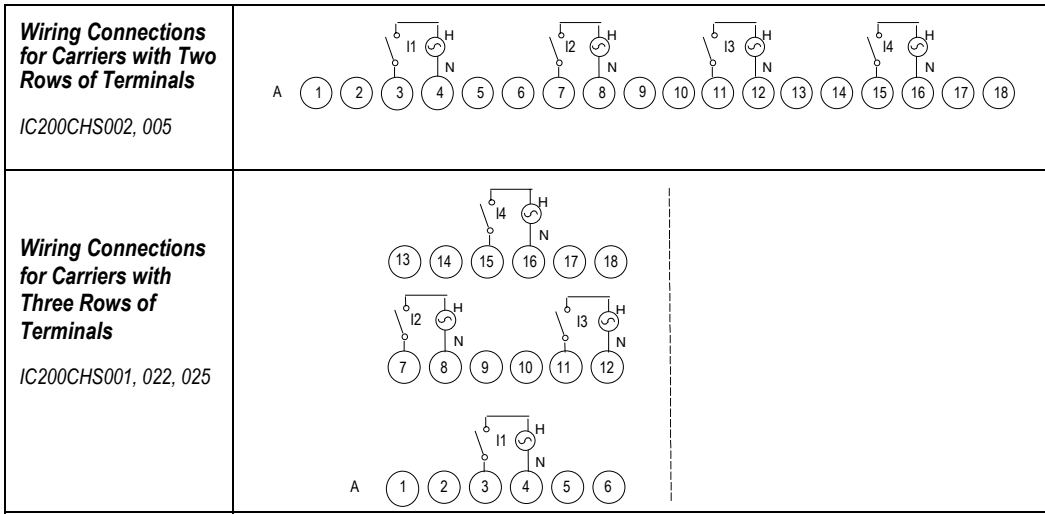

Discrete Input Module IC200MDL144 should be used with a compact terminal-style carrier (IC200CHS022 or 025) or with a terminal-style carrier (IC200CHS001, 002, 005 suffix “B” or higher). This module cannot be used with a Connector-Style Carrier (IC200CHS003) due to its high isolation requirement.

**IC200MDL240
Input Module, 120VAC 16 Points**

Discrete input module IC200MDL240 provides two groups of 8 discrete inputs each. Inputs are positive logic or sourcing-type inputs; they receive current from AC input devices and return the current on the common. Input devices are connected between the input terminals and common terminals.

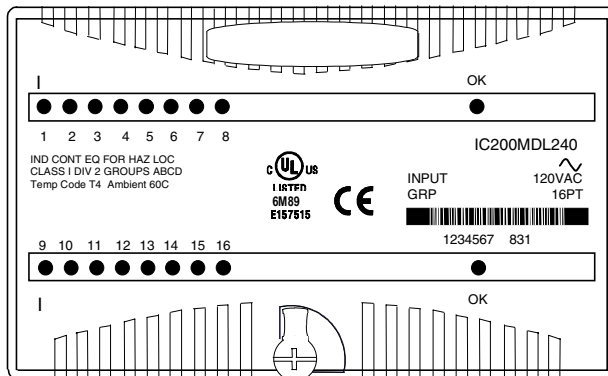

Power for module operation comes from the backplane.

Intelligent processing for the module is performed by the CPU or NIU. The module provides 16 bits of discrete input data.

LED Indicators

Individual green LEDs indicate the on/off state of each input point.

The green OK LED is on when backplane power is present to the module.

IC200MDL240
Input Module, 120VAC 16 Points

Module Specifications

Module Characteristics	
Points	Two groups of 8 inputs
Module ID	88048804
Isolation:	
User input to logic (optical) and frame ground	250VAC continuous; 1500VAC for 1 minute
Group to group	250VAC continuous; 1500VAC for 1 minute
Point to point	None
LED indicators	One LED per point shows individual point ON/OFF status OK LED indicates backplane power is present
Backplane current consumption	5V output: 110mA maximum
External power supply	None
Thermal derating	See diagram
Input Characteristics	
Input voltage	0 to 132VAC (47 to 63Hz), 120VAC nominal
On state voltage	70 to 132VAC
Off state voltage	0 to 20VAC
On state current	5mA minimum
Off state current	2.5mA maximum
On response time	1 cycle maximum
Off response time	2 cycles maximum
Input impedance	8.6kOhms (reactive) at 60Hz, typical 10.32kOhms (reactive) at 50Hz, typical

IC200MDL240
Input Module, 120VAC 16 Points

Field Wiring

Terminal	Connection	Terminal	Connection
A1	Input 1	B1	Input 9
A2	Input 2	B2	Input 10
A3	Input 3	B3	Input 11
A4	Input 4	B4	Input 12
A5	Input 5	B5	Input 13
A6	Input 6	B6	Input 14
A7	Input 7	B7	Input 15
A8	Input 8	B8	Input 16
A9	No connection	B9	No connection
A10	No connection	B10	No connection
A11	No connection	B11	No connection
A12	No connection	B12	No connection
A13	No connection	B13	No connection
A14	No connection	B14	No connection
A15	No connection	B15	No connection
A16	No connection	B16	No connection
A17	Inputs 1-8 Common (Return)	B17	Inputs 9-16 Common (Return)
A18	No connection	B18	No connection

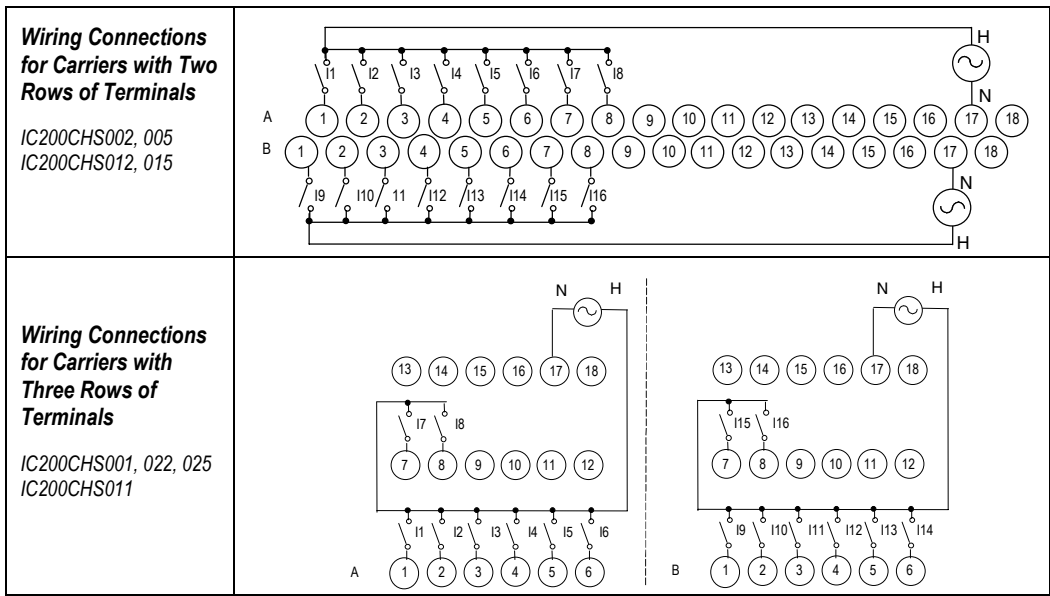

IC200MDL240
Input Module, 120VAC 16 Points

Thermal Derating

The number of points that can be on at the same time depends on the ambient temperature, the external voltage, and the orientation of the module and DIN rail.

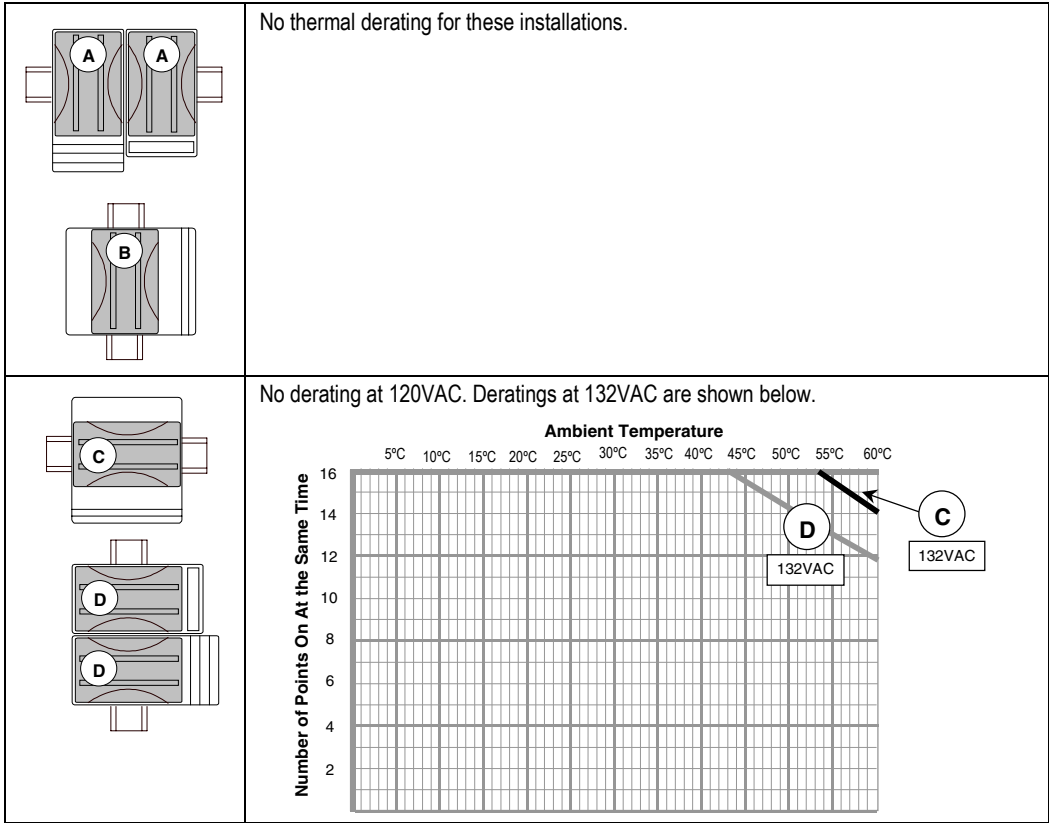

IC200MDL241 **Input Module, 240VAC16 Points**

Discrete Input Module IC200MDL241 provides two groups of 8 discrete inputs. Inputs are positive logic or sourcing-type inputs; they receive current from AC input devices and return the current on the common. Input devices are connected between the input terminals and common terminals.

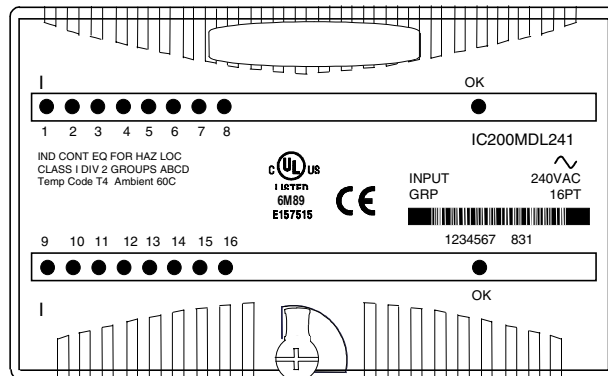

Power for module operation comes from the backplane.

Intelligent processing for the module is performed by the CPU or NIU. The module provides 16 bits of discrete input data.

LED Indicators

Individual green LEDs indicate the on/off state of each input point.

The green OK LED is on when backplane power is present to the module.

IC200MDL241
Input Module, 240VAC16 Points

Module Specifications

Module Characteristics	
Points	16 inputs (2 groups of 8)
Module ID	88048804
Isolation:	
User input to logic (optical) and frame ground	250VAC continuous; 1500VAC for 1 minute
Group to group	250VAC continuous; 1500VAC for 1 minute
Point to point	None
LED indicators	One LED per point shows individual point ON/OFF status OK LED indicates backplane power is present
Backplane current consumption	5V output: 110mA maximum
External power supply	None
Thermal derating	No derating when operated within the specified input voltage range
Input Characteristics	
Input voltage	0 to 264VAC (47 to 63Hz), 240VAC nominal
On state voltage	155 to 264VAC
Off state voltage	0 to 40VAC
On state current	7mA minimum
Off state current	1.5mA maximum
On response time	1 cycle maximum
Off response time	2 cycles maximum
Input impedance	38.5kOhms (reactive) at 60Hz, typical 46.3kOhms (reactive) at 50Hz, typical

IC200MDL241
Input Module, 240VAC16 Points

Field Wiring

Terminal	Connection	Terminal	Connection
A1	Input 1	B1	Input 9
A2	Input 2	B2	Input 10
A3	Input 3	B3	Input 11
A4	Input 4	B4	Input 12
A5	Input 5	B5	Input 13
A6	Input 6	B6	Input 14
A7	Input 7	B7	Input 15
A8	Input 8	B8	Input 16
A9	No connection	B9	No connection
A10	No connection	B10	No connection
A11	No connection	B11	No connection
A12	No connection	B12	No connection
A13	No connection	B13	No connection
A14	No connection	B14	No connection
A15	No connection	B15	No connection
A16	No connection	B16	No connection
A17	Inputs 1-8 Common (Return)	B17	Inputs 9-16 Common (Return)
A18	No connection	B18	No connection

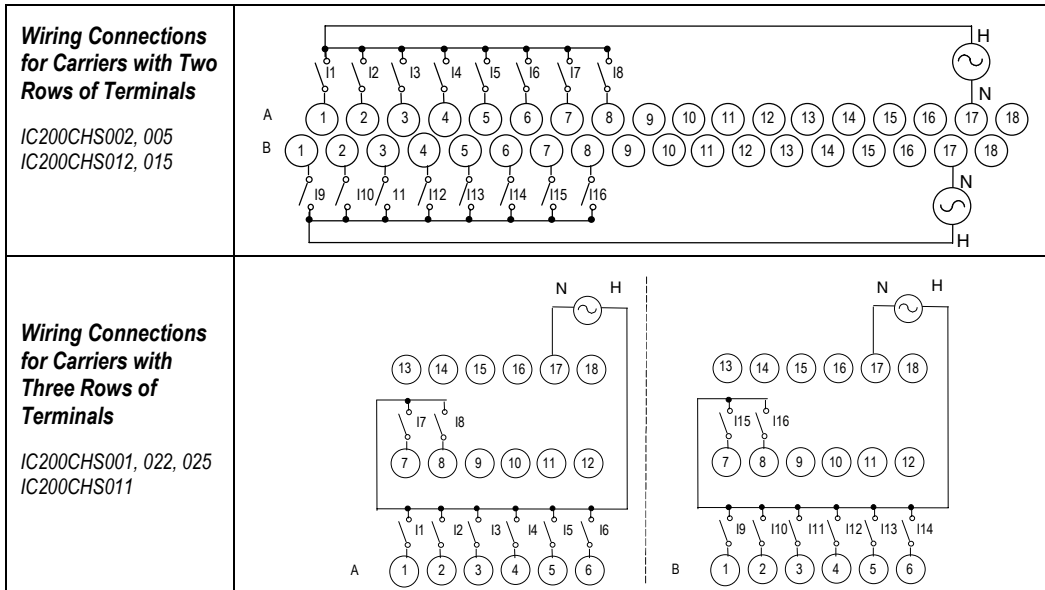

IC200MDL243
Input Module, 120VAC Isolated 16 Points

Discrete input module IC200MDL243 provides 16 isolated input points. Inputs are positive logic or sourcing-type inputs; they receive current from AC input devices and return the current on the common. Each input has its own return.

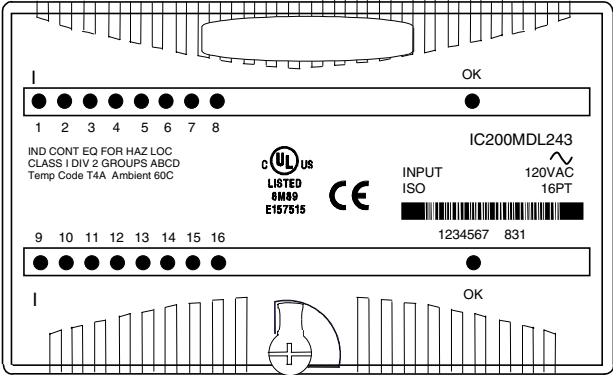

Power for module operation comes from the backplane.

Intelligent processing for the module is performed by the CPU or NIU. The module provides 16 bits of discrete input data.

LED Indicators

Individual green LEDs indicate the on/off state of each input point.

The green OK LED is on when backplane power is present to the module.

IC200MDL243
Input Module, 120VAC Isolated 16 Points

Module Specifications

Module Characteristics	
Points	16 Isolated Inputs
Module ID	88048804
Isolation:	
User input to logic (optical) and frame ground	250VAC continuous; 1500VAC for 1 minute
Group to group	Not applicable
Point to point	250VAC continuous; 1500VAC for 1 minute
LED indicators	One LED per point shows individual point ON/OFF status OK LED indicates backplane power is present
Backplane current consumption	5V output: 100mA maximum
External power supply	None
Thermal derating	See diagram
Input Characteristics	
Input voltage	0 to 132VAC (47 to 63Hz), 120VAC nominal
On state voltage	70 to 132VAC
Off state voltage	0 to 20VAC
On state current	5mA minimum
Off state current	2.5mA maximum
On response time	1 cycle maximum
Off response time	2 cycles maximum
Input impedance	8.6kOhms (reactive) at 60Hz, typical 10.32kOhms (reactive) at 50Hz, typical

IC200MDL243
Input Module, 120VAC Isolated 16 Points

Field Wiring

Terminal	Connection	Terminal	Connection
A1	Input 1	B1	Input 9
A2	Input 1 Return	B2	Input 9 Return
A3	Input 2	B3	Input 10
A4	Input 2 Return	B4	Input 10 Return
A5	Input 3	B5	Input 11
A6	Input 3 Return	B6	Input 11 Return
A7	Input 4	B7	Input 12
A8	Input 4 Return	B8	Input 12 Return
A9	Input 5	B9	Input 13
A10	Input 5 Return	B10	Input 13 Return
A11	Input 6	B11	Input 14
A12	Input 6 Return	B12	Input 14 Return
A13	Input 7	B13	Input 15
A14	Input 7 Return	B14	Input 15 Return
A15	Input 8	B15	Input 16
A16	Input 8 Return	B16	Input 16 Return
A17	No connection	B17	No connection
A18	No connection	B18	No connection

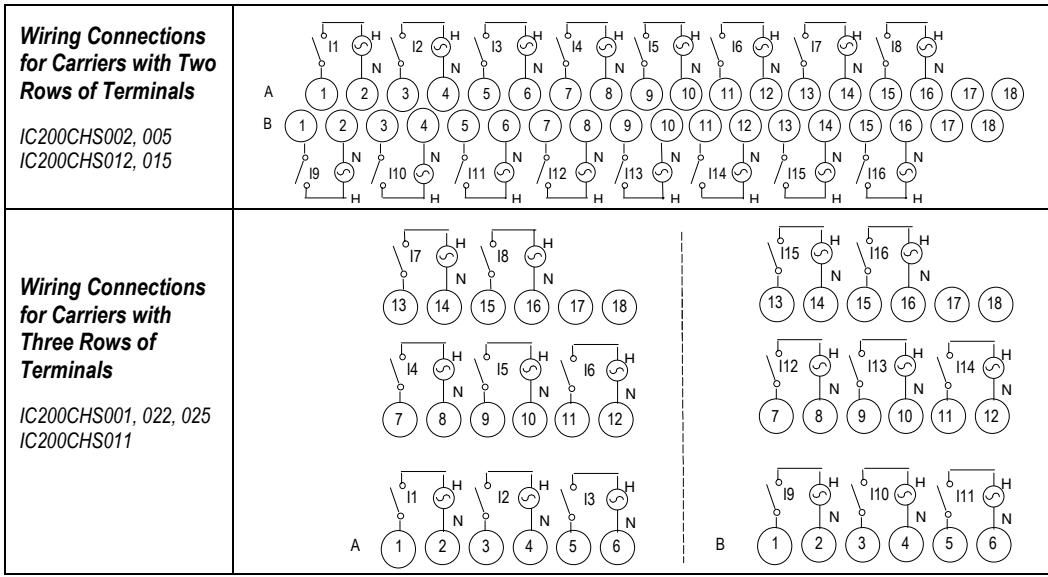

IC200MDL243
Input Module, 120VAC Isolated 16 Points

Thermal Derating

The number of points that can be on at the same time depends on the ambient temperature, the external voltage, and the orientation of the module and DIN rail.

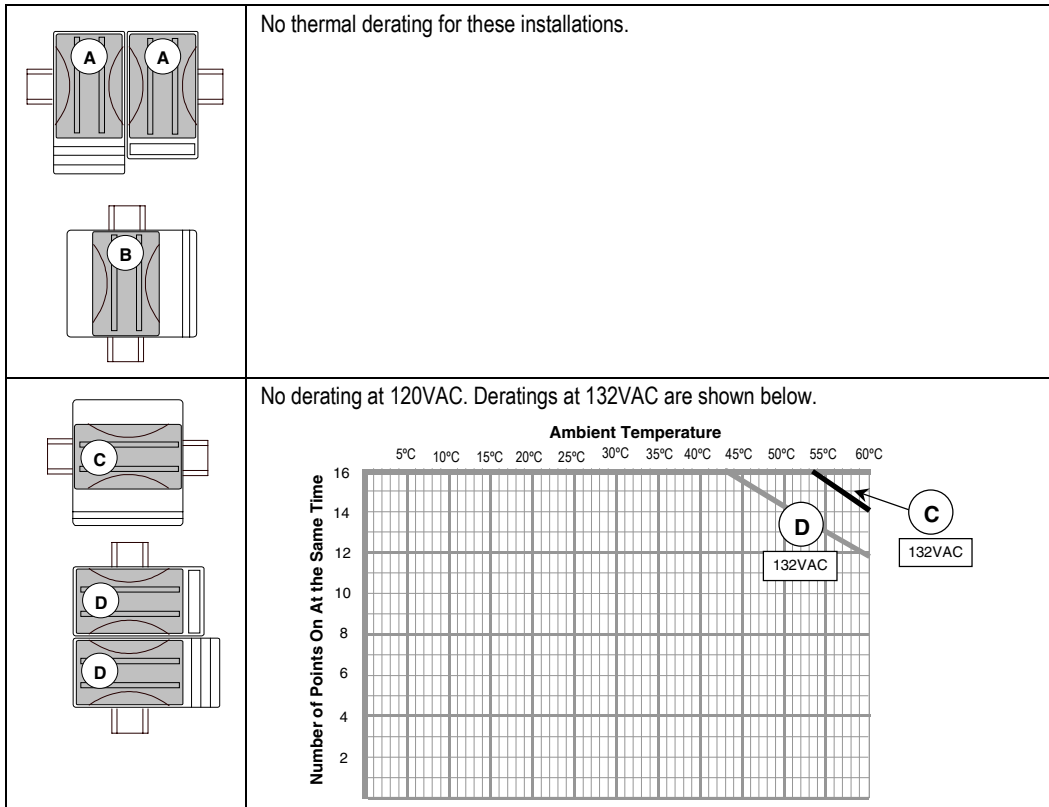

IC200MDL244
Input Module, 240VAC Isolated 8 Points

Discrete Input Module IC200MDL244 provides 8 isolated discrete inputs. Inputs are positive logic or sourcing-type inputs; they receive current from AC input devices and return the current on the common. Input devices are connected between the input terminals and common terminals.

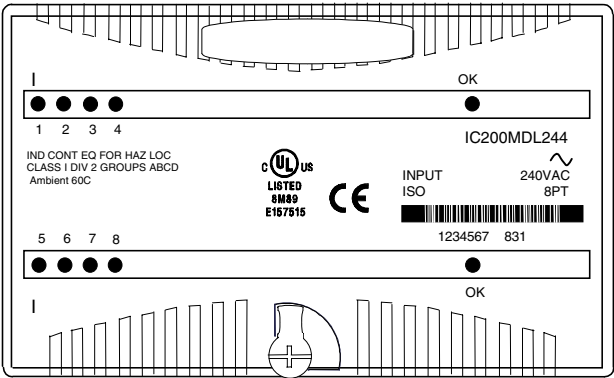

Power for module operation comes from the backplane.

Intelligent processing for the module is performed by the CPU or NIU. The module provides 8 bits of discrete input data (4 bits per card).

LED Indicators

Individual green LEDs indicate the on/off state of each input point.

The green OK LED is on when backplane power is present to the module.

IC200MDL244
Input Module, 240VAC Isolated 8 Points

Module Specifications

Module Characteristics	
Points	8 Isolated Inputs
Module ID	88028802
Isolation:	
User input to logic (optical) and frame ground	500VAC continuous; 2000VAC for 1 minute
Group to group	None
Point to point	500VAC continuous; 2000VAC for 1 minute
Carrier Requirement	Requires Box-Style, Barrier-Style or Spring-Style Carrier, revision B or later. Cannot be used with Connector-Style Carrier.
LED indicators	One LED per point shows individual point ON/OFF status OK LED indicates backplane power is present
Backplane current consumption	5V output: 60mA maximum
External power supply	None
Thermal derating	None
Input Characteristics	
Input voltage	0 to 264VAC (47 to 63Hz), 240VAC nominal
On state voltage	155 to 264VAC
Off state voltage	0 to 40VAC
On state current	7mA minimum
Off state current	1.5mA maximum
On response time	1 cycle maximum
Off response time	2 cycles maximum
Input impedance	38.5kOhms (reactive) at 60Hz, typical 46.3kOhms (reactive) at 50Hz, typical

IC200MDL244
Input Module, 240VAC Isolated 8 Points

Field Wiring

Terminal	Connection	Terminal	Connection
A1	No connection	B1	No connection
A2	No connection	B2	No connection
A3	Input 1	B3	Input 5
A4	Input 1 Return	B4	Input 5 Return
A5	No connection	B5	No connection
A6	No connection	B6	No connection
A7	Input 2	B7	Input 6
A8	Input 2 Return	B8	Input 6 Return
A9	No connection	B9	No connection
A10	No connection	B10	No connection
A11	Input 3	B11	Input 7
A12	Input 3 Return	B12	Input 7 Return
A13	No connection	B13	No connection
A14	No connection	B14	No connection
A15	Input 4	B15	Input 8
A16	Input 4 Return	B16	Input 8 Return
A17	No connection	B17	No connection
A18	No connection	B18	No connection

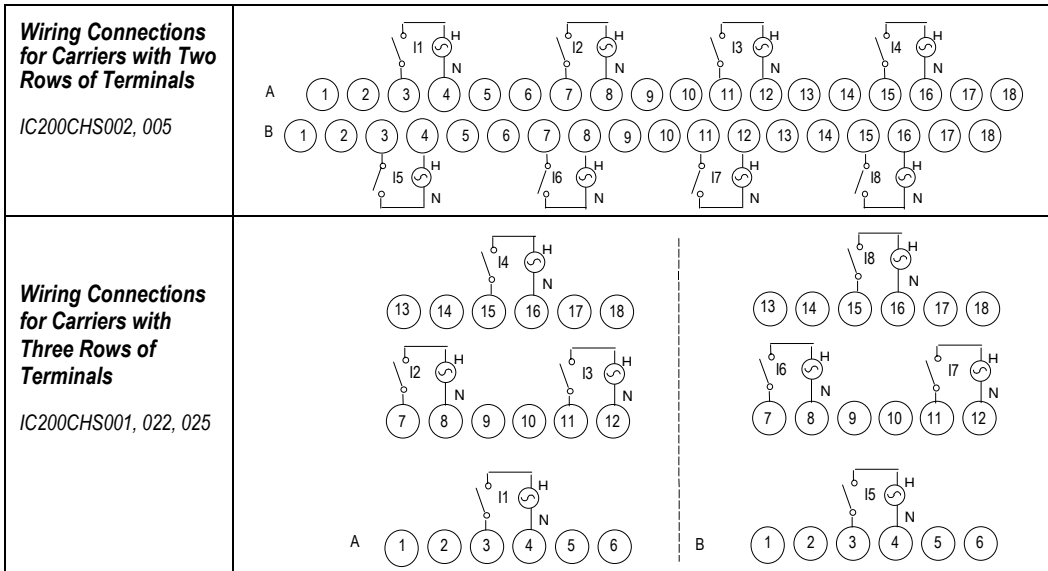

Module IC200MDL244 should be used with a compact terminal-style carrier (IC200CHS022 or 025) or with a terminal-style carrier (IC200CHS001, 002, 005 suffix “B” or higher). This module cannot be used with a Connector-Style Carrier (IC200CHS003) due to its high isolation requirement.

IC200MDL631 Input Module, 125VDC Pos/Neg Logic Isolated 8 Points

Discrete input module IC200MDL631 provides 8 discrete isolated inputs. Inputs can be either positive logic inputs that receive current from input devices and return the current on the return, or negative-logic inputs that receive current from the return and return current to the input device. Input devices are connected between the input terminals and return terminals.

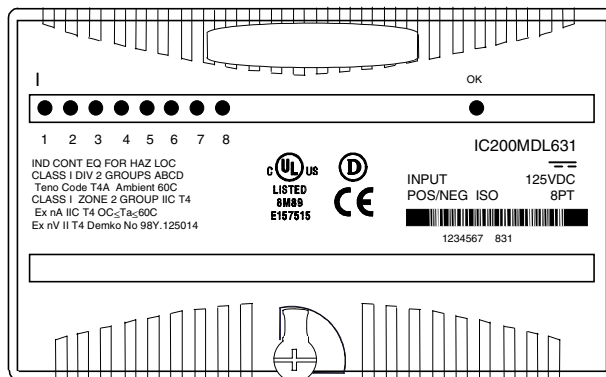

Power for module operation comes from the backplane.

Intelligent processing for this module is performed by the CPU or NIU. The module provides 8 bits of discrete input data.

LED Indicators

Individual green LEDs indicate the on/off state of each input point. Backplane power must be present for LEDs to provide status of inputs.

The green OK LED is on when backplane power is present to the module.

Configuration Parameters

The module's basic input on/off response time is 0.5 ms.

For some applications, it may be preferable to add additional filtering to compensate for conditions such as noise spikes or switch bounce. Input filter times of 0ms, 1.0ms, or 7.0ms are selectable via software configuration, for total response times of 0.5ms, 1.5ms, and 7.5ms respectively. The default is 1.0ms filter time (total response time is 1.5ms).

IC200MDL631**Input Module, 125VDC Pos/Neg Logic Isolated 8 Points****Module Specifications**

Module Characteristics	
Points	8 isolated inputs
Module ID	FFFF8004
Isolation: User input to logic (optical) and to frame ground Point to point	250VAC continuous; 1500VAC for 1 minute 250VAC continuous; 1500VAC for 1 minute
LED indicators	One LED per point shows individual point ON/OFF status OK LED indicates backplane power is present
Backplane current consumption	5V output: 40 mA maximum
External power supply	None
Thermal derating	No derating
Configuration parameters	Input response times
Input Characteristics	
Input voltage	0 to +150VDC, +125 VDC nominal
User input current	1.7mA typ. @ 125VDC, 2.2mA typ. @ 150VDC
Input impedance	74K Ohm typ. @ 125VDC
On state voltage	90VDC to 150VDC
Off state voltage	0VDC to 30VDC
On state current	1.0mA minimum
Off state current	0 to 0.1mA maximum
On response time	0.5ms maximum
Off response time	
Configurable filter time	0ms, 1.0ms (default), or 7.0ms

IC200MDL631
Input Module, 125VDC Pos/Neg Logic Isolated 8 Points

Field Wiring

Terminal	Connection	Terminal	Connection
A1	Input 1	B1	No connection
A2	Input 1 return	B2	No connection
A3	Input 2	B3	No connection
A4	Input 2 return	B4	No connection
A5	Input 3	B5	No connection
A6	Input 3 return	B6	No connection
A7	Input 4	B7	No connection
A8	Input 4 return	B8	No connection
A9	Input 5	B9	No connection
A10	Input 5 return	B10	No connection
A11	Input 6	B11	No connection
A12	Input 6 return	B12	No connection
A13	Input 7	B13	No connection
A14	Input 7 return	B14	No connection
A15	Input 8	B15	No connection
A16	Input 8 return	B16	No connection
A17	No connection	B17	No connection
A18	No connection	B18	No connection

Using a shorting bar with this module eliminates the point-to-point isolation.

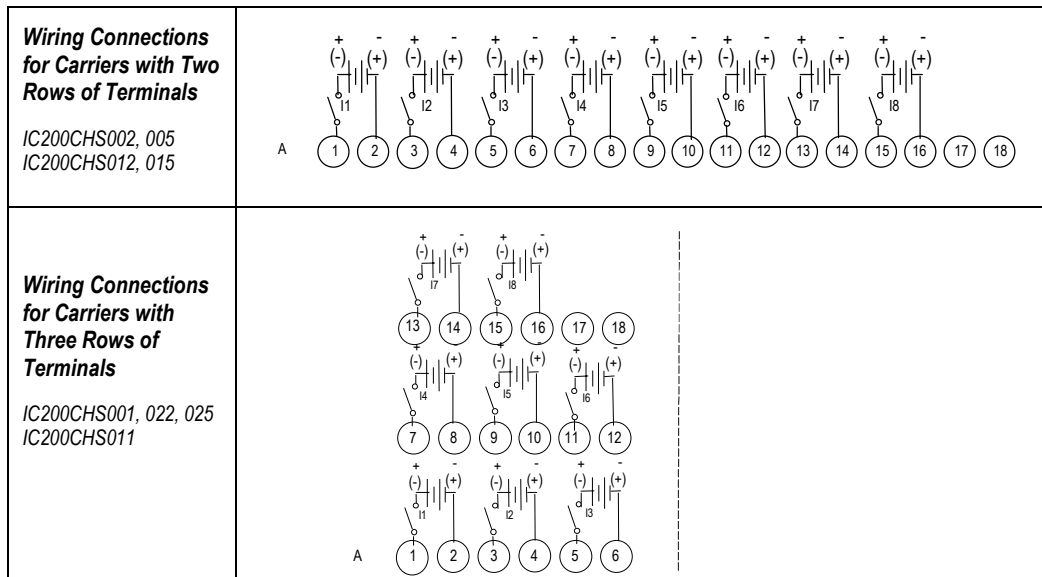

IC200MDL632

Input Module, 125VDC Pos/Neg Logic Isolated 16 Points

Discrete input module IC200MDL632 provides 16 discrete isolated inputs. Inputs can be either positive logic inputs that receive current from input devices and return the current on the return, or negative-logic inputs that receive current from the return and return current to the input device. Input devices are connected between the input terminals and return terminals.

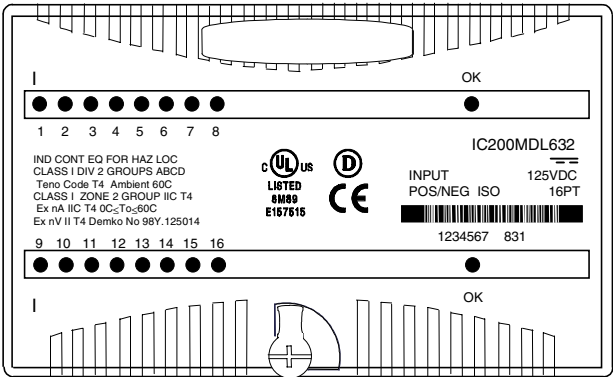

Power for module operation comes from the backplane.

Intelligent processing for this module is performed by the CPU or NIU. The module provides 16 bits of discrete input data.

LED Indicators

Individual green LEDs indicate the on/off state of each input point. Backplane power must be present for LEDs to provide status of inputs.

The green OK LED is on when backplane power is present to the module.

Configuration Parameters

The module’s basic input on/off response time is 0.5ms.

For some applications, it may be preferable to add additional filtering to compensate for conditions such as noise spikes or switch bounce. Input filter times of 0ms, 1.0ms, or 7.0ms are selectable via software configuration, for total response times of 0.5ms, 1.5ms, and 7.5ms respectively. The default is 1.0ms filter time (total response time is 1.5ms).

IC200MDL632
Input Module, 125VDC Pos/Neg Logic Isolated 16 Points

Module Specifications

Module Characteristics	
Points	16 isolated inputs
Module ID	80048004
Isolation: User input to logic (optical) and to frame ground Point to point	250VAC continuous; 1500VAC for 1 minute 250VAC continuous; 1500VAC for 1 minute
LED indicators	One LED per point shows individual point ON/OFF status OK LED indicates backplane power is present
Backplane current consumption	5V output: 80mA maximum
External power supply	None
Thermal derating	See diagram
Configuration parameters	Input response times
Input Characteristics	
Input voltage	0 to 150VDC, 125 VDC nominal
User input current	1.7mA typ. @ 125VDC, 2.2mA typ. @ 150VDC
Input impedance	74K Ohm typ. @ 125VDC
On state voltage	90VDC to 150VDC
Off state voltage	0 VDC to 30VDC
On state current	1.0mA minimum
Off state current	0 to 0.1mA maximum
On response time	0.5ms maximum
Off response time	
Configurable filter time	0 ms, 1.0ms (default), or 7.0ms

IC200MDL632
Input Module, 125VDC Pos/Neg Logic Isolated 16 Points

Field Wiring

Terminal	Connection	Terminal	Connection
A1	Input 1	B1	Input 9
A2	Input 1 return	B2	Input 9 return
A3	Input 2	B3	Input 10
A4	Input 2 return	B4	Input 10 return
A5	Input 3	B5	Input 11
A6	Input 3 return	B6	Input 11 return
A7	Input 4	B7	Input 12
A8	Input 4 return	B8	Input 12 return
A9	Input 5	B9	Input 13
A10	Input 5 return	B10	Input 13 return
A11	Input 6	B11	Input 14
A12	Input 6 return	B12	Input 14 return
A13	Input 7	B13	Input 15
A14	Input 7 return	B14	Input 15 return
A15	Input 8	B15	Input 16
A16	Input 8 return	B16	Input 16 return
A17	no connection	B17	no connection
A18	no connection	B18	no connection

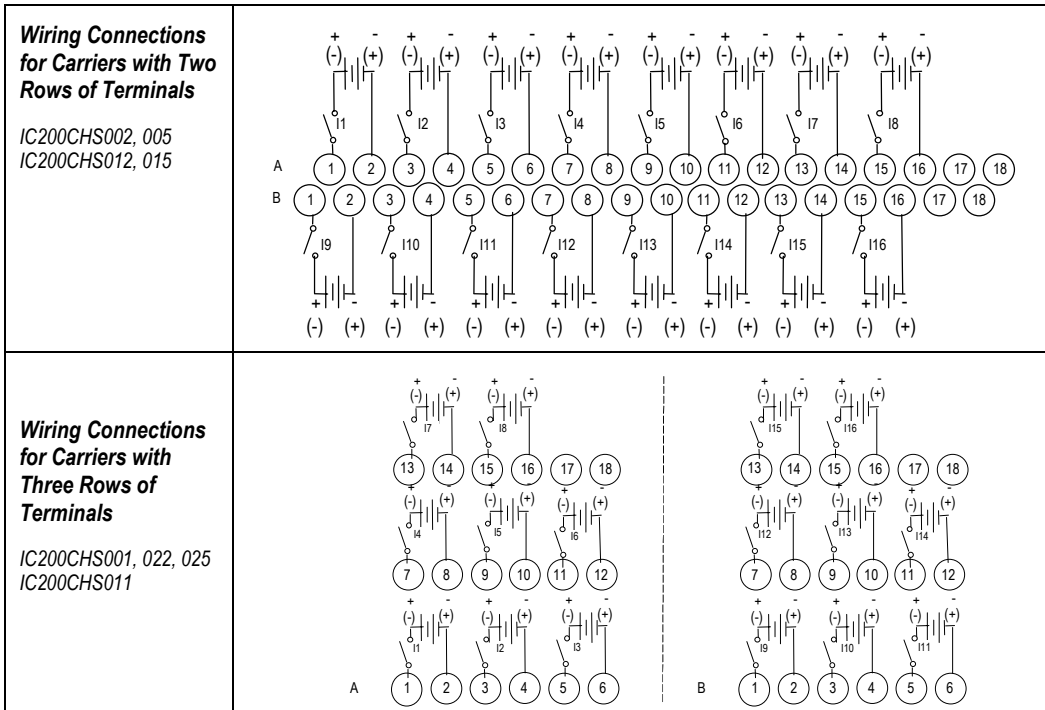

IC200MDL632
Input Module, 125VDC Pos/Neg Logic Isolated 16 Points

Thermal Derating

The number of points that can be on at the same time depends on the ambient temperature, the external voltage, and the orientation of the module and DIN rail.

There is no derating at 125VDC. Deratings at 150VDC are shown below.

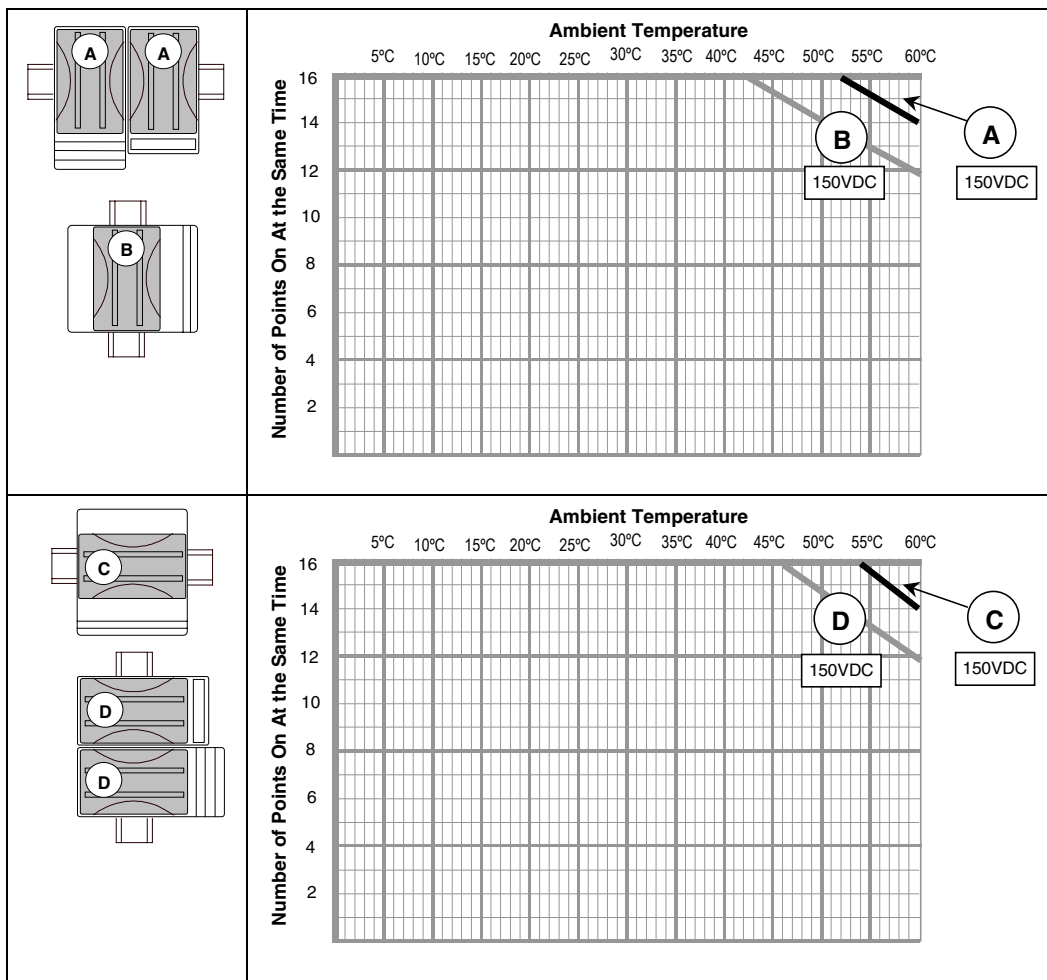

IC200MDL635

Input Module, 48VDC Pos/Neg Logic Grouped 16 Points

Discrete input module IC200MDL635 provides two groups of 8 discrete inputs. Inputs in each group can be either positive logic inputs that receive current from input devices and return the current on the common, or negative-logic inputs that receive current from the common and return current to the input device. Input devices are connected between the input terminals and common terminals.

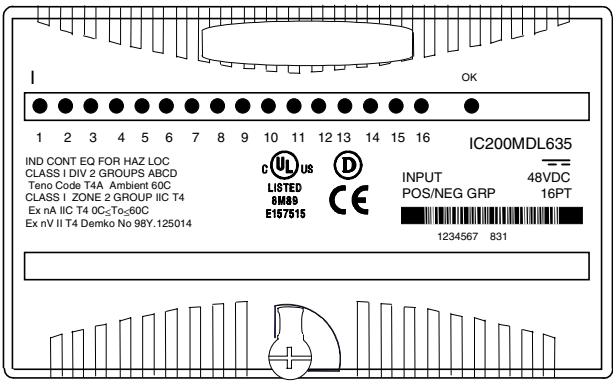

Power for module operation comes from the backplane.

Intelligent processing for this module is performed by the CPU or NIU. The module provides 16 bits of discrete input data.

LED Indicators

Individual green LEDs indicate the on/off state of each input point. Backplane power must be present for LEDs to provide status of inputs.

The green OK LED is on when backplane power is present to the module.

Configuration Parameters

The module’s basic input on/off response time is 0.5 ms.

For some applications, it may be preferable to add additional filtering to compensate for conditions such as noise spikes or switch bounce. Input filter times of 0ms, 1.0ms, or 7.0ms are selectable via software configuration, for total response times of 0.5ms, 1.5ms, and 7.5ms respectively. The default is 1.0ms filter time (total response time is 1.5ms).

IC200MDL635
Input Module, 48VDC Pos/Neg Logic Grouped 16 Points

Module Specifications

Module Characteristics	
Points	16 inputs (2 groups of 8)
Module ID	FFFF8008
Isolation:	
User input to logic (optical) and to frame ground	250VAC continuous; 1500VAC for 1 minute
Group to Group	250VAC continuous; 1500VAC for 1 minute
Point to point	None
LED indicators	One LED per point shows individual point ON/OFF status OK LED indicates backplane power is present
Backplane current consumption	5V output: 70 mA maximum
External power supply	None
Thermal derating	No derating
Configuration parameters	Input response times
Input Characteristics	
Input voltage	0 to 60VDC, 48 VDC nominal
User input current	1.7mA typ. @ 48VDC, 2.1mA typ. @ 60VDC
Input impedance	28K Ohm typ.
On state voltage	34VDC to 60VDC
Off state voltage	0 VDC to 10DC
On state current	1.0mA minimum
Off state current	0 to 0.4mA maximum
On response time	0.5ms maximum
Off response time	
Configurable filter time	0ms, 1.0ms (default), or 7.0ms

IC200MDL635
Input Module, 48VDC Pos/Neg Logic Grouped 16 Points

Field Wiring

Terminal	Connection	Terminal	Connection
A1	Input 1	B1	No connection
A2	Input 2	B2	No connection
A3	Input 3	B3	No connection
A4	Input 4	B4	No connection
A5	Input 5	B5	No connection
A6	Input 6	B6	No connection
A7	Input 7	B7	No connection
A8	Input 8	B8	No connection
A9	Input 9	B9	No connection
A10	Input 10	B10	No connection
A11	Input 11	B11	No connection
A12	Input 12	B12	No connection
A13	Input 13	B13	No connection
A14	Input 14	B14	No connection
A15	Input 15	B15	No connection
A16	Input 16	B16	No connection
A17	Inputs 1-8 Common	B17	No connection
A18	Inputs 9-16 Common	B18	No connection

The 16 inputs form two groups of 8. Each group has a common connection. Each group may be wired for positive or negative logic inputs. If additional bussed terminals are needed, the B terminals can be made available using a shorting bar. The shorting bar has a maximum current-carrying capacity of 2 Amps per point. See chapter 2 for additional information about using the shorting bar.

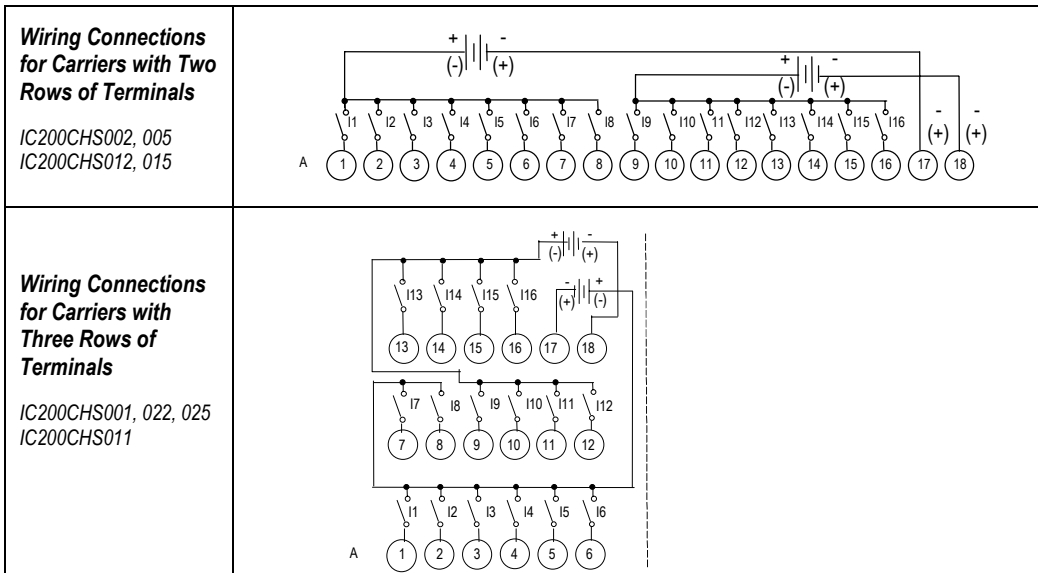

IC200MDL636
Input Module, 48VDC Pos/Neg Logic Grouped 32 Points

Discrete input module IC200MDL636 provides four groups of 8 discrete inputs. Inputs in each group can be either positive logic inputs that receive current from input devices and return the current on the common, or negative-logic inputs that receive current from the common and return current to the input device. Input devices are connected between the input terminals and common terminals.

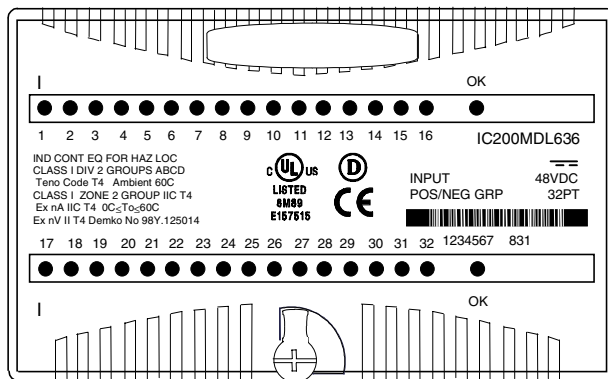

Power for module operation comes from the backplane.

Intelligent processing for this module is performed by the CPU or NIU. The module provides 32 bits of discrete input data.

LED Indicators

Individual green LEDs indicate the on/off state of each input point. Backplane power must be present for LEDs to provide status of inputs.

The green OK LED is on when backplane power is present to the module.

Configuration Parameters

The module's basic input on/off response time is 0.5ms.

For some applications, it may be preferable to add additional filtering to compensate for conditions such as noise spikes or switch bounce. Input filter times of 0ms, 1.0ms, or 7.0ms are selectable via software configuration, for total response times of 0.5ms, 1.5ms, and 7.5ms respectively. The default is 1.0ms filter time (total response time is 1.5ms).

IC200MDL636
Input Module, 48VDC Pos/Neg Logic Grouped 32 Points

Module Specifications

Module Characteristics	
Points	32 (4 groups of 8)
Module ID	80088008
Isolation:	
User input to logic (optical) and to frame ground	250VAC continuous; 1500VAC for 1 minute
Group to group	250VAC continuous; 1500VAC for 1 minute
Point to point	None
LED indicators	One LED per point shows individual point ON/OFF status OK LED indicates backplane power is present
Backplane current consumption	5V output: 140mA maximum
External power supply	None
Thermal derating	See diagram
Configuration parameters	Input response times
Input Characteristics	
Input voltage	0 to 60VDC, 48VDC nominal
User input current	1.7mA typ. @ 48VDC, 2.1mA typ. @ 60VDC
Input impedance	28K Ohm typ.
On state voltage	34VDC to 60VDC
Off state voltage	0 VDC to 10VDC
On state current	1.0mA minimum
Off state current	0 to 0.4mA maximum
On response time	0.5ms maximum
Off response time	
Configurable filter time	0 ms, 1.0ms (default), or 7.0ms

IC200MDL636
Input Module, 48VDC Pos/Neg Logic Grouped 32 Points

Field Wiring

Terminal	Connection	Terminal	Connection
A1	Input 1	B1	Input 17
A2	Input 2	B2	Input 18
A3	Input 3	B3	Input 19
A4	Input 4	B4	Input 20
A5	Input 5	B5	Input 21
A6	Input 6	B6	Input 22
A7	Input 7	B7	Input 23
A8	Input 8	B8	Input 24
A9	Input 9	B9	Input 25
A10	Input 10	B10	Input 26
A11	Input 11	B11	Input 27
A12	Input 12	B12	Input 28
A13	Input 13	B13	Input 29
A14	Input 14	B14	Input 30
A15	Input 15	B15	Input 31
A16	Input 16	B16	Input 32
A17	Inputs 1-8 Common	B17	Inputs 17-24 Common
A18	Inputs 9-16 Common	B18	Inputs 25-32 Common

The 32 inputs form four groups of 8. Each group has a common connection. Each group may be wired for positive or negative logic inputs.

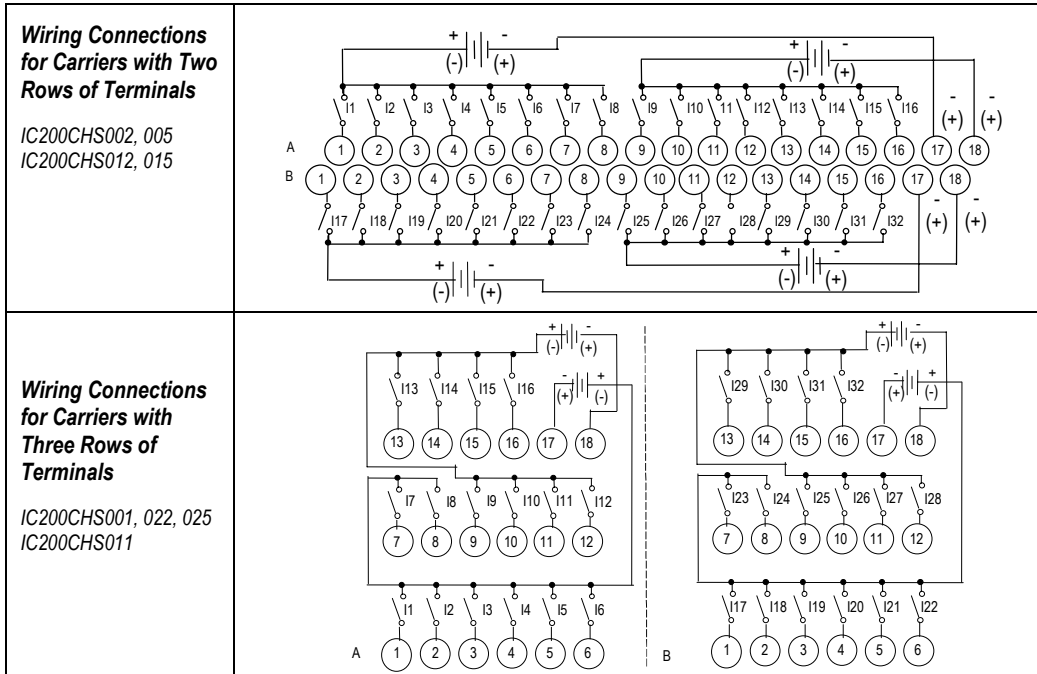

IC200MDL640 **Input Module, 24VDC Pos/Neg Logic 16 Points**

Discrete input module IC200MDL640 provides two groups of 8 discrete inputs. Inputs in each group can be either positive logic inputs that receive current from input devices and return the current on the common, or negative-logic inputs that receive current from the common and return current to the input device. Input devices are connected between the input terminals and common terminals.

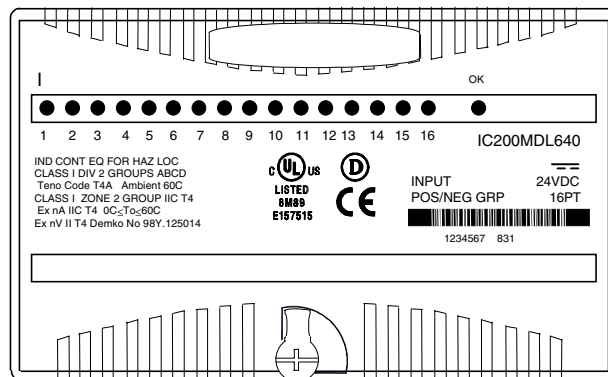

Note: Negative-logic functionality requires module version IC200MDL640C or higher.

Power for module operation comes from the backplane.

Intelligent processing for this module is performed by the CPU or NIU. The module provides 16 bits of discrete input data.

LED Indicators

Individual green LEDs indicate the on/off state of each input point.

The green OK LED is on when backplane power is present to the module.

Configuration Parameters

The module's basic input on/off response time is 0.5ms.

For some applications, it may be preferable to add additional filtering to compensate for conditions such as noise spikes or switch bounce. Input filter times of 0ms, 1.0ms, or 7.0ms are selectable via software configuration, for total response times of 0.5ms, 1.5ms, and 7.5ms respectively. The default is 1.0ms filter time (total response time is 1.5ms).

IC200MDL640
Input Module, 24VDC Pos/Neg Logic 16 Points

Module Specifications

Module Characteristics	
Points	16 inputs (2 groups of 8)
Module ID	FFFF8008
Isolation:	
User input to logic (optical) and to frame ground	250VAC continuous; 1500VAC for 1 minute
Group to Group	250VAC continuous; 1500VAC for 1 minute
Point to point	None
LED indicators	One LED per point shows individual point ON/OFF status OK LED indicates backplane power is present
Backplane current consumption	5V output: 25mA maximum
External power supply	None
Thermal derating	No derating
Configuration parameters	Input response times
Input Characteristics	
Input voltage	0 to +30VDC, +24VDC nominal
On state voltage	+15 to +30VDC
Off state voltage	0 to +5.0VDC
On state current	2.0 to 5.5mA
Off state current	0 to 0.5mA
On response time	0.5ms maximum
Off response time	
Configurable filter time	0ms, 1.0ms (default), or 7.0ms
Input impedance	10kOhms maximum

IC200MDL640
Input Module, 24VDC Pos/Neg Logic 16 Points

Field Wiring

Terminal	Connection	Terminal	Connection
A1	Input 1	B1	No connection
A2	Input 2	B2	No connection
A3	Input 3	B3	No connection
A4	Input 4	B4	No connection
A5	Input 5	B5	No connection
A6	Input 6	B6	No connection
A7	Input 7	B7	No connection
A8	Input 8	B8	No connection
A9	Input 9	B9	No connection
A10	Input 10	B10	No connection
A11	Input 11	B11	No connection
A12	Input 12	B12	No connection
A13	Input 13	B13	No connection
A14	Input 14	B14	No connection
A15	Input 15	B15	No connection
A16	Input 16	B16	No connection
A17	Inputs 1-8 Common	B17	No connection
A18	Inputs 9-16 Common	B18	No connection

The inputs form two groups of 8. Each group has a common connection. Each group may be wired for positive or negative logic inputs. Note: Negative-logic functionality requires version IC200MDL640C or higher. If additional bussed terminals are needed, the B terminals can be made available by using a shorting bar. The shorting bar has a maximum current-carrying capacity of 2 Amps per point. See chapter 2 for information about using the shorting bar.

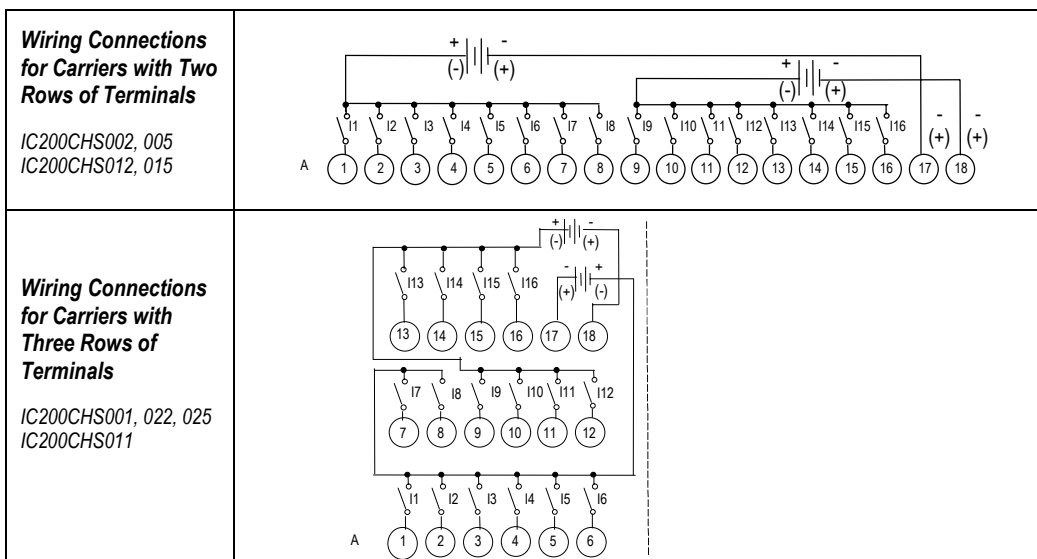

IC200MDL643

Input Module, 5/12VDC Pos/Neg Logic Grouped 16 Points

Discrete input module IC200MDL643 provides two groups of 8 discrete inputs. Inputs in each group can be either positive logic inputs that receive current from input devices and return the current on the common, or negative-logic inputs that receive current from the common and return current to the input device. Input devices are connected between the input terminals and common terminals. The module supports positive and negative logic inputs. For the inputs to be compatible with TTL devices, the negative logic configuration should be used.

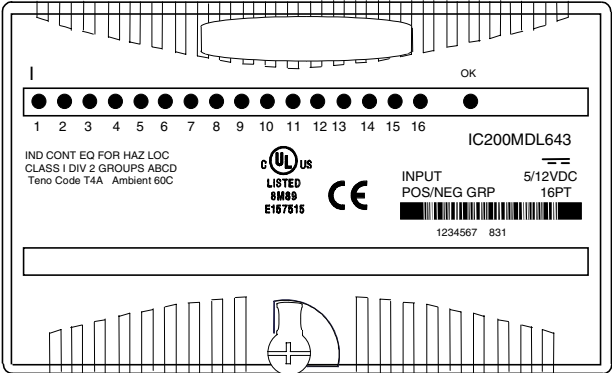

Power for module operation comes from the backplane. Intelligent processing for this module is performed by the CPU or NIU. The module provides 16 bits of discrete input data.

LED Indicators

Individual green LEDs indicate the on/off state of each input point. Backplane power must be present for LEDs to provide status of inputs. The green OK LED is on when backplane power is present to the module.

Configuration Parameters

The module’s basic input on/off response time is 0.25 ms. For some applications, it may be preferable to add additional filtering to compensate for conditions such as noise spikes or switch bounce. Input filter times of 0ms, 1.0ms, or 7.0ms are selectable via software configuration, for total response times of 0.25ms, 1.25ms, and 7.25ms respectively. The default is 1.0ms filter time (total response time is 1.25ms).

IC200MDL643
Input Module, 5/12VDC Pos/Neg Logic Grouped 16 Points

Module Specifications

Module Characteristics	
Points	16 inputs (2 groups of 8)
Module ID	FFFF8008
Isolation:	
User input to logic (optical) and to frame ground	250VAC continuous; 1500VAC for 1 minute
Group to Group	250VAC continuous; 1500VAC for 1 minute
Point to point	None
LED indicators	One LED per point shows individual point ON/OFF status OK LED indicates backplane power is present
Backplane current consumption	5V output: 70 mA maximum
External power supply	None
Thermal derating	No derating
Configuration parameters	Input response times
Input Characteristics	
Input voltage	0 to +15VDC, +5/12 VDC nominal
User input current	1.8mA typ. @ 5VDC, 4.9mA typ. @ 12VDC
Input impedance	2.4K Ohm typ. @ 12VDC
On state voltage	+4.2 to +15VDC
Off state voltage	0 to +2.6VDC
On state current	1.45mA minimum
Off state current	0 to 0.7mA maximum
On response time	0.25ms maximum
Off response time	
Configurable filter time	0ms, 1.0ms (default), or 7.0ms

IC200MDL643
Input Module, 5/12VDC Pos/Neg Logic Grouped 16 Points

Field Wiring

Terminal	Connection	Terminal	Connection
A1	Input 1	B1	No connection
A2	Input 2	B2	No connection
A3	Input 3	B3	No connection
A4	Input 4	B4	No connection
A5	Input 5	B5	No connection
A6	Input 6	B6	No connection
A7	Input 7	B7	No connection
A8	Input 8	B8	No connection
A9	Input 9	B9	No connection
A10	Input 10	B10	No connection
A11	Input 11	B11	No connection
A12	Input 12	B12	No connection
A13	Input 13	B13	No connection
A14	Input 14	B14	No connection
A15	Input 15	B15	No connection
A16	Input 16	B16	No connection
A17	Inputs 1-8 Common	B17	No connection
A18	Inputs 9-16 Common	B18	No connection

The 16 inputs form two groups of 8. Each group has a common connection. Each group may be wired for positive or negative logic inputs. If additional bussed terminals are needed, the B terminals can be made available by using a shorting bar. The shorting bar has a maximum current-carrying capacity of 2 Amps per point. See chapter 2 for information about using the shorting bar.

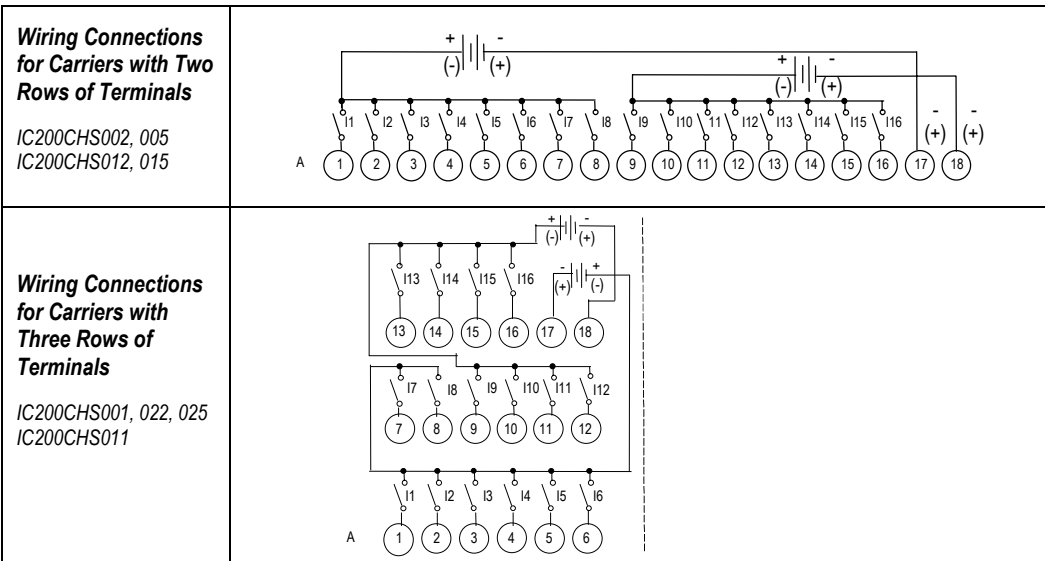

IC200MDL643
Input Module, 5/12VDC Pos/Neg Logic Grouped 16 Points

Wiring for TTL Inputs

To be compatible with TTL outputs, the negative logic configuration should be used as shown below.

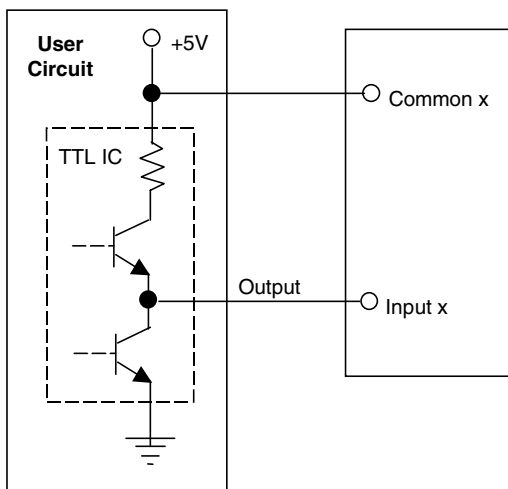

IC200MDL644

Input Module, 5/12VDC Pos/Neg Logic Grouped 32 Point

Discrete input module IC200MDL644 provides four groups of 8 discrete inputs. Inputs in each group can be either positive logic inputs that receive current from input devices and return the current on the common, or negative-logic inputs that receive current from the common and return current to the input device. Input devices are connected between the input terminals and common terminals. The module supports positive and negative logic inputs. For the inputs to be compatible with TTL devices, the negative logic configuration should be used.

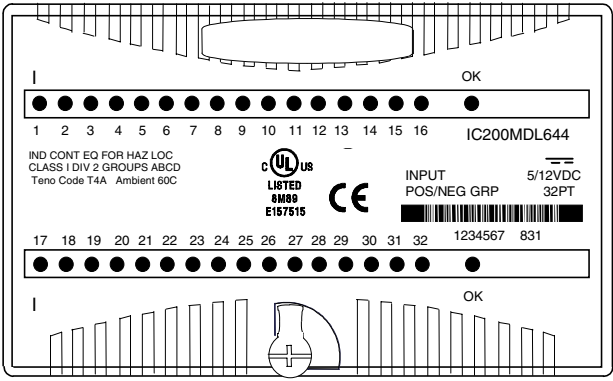

Power for module operation comes from the backplane. Intelligent processing for this module is performed by the CPU or NIU. The module provides 32 bits of discrete input data.

LED Indicators

Individual green LEDs indicate the on/off state of each input point. Backplane power must be present for LEDs to provide status of inputs. The green OK LED is on when backplane power is present to the module.

Configuration Parameters

The module's basic input on/off response time is 0.25ms. For some applications, it may be preferable to add additional filtering to compensate for conditions such as noise spikes or switch bounce. Input filter times of 0ms, 1.0ms, or 7.0ms are selectable via software configuration, for total response times of 0.25ms, 1.25ms, and 7.25ms respectively. The default is 1.0ms filter time (total response time is 1.25ms).

IC200MDL644
Input Module, 5/12VDC Pos/Neg Logic Grouped 32 Point

Module Specifications

Module Characteristics	
Points	32 (4 groups of 8)
Module ID	80088008
Isolation: User input to logic (optical) and to frame ground Group to group Point to point	250VAC continuous; 1500VAC for 1 minute 250VAC continuous; 1500VAC for 1 minute None
LED indicators	One LED per point shows individual point ON/OFF status OK LED indicates backplane power is present
Backplane current consumption	5V output: 140mA maximum
External power supply	None
Thermal derating	No derating
Configuration parameters	Input response times
Input Characteristics	
Input voltage	0 to +15VDC, +5/12 VDC nominal
User input current	1.8mA typ. @ 5VDC, 4.9mA typ. @ 12VDC
Input impedance	2.4K Ohm typ. @ 12VDC
On state voltage	+4.2 to +15VDC
Off state voltage	0 to +2.6VDC
On state current	1.45mA minimum
Off state current	0 to 0.7mA maximum
On response time	0.25ms maximum
Off response time	
Configurable filter time	0 ms, 1.0ms (default), or 7.0ms

IC200MDL644
Input Module, 5/12VDC Pos/Neg Logic Grouped 32 Point

Field Wiring

Terminal	Connection	Terminal	Connection
A1	Input 1	B1	Input 17
A2	Input 2	B2	Input 18
A3	Input 3	B3	Input 19
A4	Input 4	B4	Input 20
A5	Input 5	B5	Input 21
A6	Input 6	B6	Input 22
A7	Input 7	B7	Input 23
A8	Input 8	B8	Input 24
A9	Input 9	B9	Input 25
A10	Input 10	B10	Input 26
A11	Input 11	B11	Input 27
A12	Input 12	B12	Input 28
A13	Input 13	B13	Input 29
A14	Input 14	B14	Input 30
A15	Input 15	B15	Input 31
A16	Input 16	B16	Input 32
A17	Inputs 1-8 Common	B17	Inputs 17-24 Common
A18	Inputs 9-16 Common	B18	Inputs 25-32 Common

The 32 inputs form four groups of 8. Each group has a common connection. Each group may be wired for positive or negative logic inputs.

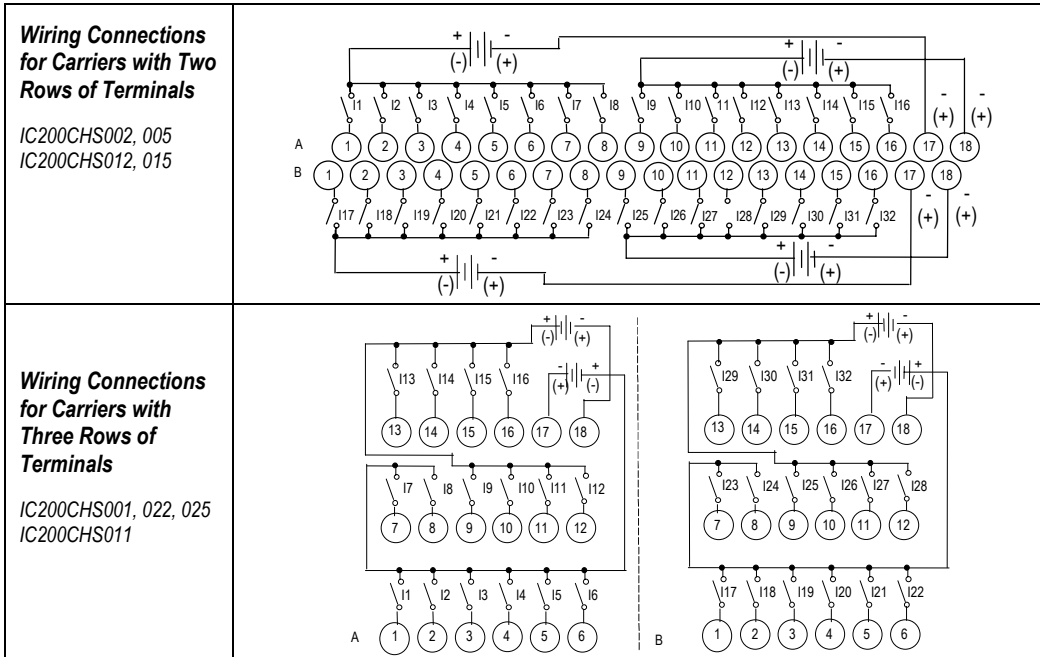

IC200MDL644
Input Module, 5/12VDC Pos/Neg Logic Grouped 32 Point

Wiring for TTL Inputs

To be compatible with TTL outputs, the negative logic configuration should be used as shown below.

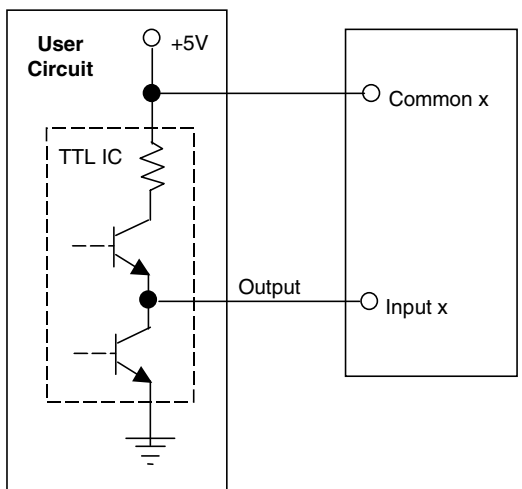

IC200MDL650
Input Module, 24VDC Pos/Neg Logic 32 Points

Discrete input module IC200MDL650 provides four groups of 8 discrete inputs. Inputs in each group can be either positive logic inputs that receive current from input devices and return the current on the common, or negative-logic inputs that receive current from the common and return current to the input device. Input devices are connected between the input terminals and common terminals.

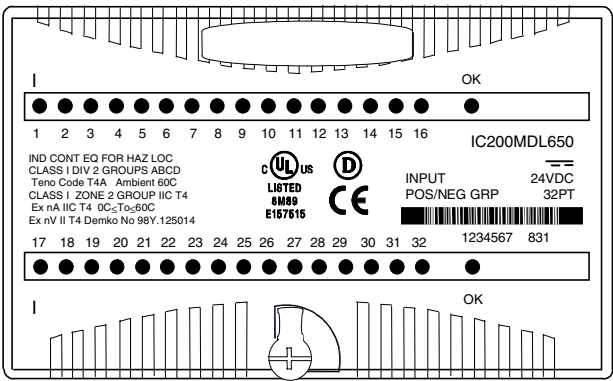

Note: Negative-logic functionality requires module version IC200MDL650C or higher.

Power for module operation comes from the backplane.

Intelligent processing for this module is performed by the CPU or NIU. The module provides 32 bits of discrete input data.

LED Indicators

Individual green LEDs indicate the on/off state of each input point.

The green OK LED is on when backplane power is present to the module.

Configuration Parameters

The module’s basic input on/off response time is 0.5ms.

For some applications, it may be preferable to add additional filtering to compensate for conditions such as noise spikes or switch bounce. Input filter times of 0ms, 1.0ms, or 7.0ms are selectable via CPU software configuration, for total response times of 0.5ms, 1.5ms, and 7.5ms respectively. The default is 1.0ms filter time (total response time is 1.5ms).

IC200MDL650
Input Module, 24VDC Pos/Neg Logic 32 Points

Module Specifications

Module Characteristics	
Points	32 (4 groups of 8)
Module ID	80088008
Isolation: User input to logic (optical) and to frame ground Group to group Point to point	250VAC continuous; 1500VAC for 1 minute 250VAC continuous; 1500VAC for 1 minute None
LED indicators	One LED per point shows individual point ON/OFF status OK LED indicates backplane power is present
Backplane current consumption	5V output: 50mA maximum
External power supply	None
Thermal derating	See diagram
Configuration parameters	Input response times
Input Characteristics	
Input voltage	0 to +30VDC, +24VDC nominal
On state voltage	+15 to +30VDC
Off state voltage	0 to +5VDC
On state current Off state current	2.0 to 5.5mA 0 to 0.5mA
On response time Off response time	0.5ms maximum
Configurable filter time	0 ms, 1.0ms (default), or 7.0ms
Input impedance	10kOhms maximum

IC200MDL650
Input Module, 24VDC Pos/Neg Logic 32 Points

Field Wiring

Terminal	Connection	Terminal	Connection
A1	Input 1	B1	Input 17
A2	Input 2	B2	Input 18
A3	Input 3	B3	Input 19
A4	Input 4	B4	Input 20
A5	Input 5	B5	Input 21
A6	Input 6	B6	Input 22
A7	Input 7	B7	Input 23
A8	Input 8	B8	Input 24
A9	Input 9	B9	Input 25
A10	Input 10	B10	Input 26
A11	Input 11	B11	Input 27
A12	Input 12	B12	Input 28
A13	Input 13	B13	Input 29
A14	Input 14	B14	Input 30
A15	Input 15	B15	Input 31
A16	Input 16	B16	Input 32
A17	Inputs 1-8 Common	B17	Inputs 17-24 Common
A18	Inputs 9-16 Common	B18	Inputs 25-32 Common

The 32 inputs form four groups of 8. Each group has a common connection. Each group may be wired for positive or negative logic inputs. Note: Negative-logic functionality requires version IC200MDL650C or higher.

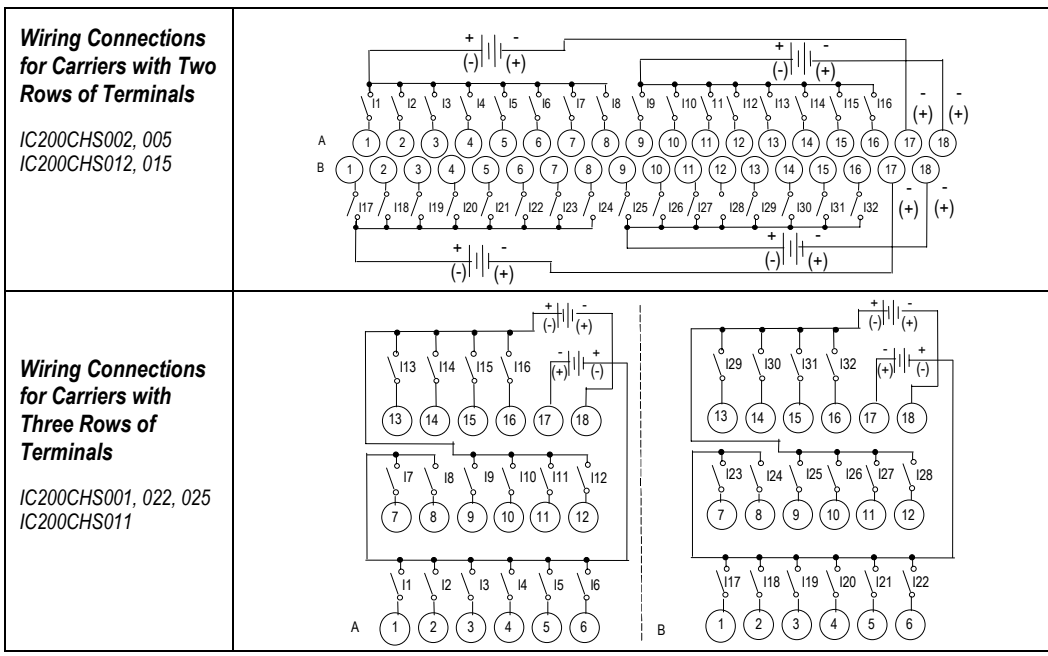

IC200MDL650
Input Module, 24VDC Pos/Neg Logic 32 Points

Thermal Derating

The number of points that can be on at the same time depends on the ambient temperature, the external voltage, and the orientation of the module and DIN rail.

There is no derating at 24VDC. Deratings at 30VDC are shown below.

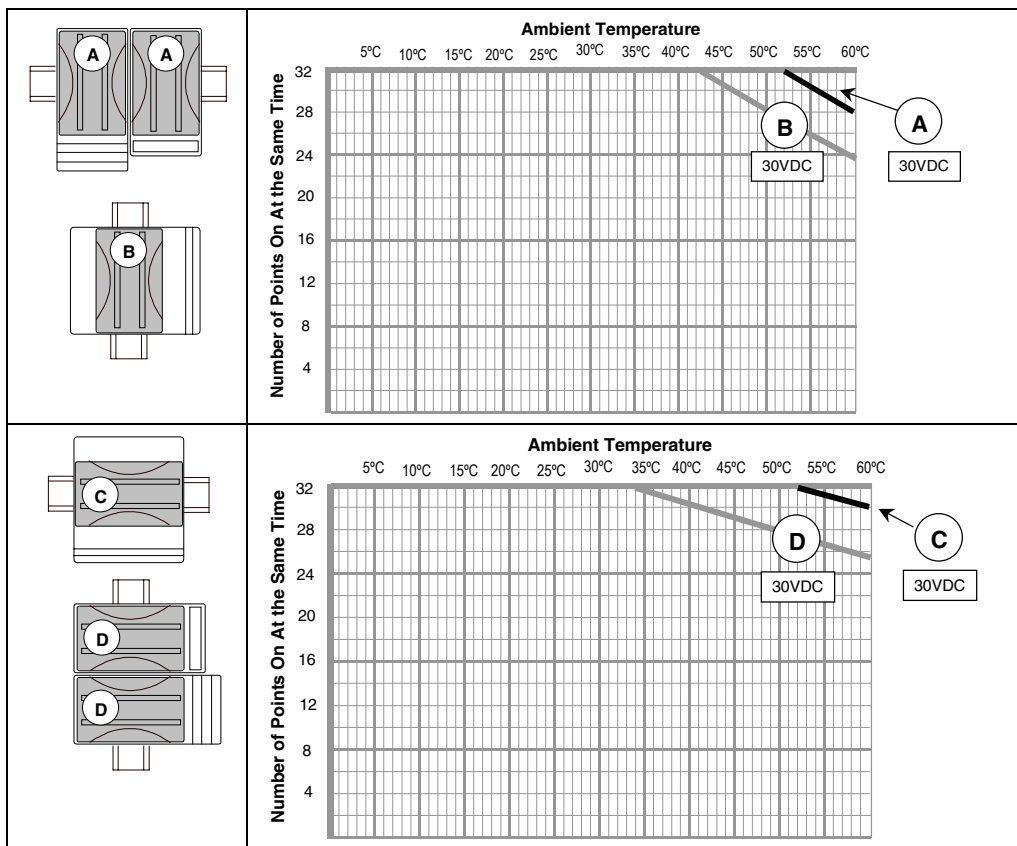

Chapter 8

Discrete Output Modules

This chapter describes VersaMax discrete output modules.

- | | |
|---------------|---|
| ▪ IC200MDL329 | Output Module, 120VAC 0.5 Amp, Isolated 8 Points |
| ▪ IC200MDL330 | Output Module, 120VAC 0.5 Amp, Isolated 16 Points |
| ▪ IC200MDL331 | Output Module, 120VAC 2.0 Amp, Isolated 8 Points |
| ▪ IC200MDL730 | Output Module, 24VDC Positive Logic 2.0 Amps, w/ESCP 8 Points |
| ▪ IC200MDL740 | Output Module, 12/24VDC Positive Logic 0.5 Amp, 16 Points |
| ▪ IC200MDL741 | Output Module, 24VDC Positive Logic 0.5 Amp, w/ESCP 16 Points |
| ▪ IC200MDL742 | Output Module, 24VDC Positive Logic 0.5 Amp, w/ESCP 32 Points |
| ▪ IC200MDL743 | Output Module, 5/12/24V DC Negative Logic 0.5 Amp, 16 Points |
| ▪ IC200MDL744 | Output Module, 5/12/24VDC Negative Logic 0.5 Amp, 32 Points |
| ▪ IC200MDL750 | Output Module, 12/24VDC Positive Logic 0.5 Amp, 32 Points |
| ▪ IC200MDL930 | Output Module, Relay 2.0 Amp Isolated Form A 8 Points |
| ▪ IC200MDL940 | Output Module, Relay 2.0 Amp, Isolated Form A 16 Points |

IC200MDL329 Output Module, 120VAC 0.5 Amp, Isolated 8 Points

Discrete output module IC200MDL329 provides 8 isolated outputs.

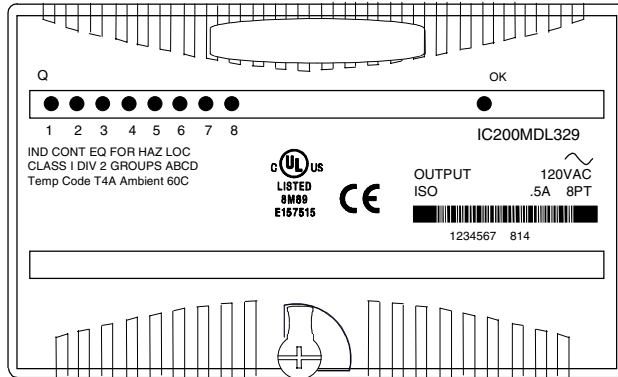

An external 120 VAC power supply must be provided to switch power to the loads.

Intelligent processing for this module is performed by the CPU or NIU. The module receives 8 bits of discrete output data.

LED Indicators

Individual green LEDs indicate the on/off state of the output points. The output LEDs are logic-driven and independent of the load conditions.

The green OK LED is on when backplane power is present to the module.

IC200MDL329
Output Module, 120VAC 0.5 Amp, Isolated 8 Points

Module Specifications

Module Characteristics	
Points	8 isolated outputs
Module ID	FFFF8840
Isolation:	
User input to logic (optical) and to frame ground	250VAC continuous; 1500VAC for 1 minute
Group to group	Not applicable
Point to point	250VAC continuous; 1500VAC for 1 minute
LED indicators	One LED per point shows individual point on/off state OK LED indicates backplane power is present
Backplane current consumption	5V output: 70mA maximum
External power supply	85 to 132VAC (47 to 63Hz), 120VAC nominal
Thermal derating	See Diagram
Output Characteristics	
Output voltage	85 to 132 VAC (47 to 63Hz), 120VAC nominal
Output voltage drop	2.0V maximum
Load current	10mA minimum per point 0.5A maximum per point 5.0A for one cycle (20ms) maximum inrush
Output leakage current	Less than 2mA at 132VAC
On response time	Less than ½ cycle, maximum
Off response time	Less than ½ cycle, maximum
Protection	Snubber and MOVs (each output)
Diagnostics	None

IC200MDL329
Output Module, 120VAC 0.5 Amp, Isolated 8 Points

Field Wiring

Terminal	Connection	Terminal	Connection
A1	Output 1	B1	No connection
A2	Output 1 Ret	B2	No connection
A3	Output 2	B3	No connection
A4	Output 2 Ret	B4	No connection
A5	Output 3	B5	No connection
A6	Output 3 Ret	B6	No connection
A7	Output 4	B7	No connection
A8	Output 4 Ret	B8	No connection
A9	Output 5	B9	No connection
A10	Output 5 Ret	B10	No connection
A11	Output 6	B11	No connection
A12	Output 6 Ret	B12	No connection
A13	Output 7	B13	No connection
A14	Output 7 Ret	B14	No connection
A15	Output 8	B15	No connection
A16	Output 8 Ret	B16	No connection
A17	No connection	B17	No connection
A18	No connection	B18	No connection

If additional bussed terminals are needed, the B terminals can be made available by using a shorting bar. The shorting bar has a maximum current-carrying capacity of 2A per point. See chapter 2 for additional information about using the shorting bar.

When wiring outputs to inductive loads, use of external suppression circuits is recommended. See chapter 2, "Installing Wiring for I/O Devices-Wiring to Inductive Loads" for more information.

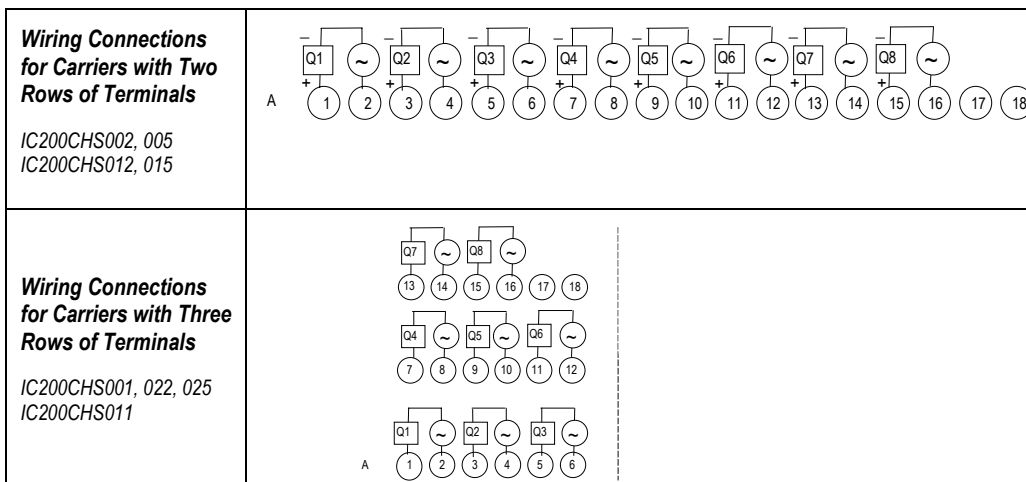

IC200MDL329
Output Module, 120VAC 0.5 Amp, Isolated 8 Points

Thermal Derating

The number of points that can be on at the same time depends on the ambient temperature, the external voltage, and the orientation of the module and DIN rail. The charts below show thermal deratings for the module at 120VAC with the maximum output current per point.

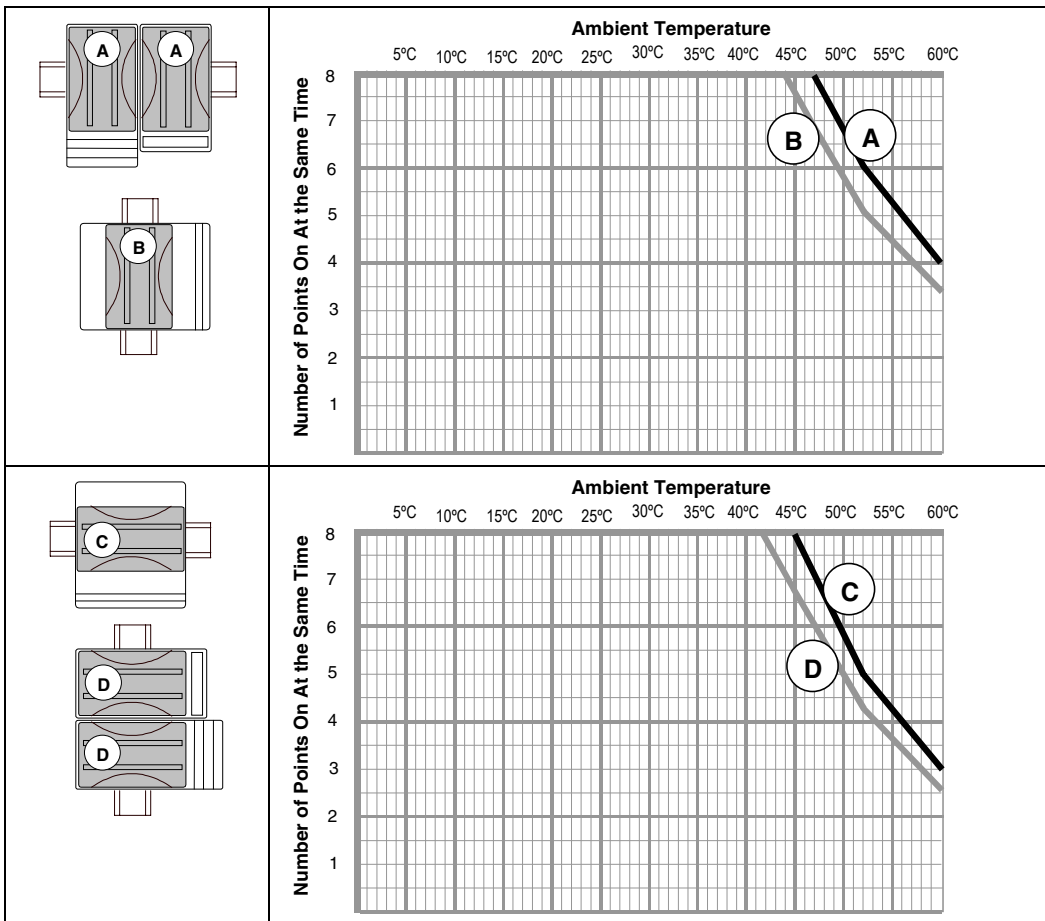

IC200MDL330 Output Module, 120VAC 0.5 Amp, Isolated 16 Points

Discrete output module IC200MDL330 provides 16 isolated outputs.

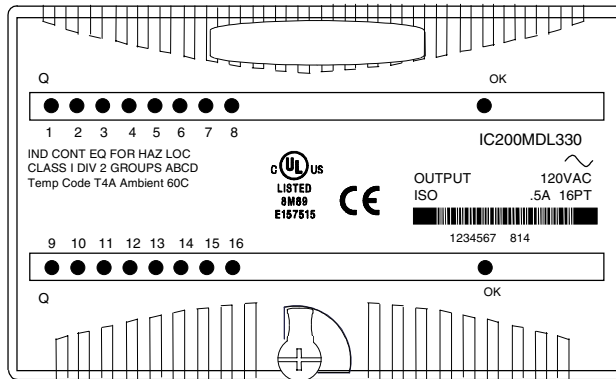

An external 120 VAC power supply must be provided to switch power to the loads.

Intelligent processing for this module is performed by the CPU or NIU. The module receives 16 bits of discrete output data.

LED Indicators

Individual green LEDs indicate the on/off state of the output points. The output LEDs are logic-driven and independent of the load conditions.

The green OK LED is on when backplane power is present to the module.

IC200MDL330
Output Module, 120VAC 0.5 Amp, Isolated 16 Points

Module Specifications

Module Characteristics	
Points	16 isolated outputs
Module ID	88408840
Isolation:	
User input to logic (optical) and to frame ground	250VAC continuous; 1500VAC for 1 minute
Group to group	250VAC continuous; 1500VAC for 1 minute
Point to point	250VAC continuous; 1500VAC for 1 minute
LED indicators	One LED per point shows individual point on/off state OK LED indicates backplane power is present
Backplane current consumption	5V output: 140mA maximum
External power supply	85 to 132VAC (47 to 63Hz), 120VAC nominal
Thermal derating	See diagrams
Output Characteristics	
Output voltage	85 to 132 VAC (47 to 63Hz), 120VAC nominal
Output voltage drop	2.0V maximum
Load current	10mA minimum per point 0.5A maximum per point 5.0A for one cycle (20ms) maximum inrush
Output leakage current	Less than 2mA at 132VAC
On response time	Less than ½ cycle, maximum
Off response time	Less than ½ cycle, maximum
Protection	Snubber and MOVs (each output)
Diagnostics	None

IC200MDL330
Output Module, 120VAC 0.5 Amp, Isolated 16 Points

Field Wiring

Terminal	Connection	Terminal	Connection
A1	Output 1	B1	Output 9
A2	Output 1 Ret	B2	Output 9 Ret
A3	Output 2	B3	Output 10
A4	Output 2 Ret	B4	Output 10 Ret
A5	Output 3	B5	Output 11
A6	Output 3 Ret	B6	Output 11 Ret
A7	Output 4	B7	Output 12
A8	Output 4 Ret	B8	Output 12 Ret
A9	Output 5	B9	Output 13
A10	Output 5 Ret	B10	Output 13 Ret
A11	Output 6	B11	Output 14
A12	Output 6 Ret	B12	Output 14 Ret
A13	Output 7	B13	Output 15
A14	Output 7 Ret	B14	Output 15 Ret
A15	Output 8	B15	Output 16
A16	Output 8 Ret	B16	Output 16 Ret
A17	No connection	B17	No connection
A18	No connection	B18	No connection

When wiring outputs to inductive loads, use of external suppression circuits is recommended. See chapter 2, "Installing Wiring for I/O Devices-Wiring to Inductive Loads" for more information.

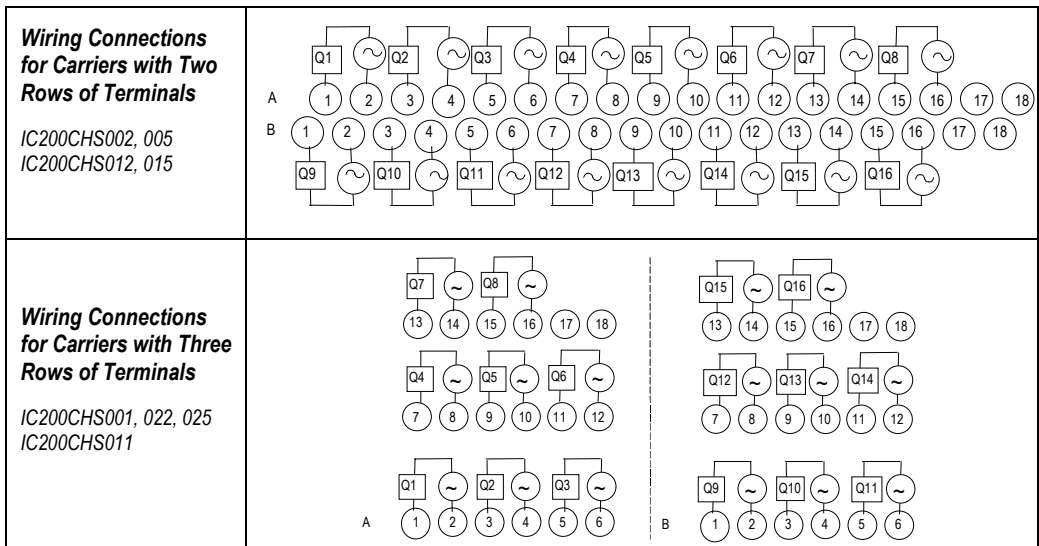

IC200MDL330
Output Module, 120VAC 0.5 Amp, Isolated 16 Points

Thermal Derating

The number of points that can be on at the same time depends on the ambient temperature, the external voltage, and the orientation of the module and DIN rail. The charts below show thermal deratings for the module at 120VAC with the maximum output current per point.

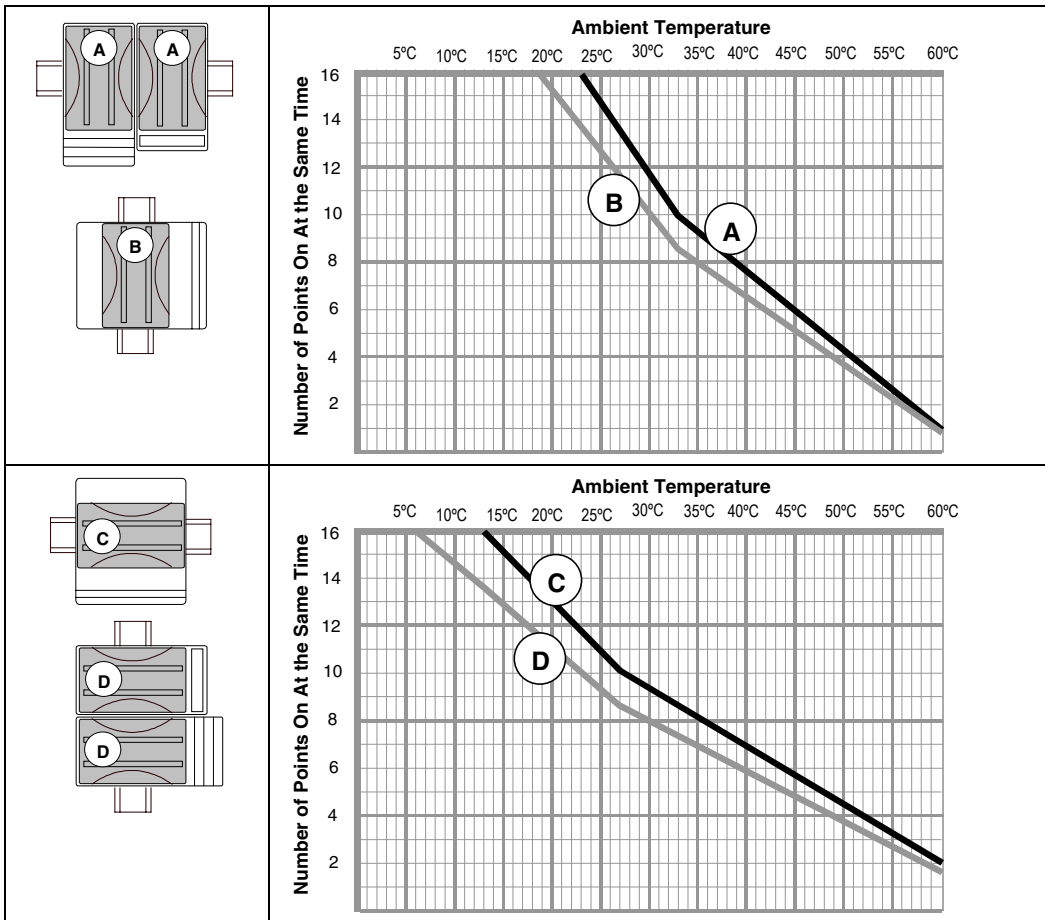

**IC200MDL331
Output Module, 120VAC 2.0 Amp, Isolated 8 Points**

Discrete output module IC200MDL331 provides 8 isolated outputs.

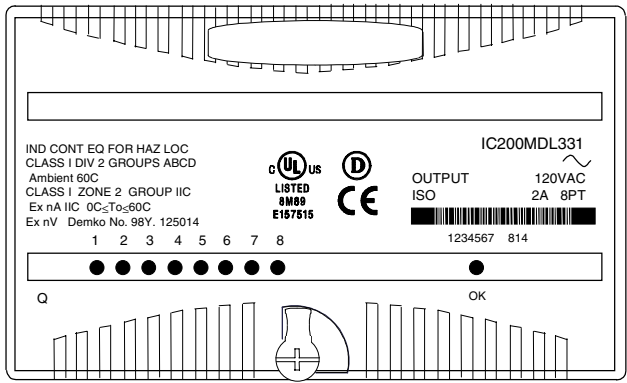

An external 120 VAC power supply must be provided to switch power to the loads.

Intelligent processing for this module is performed by the CPU or NIU. The module receives 8 bits of discrete output data.

LED Indicators

Individual green LEDs indicate the on/off state of the output points. The output LEDs are logic-driven and independent of the load conditions.

The green OK LED is on when backplane power is present to the module.

IC200MDL331
Output Module, 120VAC 2.0 Amp, Isolated 8 Points

Module Specifications

Module Characteristics	
Points	8 isolated outputs
Module ID	FFFF8840
Isolation:	
User input to logic (optical) and to frame ground	250VAC continuous; 1500VAC for 1 minute
Group to group	Not applicable
Point to point	250VAC continuous; 1500VAC for 1 minute
LED indicators	One LED per point shows individual point on/off state OK LED indicates backplane power is present
Backplane current consumption	5V output: 85mA maximum
External power supply	85 to 132VAC (47 to 63Hz), 120VAC nominal
Thermal derating	See diagrams
Output Characteristics	
Output voltage	85 to 132 VAC (47 to 63Hz), 120VAC nominal
Output voltage drop	2.0V maximum
Load current	10mA minimum per point 2.0A maximum per point 20A for one cycle (20ms) maximum inrush
Output leakage current	Less than 2mA at 132VAC
On response time	Less than ½ cycle
Off response time	Less than ½ cycle
Protection	Snubber and MOV (each output)
Diagnostics	None

IC200MDL331
Output Module, 120VAC 2.0 Amp, Isolated 8 Points

Field Wiring

Terminal	Connection	Terminal	Connection
A1	No connection	B1	Output 1
A2	No connection	B2	Output 1 Ret
A3	No connection	B3	Output 2
A4	No connection	B4	Output 2 Ret
A5	No connection	B5	Output 3
A6	No connection	B6	Output 3 Ret
A7	No connection	B7	Output 4
A8	No connection	B8	Output 4 Ret
A9	No connection	B9	Output 5
A10	No connection	B10	Output 5 Ret
A11	No connection	B11	Output 6
A12	No connection	B12	Output 6 Ret
A13	No connection	B13	Output 7
A14	No connection	B14	Output 7 Ret
A15	No connection	B15	Output 8
A16	No connection	B16	Output 8 Ret
A17	No connection	B17	No connection
A18	No connection	B18	No connection

When wiring outputs to inductive loads, use of external suppression circuits is recommended. See chapter 2, "Installing Wiring for I/O Devices-Wiring to Inductive Loads" for more information.

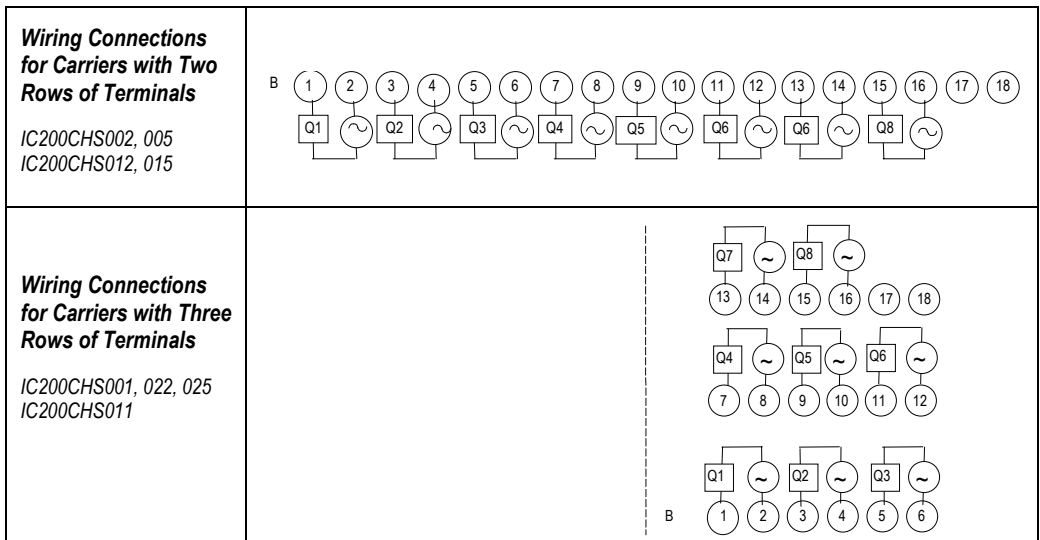

IC200MDL331
Output Module, 120VAC 2.0 Amp, Isolated 8 Points

Thermal Derating

The number of points that can be on at the same time depends on the ambient temperature, the output current, and the orientation of the module and DIN rail. The charts below show thermal deratings for the module at 120VAC with the indicated output current per point.

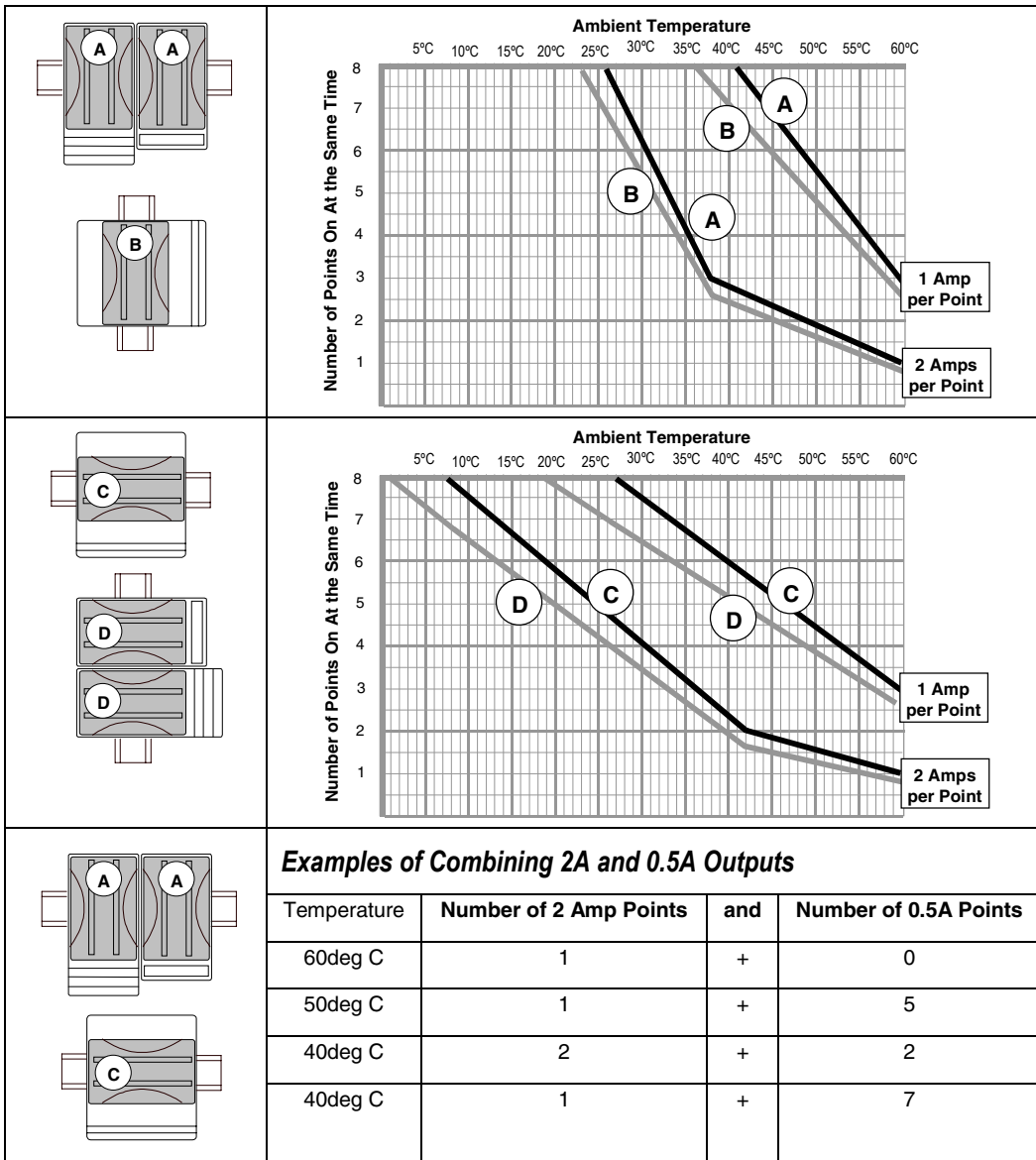

IC200MDL730 Output Module, 24VDC Positive Logic 2.0 Amps, w/ESCP 8 Points

Discrete output module IC200MDL730 provides one group of 8 discrete outputs. Each point has electronic overcurrent protection and short circuit protection, and generates a fault if either condition exists. The outputs are positive or sourcing type outputs. They switch the loads to the positive side of the DC supply and thus supply current to the loads.

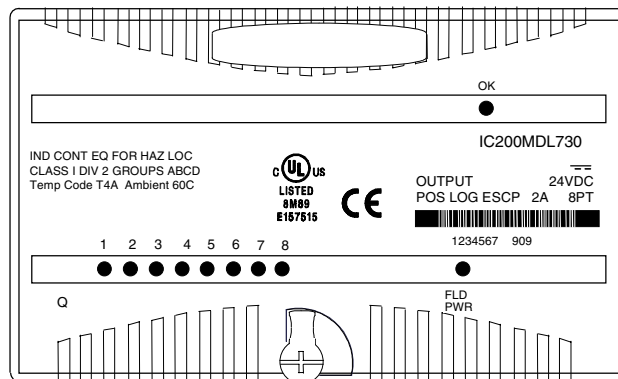

An external DC power supply must be provided to switch power to the loads.

At powerup, the backplane power supply must be on and stable for 1 second before field power is applied to the module. Failure to follow this sequence could result in false output point faults. These faults can be cleared as described below.

Intelligent processing for this module is performed by the CPU or NIU. The module receives 8 bits of discrete output data.

LED Indicators

Individual green LEDs indicate the on/off state of the output points. The LEDs are dependent on field power, but independent of load conditions.

Individual amber LEDs indicate overload or short circuit conditions on each output point.

The green FLD PWR LED is on when field power is applied to the module.

The green OK LED is on when backplane power is present to the module.

Diagnostics

The module provides point-level diagnostics (fault detection) of overload and short circuit conditions. Each point fault is identified both at the CPU/NIU and by means of an amber LED. Once an overload/short circuit condition is reported, the fault is latched. It remains latched until a Clear Fault is issued or user power to the module is cycled.

IC200MDL730

Output Module, 24VDC Positive Logic 2.0 Amps, w/ESCP 8 Points

Module Specifications

Module Characteristics	
Points	1 group of 8 outputs
Module ID	FFFF8140
Isolation:	
User input to logic (optical) and to frame ground	250VAC continuous; 1500VAC for 1 minute
Group to group	Not applicable
Point to point	None
LED indicators	One green LED per point shows individual point on/off state One amber LED per point shows individual point overloads/short circuits. FLD PWR LED indicates field power is present OK LED indicates backplane power is present
Backplane current consumption	5V output: 50mA
External power supply	+18 to +30VDC, +24VDC nominal
Thermal derating	None
Output Characteristics	
Output voltage	+17.5 to +30VDC, +24VDC nominal
Output voltage drop	0.5V maximum
Load current	2.0A at 30VDC maximum (resistive) per point, 8.0A max per module
Output leakage current	0.5mA at 30VDC maximum
On response time	0.5ms, maximum
Off response time	0.5ms, maximum
Protection (each output)	Short circuit protection, overcurrent protection

External Power Supply Requirements

The external power supply used to power the loads must provide sufficient field power for the module during short circuit events. When a load is shorted, an inadequate external power supply may allow field power to drop below the specified operating range, causing mis-operation of the module. The external power supply must be capable of providing short circuit energy without degradation of output voltage levels. The amount of energy required depends on the number of simultaneously-short-circuited points that might occur. Refer to power supply short circuit operation specifications when selecting the power supply to be used with the loads.

Local energy storage (either batteries or capacitors) can be used to compensate for insufficient power supply characteristics. Additional best practices including minimizing wiring resistance from the external power supply to the module must be observed.

IC200MDL730
Output Module, 24VDC Positive Logic 2.0 Amps, w/ESCP 8 Points

Field Wiring

Terminal	Connection	Terminal	Connection
A1	No connection	B1	Output 1
A2	No connection	B2	No connection
A3	No connection	B3	Output 2
A4	No connection	B4	No connection
A5	No connection	B5	Output 3
A6	No connection	B6	No connection
A7	No connection	B7	Output 4
A8	No connection	B8	No connection
A9	No connection	B9	Output 5
A10	No connection	B10	No connection
A11	No connection	B11	Output 6
A12	No connection	B12	No connection
A13	No connection	B13	Output 7
A14	No connection	B14	No connection
A15	No connection	B15	Output 8
A16	No connection	B16	No connection
A17	No connection	B17	Common (Return)
A18	No connection	B18	+24VDC

The 8 outputs form one group with a DC+ and a DC- terminal.

If additional bussed terminals are needed, the A terminals can be made available by using a shorting bar. The shorting bar has a maximum current-carrying capacity of 2A per point. See chapter 2 for additional information about using the shorting bar.

When wiring outputs to inductive loads, use of external suppression circuits is recommended. See chapter 2, "Installing Wiring for I/O Devices-Wiring to Inductive Loads" for more information.

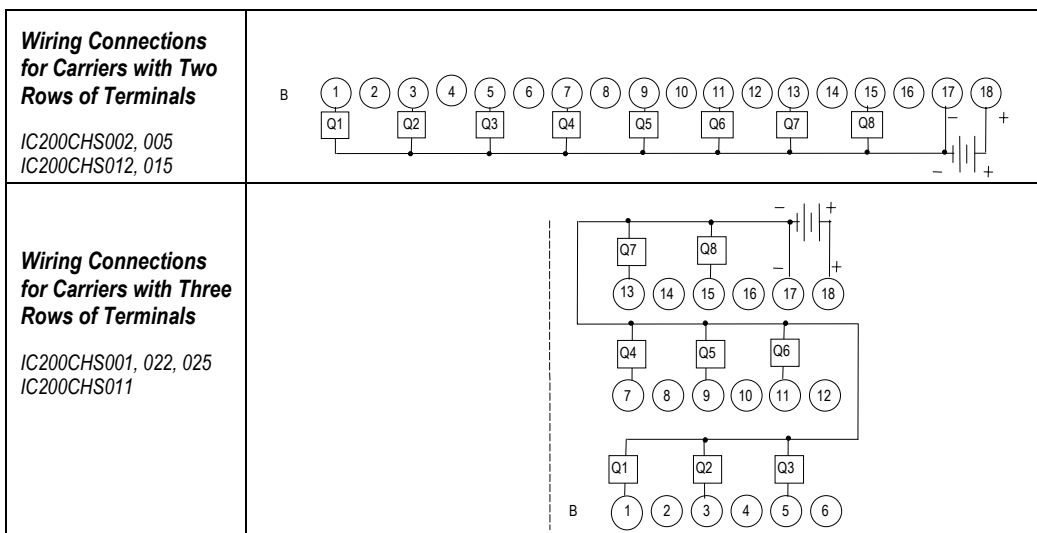

IC200MDL740

Output Module, 12/24VDC Positive Logic 0.5 Amp, 16 Points

Discrete output module IC200MDL740 provides one group of 16 discrete outputs. The outputs are positive or sourcing type outputs. They switch the loads to the positive side of the DC supply and thus supply current to the loads.

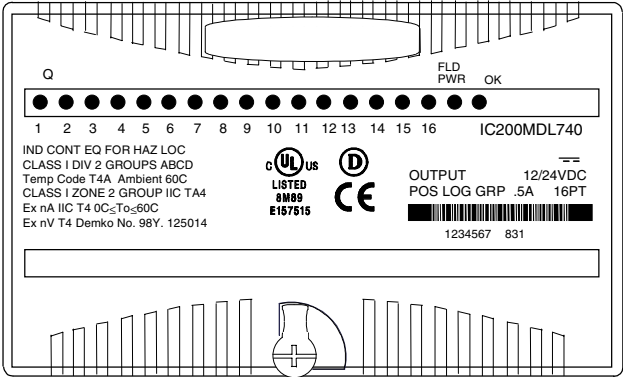

Note: 12V output functionality requires module version IC200MDL740B or higher.
An external DC power supply must be provided to switch power to the loads.
Intelligent processing for this module is performed by the CPU or NIU. The module receives 16 bits of discrete output data.

LED Indicators

Individual green LEDs indicate the on/off state of the output points. The LEDs are dependent on field power, but independent of load conditions.
The green FLD PWR LED is on when field power is applied to the module.
The green OK LED is on when backplane power is present to the module.

IC200MDL740
Output Module, 12/24VDC Positive Logic 0.5 Amp, 16 Points

Module Specifications

Module Characteristics	
Points	1 group of 16 outputs
Module ID	FFFF8080
Isolation:	
User input to logic (optical) and to frame ground	250VAC continuous; 1500VAC for 1 minute
Group to group	Not applicable
Point to point	None
LED indicators	One LED per point shows individual point on/off state FLD PWR LED indicates field power is present OK LED indicates backplane power is present
Backplane current consumption	5V output: 45mA maximum
External power supply	+10.2 to +30VDC, +12/24VDC nominal
Thermal derating	See diagram
Output Characteristics	
Output voltage	+10.2 to +30VDC, +12/24VDC nominal
Output voltage drop	0.3V maximum
Load current	0.5A at 30VDC maximum (resistive) 2.0A inrush maximum for 100ms
Output leakage current	0.5mA at 30VDC maximum
On response time	0.2ms, maximum
Off response time	1.0ms, maximum
Protection (each output)	No internal fuse

IC200MDL740

Output Module, 12/24VDC Positive Logic 0.5 Amp, 16 Points

Field Wiring

Terminal	Connection	Terminal	Connection
A1	Output 1	B1	No connection
A2	Output 2	B2	No connection
A3	Output 3	B3	No connection
A4	Output 4	B4	No connection
A5	Output 5	B5	No connection
A6	Output 6	B6	No connection
A7	Output 7	B7	No connection
A8	Output 8	B8	No connection
A9	Output 9	B9	No connection
A10	Output 10	B10	No connection
A11	Output 11	B11	No connection
A12	Output 12	B12	No connection
A13	Output 13	B13	No connection
A14	Output 14	B14	No connection
A15	Output 15	B15	No connection
A16	Output 16	B16	No connection
A17	DC -	B17	No connection
A18	DC +	B18	No connection

The 16 outputs form one group with a DC+ and a DC- terminal. If additional bussed terminals are needed, the B terminals can be made available by using a shorting bar. The shorting bar has a maximum current-carrying capacity of 2A per point. See chapter 2 for additional information about using the shorting bar.

When wiring outputs to inductive loads, use of external suppression circuits is recommended. See chapter 2, "Installing Wiring for I/O Devices-Wiring to Inductive Loads" for more information.

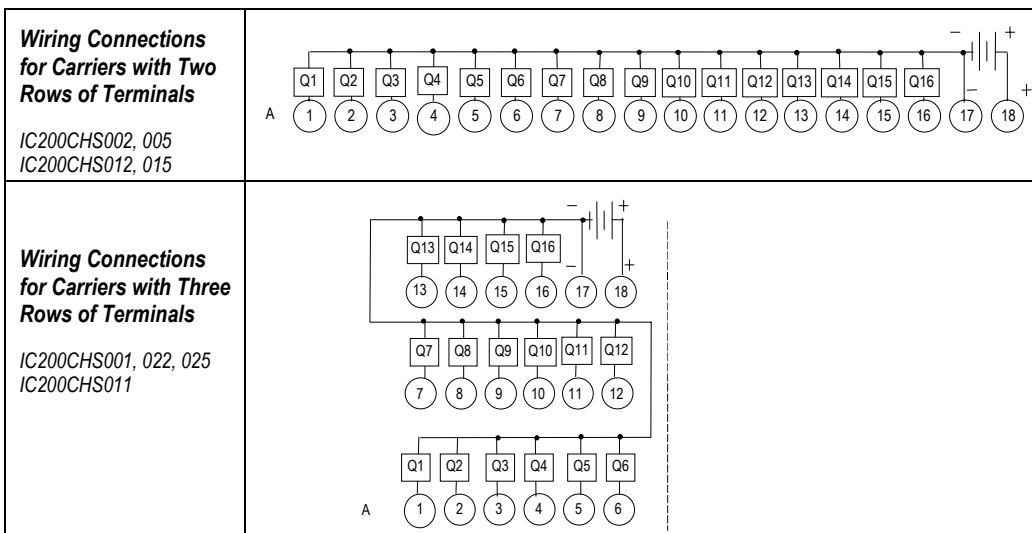

IC200MDL740
Output Module, 12/24VDC Positive Logic 0.5 Amp, 16 Points

Thermal Derating

The number of points that can be on at the same time depends on the ambient temperature, the external voltage, and the orientation of the module and DIN rail. The charts below show thermal deratings for the module at 24VDC and 30VDC with the maximum output current per point.

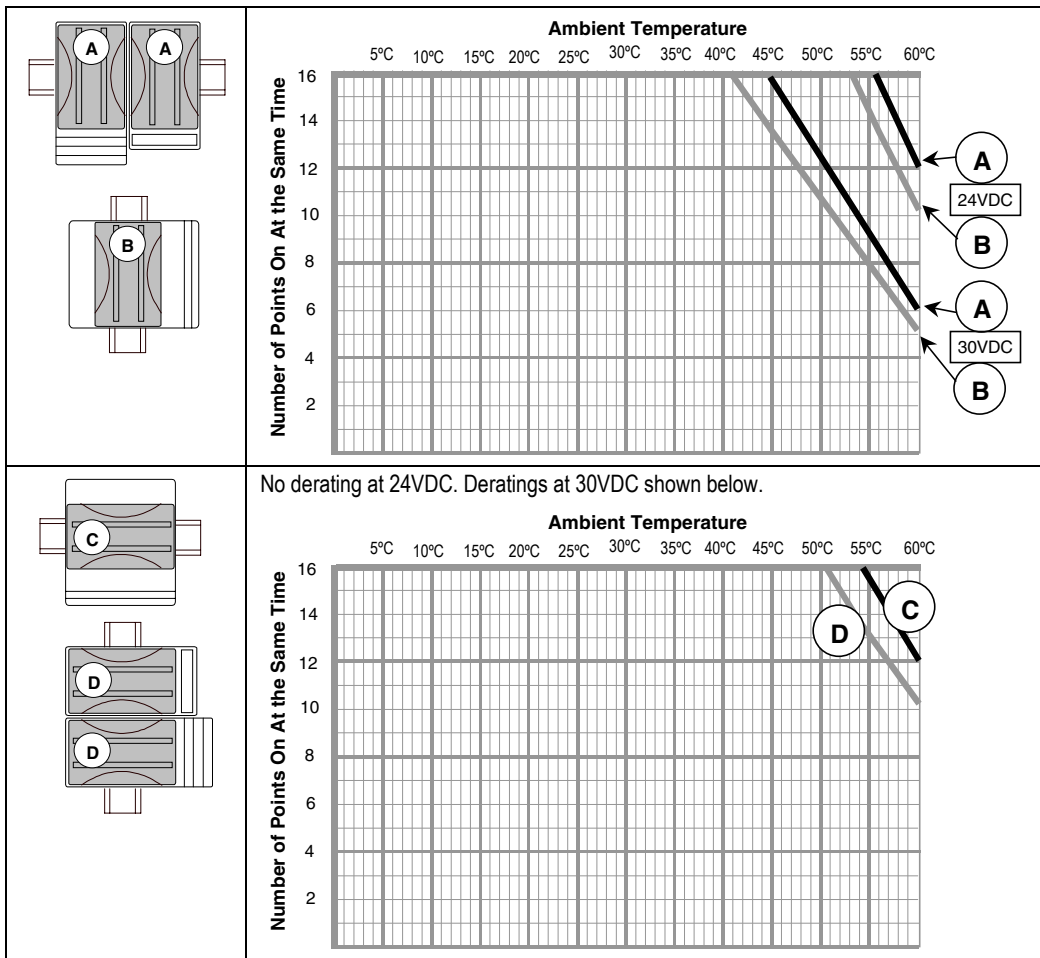

IC200MDL741

Output Module, 24VDC Positive Logic 0.5 Amp, w/ESCP 16 Points

Discrete output module IC200MDL741 provides one group of 16 discrete outputs. Each point has electronic overcurrent protection and short circuit protection, and generates a fault if either condition exists. The outputs are positive or sourcing type outputs. They switch the loads to the positive side of the DC supply and thus supply current to the loads.

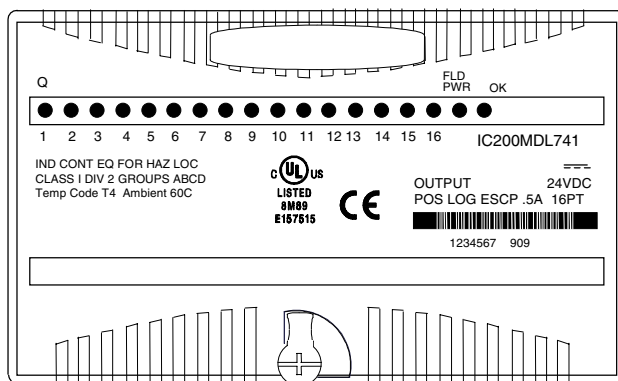

An external DC power supply must be provided to switch power to the loads.

Intelligent processing for this module is performed by the CPU or NIU. The module receives 16 bits of discrete output data.

LED Indicators

Individual green LEDs indicate the on/off state of the output points. The LEDs are dependent on field power, but independent of load conditions.

Individual amber LEDs indicate overload conditions on each output point.

The green FLD PWR LED is on when field power is applied to the module.

The green OK LED is on when backplane power is present to the module.

Diagnostics

The module reports the presence of any overloaded points to the system on a per-module basis. Amber LEDs indicate the overload conditions on a per-point basis. Once the overload condition is removed, normal operation is resumed.

IC200MDL741
Output Module, 24VDC Positive Logic 0.5 Amp, w/ESCP 16 Points

Module Specifications

Module Characteristics	
Points	1 group of 16 outputs
Module ID	FFFF8080
Isolation:	
User input to logic (optical) and to frame ground	250VAC continuous; 1500VAC for 1 minute
Group to group	Not applicable
Point to point	None
LED indicators	One green LED per point shows individual point on/off state One amber LED per point shows individual point overloads FLD PWR LED indicates field power is present OK LED indicates backplane power is present
Backplane current consumption	5V output: 75mA maximum
External power supply	+18 to +30VDC, +24VDC nominal
Thermal derating	See diagrams
Output Characteristics	
Output voltage	+18 to +30VDC, +24VDC nominal
Output voltage drop	0.5V maximum
Load current	0.5A at 30VDC maximum (resistive) 2.0A inrush maximum for 100ms
Steady-state overcurrent trip point	1.6A typ., 0.7A to 2.5A max range
Output leakage current	0.5mA at 30VDC maximum
On response time	0.5ms, maximum
Off response time	0.5ms, maximum
Protection (each output)	Short circuit protection, overcurrent protection, free-wheeling diodes

External Power Supply Requirements

The external power supply used to power the loads must provide sufficient field power for the module during short circuit events. When a load is shorted, an inadequate external power supply may allow field power to drop below the specified operating range, causing misoperation of the module. The external power supply must be capable of providing short circuit energy without degradation of output voltage levels. The amount of energy required depends on the number of simultaneously-shortened points that might occur. Refer to power supply short circuit operation specifications when selecting the power supply to be used with the loads.

Local energy storage (either batteries or capacitors) can be used to compensate for insufficient power supply characteristics. Additional best practices including minimizing wiring resistance from the external power supply to the module must be observed.

IC200MDL741
Output Module, 24VDC Positive Logic 0.5 Amp, w/ESCP 16 Points

Field Wiring

Terminal	Connection	Terminal	Connection
A1	Output 1	B1	No connection
A2	Output 2	B2	No connection
A3	Output 3	B3	No connection
A4	Output 4	B4	No connection
A5	Output 5	B5	No connection
A6	Output 6	B6	No connection
A7	Output 7	B7	No connection
A8	Output 8	B8	No connection
A9	Output 9	B9	No connection
A10	Output 10	B10	No connection
A11	Output 11	B11	No connection
A12	Output 12	B12	No connection
A13	Output 13	B13	No connection
A14	Output 14	B14	No connection
A15	Output 15	B15	No connection
A16	Output 16	B16	No connection
A17	DC -	B17	No connection
A18	DC +	B18	No connection

The 16 outputs form one group with a DC+ and a DC- terminal. If additional bussed terminals are needed, the B terminals can be made available by using a shorting bar. The shorting bar has a maximum current-carrying capacity of 2 Amps per point. See chapter 2 for additional information about using the shorting bar.

When wiring outputs to inductive loads, use of external suppression circuits is recommended. See chapter 2, "Installing Wiring for I/O Devices-Wiring to Inductive Loads" for more information.

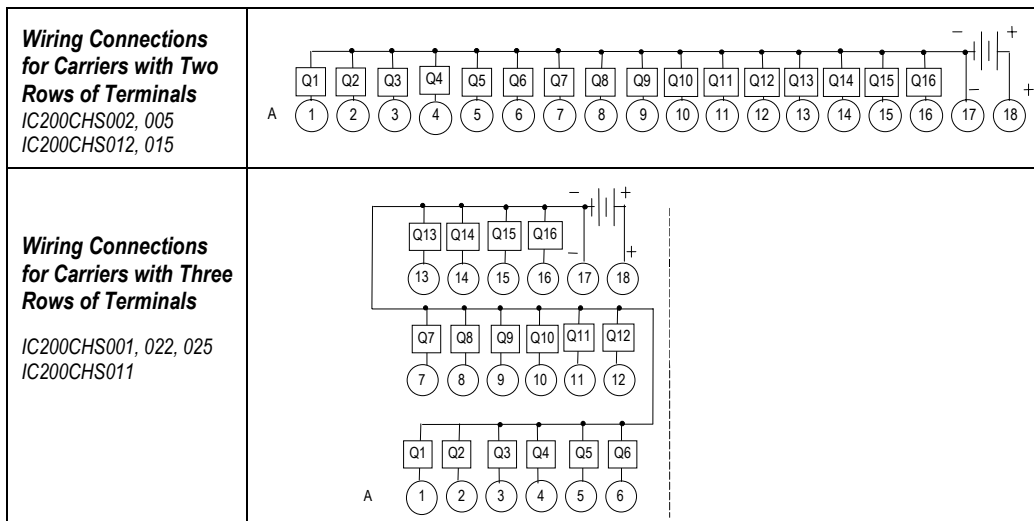

IC200MDL741
Output Module, 24VDC Positive Logic 0.5 Amp, w/ESCP 16 Points

Thermal Derating

The number of points that can be on at the same time depends on the ambient temperature, the external voltage, and the orientation of the module and DIN rail. The charts below show thermal deratings for the module at 24VDC and 30VDC with the maximum output current per point.

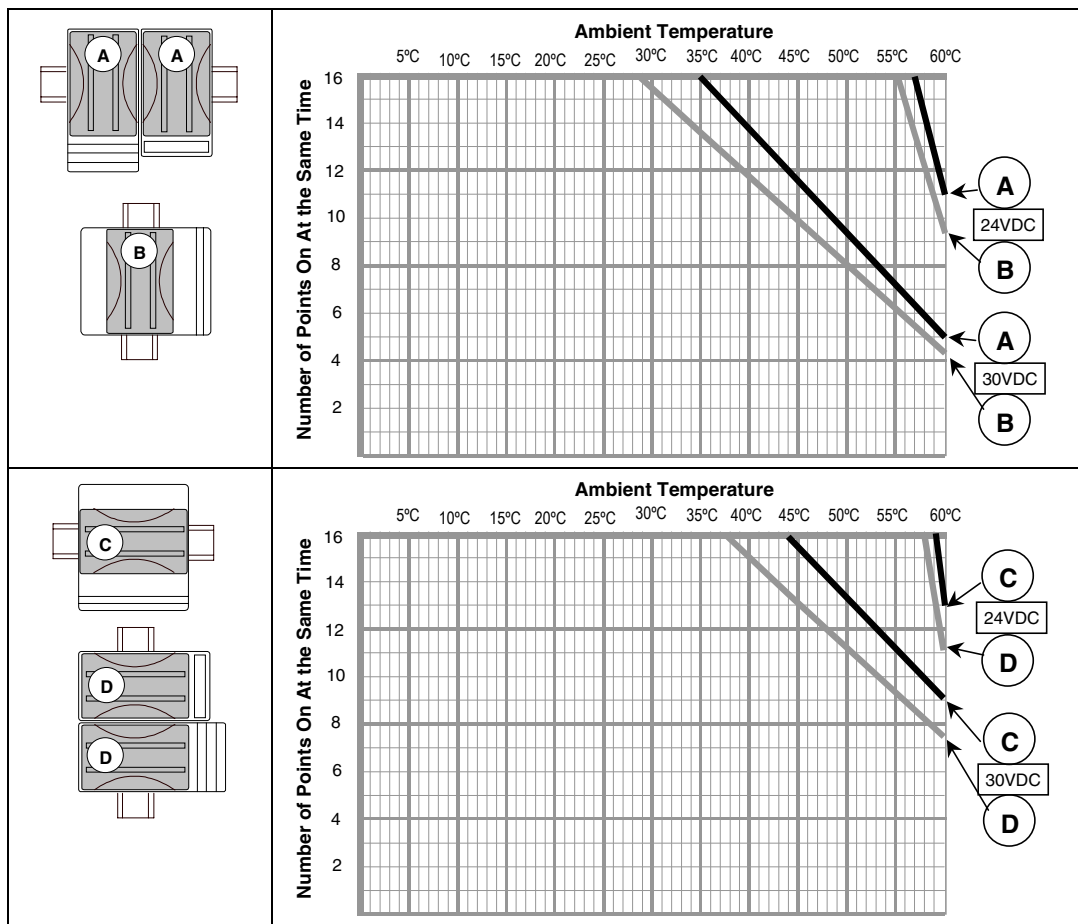

IC200MDL742

Output Module, 24VDC Positive Logic 0.5 Amp, w/ESCP 32 Points

Discrete output module IC200MDL742 provides two groups of 16 discrete outputs. Each point has electronic overcurrent protection and short circuit protection, and generates a fault if either condition exists. The outputs are positive or sourcing type outputs. They switch the loads to the positive side of the DC supply and thus supply current to the loads.

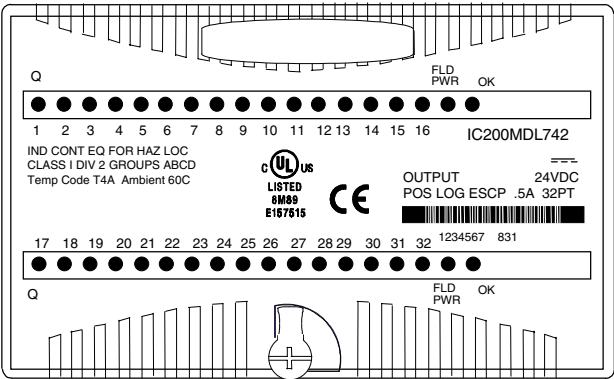

An external DC power supply must be provided to switch power to the loads.

Intelligent processing for this module is performed by the CPU or NIU. The module receives 32 bits of discrete output data.

LED Indicators

Individual green LEDs indicate the on/off state of the output points. The LEDs are dependent on field power, but independent of load conditions.

Individual amber LEDs indicate overload conditions on each output point.

The green FLD PWR LED is on when field power is applied to the module.

The green OK LED is on when backplane power is present to the module.

Diagnostics

The module reports the presence of any overloaded points to the system on a per-module basis. Amber LEDs indicate the overload conditions on a per-point basis. Once the overload condition is removed, normal operation is resumed.

IC200MDL742**Output Module, 24VDC Positive Logic 0.5 Amp, w/ESCP 32 Points****Module Specifications**

Module Characteristics	
Points	2 groups of 16 outputs
Module ID	80808080
Isolation:	
User input to logic (optical) and to frame ground	250VAC continuous; 1500VAC for 1 minute
Group to group	250VAC continuous; 1500VAC for 1 minute
Point to point	None
LED indicators	One green LED per point shows individual point on/off state One amber LED per point shows individual point overloads FLD PWR LED indicates field power is present OK LED indicates backplane power is present
Backplane current consumption	5V output: 150mA maximum
External power supply	+18 to +30VDC, +24VDC nominal
Thermal derating	See diagram
Output Characteristics	
Output voltage	+18 to +30VDC, +24VDC nominal
Output voltage drop	0.5V maximum
Load current	0.5A at 30VDC maximum (resistive) 2.0A inrush maximum for 100ms
Steady-state overcurrent trip point	1.6A typ., 0.7A to 2.5A max range
Output leakage current	0.5mA at 30VDC maximum
On response time	0.5ms, maximum
Off response time	0.5ms, maximum
Protection (each output)	Short circuit protection, overcurrent protection, free-wheeling diodes

External Power Supply Requirements

The external power supply used to power the loads must provide sufficient field power for the module during short circuit events. When a load is shorted, an inadequate external power supply may allow field power to drop below the specified operating range, causing misoperation of the module. The external power supply must be capable of providing short circuit energy without degradation of output voltage levels. The amount of energy required depends on the number of simultaneously-short-circuited points that might occur. Refer to power supply short circuit operation specifications when selecting the power supply to be used with the loads.

Local energy storage (either batteries or capacitors) can be used to compensate for insufficient power supply characteristics. Additional best practices including minimizing wiring resistance from the external power supply to the module must be observed.

IC200MDL742

Output Module, 24VDC Positive Logic 0.5 Amp, w/ESCP 32 Points

Thermal Derating

The number of points that can be on at the same time depends on the ambient temperature, the external voltage, and the orientation of the module and DIN rail. The charts below show thermal deratings for the module at 24VDC and 30VDC with the maximum output current per point.

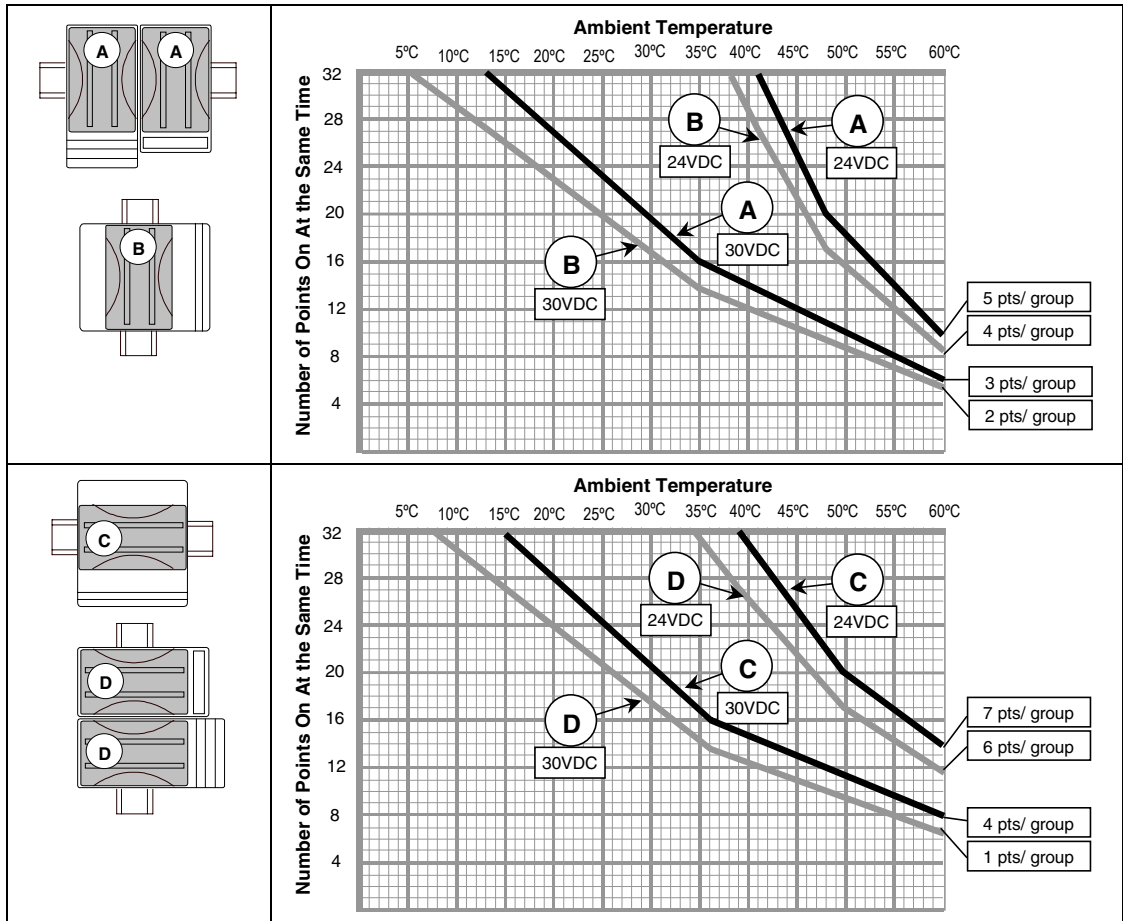

IC200MDL742
Output Module, 24VDC Positive Logic 0.5 Amp, w/ESCP 32 Points

Field Wiring

Terminal	Connection	Terminal	Connection
A1	Output 1	B1	Output 17
A2	Output 2	B2	Output 18
A3	Output 3	B3	Output 19
A4	Output 4	B4	Output 20
A5	Output 5	B5	Output 21
A6	Output 6	B6	Output 22
A7	Output 7	B7	Output 23
A8	Output 8	B8	Output 24
A9	Output 9	B9	Output 25
A10	Output 10	B10	Output 26
A11	Output 11	B11	Output 27
A12	Output 12	B12	Output 28
A13	Output 13	B13	Output 29
A14	Output 14	B14	Output 30
A15	Output 15	B15	Output 31
A16	Output 16	B16	Output 32
A17	DC -	B17	DC -
A18	DC +	B18	DC +

The 16 outputs form one group with a DC+ and a DC- terminal.

When wiring outputs to inductive loads, use of external suppression circuits is recommended. See chapter 2, "Installing Wiring for I/O Devices-Wiring to Inductive Loads" for more information.

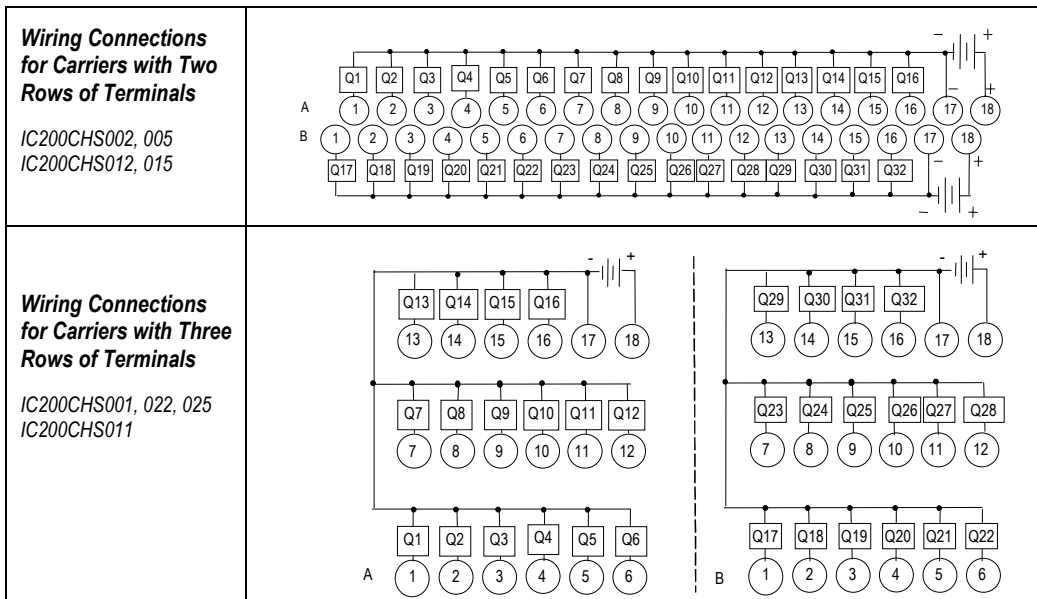

IC200MDL743

Output Module, 5/12/24V DC Negative Logic 0.5 Amp, 16 Points

Discrete output module IC200MDL743 provides one group of 16 discrete outputs. The outputs are negative or sinking type outputs. They switch the loads to the negative (return) side of the DC supply and thus receive current from the loads.

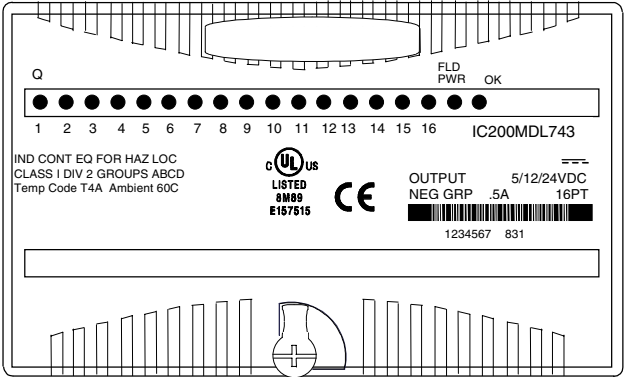

An external DC power supply must be provided to switch power to the loads.

Intelligent processing for this module is performed by the CPU or NIU. The module receives 16 bits of discrete output data.

LED Indicators

Individual green LEDs indicate the on/off state of the output points. The LEDs are powered from the backplane. LED operation is dependent on the application of valid field power, but independent of load conditions.

The green FLD PWR LED is on when field power is applied to the module.

The green OK LED is on when backplane power is present to the module.

IC200MDL743
Output Module, 5/12/24V DC Negative Logic 0.5 Amp, 16 Points

Module Specifications

Module Characteristics	
Points	1 group of 16 outputs
Module ID	FFFF8080
Isolation:	
User input to logic (optical) and to frame ground	250VAC continuous; 1500VAC for 1 minute
Group to group	Not applicable
Point to point	None
LED indicators	One LED per point shows individual point on/off state FLD PWR LED indicates field power is present OK LED indicates backplane power is present
Backplane current consumption	5V output: 70mA maximum
External power supply:	
5VDC-TTL mode	+4.75 to +5.25VDC, +5VDC nominal
12/24VDC mode	+10.2 to +30VDC, +12/24VDC nominal
Thermal derating	No derating required.
Output Characteristics	
Output voltage:	
5VDC-TTL mode	+4.75 to +5.25VDC, +5VDC nominal
12/24VDC mode	+10.2 to +30VDC, +12/24VDC nominal
Output voltage drop:	
5VDC-TTL mode	0.4V maximum
12/24VDC mode	0.3V maximum
Load current:	
5VDC-TTL mode	25mA maximum
12/24VDC mode	0.5A at 30VDC maximum (resistive) 2.0A inrush maximum for 100ms
Output leakage current	0.5mA at 30VDC maximum
On response time	0.2ms maximum
Off response time	1.0ms maximum
Protection (each output)	No internal fuse

IC200MDL743
Output Module, 5/12/24V DC Negative Logic 0.5 Amp, 16 Points

Field Wiring

The 16 outputs form one group with a DC+ and a DC- terminal.

Terminal	Connection	Terminal	Connection
A1	Output 1	B1	No connection
A2	Output 2	B2	No connection
A3	Output 3	B3	No connection
A4	Output 4	B4	No connection
A5	Output 5	B5	No connection
A6	Output 6	B6	No connection
A7	Output 7	B7	No connection
A8	Output 8	B8	No connection
A9	Output 9	B9	No connection
A10	Output 10	B10	No connection
A11	Output 11	B11	No connection
A12	Output 12	B12	No connection
A13	Output 13	B13	No connection
A14	Output 14	B14	No connection
A15	Output 15	B15	No connection
A16	Output 16	B16	No connection
A17	DC -	B17	No connection
A18	DC +	B18	No connection

If additional bussed terminals are needed, the B terminals can be made available by using a shorting bar. The shorting bar has a maximum current-carrying capacity of 2A per point. See chapter 2 for additional information about using the shorting bar.

When wiring outputs to inductive loads, use of external suppression circuits is recommended. See chapter 2, "Installing Wiring for I/O Devices-Wiring to Inductive Loads" for more information.

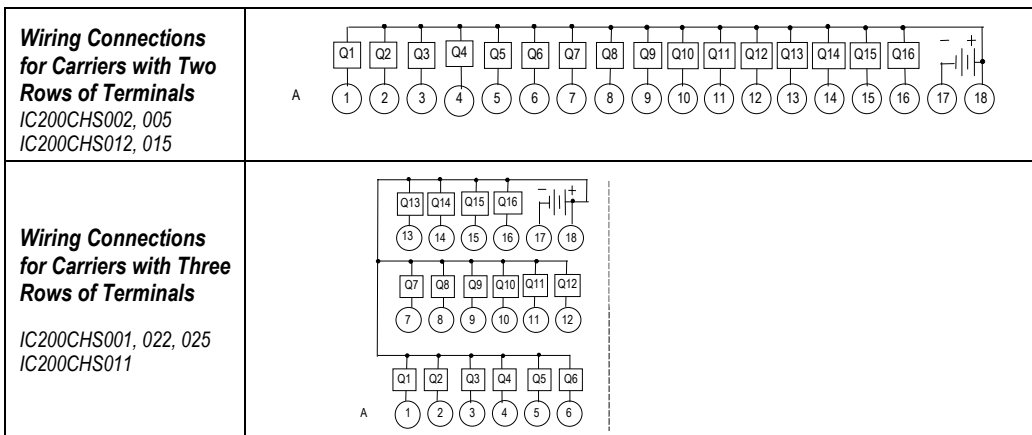

IC200MDL744 **Output Module, 5/12/24VDC Negative Logic 0.5 Amp, 32 Points**

Discrete output module IC200MDL744 provides two groups of 16 discrete outputs. The outputs are negative or sinking type outputs. They switch the loads to the negative (return) side of the DC supply and thus receive current from the loads.

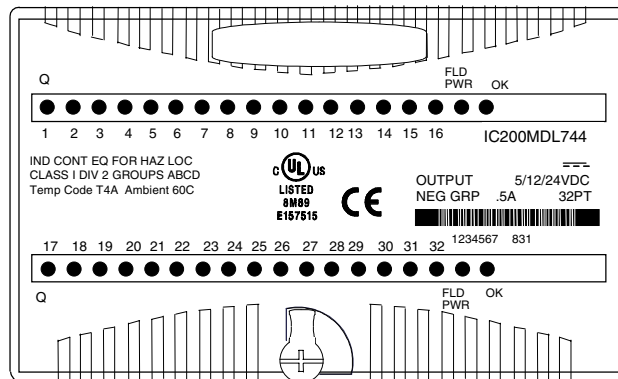

An external DC power supply must be provided to switch power to the loads.

Intelligent processing for this module is performed by the CPU or NIU. The module receives 32 bits of discrete output data.

LED Indicators

Individual green LEDs indicate the on/off state of the output points. The LEDs are powered from the backplane. LED operation is dependent on the application of valid field power, but independent of load conditions.

The green FLD PWR LED is on when field power is applied to the module.

The green OK LED is on when backplane power is present to the module.

IC200MDL744

Output Module, 5/12/24VDC Negative Logic 0.5 Amp, 32 Points

Module Specifications

Module Characteristics	
Points	2 groups of 16 outputs
Module ID	80808080
Isolation:	
User input to logic (optical) and to frame ground	250VAC continuous; 1500VAC for 1 minute
Group to group	250VAC continuous; 1500VAC for 1 minute
Point to point	None
LED indicators	One LED per point shows individual point on/off state FLD PWR LED indicates field power is present OK LED indicates backplane power is present
Backplane current consumption	5V output: 140mA maximum
External power supply:	
5VDC-TTL mode	+4.75 to +5.25VDC, +5VDC nominal
12/24VDC mode	+10.2 to +30VDC, +12/24VDC nominal
Thermal derating	See diagrams
Output Characteristics	
Output voltage:	
5VDC-TTL mode	+4.75 to +5.25VDC, +5VDC nominal
12/24VDC mode	+10.2 to +30VDC, +12/24VDC nominal
Output voltage drop:	
5VDC-TTL mode	0.4V maximum
12/24VDC mode	0.3V maximum
Load current:	
5VDC-TTL mode	25mA maximum
12/24VDC mode	0.5A at 30VDC maximum (resistive) 2.0A inrush maximum for 100ms
Output leakage current	0.5mA at 30VDC maximum
On response time	0.2ms maximum
Off response time	1.0ms maximum
Protection	No internal fuses

IC200MDL744
Output Module, 5/12/24VDC Negative Logic 0.5 Amp, 32 Points

Field Wiring

Terminal	Connection	Terminal	Connection
A1	Output 1	B1	Output 17
A2	Output 2	B2	Output 18
A3	Output 3	B3	Output 19
A4	Output 4	B4	Output 20
A5	Output 5	B5	Output 21
A6	Output 6	B6	Output 22
A7	Output 7	B7	Output 23
A8	Output 8	B8	Output 24
A9	Output 9	B9	Output 25
A10	Output 10	B10	Output 26
A11	Output 11	B11	Output 27
A12	Output 12	B12	Output 28
A13	Output 13	B13	Output 29
A14	Output 14	B14	Output 30
A15	Output 15	B15	Output 31
A16	Output 16	B16	Output 32
A17	DC -	B17	DC -
A18	DC +	B18	DC +

The 32 outputs form two groups, each with a DC+ and a DC- terminal.

When wiring outputs to inductive loads, use of external suppression circuits is recommended. See chapter 2, "Installing Wiring for I/O Devices-Wiring to Inductive Loads" for more information.

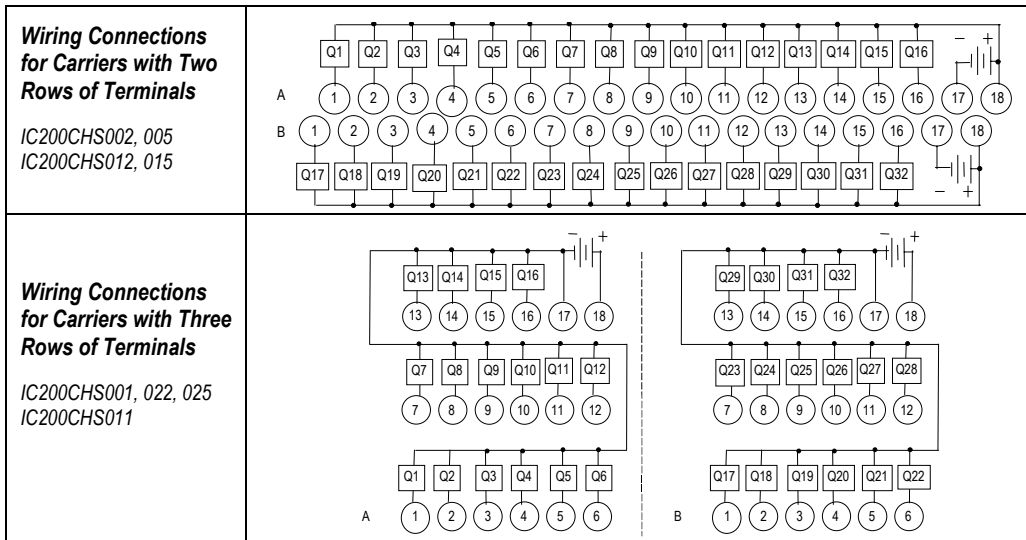

IC200MDL744
Output Module, 5/12/24VDC Negative Logic 0.5 Amp, 32 Points

Thermal Derating

The number of points that can be on at the same time depends on the ambient temperature, the external voltage, and the orientation of the module and DIN rail. The charts below show thermal deratings for the module at 24VDC and 30VDC with the maximum output current per point.

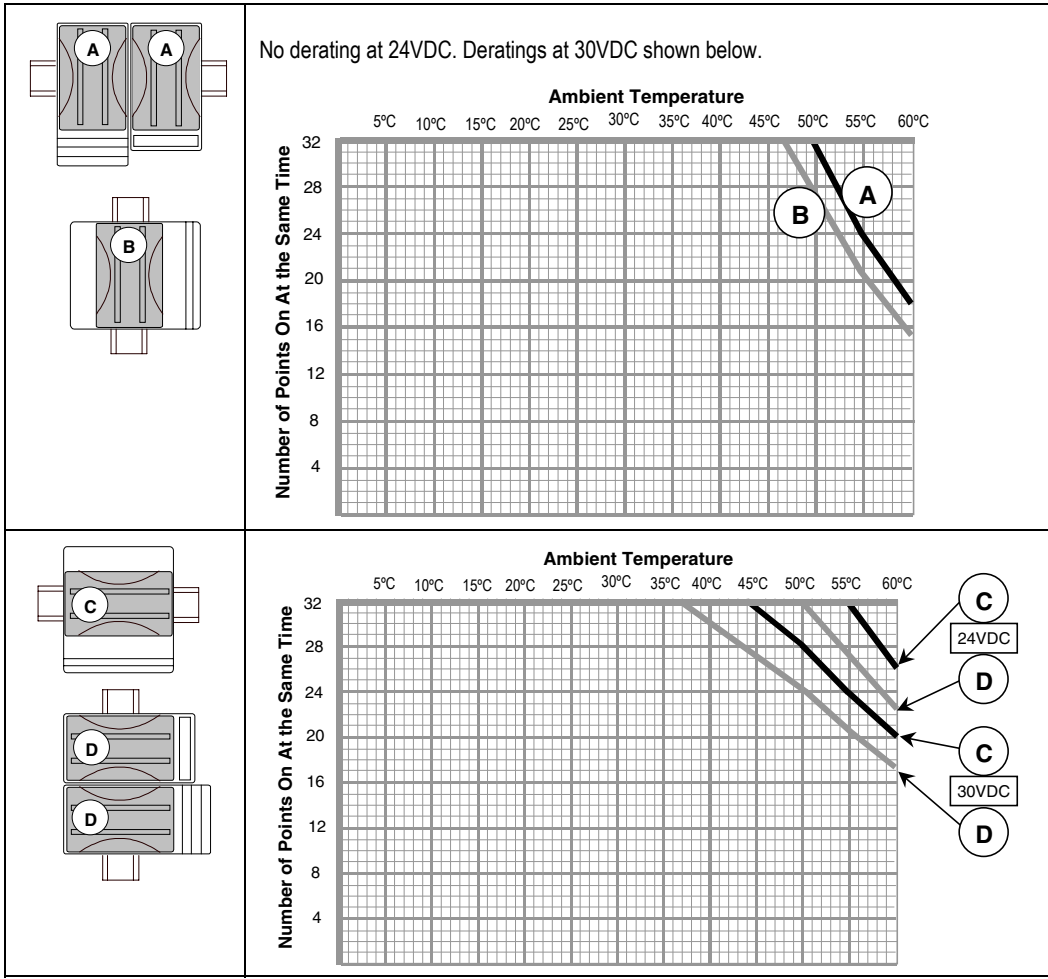

IC200MDL750
Output Module, 12/24VDC Positive Logic 0.5 Amp, 32 Points

Discrete output module IC200MDL750 provides two groups of 16 discrete outputs. The outputs are positive or sourcing type outputs. They switch the loads to the positive side of the DC supply and thus supply current to the loads.

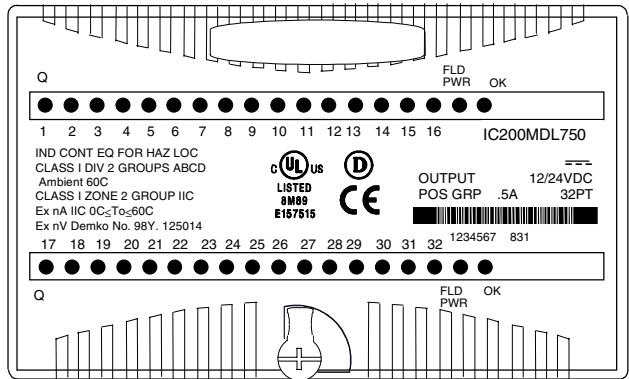

Note: 12V output functionality requires module version IC200MDL750B or higher.

An external DC power supply must be provided to switch power to the loads.

Intelligent processing for this module is performed by the CPU or NIU. The module receives 32 bits of discrete output data.

LED Indicators

Individual green LEDs indicate the on/off state of the output points. Operation of these LEDs is dependent on field power but independent of load conditions.

The green FLD PWR LED is on when field power is applied to the module.

The green OK LED is on when backplane power is present to the module.

IC200MDL750

Output Module, 12/24VDC Positive Logic 0.5 Amp, 32 Points

Module Specifications

Module Characteristics	
Points	2 groups of 16 outputs
Module ID	80808080
Isolation:	
User input to logic (optical) and to frame ground	250VAC continuous; 1500VAC for 1 minute
Group to group	250VAC continuous; 1500VAC for 1 minute
Point to point	None
LED indicators	One LED per point shows individual point on/off state FLD PWR LED indicates field power is present OK LED indicates backplane power is present
Backplane current consumption	5V output: 90mA maximum
External power supply	+10.2 to +30VDC, +12/24VDC nominal
Thermal derating	See diagrams
Output Characteristics	
Output voltage	+10.2 to +30VDC, +12/24VDC nominal
Output voltage drop	0.3V maximum
Load current	0.5A at 30VDC maximum (resistive) 2.0A maximum for 100ms inrush
Output leakage current	0.5mA at 30VDC maximum
On response time	0.2ms, maximum
Off response time	1.0ms maximum
Protection	No internal fuses

IC200MDL750
Output Module, 12/24VDC Positive Logic 0.5 Amp, 32 Points

Field Wiring

Terminal	Connection	Terminal	Connection
A1	Output 1	B1	Output 17
A2	Output 2	B2	Output 18
A3	Output 3	B3	Output 19
A4	Output 4	B4	Output 20
A5	Output 5	B5	Output 21
A6	Output 6	B6	Output 22
A7	Output 7	B7	Output 23
A8	Output 8	B8	Output 24
A9	Output 9	B9	Output 25
A10	Output 10	B10	Output 26
A11	Output 11	B11	Output 27
A12	Output 12	B12	Output 28
A13	Output 13	B13	Output 29
A14	Output 14	B14	Output 30
A15	Output 15	B15	Output 31
A16	Output 16	B16	Output 32
A17	DC -	B17	DC -
A18	DC +	B18	DC +

The 32 outputs form two groups, each with a DC+ and a DC- terminal.

When wiring outputs to inductive loads, use of external suppression circuits is recommended. See chapter 2, "Installing Wiring for I/O Devices-Wiring to Inductive Loads" for more information.

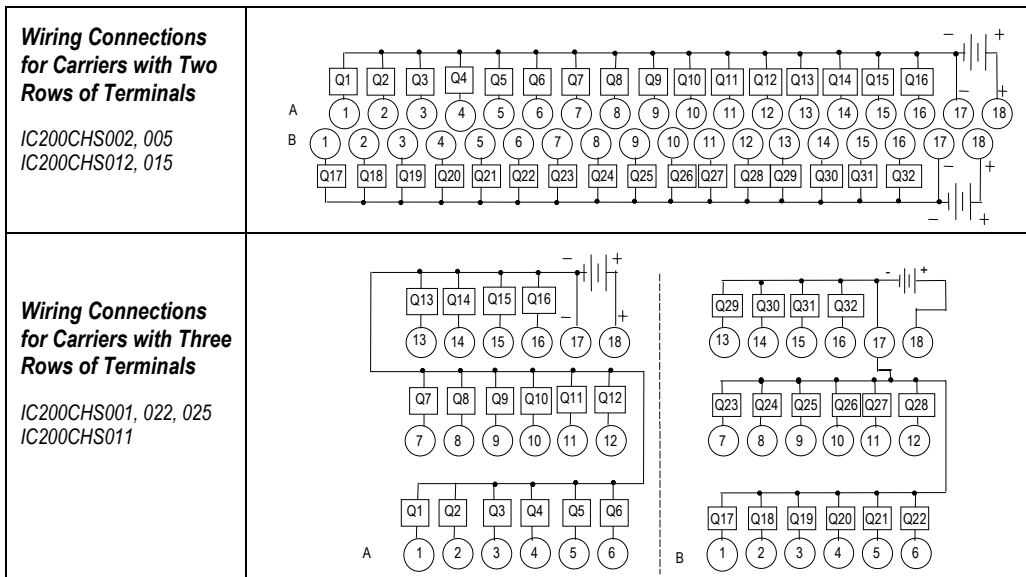

IC200MDL750

Output Module, 12/24VDC Positive Logic 0.5 Amp, 32 Points

Thermal Derating

The number of points that can be on at the same time depends on the ambient temperature, the external voltage, and the orientation of the module and DIN rail. The charts below show example thermal deratings for the module at 24VDC and 30VDC with the maximum output current per point.

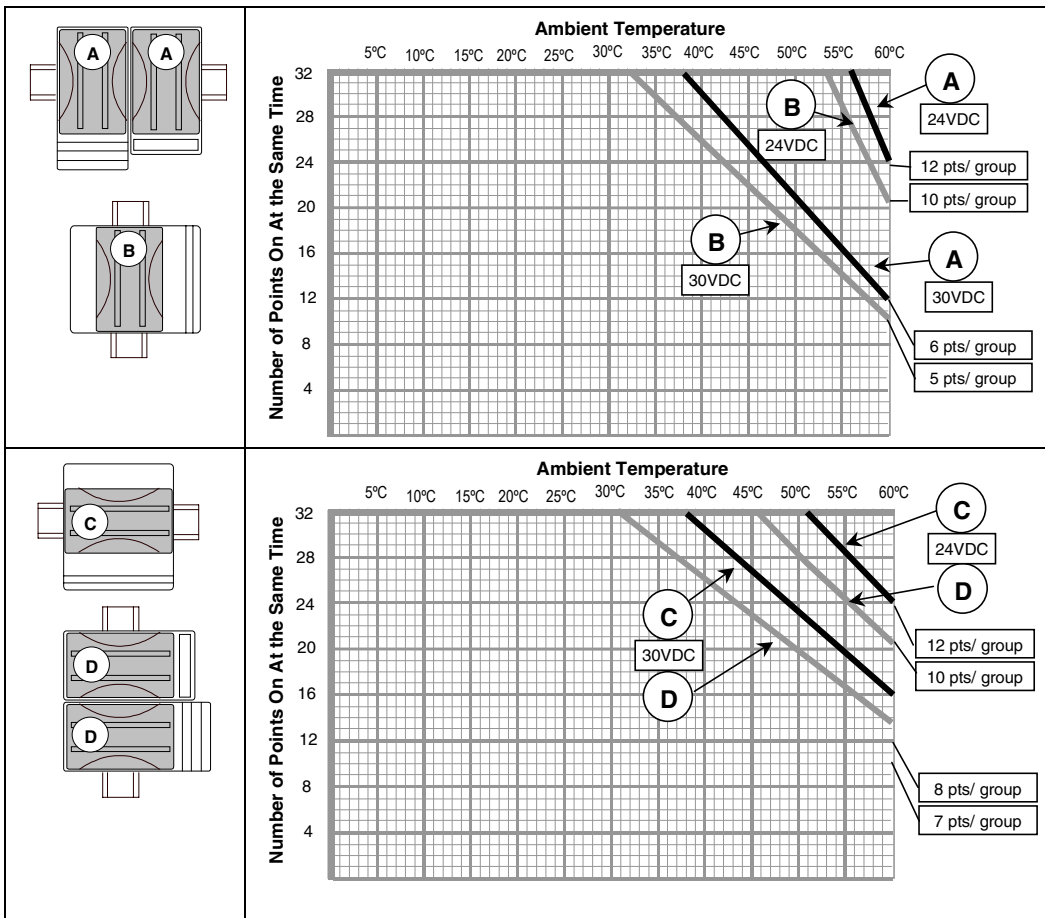

IC200MDL930 **Output Module, Relay 2.0 Amp Isolated Form A 8 Points**

Relay output module IC200MDL930 provides 8 individually-isolated Form A relay outputs. The contact is closed when the host CPU is active and the corresponding output logic bit is “1”.

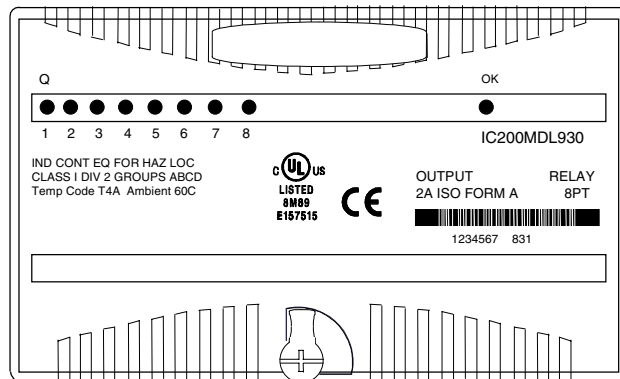

Power for module operation comes from the backplane. Loads must be powered by an external source.

Intelligent processing for this module is performed by the CPU or NIU. The module receives 8 bits of discrete output data.

LED Indicators

Individual green logic-side LEDs indicate the On/Off status of each output point. Output LEDs are logic-driven and independent of the load conditions.

The green OK LED is ON when backplane power is present to the module.

IC200MDL930

Output Module, Relay 2.0 Amp Isolated Form A 8 Points

Module Specifications

Module Characteristics	
Points	8 individually isolated Form A relay outputs
Module ID	FFFF8040
Isolation:	
User input to logic (optical) and to frame ground	250VAC continuous; 1500VAC for 1 minute
Group to group	Not applicable
Point to point	250VAC continuous; 1500VAC for 1 minute
LED indicators	One LED per point shows individual point ON/OFF status OK LED indicates backplane power is present
Backplane current consumption	5V output: 245mA maximum. See graph
External power supply	0 to 125VDC, 5/24/125VDC nominal 0 to 265VAC (47 to 63Hz), 120/240VAC nominal
Thermal derating	None
Output Characteristics	
Output voltage	0 to 125VDC, 5/24/125VDC nominal 0 to 265VAC (47 to 63Hz), 120/240VAC nominal
Output voltage drop	0.3V maximum
Load current	10mA per point minimum 2.0A for 5 to 265VAC maximum (resistive) 2.0A for 5 to 30VDC maximum (resistive) 0.2A for 31 to 125VDC maximum (resistive)
Output leakage current	Not applicable (open contact)
On response time	10ms maximum
Off response time	10ms maximum
Protection	No internal fuses or snubbers
Switching frequency	20 cycles per minute (inductive load)
Relay type	Fixed coil, moving armature
Contact type	Silver alloy
Contact life	See appendix B

IC200MDL930
Output Module, Relay 2.0 Amp Isolated Form A 8 Points

Field Wiring

Terminal	Connection	Terminal	Connection
A1	Output 1-1	B1	No connection
A2	Output 1-2	B2	No connection
A3	Output 2-1	B3	No connection
A4	Output 2-2	B4	No connection
A5	Output 3-1	B5	No connection
A6	Output 3-2	B6	No connection
A7	Output 4-1	B7	No connection
A8	Output 4-2	B8	No connection
A9	Output 5-1	B9	No connection
A10	Output 5-2	B10	No connection
A11	Output 6-1	B11	No connection
A12	Output 6-2	B12	No connection
A13	Output 7-1	B13	No connection
A14	Output 7-2	B14	No connection
A15	Output 8-1	B15	No connection
A16	Output 8-2	B16	No connection
A17	No connection	B17	No connection
A18	No connection	B18	No connection

Outputs are individually isolated. If additional bussed terminals are needed, the B terminals can be made available by using a shorting bar. The shorting bar has a maximum current-carrying capacity of 2 Amps per point. See chapter 2 for additional information about using the shorting bar.

When wiring outputs to inductive loads, use of external suppression circuits is recommended. See chapter 2, "Installing Wiring for I/O Devices-Wiring to Inductive Loads" for more information.

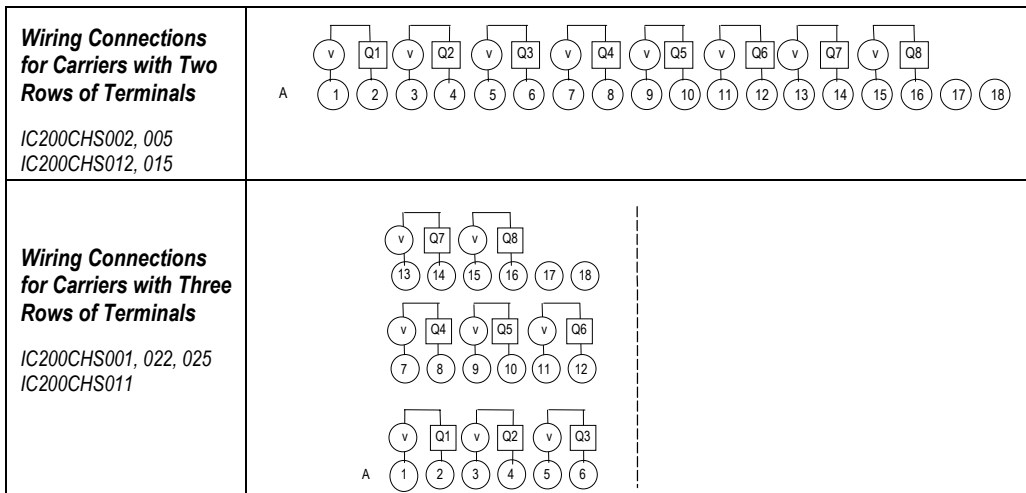

IC200MDL930

Output Module, Relay 2.0 Amp Isolated Form A 8 Points

Backplane Power Drain per Point

The module's backplane 5 volt power requirement increases as the number of points that are simultaneously on increases. The chart below shows the relationship between the number of points on and the maximum current required.

$$\text{mA} = 13 + (28 \times \text{number of points on})$$

Maximum Current Drawn from Backplane (mA)

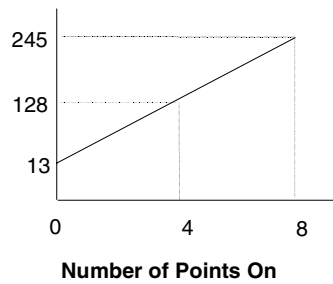

IC200MDL940 **Output Module, Relay 2.0 Amp, Isolated Form A 16 Points**

Relay Output Module IC200MDL940 provides 16 individually-isolated Form A relay outputs. The contact is closed when the host CPU is active and the corresponding output logic bit is “1”.

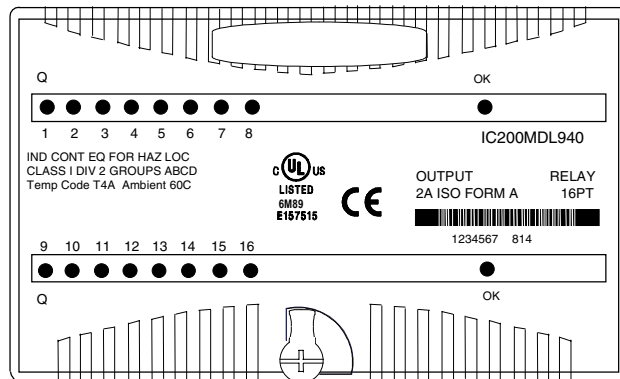

Power for module operation comes from the backplane. Loads must be powered by an external source.

Intelligent processing for this module is performed by the CPU or NIU. The module receives 16 bits of discrete output data.

LED Indicators

Individual green logic-side LEDs indicate the On/Off status of each output point. The output LEDs are logic-driven and independent of load conditions.

The green OK LED is ON when backplane power is present to the module.

IC200MDL940
Output Module, Relay 2.0 Amp, Isolated Form A 16 Points

Module Specifications

Module Characteristics	
Points	16 individually isolated Form A relay outputs
Module ID	80408040
Isolation:	
User input to logic (optical) or frame ground	250VAC continuous; 1500VAC for 1 minute
Group to group	250VAC continuous; 1500VAC for 1 minute
Point to point	250VAC continuous; 1500VAC for 1 minute
LED indicators	One LED per point shows individual point ON/OFF state OK LED indicates backplane power is present
Backplane current consumption	5V output: 490mA maximum
External power supply	0 to 125VDC, 5/24/125VDC nominal 0 to 265VAC (47 to 63Hz), 120/240VAC nominal
Thermal derating	None
Output Characteristics	
Output voltage	0 to 125VDC, 5/24/125VDC nominal 0 to 265VAC (47 to 63Hz), 120/240VAC nominal
Output voltage drop	0.3V maximum
Load current	10mA per point minimum 2.0A for 5 to 265VAC maximum (resistive) 2.0A for 5 to 30 VDC maximum (resistive) 0.2A for 31 to 125 VDC maximum (resistive)
Output leakage current	Not applicable (open contact)
On response time	10ms maximum
Off response time	10ms maximum
Protection	No internal fuses or snubbers
Switching frequency	20 cycles per minute (inductive load)
Relay type	Fixed coil, moving armature
Contact type	Silver alloy
Contact life	See appendix D

IC200MDL940
Output Module, Relay 2.0 Amp, Isolated Form A 16 Points

Field Wiring

Terminal	Connection	Terminal	Connection
A1	Output 1-1	B1	Output 9-1
A2	Output 1-2	B2	Output 9-2
A3	Output 2-1	B3	Output 10-1
A4	Output 2-2	B4	Output 10-2
A5	Output 3-1	B5	Output 11-1
A6	Output 3-2	B6	Output 11-2
A7	Output 4-1	B7	Output 12-1
A8	Output 4-2	B8	Output 12-2
A9	Output 5-1	B9	Output 13-1
A10	Output 5-2	B10	Output 13-2
A11	Output 6-1	B11	Output 14-1
A12	Output 6-2	B12	Output 14-2
A13	Output 7-1	B13	Output 15-1
A14	Output 7-2	B14	Output 15-2
A15	Output 8-1	B15	Output 16-1
A16	Output 8-2	B16	Output 16-2
A17	No connection	B17	No connection
A18	No connection	B18	No connection

Outputs are individually isolated. When wiring outputs to inductive loads, use of external suppression circuits is recommended. See chapter 2, "Installing Wiring for I/O Devices-Wiring to Inductive Loads" for more information.

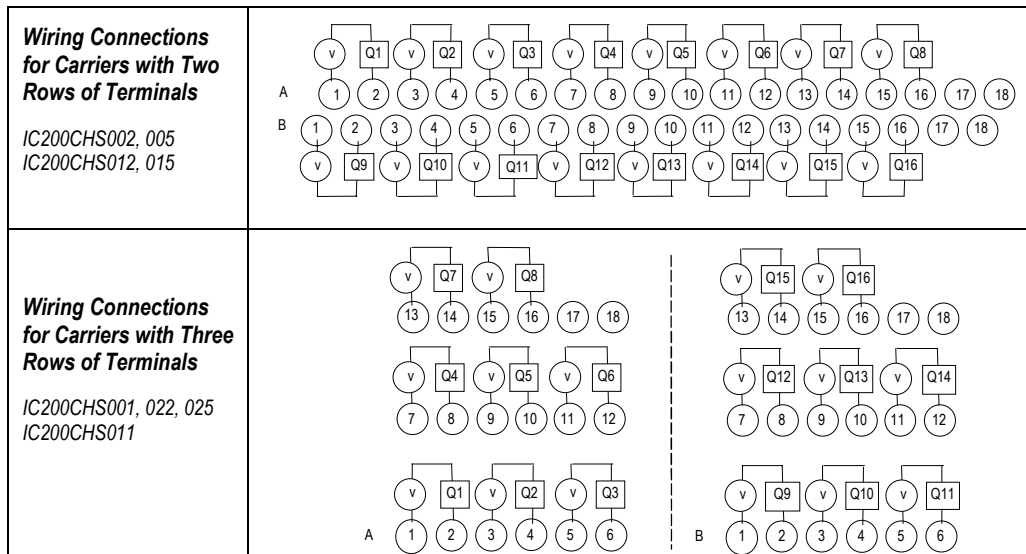

IC200MDL940

Output Module, Relay 2.0 Amp, Isolated Form A 16 Points

Backplane Power Drain per Point

The module's backplane 5 volt power requirement increases as the number of points that are simultaneously on increases. The chart below shows the relationship between the number of points on and the maximum current required.

$$\text{mA} = 13 + (28 \times \text{number of points on})$$

Maximum Current Drawn from Backplane (mA)

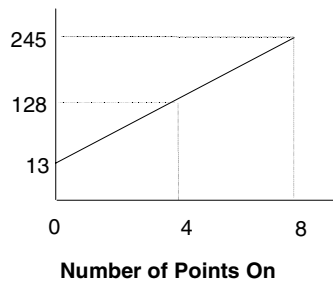

Chapter 9

Discrete Mixed Modules

This chapter describes discrete modules with both inputs and outputs. See chapter 13 for information about module IC200MDD841 (Mixed 24VDC Positive Logic Input 20 Point / Output 12 Point / 4 High Speed Counter, PWM, or Pulse Train points).

- IC200MDD840 Mixed Module, 24VDC Positive Logic Input 20 Points / Output Relay 2.0 Amp 12 Points
- IC200MDD842 Mixed Module, Output 24VDC Pos. Logic 0.5A Grouped w/ESCP 16 Points / Input 24VDC Pos/Neg Logic Grouped 16 Points
- IC200MDD843 Mixed Module, 24VDC Positive Logic Input Grouped 10 Points / Output Relay 2.0A per Point Grouped 6 Points
- IC200MDD844 Mixed Module, Output 12/24VDC Pos. Logic 0.5A 16 Points / Input 24 VDC Pos/Neg Logic Grouped 16 Points
- IC200MDD845 Mixed Module, Output Relay 2.0A Isolated 8 Points / Input 24VDC Pos/Neg Logic Grouped 16 Points
- IC200MDD846 Mixed Module, Output Relay 2.0A per Pt Isolated 8 Points / Input 120VAC Grouped 8 Points
- IC200MDD847 Mixed Module, Output Relay 2.0A per Pt Isolated 8 Points / Input 240VAC Grouped 8 Points
- IC200MDD848 Mixed Module, Output 120VAC 0.5A per Pt Isolated 8 Points / Input 120VAC Grouped 8 Points
- IC200MDD849 Mixed Module Output Relay 2.0A per Pt Isolated 8 Points / Input 120VAC Isolated 8 Points
- IC200MDD850 Mixed Module, Output Relay 2.0A per Pt Isolated 8 Points / Input 240VAC Isolated 4 Points
- IC200MDD851 Mixed Module, Output 12/24VDC Positive Logic Grouped 16 Points / Input 5/12VDC Pos/Neg Logic Grouped 16 Points

IC200MDD840
Mixed Module, 24VDC Positive Logic Input 20 Points /
Output Relay 2.0 Amp 12 Points

Discrete input/output module IC200MDD840 provides 20 discrete inputs and 12 relay outputs. The inputs form two groups of 10 points. Inputs are positive logic or sourcing-type inputs; they receive current from devices and return the current on the common. The relay outputs form two groups of 6 points. Each output group can drive a maximum of 8 Amps.

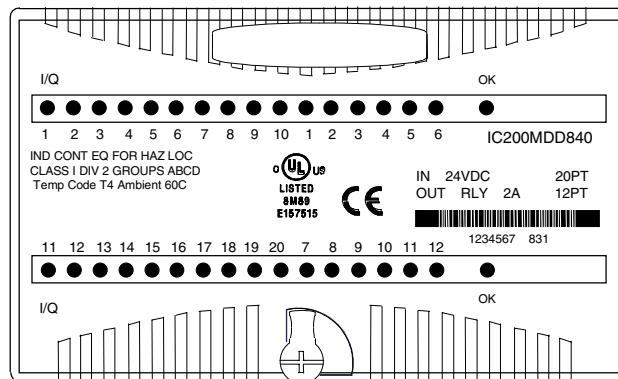

Power for module operation comes from the backplane. Output loads must be powered by an external source.

Intelligent processing for the module is performed by the CPU or NIU. The module provides 20 bits of discrete input data and receives 12 bits of discrete output data.

LED Indicators

Individual green LEDs indicate the on/off state of the output points and input points.

The output LEDs are logic-driven and independent of the load conditions.

The green OK LED is on when backplane power is present to the module.

Configuration Parameters

The module's basic input on/off response time is 0.5ms.

For some applications, it may be preferable to add additional filtering to compensate for conditions such as noise spikes or switch bounce. Input filter times of 0ms, 1.0ms, or 7.0ms are selectable via software configuration, for total response times of 0.5ms, 1.5ms, and 7.5ms respectively. The default is 1.0ms filter time (total response time is 1.5ms).

IC200MDD840
Mixed Module, 24VDC Positive Logic Input 20 Points /
Output Relay 2.0 Amp 12 Points

Module Specifications

Module Characteristics	
Points	20 positive DC inputs, two groups of 10 12 Form A relay outputs, two groups of 6
Module ID	80358035
Isolation:	
User input/output to logic (optical) and frame ground	250VAC continuous; 1500VAC for 1 minute
Group to group	250VAC continuous; 1500VAC for 1 minute
Point to point	None
LED indicators	One LED per point shows individual point on/off state OK LED indicates backplane power is present
Backplane current consumption	5V output: 375mA maximum
External power supply	0 to 125VDC, 5/24/125VDC nominal 0 to 265VAC (47 to 63Hz), 120/240VAC nominal
Thermal derating	None
Configuration parameters	Input response time
Input Characteristics	
Input voltage	0 to +30VDC, +24VDC nominal
On state voltage	+15 to +30VDC
Off state voltage	0 to +5VDC
On state current	2.0 to 5.5mA
Off state current	0 to 0.5mA
On response time	0.5ms maximum
Off response time	
Configurable filter time	0ms, 1.0ms (default), or 7.0ms
Input impedance	10kOhms, maximum
Output Characteristics	
Output voltage	0 to 125VDC, 5/24/125VDC nominal 0 or 265VAC (47 to 63Hz), 120/240VAC nominal
Output voltage drop	0.3V maximum
Load current	10mA per point minimum 2.0A for 5 to 265VAC maximum (resistive), 8.0A max. per group 2.0A for 5 to 30VDC maximum (resistive), 8.0A max. per group 0.2 A for 31 to 125VDC maximum (resistive)
Output leakage current	Not applicable (open contact)
On response time	10ms maximum
Off response time	10ms maximum
Protection	No internal fuses or snubbers
Switching frequency	20 cycles per minute (inductive load)
Relay type	Fixed coil, moving armature
Contact type	Silver alloy
Contact life	See appendix B

IC200MDD840
Mixed Module, 24VDC Positive Logic Input 20 Points /
Output Relay 2.0 Amp 12 Points

Field Wiring

Terminal	Connection	Terminal	Connection
A1	Input 1	B1	Input 11
A2	Input 2	B2	Input 12
A3	Input 3	B3	Input 13
A4	Input 4	B4	Input 14
A5	Input 5	B5	Input 15
A6	Input 6	B6	Input 16
A7	Input 7	B7	Input 17
A8	Input 8	B8	Input 18
A9	Input 9	B9	Input 19
A10	Input 10	B10	Input 20
A11	Output 1	B11	Output 7
A12	Output 2	B12	Output 8
A13	Output 3	B13	Output 9
A14	Output 4	B14	Output 10
A15	Output 5	B15	Output 11
A16	Output 6	B16	Output 12
A17	Inputs 1-10 Common	B17	Inputs 11-20 Common
A18	Outputs 1-6 Common	B18	Outputs 7-12 Common

When wiring outputs to inductive loads, use of external suppression circuits is recommended. See chapter 2, "Installing Wiring for I/O Devices-Wiring to Inductive Loads" for more information.

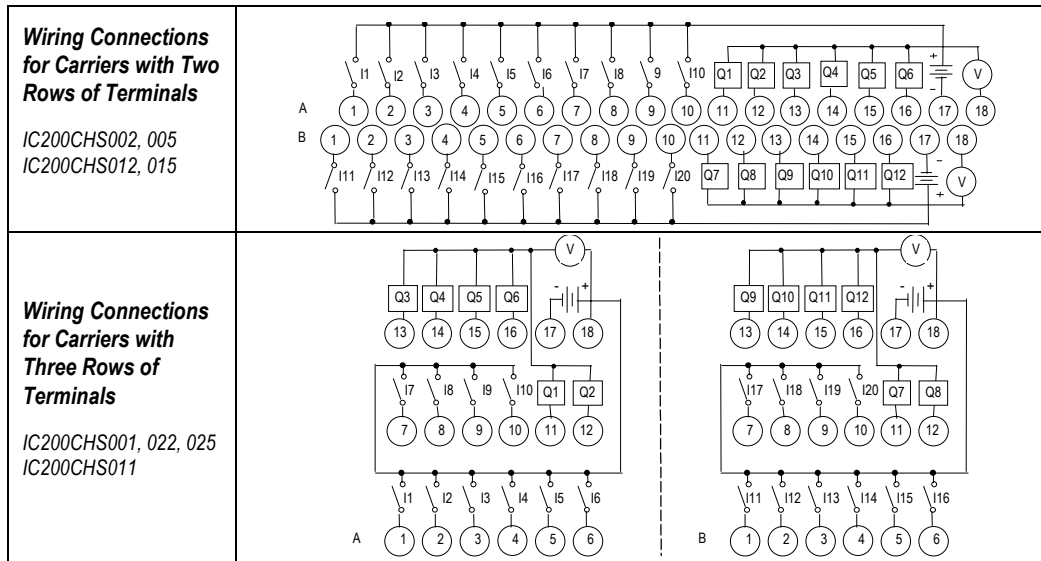

IC200MDD840
Mixed Module, 24VDC Positive Logic Input 20 Points /
Output Relay 2.0 Amp 12 Points

Backplane Power Drain per Point

The module's backplane 5 volt power requirement increases as the number of points that are simultaneously on increases. The chart below shows the relationship between the number of points on and the maximum current required.

$$\text{mA} = 40 + (28 \times \text{number of output points on})$$

Maximum Current Drawn from Backplane (mA)

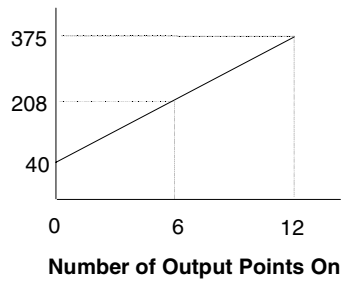

IC200MDD842

**Mixed Module, Output 24VDC Pos. Logic 0.5A Grouped w/ESCP 16 Points
/ Input 24VDC Pos/Neg Logic Grouped 16 Points**

Discrete input/output module IC200MDD842 provides one group of 16 discrete outputs w/ESCP and two groups of 8 discrete inputs. The outputs are positive or sourcing type outputs. Each point has electronic over-current protection and short circuit protection, and generates a fault if either condition exists. They switch the loads to the positive side of the DC supply and thus supply current to the loads. Inputs in each group can be either positive logic inputs that receive current from input devices and return the current on the common, or negative-logic inputs that receive current from the common and return current to the input device. Input devices are connected between the input terminals and common terminals.

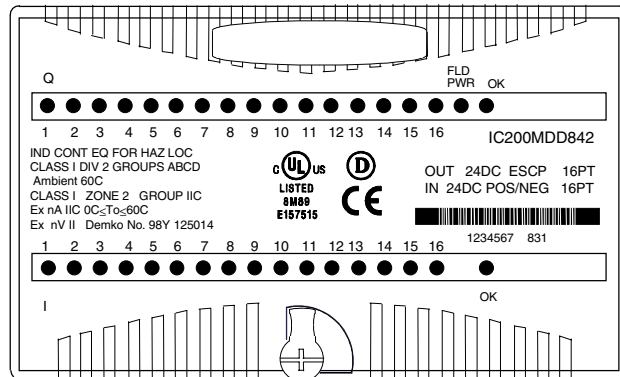

Note: Negative-logic functionality requires module version IC200MDD842B or higher.

An external DC power supply must be provided to switch power to the loads. Intelligent processing for this module is performed by the CPU or NIU. The module provides 16 bits of discrete input data and receives 16 bits of discrete output data.

LED Indicators

Individual green LEDs indicate the on/off state of the output points and input points. Operation of the output LEDs is dependent on field power, but independent of load conditions. Individual amber LEDs indicate overload conditions on each output point. The green FLD PWR LED is on when field power is applied to the module. The green OK LED is on when backplane power is present to the module.

Configuration Parameters

The module's basic input on/off response time is 0.5ms. For some applications, it may be preferable to add additional filtering to compensate for conditions such as noise spikes or switch bounce. Input filter times of 0ms, 1.0ms, or 7.0ms are selectable via software configuration, for total response times of 0.5ms, 1.5ms, and 7.5ms respectively. The default is 1.0ms filter time (total response time is 1.5ms).

Diagnostics

The module reports the presence of any overloaded points to the system on a per-module basis. Amber LEDs indicate the overload conditions on a per-point basis. Once the overload condition is removed, normal operation is resumed.

IC200MDD842
Mixed Module, Output 24VDC Pos. Logic 0.5A Grouped w/ESCP 16 Points
/ Input 24VDC Pos/Neg Logic Grouped 16 Points

Module Specifications

Module Characteristics	
Points	1 group of 16 outputs 2 groups of 8 inputs
Module ID	80088080
Isolation: User input to logic (optical) and to frame ground Group to group Point to point	250VAC continuous; 1500VAC for 1 minute 250VAC continuous; 1500VAC for 1 minute None
LED indicators	One green LED per point shows individual point on/off state. One amber LED per point shows individual point overloads for outputs. FLD PWR LED indicates field power is present OK LED indicates backplane power is present
Backplane current consumption	5V output: 100mA maximum
External power supply	+18 to +30VDC, +24VDC nominal
Thermal derating	See diagram
Configuration parameters	Input response time
Input Characteristics	
Input voltage	0 to +30VDC, +24VDC nominal
On state voltage	+15 to +30VDC
Off state voltage	0 to +5VDC
On state current	2.0 to 5.5mA
Off state current	0 to 0.5mA
On response time	0.5ms maximum
Off response time	
Additional configurable filter time	0 ms, 1.0ms (default), or 7.0ms
Input impedance	10kOhms maximum
Output Characteristics	
Output voltage	+18 to +30VDC, +24VDC nominal
Output voltage drop	0.5V maximum
Steady-state overcurrent trip point	1.6A typical, 0.7A to 2.5A maximum range
Load current	0.5 Amp at 30VDC maximum (resistive) 2.0 Amps maximum for 100ms inrush
Output leakage current	0.5mA at 30VDC maximum
On response time	0.5ms maximum
Off response time	0.5ms maximum
Protection (each output)	Short circuit protection, overcurrent protection, free-wheeling diodes

IC200MDD842**Mixed Module, Output 24VDC Pos. Logic 0.5A Grouped w/ESCP 16 Points
/ Input 24VDC Pos/Neg Logic Grouped 16 Points****External Power Supply Requirements**

The external power supply used to power the loads must provide sufficient field power for the module during short circuit events. When a load is shorted, an inadequate external power supply may allow field power to drop below the specified operating range, causing misoperation of the module. The external power supply must be capable of providing short circuit energy without degradation of output voltage levels. The amount of energy required depends on the number of simultaneously-short-circuited points that might occur. Refer to power supply short circuit operation specifications when selecting the power supply to be used with the loads.

Local energy storage (either batteries or capacitors) can be used to compensate for insufficient power supply characteristics. Additional best practices including minimizing wiring resistance from the external power supply to the module must be observed.

IC200MDD842

**Mixed Module, Output 24VDC Pos. Logic 0.5A Grouped w/ESCP 16 Points
/ Input 24VDC Pos/Neg Logic Grouped 16 Points**

Field Wiring

Terminal	Connection	Terminal	Connection
A1	Output 1	B1	Input 1
A2	Output 2	B2	Input 2
A3	Output 3	B3	Input 3
A4	Output 4	B4	Input 4
A5	Output 5	B5	Input 5
A6	Output 6	B6	Input 6
A7	Output 7	B7	Input 7
A8	Output 8	B8	Input 8
A9	Output 9	B9	Input 9
A10	Output 10	B10	Input 10
A11	Output 11	B11	Input 11
A12	Output 12	B12	Input 12
A13	Output 13	B13	Input 13
A14	Output 14	B14	Input 14
A15	Output 15	B15	Input 15
A16	Output 16	B16	Input 16
A17	DC -	B17	Inputs 1-8 Common
A18	DC +	B18	Inputs 9-16 Common

The 16 outputs form one group with a DC+ and a DC- terminal. The 16 inputs form two groups of 8. Each group has a common return. Each group may be wired for positive or negative logic inputs. Note: Negative-logic functionality requires module version IC200MDD842B or higher. When wiring outputs to inductive loads, use of external suppression circuits is recommended. See chapter 2, "Installing Wiring for I/O Devices-Wiring to Inductive Loads" for more information.

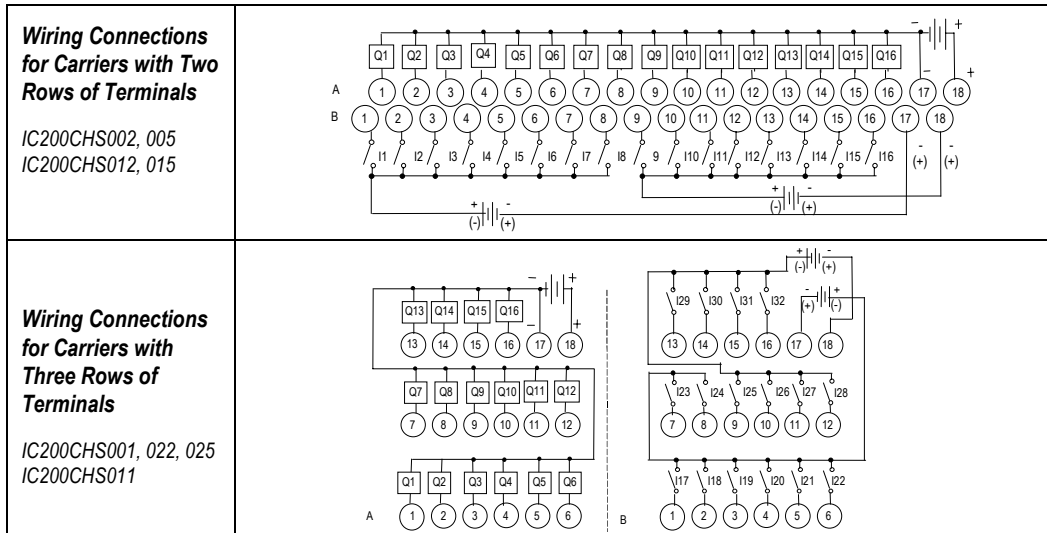

IC200MDD842
Mixed Module, Output 24VDC Pos. Logic 0.5A Grouped w/ESCP 16 Points
/ Input 24VDC Pos/Neg Logic Grouped 16 Points

Thermal Derating

The number of points that can be on at the same time depends on the ambient temperature, the external voltage, and the orientation of the module and DIN rail. The charts that follow show thermal deratings for this module at 24V and 30V. The shaded bands are temperature ranges that represent allowable combinations of inputs points for the indicated number of outputs points. All combinations of points are permissible at lower temperatures. The narrow white line within each range shows maximum temperature when the number of output points equals the number of input points that are on at the same time.

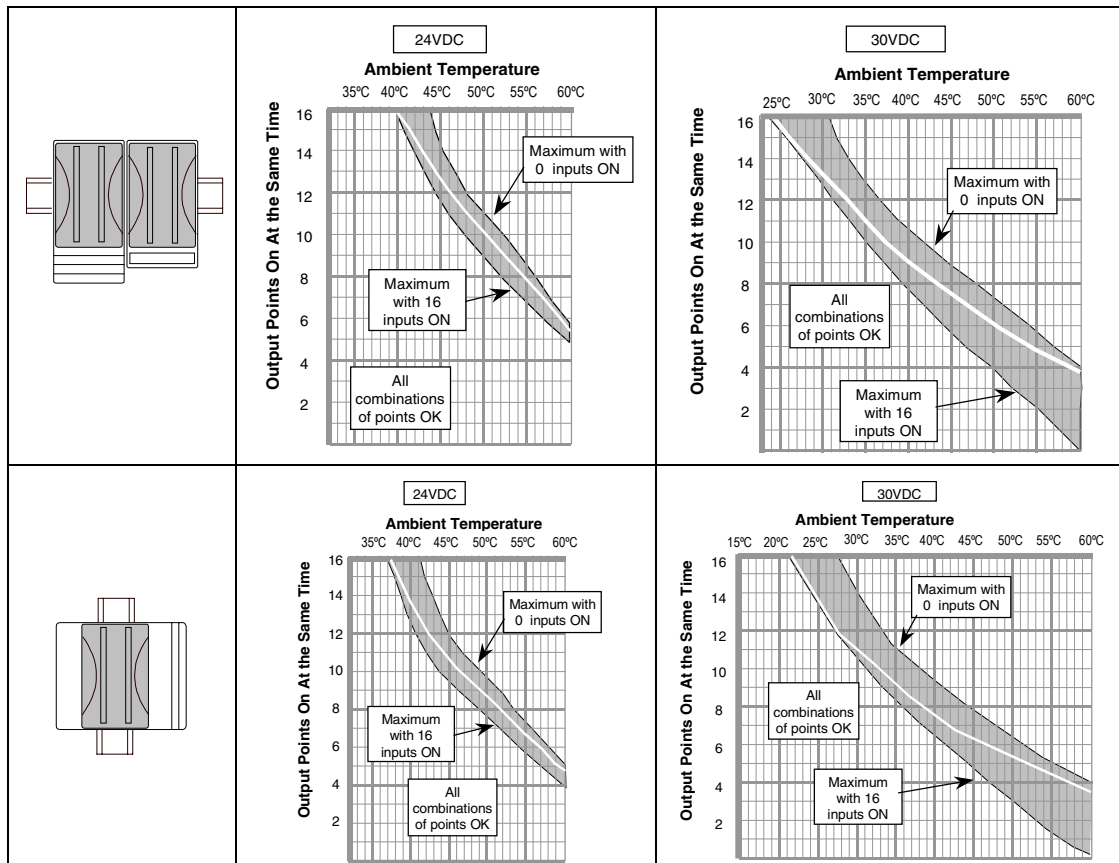

IC200MDD842

**Mixed Module, Output 24VDC Pos. Logic 0.5A Grouped w/ESCP 16 Points
/ Input 24VDC Pos/Neg Logic Grouped 16 Points**

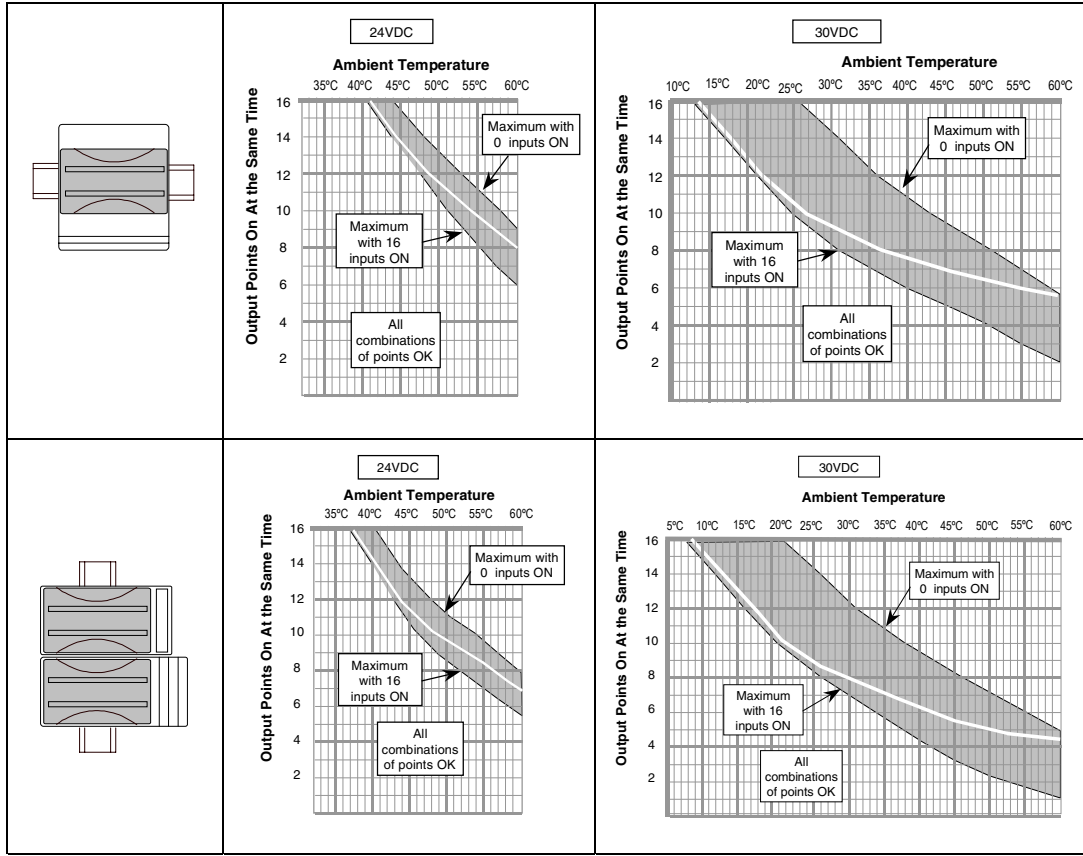

IC200MDD843

**Mixed Module, 24VDC Positive Logic Input Grouped 10 Points /
Output Relay 2.0A per Point Grouped 6 Points**

Discrete input/output module IC200MDD843 provides 10 discrete inputs and 6 relay outputs. The inputs form one group of 10 points. Inputs are positive logic or sourcing-type inputs; they receive current from input devices and return the current on the common. The relay outputs form one group of 6 points. The output group can drive a maximum of 8 Amps.

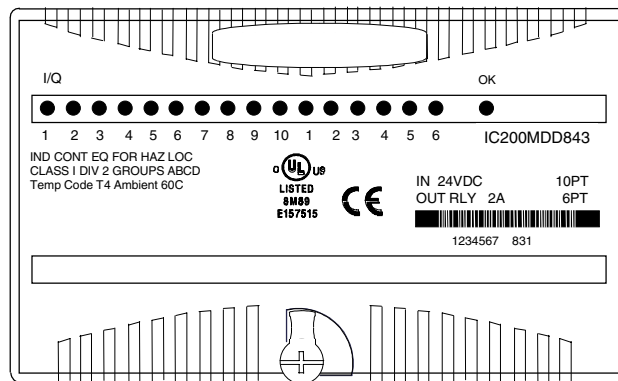

Power for module operation comes from the backplane. Loads must be powered by an external source.

Intelligent processing for the module is performed by the CPU or NIU. The module provides 10 bits of discrete input data and receives 6 bits of discrete output data.

LED Indicators

Individual green LEDs indicate the on/off state of the output points and input points.

The output LEDs are logic-driven and independent of the load conditions.

The green OK LED is on when backplane power is present to the module.

Configuration Parameters

The module's basic input on/off response time is 0.5ms.

For some applications, it may be preferable to add additional filtering to compensate for conditions such as noise spikes or switch bounce. Input filter times of 0ms, 1.0ms, or 7.0ms are selectable via software configuration, for total response times of 0.5ms, 1.5ms, and 7.5ms respectively. The default is 1.0ms filter time total (response time is 1.5ms).

IC200MDD843

**Mixed Module, 24VDC Positive Logic Input Grouped 10 Points /
Output Relay 2.0A per Point Grouped 6 Points**

Module Specifications

Module Characteristics	
Points	10 Positive DC Inputs, one group, 6 Form A Relay Outputs, one group
Module ID	FFFF8035
Isolation: User input/output to logic (optical) and frame ground	250VAC continuous; 1500VAC for 1 minute
Group to group	250VAC continuous; 1500VAC for 1 minute
Point to point	None
LED indicators	One LED per point shows individual point on/off state OK LED indicates backplane power is present
Backplane current consumption	5V output: 190mA maximum
External power supply	0 to 125VDC, 5/24/125VDC nominal 0 to 265VAC (47 to 63Hz), 120/240VAC nominal
Thermal derating	None
Configuration parameters	Input response time
Input Characteristics	
Input voltage	0 to +30VDC, +24VDC nominal
On state voltage	+15.0 to +30.0 VDC
Off state voltage	0 to +5.0 VDC
On state current	2.0 to 5.5mA
Off state current	0 to 0.5mA
On response time	0.5ms maximum
Off response time	
Configurable filter time	0ms, 1.0ms (default), or 7.0ms
Input impedance	10kOhms maximum
Output Characteristics	
Output voltage	0 to 125VDC, 5/24/125VDC nominal 0 to 265VAC (47 to 63Hz), 120/240VAC nominal
Output voltage drop	0.3V maximum
Load current	10mA per point minimum, 8.0A maximum per module 2.0 Amps for 5 to 265VAC maximum (resistive) 2.0 Amps for 5 to 30 VDC maximum (resistive) 0.2 Amp for 31 to 125 VDC maximum (resistive)
Output leakage current	Not applicable (open contact)
On response time	10ms maximum
Off response time	10ms maximum
Protection	No internal fuses or snubbers.
Switching frequency	20 cycles per minute (inductive load)
Relay type	Fixed coil, moving armature
Contact type	Silver alloy
Contact life	See appendix B

IC200MDD843
Mixed Module, 24VDC Positive Logic Input Grouped 10 Points /
Output Relay 2.0A per Point Grouped 6 Points

Field Wiring

Terminal	Connection	Terminal	Connection
A1	Input 1	B1	No connection
A2	Input 2	B2	No connection
A3	Input 3	B3	No connection
A4	Input 4	B4	No connection
A5	Input 5	B5	No connection
A6	Input 6	B6	No connection
A7	Input 7	B7	No connection
A8	Input 8	B8	No connection
A9	Input 9	B9	No connection
A10	Input 10	B10	No connection
A11	Output 1	B11	No connection
A12	Output 2	B12	No connection
A13	Output 3	B13	No connection
A14	Output 4	B14	No connection
A15	Output 5	B15	No connection
A16	Output 6	B16	No connection
A17	Inputs 1-10 Common	B17	No connection
A18	Outputs 1-6 Common	B18	No connection

If additional bussed terminals are needed, the B terminals can be made available by using a shorting bar. The shorting bar has a maximum current-carrying capacity of 2 Amps per point. See chapter 2 for additional information about using the shorting bar. When wiring outputs to inductive loads, use of external suppression circuits is recommended. See chapter 2, "Installing Wiring for I/O Devices-Wiring to Inductive Loads" for more information.

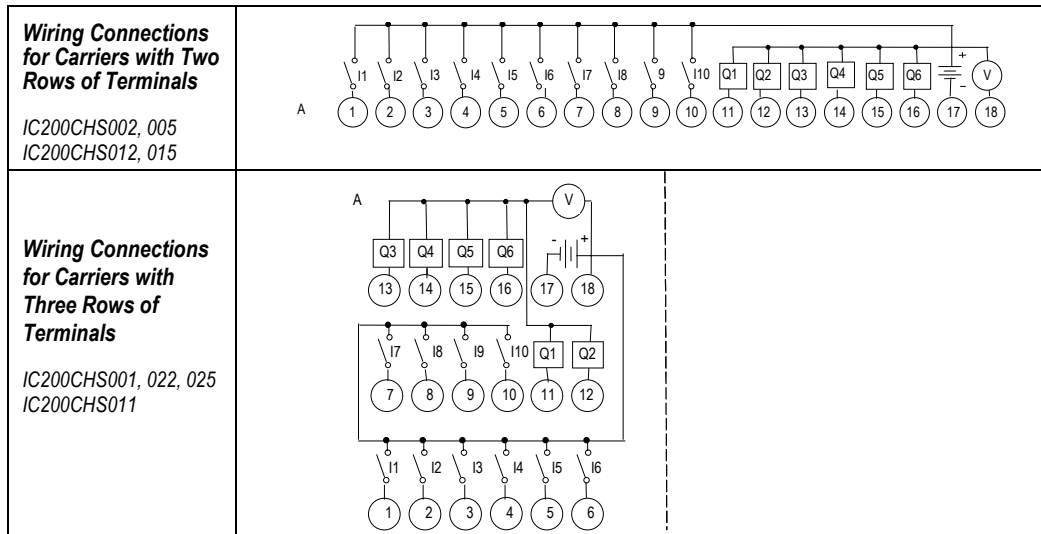

IC200MDD843

**Mixed Module, 24VDC Positive Logic Input Grouped 10 Points /
Output Relay 2.0A per Point Grouped 6 Points**

Backplane Power Drain per Point

The module's backplane 5 volt power requirement increases as the number of points that are simultaneously on increases. The chart below shows the relationship between the number of points on and the maximum current required.

$$\text{mA} = 40 + (28 \times \text{number of output points on})$$

Maximum Current Drawn from Backplane (mA)

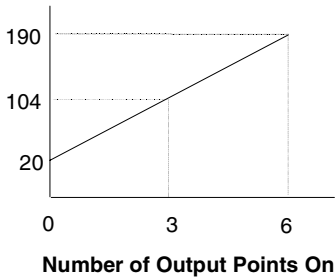

IC200MDD844

**Mixed Module, Output 12/24VDC Pos. Logic 0.5A 16 Points
/ Input 24 VDC Pos/Neg Logic Grouped 16 Points**

Discrete input/output module IC200MDD844 provides one group of 16 discrete outputs and two groups of 8 discrete inputs. The outputs are positive or sourcing type outputs. They switch the loads to the positive side of the DC supply and thus supply current to the loads. Inputs are positive logic; they receive current from input devices and return the current on the common. Input devices are connected between the input terminals and common terminals.

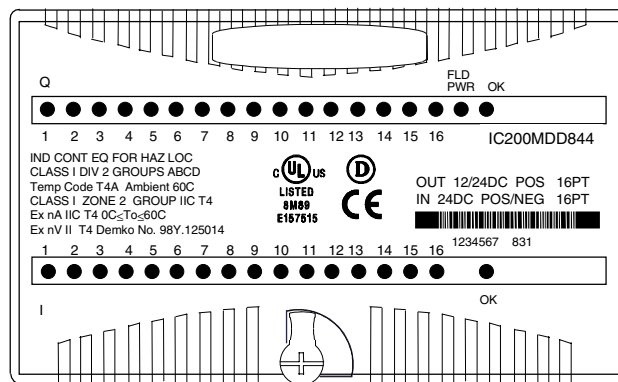

Note: Negative logic input functionality and 12V output functionality require module version IC200MDD844C or higher.

An external DC power supply must be provided to switch power to the loads.

Intelligent processing for this module is performed by the CPU or NIU. The module provides 16 bits of discrete input data and receives 16 bits of discrete output data.

LED Indicators

Individual green LEDs indicate the on/off state of the output points and input points. Operation of the output LEDs is dependent on field power, but independent of load conditions.

The green FLD PWR LED is on when field power is applied to the module.

The green OK LED is on when backplane power is present to the module.

Configuration Parameters

The module's basic input on/off response time is 0.5ms.

For some applications, it may be preferable to add additional filtering to compensate for conditions such as noise spikes or switch bounce. Input filter times of 0ms, 1.0ms, or 7.0ms are selectable via software configuration, for total response times of 0.5ms, 1.5ms, and 7.5ms respectively. The default is 1.0ms filter time (total response time is 1.5ms).

IC200MDD844

**Mixed Module, Output 12/24VDC Pos. Logic 0.5A 16 Points
/ Input 24 VDC Pos/Neg Logic Grouped 16 Points**

Module Specifications

Module Characteristics	
Points	1 group of 16 outputs 2 groups of 8 inputs
Module ID	80088080
Isolation:	
User input to logic (optical) and to frame ground	250VAC continuous; 1500VAC for 1 minute
Group to group	250VAC continuous; 1500VAC for 1 minute
Point to point	None
LED indicators	One LED per point shows individual point on/off state FLD PWR LED indicates field power is present OK LED indicates backplane power is present
Backplane current consumption	5V output: 70mA maximum
External power supply	+10.2 to +30VDC, +12/24VDC nominal
Thermal derating	See diagram
Configuration parameters	Input response time
Input Characteristics	
Input voltage	0 to +30VDC, +24VDC nominal
On state voltage	+15 to +30VDC
Off state voltage	0 to +5VDC
On state current	2.0 to 5.5mA
Off state current	0 to 0.5mA
On response time	0.5ms maximum
Off response time	
Configurable filter time	0 ms, 1.0ms (default), or 7.0ms
Input impedance	10kOhms maximum
Output Characteristics	
Output voltage	+10.2 to +30VDC, +12/24VDC nominal
Output voltage drop	0.3V
Load current	0.5 Amp at 30VDC maximum (resistive) 2.0 Amps maximum for 100ms inrush
Output leakage current	0.5mA at 30VDC maximum
On response time	0.2ms maximum
Off response time	1.0ms maximum
Protection	No internal fuses

IC200MDD844
Mixed Module, Output 12/24VDC Pos. Logic 0.5A 16 Points
/ Input 24 VDC Pos/Neg Logic Grouped 16 Points

Field Wiring

Terminal	Connection	Terminal	Connection
A1	Output 1	B1	Input 1
A2	Output 2	B2	Input 2
A3	Output 3	B3	Input 3
A4	Output 4	B4	Input 4
A5	Output 5	B5	Input 5
A6	Output 6	B6	Input 6
A7	Output 7	B7	Input 7
A8	Output 8	B8	Input 8
A9	Output 9	B9	Input 9
A10	Output 10	B10	Input 10
A11	Output 11	B11	Input 11
A12	Output 12	B12	Input 12
A13	Output 13	B13	Input 13
A14	Output 14	B14	Input 14
A15	Output 15	B15	Input 15
A16	Output 16	B16	Input 16
A17	DC -	B17	Inputs 1-8 Return
A18	DC +	B18	Inputs 9-16 Return

The 16 outputs form one group, each with a DC+ and a DC- terminal. The 16 inputs form two groups of 8. Each group has a common return. When wiring outputs to inductive loads, use of external suppression circuits is recommended. See chapter 2, "Installing Wiring for I/O Devices-Wiring to Inductive Loads" for more information.

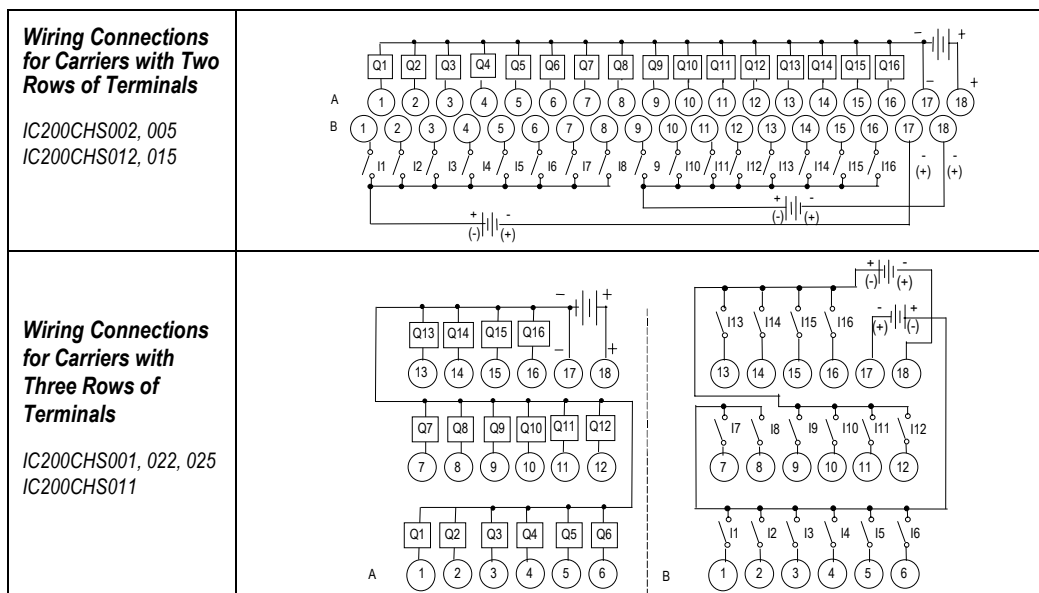

IC200MDD844

**Mixed Module, Output 12/24VDC Pos. Logic 0.5A 16 Points
/ Input 24 VDC Pos/Neg Logic Grouped 16 Points**

Thermal Derating

The number of points that can be on at the same time depends on the ambient temperature, the external voltage, and the orientation of the module and DIN rail. The charts that follow show thermal deratings for this module at 24V and 30V. The shaded bands are temperature ranges that represent allowable combinations of inputs points for the indicated number of outputs points. All combinations of points are permissible at lower temperatures. The narrow white line within each range shows maximum temperature when the number of output points equals the number of input points that are on at the same time.

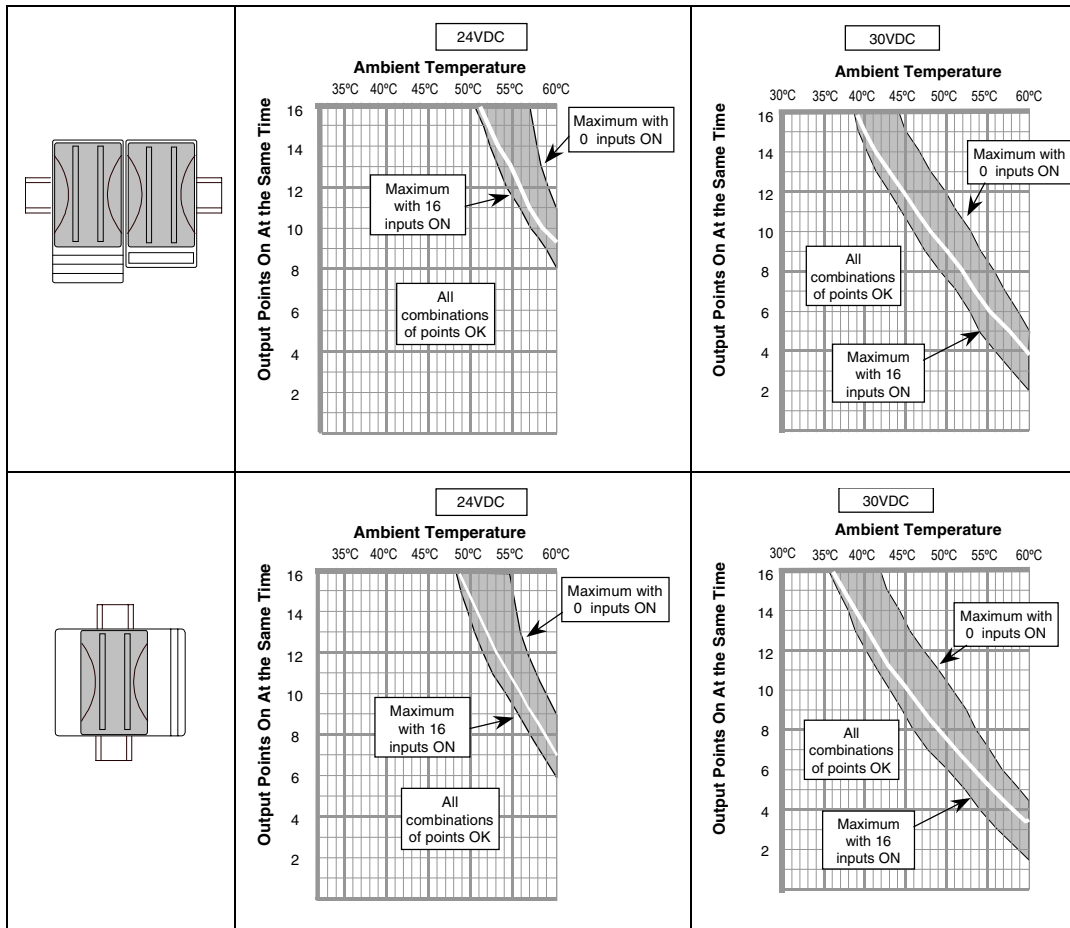

IC200MDD844
Mixed Module, Output 12/24VDC Pos. Logic 0.5A 16 Points
/ Input 24 VDC Pos/Neg Logic Grouped 16 Points

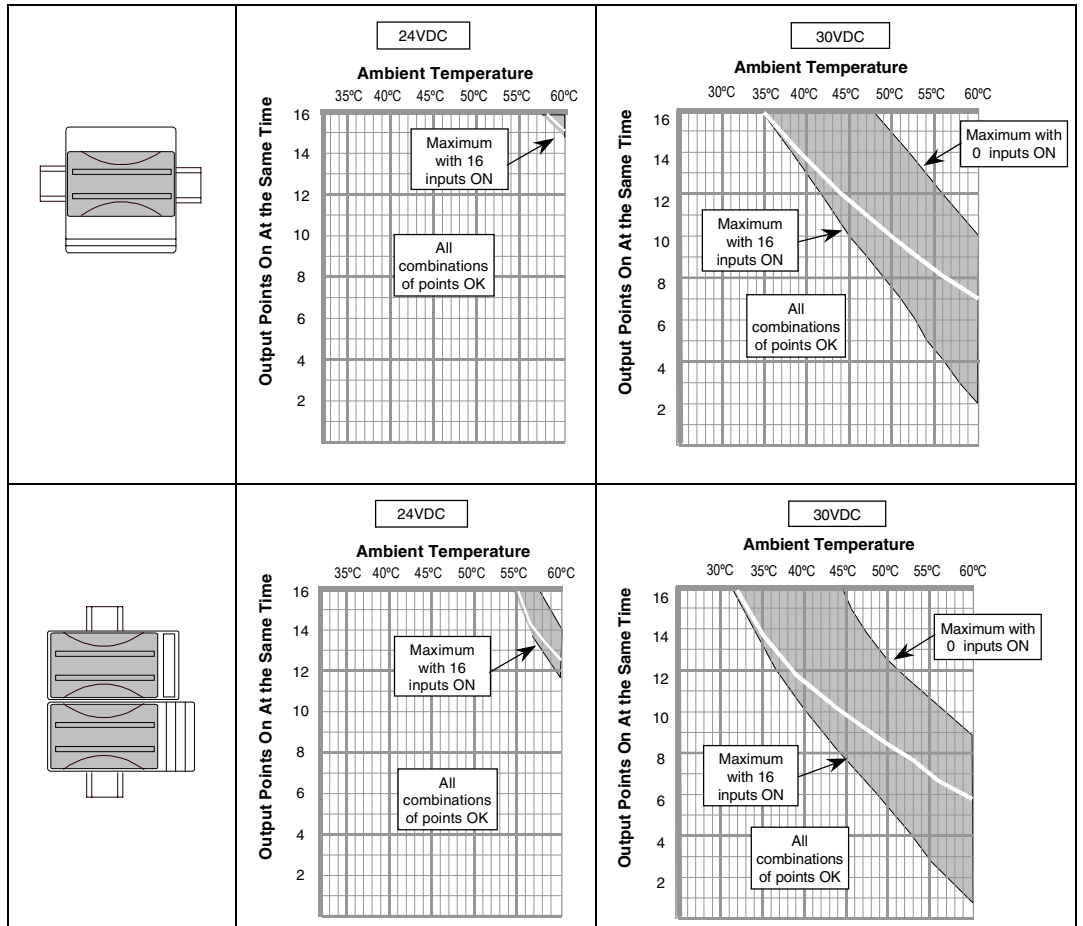

IC200MDD845
Mixed Module, Output Relay 2.0A Isolated 8 Points
/ Input 24VDC Pos/Neg Logic Grouped 16 Points

Discrete input/output module IC200MDD845 provides 8 individually-isolated Form A relay outputs and two groups of 8 discrete inputs. An output contact is closed when the host CPU is active and the corresponding output logic bit is “1”. Inputs in each group can be either positive logic inputs that receive current from input devices and return the current on the common, or negative-logic inputs that receive current from the common and return current to the input device. Input devices are connected between the input terminals and common terminals.

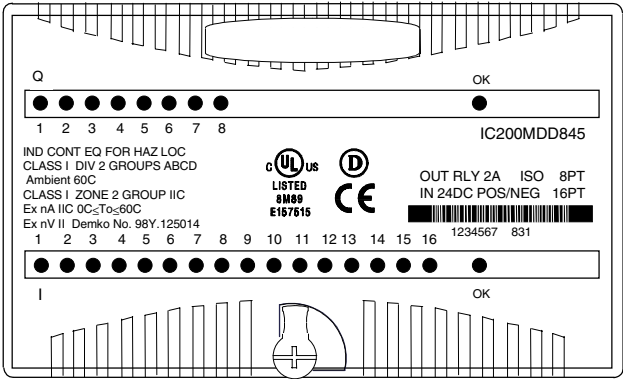

Note: Negative-logic functionality requires module version IC200MDD845C or higher.

Power for module operation comes from the backplane. Loads must be powered by an external source.

Intelligent processing for this module is performed by the CPU or NIU. The module provides 16 bits of discrete input data and receives 8 bits of discrete output data.

LED Indicators

Individual green LEDs indicate the On/Off states of the output points and input points. Operation of the output LEDs is logic driven and independent of the load conditions.

The green OK LEDs are on when backplane power is present to the module.

Configuration Parameters

The module’s basic input on/off response time is 0.5ms.

For some applications, it may be preferable to add additional filtering to compensate for conditions such as noise spikes or switch bounce. Input filter times of 0ms, 1.0ms, or 7.0ms are selectable via software configuration, for total response times of 0.5ms, 1.5ms, and 7.5ms respectively. The default is 1.0ms filter time (total response time is 1.5ms).

IC200MDD845
Mixed Module, Output Relay 2.0A Isolated 8 Points
/ Input 24VDC Pos/Neg Logic Grouped 16 Points

Module Specifications

Module Characteristics	
Points	1 group of 8 outputs 16 inputs (2 groups of 8)
Module ID	80088040
Isolation: User input to logic (optical) and to frame ground Group to group Point to point	250VAC continuous; 1500VAC for 1 minute 250VAC continuous; 1500VAC for 1 minute Outputs: 250VAC continuous; 1500VAC for 1 minute Inputs: none
LED indicators	One green LED per point shows individual point on/off state. OK LED indicates backplane power is present
Backplane current consumption	5V output: 270mA maximum. See graph
External power supply	0 to 125VDC, 5/24/125VDC nominal 0 to 265VAC (47 to 63Hz), 120/240VAC nominal
Thermal derating	See diagram
Configuration parameters	Input filter time
Input Characteristics	
Input voltage	0 to +30VDC, +24VDC nominal
On state voltage	+15 to +30VDC
Off state voltage	0 to +5VDC
On state current	2.0 to 5.5mA
Off state current	0 to 0.5mA
On response time	0.5ms maximum
Off response time	
Configurable filter time	0 ms, 1.0ms (default), or 7.0ms
Input impedance	10kOhms maximum
Output Characteristics	
Output voltage	0 to 125VDC, 5/24/125VDC nominal 0 to 265VAC (47 to 63Hz), 120/240VAC nominal
Output voltage drop	0.3V maximum
Load current	10mA per point minimum 2.0A for 5 to 265VAC maximum (resistive) 2.0A for 5 to 30VDC maximum (resistive) 0.2A for 31 to 125VDC maximum (resistive)
Output leakage current	Not applicable (open contact)
On response time	10ms maximum
Off response time	10ms maximum
Protection	No internal fuses or snubbers
Relay type	Fixed coil, moving armature
Contact type	Silver alloy
Contact life	See appendix B

IC200MDD845
Mixed Module, Output Relay 2.0A Isolated 8 Points
/ Input 24VDC Pos/Neg Logic Grouped 16 Points

Field Wiring

Terminal	Connection	Terminal	Connection
A1	Output 1-1	B1	Input 1
A2	Output 1-2	B2	Input 2
A3	Output 2-1	B3	Input 3
A4	Output 2-2	B4	Input 4
A5	Output 3-1	B5	Input 5
A6	Output 3-2	B6	Input 6
A7	Output 4-1	B7	Input 7
A8	Output 4-2	B8	Input 8
A9	Output 5-1	B9	Input 9
A10	Output 5-2	B10	Input 10
A11	Output 6-1	B11	Input 11
A12	Output 6-2	B12	Input 12
A13	Output 7-1	B13	Input 13
A14	Output 7-2	B14	Input 14
A15	Output 8-1	B15	Input 15
A16	Output 8-2	B16	Input 16
A17	No Connection	B17	Inputs 1-8 Common
A18	No Connection	B18	Inputs 9-16 Common

The outputs are individually-isolated. The 16 inputs form two groups of 8. Each group has a common return. Each group may be wired for positive or negative logic inputs. Note: Negative-logic functionality requires module version IC200MDD845C or higher. When wiring outputs to inductive loads, use of external suppression circuits is recommended. See chapter 2, "Installing Wiring for I/O Devices-Wiring to Inductive Loads" for more information.

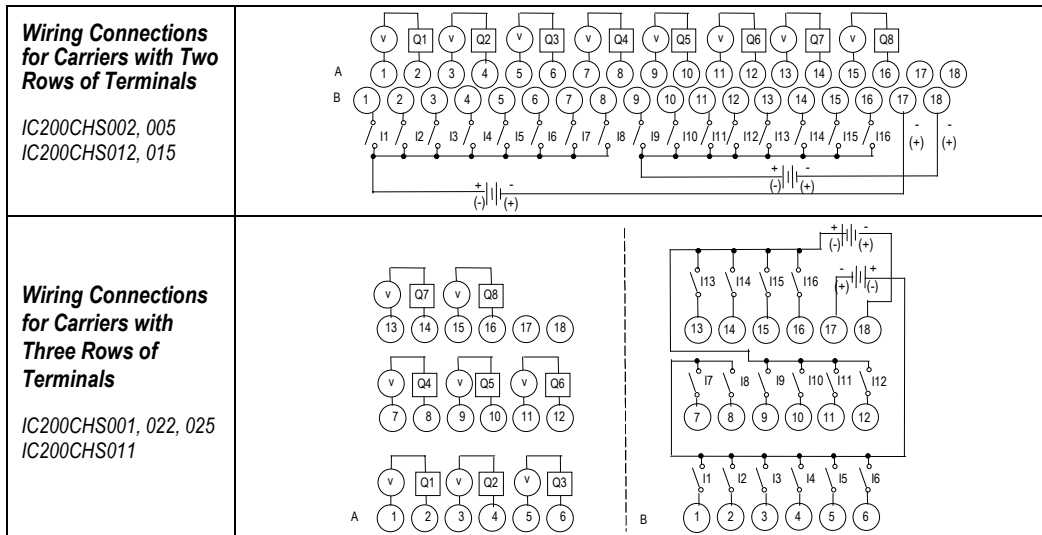

IC200MDD845
Mixed Module, Output Relay 2.0A Isolated 8 Points
/ Input 24VDC Pos/Neg Logic Grouped 16 Points

Backplane Power Drain per Point

The module's backplane 5 volt power requirement increases as the number of points that are simultaneously on increases. The chart below shows the relationship between the number of output points on and the maximum current required.

$$\text{mA} = 46 + (28 \times \text{number of output points on})$$

Maximum Current Drawn from Backplane (mA)

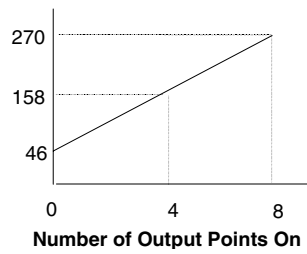

IC200MDD845
Mixed Module, Output Relay 2.0A Isolated 8 Points
/ Input 24VDC Pos/Neg Logic Grouped 16 Points

Thermal Derating

The number of points that can be on at the same time depends on the ambient temperature, the external voltage, and the orientation of the module and DIN rail. The charts that follow show thermal deratings for this module at 24V and 30V. The shaded bands are temperature ranges that represent allowable combinations of inputs points for the indicated number of outputs points. All combinations of points are permissible at lower temperatures. The narrow white line within each range shows maximum temperature with two inputs on for each output (for example: 3 outputs and 6 inputs).

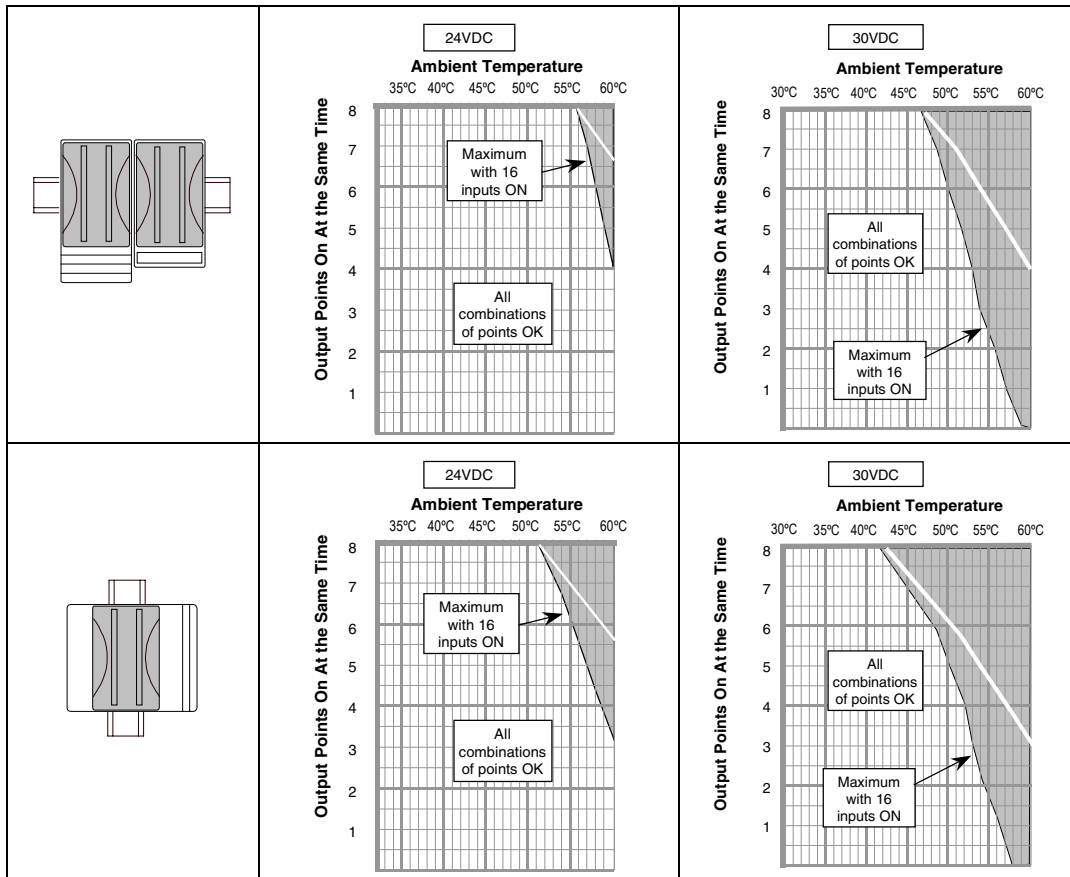

IC200MDD845
Mixed Module, Output Relay 2.0A Isolated 8 Points
/ Input 24VDC Pos/Neg Logic Grouped 16 Points

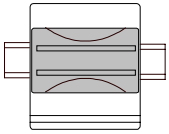
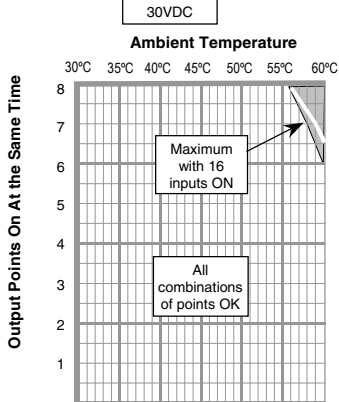
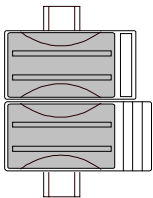
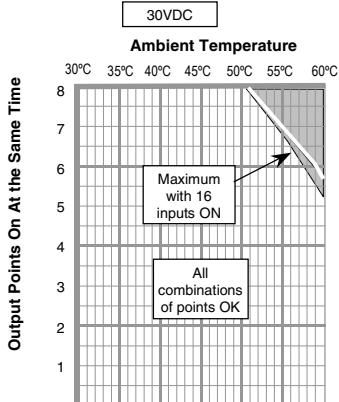
	<p>No derating at 24VDC.</p>	<p>30VDC</p> <p>Ambient Temperature</p> 
	<p>No derating at 24VDC.</p>	<p>30VDC</p> <p>Ambient Temperature</p> 

IC200MDD846

**Mixed Module, Output Relay 2.0A per Pt Isolated 8 Points /
Input 120VAC Grouped 8 Points**

Discrete input/output module IC200MDD846 provides 8 discrete inputs and 8 relay outputs. Inputs are positive logic or sourcing-type inputs; they receive current from devices and return the current on the common. Outputs are individually-isolated relays which can drive a maximum of 2A per output. These are Form A relay outputs where the contact is closed when the host CPU is active and the corresponding output logic bit is “1”.

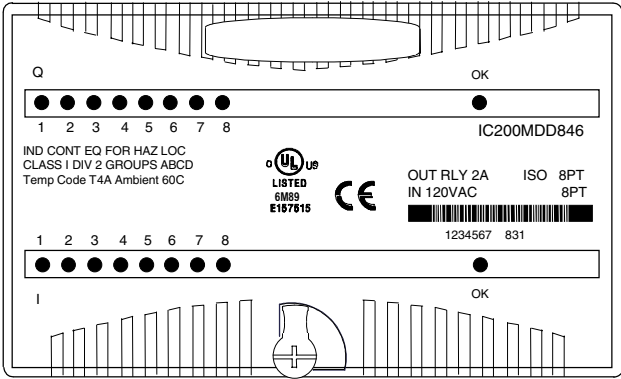

Power for module operation comes from the backplane. Output loads must be powered by an external source.

Intelligent processing for the module is performed by the CPU or NIU. The module provides 8 bits of discrete input data and receives 8 bits of discrete output data.

LED Indicators

Individual green LEDs indicate the On/Off states of the output points and input points. Operation of the output LEDs is logic driven and independent of the load conditions.

The green OK LEDs are on when backplane power is present to the module.

IC200MDD846
Mixed Module, Output Relay 2.0A per Pt Isolated 8 Points /
Input 120VAC Grouped 8 Points

Module Specifications

Module Characteristics	
Points	8 Positive AC Inputs, one group. 8 Individually-isolated Form A Relay Outputs.
Module ID	88048040
Isolation: User input/output to logic (optical) and frame ground Group to group Point to point	250VAC continuous; 1500VAC for 1 minute 250VAC continuous; 1500VAC for 1 minute Outputs: 250VAC continuous; 1500VAC for 1 minute Inputs: none
LED indicators	One LED per point shows individual point on/off state OK LED indicates backplane power is present
Backplane current consumption	5V output: 300mA maximum See graph
Thermal derating	None
Input Characteristics	
Input voltage	0 to 132VAC (47 to 63Hz), 120VAC nominal
On state voltage	70 to 132VAC
Off state voltage	0 to 20VAC
On state current Off state current	5mA minimum 2.5mA maximum
On response time Off response time	1 cycle maximum 2 cycles maximum
Input impedance	8.6kOhms (reactive) at 60Hz, typical 10.32kOhms (reactive) at 50Hz, typical
Output Characteristics	
Output voltage	0 to 125VDC, 5/24/125VDC nominal 0 to 265VAC (47 to 63Hz), 120/240VAC nominal
Output voltage drop	0.3V maximum
Load current	10mA per point minimum 2.0 Amps for 5 to 265VAC maximum (resistive) 2.0 Amps for 5 to 30 VDC maximum (resistive) 0.2 Amp for 31 to 125 VDC maximum (resistive)
Output leakage current	Not applicable (open contact)
On response time Off response time	10ms maximum 10ms maximum
Protection	No internal fuses or snubbers.
Switching frequency	20 cycles per minute (inductive load)
Relay type	Fixed coil, moving armature
Contact type	Silver alloy
Contact life	See appendix B

IC200MDD846
Mixed Module, Output Relay 2.0A per Pt Isolated 8 Points /
Input 120VAC Grouped 8 Points

Field Wiring

Terminal	Connection	Terminal	Connection
A1	Output 1-1	B1	Input 1
A2	Output 1-2	B2	Input 2
A3	Output 2-1	B3	Input 3
A4	Output 2-2	B4	Input 4
A5	Output 3-1	B5	Input 5
A6	Output 3-2	B6	Input 6
A7	Output 4-1	B7	Input 7
A8	Output 4-2	B8	Input 8
A9	Output 5-1	B9	No connection
A10	Output 5-2	B10	No connection
A11	Output 6-1	B11	No connection
A12	Output 6-2	B12	No connection
A13	Output 7-1	B13	No connection
A14	Output 7-2	B14	No connection
A15	Output 8-1	B15	No connection
A16	Output 8-2	B16	No connection
A17	No connection	B17	Inputs 1-8 Common (Return)
A18	No connection	B18	No connection

When wiring outputs to inductive loads, use of external suppression circuits is recommended. See chapter 2, "Installing Wiring for I/O Devices-Wiring to Inductive Loads" for more information.

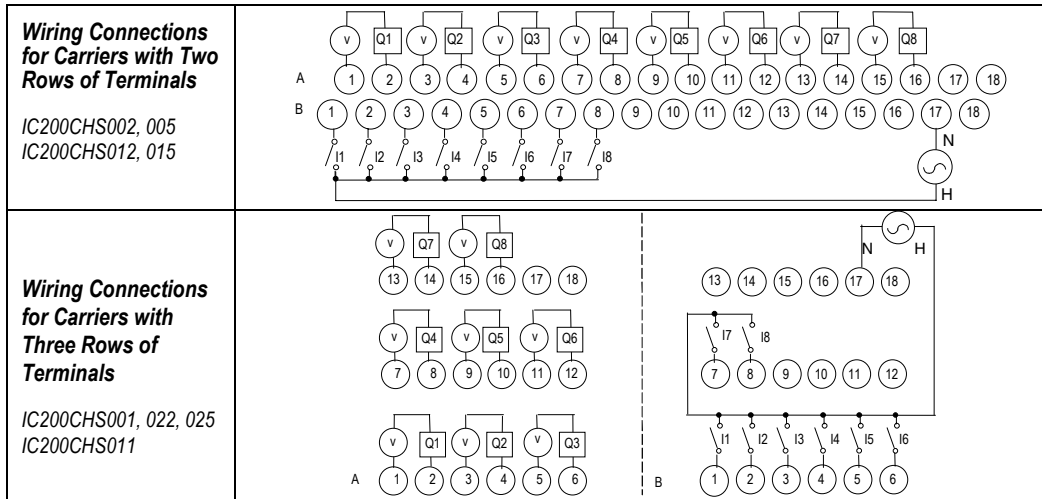

IC200MDD846
Mixed Module, Output Relay 2.0A per Pt Isolated 8 Points /
Input 120VAC Grouped 8 Points

Backplane Power Drain per Point

The module's backplane 5 volt power requirement increases as the number of output points that are simultaneously on increases. The chart below shows the relationship between the number of points on and the maximum current required.

$$\text{mA} = 76 + (28 \times \text{number of output points on})$$

Maximum Current Drawn from Backplane (mA)

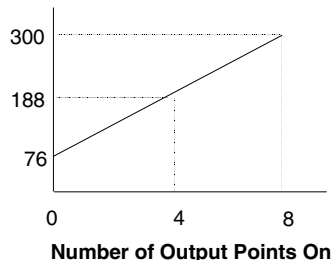

IC200MDD847
Mixed Module, Output Relay 2.0A per Pt Isolated 8 Points /
Input 240VAC Grouped 8 Points

Discrete input/output module IC200MDD847 provides 8 discrete inputs and 8 relay outputs. Inputs are positive logic or sourcing-type inputs; they receive current from devices and return the current on the common. Outputs are individually-isolated relays which can drive a maximum of 2A per output. These are Form A relay outputs where the contact is closed when the host CPU is active and the corresponding output logic bit is “1”.

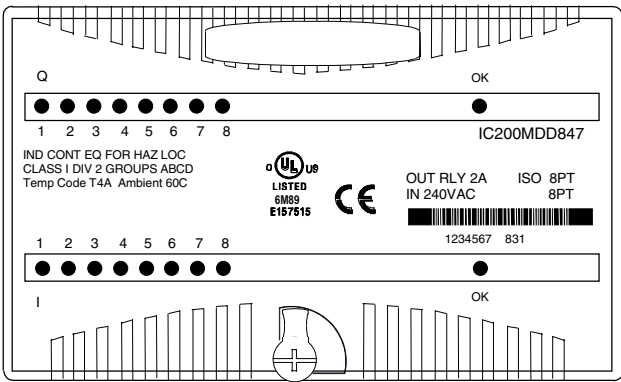

Power for module operation comes from the backplane. Output loads must be powered by an external source.

Intelligent processing for the module is performed by the CPU or NIU. The module provides 8 bits of discrete input data and receives 8 bits of discrete output data.

LED Indicators

Individual green LEDs indicate the On/Off states of the output points and input points. Operation of the output LEDs is logic driven and independent of the load conditions.

The green OK LEDs are on when backplane power is present to the module.

IC200MDD847
Mixed Module, Output Relay 2.0A per Pt Isolated 8 Points /
Input 240VAC Grouped 8 Points

Module Specifications

Module Characteristics	
Points	8 Positive AC Inputs, one group. 8 Individually-isolated Form A Relay Outputs.
Module ID	88048040
Isolation: User input/output to logic (optical) and frame ground Group to group Point to point	250VAC continuous; 1500VAC for 1 minute 250VAC continuous; 1500VAC for 1 minute Outputs: 250VAC continuous; 1500VAC for 1 minute Inputs: none
LED indicators	One LED per point shows individual point on/off state OK LED indicates backplane power is present
Backplane current consumption	5V output: 300mA maximum See graph
Thermal derating	None
Input Characteristics	
Input voltage	0 to 264VAC (47 to 63Hz), 240VAC nominal
On state voltage	155 to 264VAC
Off state voltage	0 to 40VAC
On state current Off state current	4mA minimum 1.5mA maximum
On response time Off response time	1 cycle maximum 2 cycles maximum
Input impedance	38.5kOhms (reactive) at 60Hz, typical 46.3kOhms (reactive) at 50Hz, typical
Output Characteristics	
Output voltage	0 to 125VDC, 5/24/125VDC nominal 0 to 265VAC (47 to 63Hz), 120/240VAC nominal
Output voltage drop	0.3V maximum
Load current	10mA per point minimum 2.0 Amps for 5 to 265VAC maximum (resistive) 2.0 Amps for 5 to 30 VDC maximum (resistive) 0.2 Amp for 31 to 125 VDC maximum (resistive)
Output leakage current	Not applicable (open contact)
On response time Off response time	10ms maximum 10ms maximum
Protection	No internal fuses or snubbers.
Switching frequency	20 cycles per minute (inductive load)
Relay type	Fixed coil, moving armature
Contact type	Silver alloy
Contact life	See appendix B

IC200MDD847
Mixed Module, Output Relay 2.0A per Pt Isolated 8 Points /
Input 240VAC Grouped 8 Points

Field Wiring

Terminal	Connection	Terminal	Connection
A1	Output 1-1	B1	Input 1
A2	Output 1-2	B2	Input 2
A3	Output 2-1	B3	Input 3
A4	Output 2-2	B4	Input 4
A5	Output 3-1	B5	Input 5
A6	Output 3-2	B6	Input 6
A7	Output 4-1	B7	Input 7
A8	Output 4-2	B8	Input 8
A9	Output 5-1	B9	No connection
A10	Output 5-2	B10	No connection
A11	Output 6-1	B11	No connection
A12	Output 6-2	B12	No connection
A13	Output 7-1	B13	No connection
A14	Output 7-2	B14	No connection
A15	Output 8-1	B15	No connection
A16	Output 8-2	B16	No connection
A17	No connection	B17	Inputs 1-8 Common (Return)
A18	No connection	B18	No connection

Outputs are individually isolated. When wiring outputs to inductive loads, use of external suppression circuits is recommended. See chapter 2, "Installing Wiring for I/O Devices- Wiring to Inductive Loads" for more information.

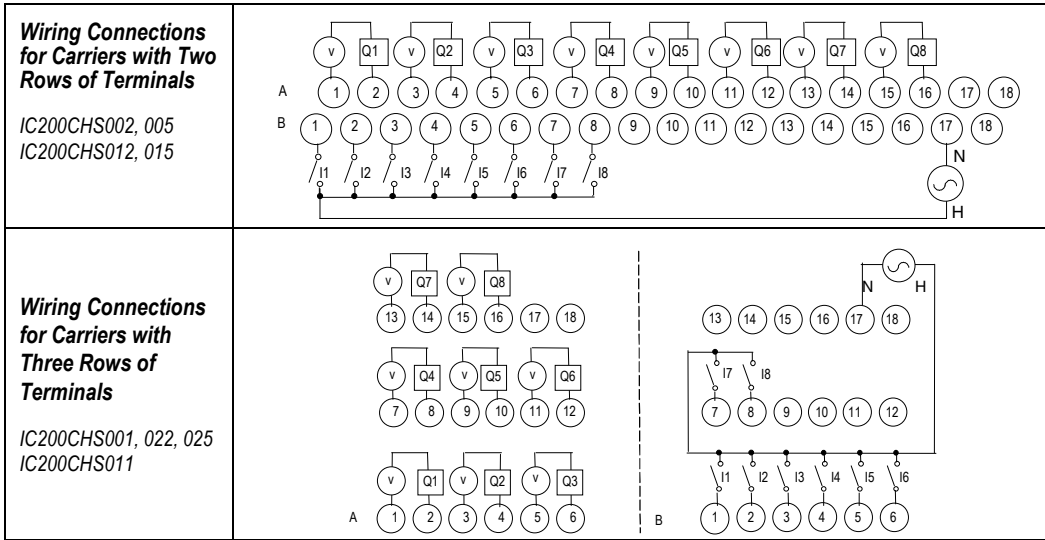

IC200MDD847
Mixed Module, Output Relay 2.0A per Pt Isolated 8 Points /
Input 240VAC Grouped 8 Points

Backplane Power Drain per Point

The module's backplane 5 volt power requirement increases as the number of output points that are simultaneously on increases. The chart below shows the relationship between the number of points on and the maximum current required.

$$\text{mA} = 76 + (28 \times \text{number of output points on})$$

Maximum Current Drawn from Backplane (mA)

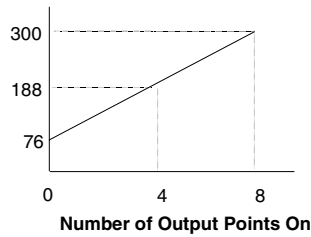

IC200MDD848

**Mixed Module, Output 120VAC 0.5A per Pt Isolated 8 Points /
Input 120VAC Grouped 8 Points**

Discrete input/output module IC200MDD848 provides 8 discrete inputs and 8 discrete outputs. Inputs are positive logic or sourcing-type inputs; they receive current from devices and return the current on the common. Outputs are individually-isolated.

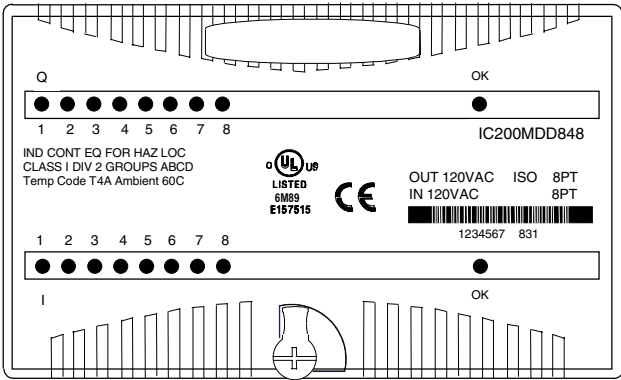

Power for module operation comes from the backplane. An external 120 VAC power supply must be provided for the switches that power the loads.

Intelligent processing for the module is performed by the CPU or NIU. The module provides 8 bits of discrete input data and receives 8 bits of discrete output data.

LED Indicators

Individual green logic-side LEDs indicate the On/Off status of each input/output point. Operation of the Output LEDs are logic-driven and independent of the load conditions.

The green OK LED is ON when backplane power is present to the module.

IC200MDD848
Mixed Module, Output 120VAC 0.5A per Pt Isolated 8 Points /
Input 120VAC Grouped 8 Points

Module Specifications

Module Characteristics	
Points	8 Positive AC Inputs, one group. 8 Individually-isolated Outputs.
Module ID	88048840
Isolation: User input/output to logic (optical) and frame ground Group to group Point to point	250VAC continuous; 1500VAC for 1 minute 250VAC continuous; 1500VAC for 1 minute Outputs: 250VAC continuous; 1500VAC for 1 minute Inputs: none
LED indicators	One LED per point shows individual point on/off state OK LED indicates backplane power is present
Backplane current consumption	5V output: 125mA maximum
Thermal derating	See diagram
Input Characteristics	
Input voltage	0 to 132VAC (47 to 63Hz), 120VAC nominal
On state voltage	70 to 132VAC
Off state voltage	0 to 20VAC
On state current	5mA minimum
Off state current	2.5mA maximum
On response time	1 cycle maximum
Off response time	2 cycles maximum
Input impedance	8.6kOhms (reactive) at 60Hz, typical 10.32kOhms (reactive) at 50Hz, typical
Output Characteristics	
Output voltage	85 to 132 VAC (47 to 63Hz), 120VAC nominal
Output voltage drop	2.0V maximum
Load current	10mA minimum per point 0.5A maximum per point 5.0A for one cycle (20ms) maximum inrush
Output leakage current	Less than 2mA at 132VAC
On response time	Less than ½ cycle, maximum
Off response time	Less than ½ cycle, maximum
Protection	Snubber and MOVs (each output)
Diagnostics	None

IC200MDD848
Mixed Module, Output 120VAC 0.5A per Pt Isolated 8 Points /
Input 120VAC Grouped 8 Points

Field Wiring

Terminal	Connection	Terminal	Connection
A1	Output 1-1	B1	Input 1
A2	Output 1-2	B2	Input 2
A3	Output 2-1	B3	Input 3
A4	Output 2-2	B4	Input 4
A5	Output 3-1	B5	Input 5
A6	Output 3-2	B6	Input 6
A7	Output 4-1	B7	Input 7
A8	Output 4-2	B8	Input 8
A9	Output 5-1	B9	No connection
A10	Output 5-2	B10	No connection
A11	Output 6-1	B11	No connection
A12	Output 6-2	B12	No connection
A13	Output 7-1	B13	No connection
A14	Output 7-2	B14	No connection
A15	Output 8-1	B15	No connection
A16	Output 8-2	B16	No connection
A17	No connection	B17	Inputs 1-8 Common (Return)
A18	No connection	B18	No connection

Outputs are individually isolated. When wiring outputs to inductive loads, use of external suppression circuits is recommended. See chapter 2, "Installing Wiring for I/O Devices- Wiring to Inductive Loads" for more information.

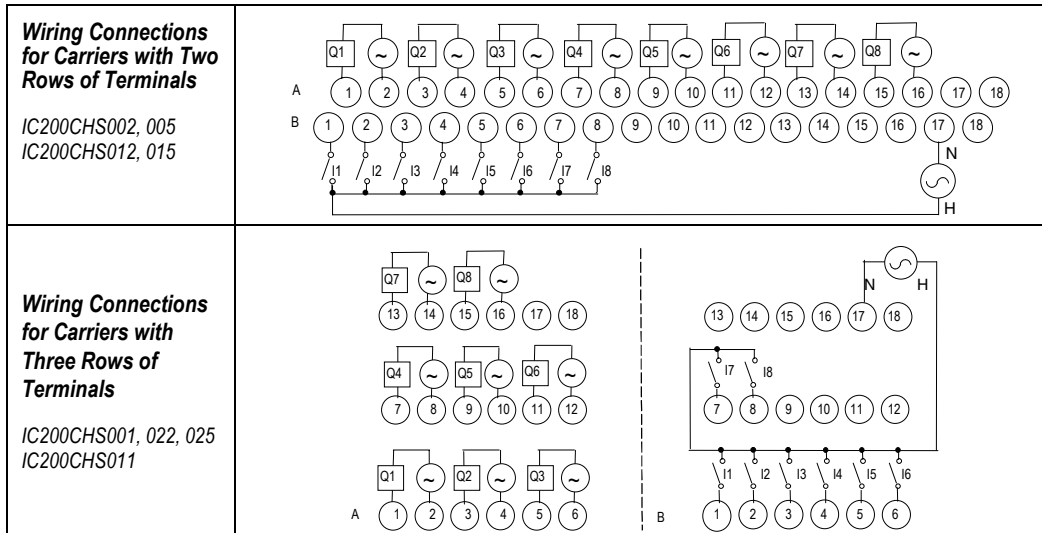

IC200MDD848
Mixed Module, Output 120VAC 0.5A per Pt Isolated 8 Points /
Input 120VAC Grouped 8 Points

Thermal Derating

The number of points that can be on at the same time depends on the ambient temperature, the external voltage, and the orientation of the module and DIN rail. The charts that follow show thermal deratings for this module at 120VAC and 132VAC. The shaded bands represent temperature ranges that represent allowable combinations of inputs points for the indicated number of outputs points. All combinations of points are permissible at lower temperatures. The narrow white line within each range shows maximum temperature when the number of output points equals the number of input points that are on at the same time.

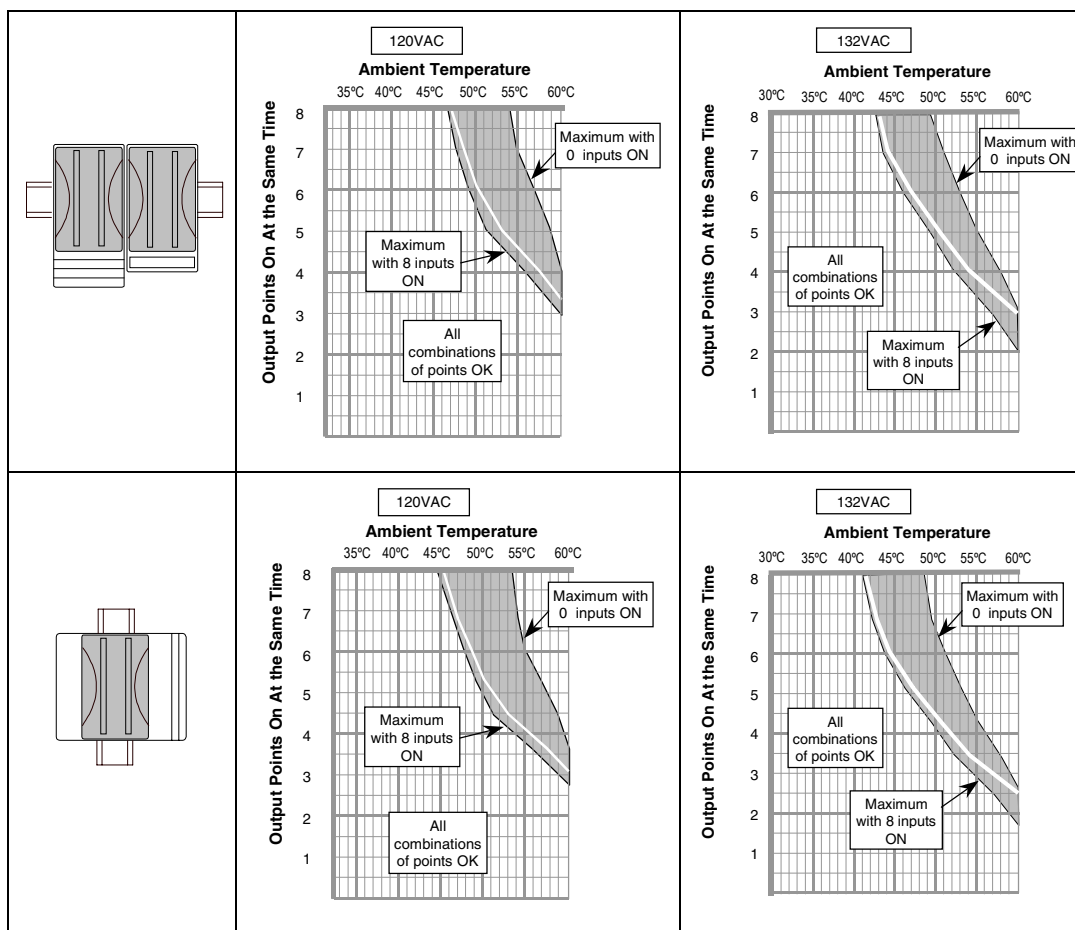

IC200MDD848

**Mixed Module, Output 120VAC 0.5A per Pt Isolated 8 Points /
Input 120VAC Grouped 8 Points**

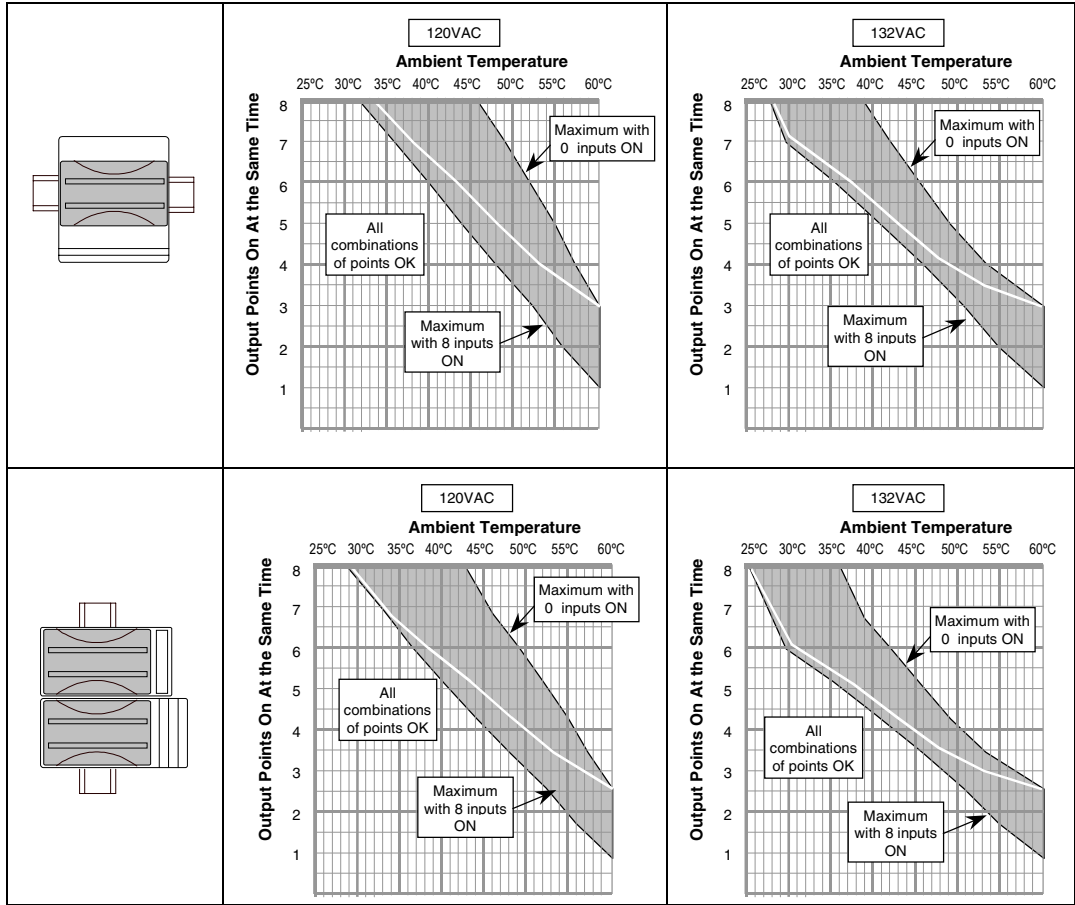

IC200MDD849
Mixed Module Output Relay 2.0A per Pt Isolated 8 Points /
Input 120VAC Isolated 8 Points

Discrete input/output module IC200MDD849 provides 8 isolated discrete inputs and 8 relay outputs. Inputs are positive logic or sourcing-type inputs; they receive current from AC input devices and return the current on the common. Each input has its own return. Outputs are individually-isolated relays which can drive a maximum of 2A per output. These are Form A relay outputs where the contact is closed when the host CPU is active and the corresponding output logic bit is “1”.

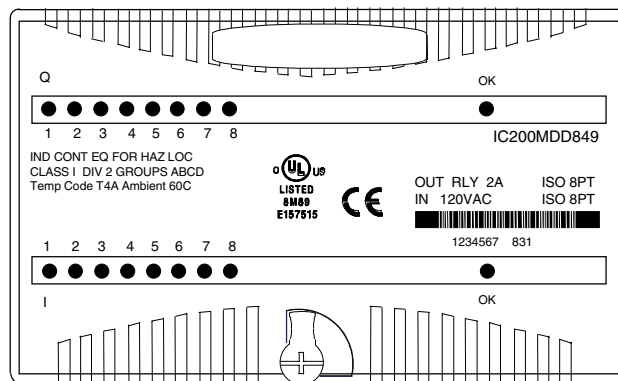

Power for module operation comes from the backplane. Output loads must be powered by an external source.

Intelligent processing for the module is performed by the CPU or NIU. The module provides 8 bits of discrete input data and receives 8 bits of discrete output data.

LED Indicators

Individual green LEDs indicate the On/Off states of the output points and input points. Operation of the output LEDs is logic driven and independent of the load conditions.

The green OK LEDs are on when backplane power is present to the module.

IC200MDD849
Mixed Module Output Relay 2.0A per Pt Isolated 8 Points /
Input 120VAC Isolated 8 Points

Module Specifications

Module Characteristics	
Points	8 Individually-isolated Form A Relay Outputs 8 Isolated AC Inputs
Module ID	88048040
Isolation: User input/output to logic (optical) and frame ground Group to group Point to point	250VAC continuous; 1500VAC for 1 minute 250VAC continuous; 1500VAC for 1 minute Outputs: 250VAC continuous; 1500VAC for 1 minute Inputs: 250VAC continuous; 1500VAC for 1 minute
LED indicators	One LED per point shows individual point on/off state OK LED indicates backplane power is present
Backplane current consumption	5V output: 295mA maximum See graph
Thermal derating	None
Input Characteristics	
Input voltage	0 to 132VAC (47 to 63Hz), 120VAC nominal
On state voltage	70 to 132VAC
Off state voltage	0 to 20VAC
On state current	5mA minimum
Off state current	2.5mA maximum
On response time	1 cycle maximum
Off response time	2 cycles maximum
Input impedance	8.6kOhms (reactive) at 60Hz, typical 10.32kOhms (reactive) at 50Hz, typical
Output Characteristics	
Output voltage	0 to 125VDC, 5/24/125VDC nominal 0 to 265VAC (47 to 63Hz), 120/240VAC nominal
Output voltage drop	0.3V maximum
Load current	10mA per point minimum 2.0 Amps for 5 to 265VAC maximum (resistive) 2.0 Amps for 5 to 30 VDC maximum (resistive) 0.2 Amp for 31 to 125 VDC maximum (resistive)
Output leakage current	Not applicable (open contact)
On response time	10ms maximum
Off response time	10ms maximum
Protection	No internal fuses or snubbers.
Switching frequency	20 cycles per minute (inductive load)
Relay type	Fixed coil, moving armature
Contact type	Silver alloy
Contact life	See appendix B

IC200MDD849
Mixed Module Output Relay 2.0A per Pt Isolated 8 Points /
Input 120VAC Isolated 8 Points

Field Wiring

Terminal	Connection	Terminal	Connection
A1	Output 1-1	B1	Input 1
A2	Output 1-2	B2	Input 1 Return
A3	Output 2-1	B3	Input 2
A4	Output 2-2	B4	Input 2 Return
A5	Output 3-1	B5	Input 3
A6	Output 3-2	B6	Input 3 Return
A7	Output 4-1	B7	Input 4
A8	Output 4-2	B8	Input 4 Return
A9	Output 5-1	B9	Input 5
A10	Output 5-2	B10	Input 5 Return
A11	Output 6-1	B11	Input 6
A12	Output 6-2	B12	Input 6 Return
A13	Output 7-1	B13	Input 7
A14	Output 7-2	B14	Input 7 Return
A15	Output 8-1	B15	Input 8
A16	Output 8-2	B16	Input 8 Return
A17	No connection	B17	No connection
A18	No connection	B18	No connection

Outputs are individually isolated. This module should be used with a compact terminal-style carrier (IC200CHS022 or 025) or with a terminal-style carrier. When wiring outputs to inductive loads, use of external suppression circuits is recommended. See chapter 2, "Installing Wiring for I/O Devices-Wiring to Inductive Loads" for more information.

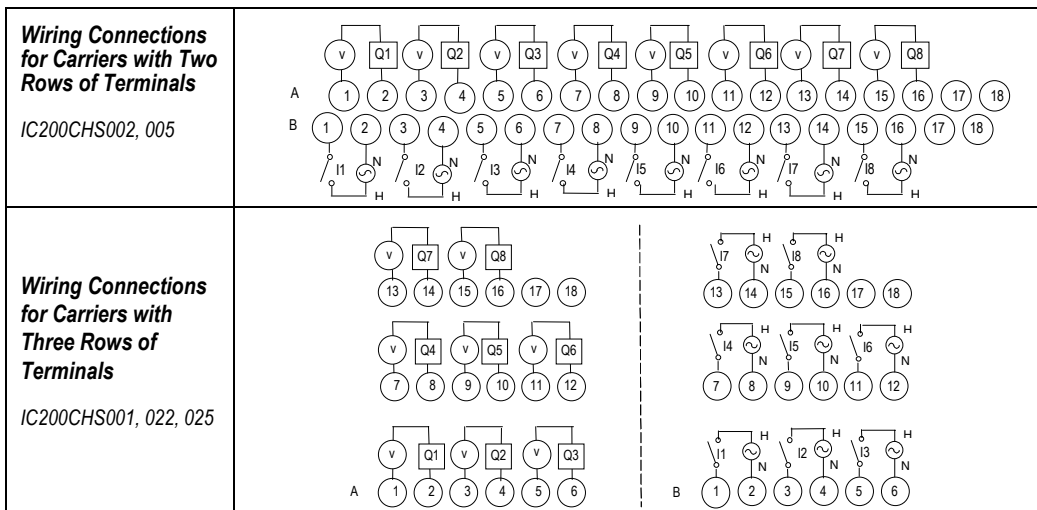

IC200MDD849
Mixed Module Output Relay 2.0A per Pt Isolated 8 Points /
Input 120VAC Isolated 8 Points

Backplane Power Drain per Point

The module's backplane 5 volt power requirement increases as the number of output points that are simultaneously on increases. The chart below shows the relationship between the number of points on and the maximum current required.

$$\text{mA} = 76 + (28 \times \text{number of output points on})$$

Maximum Current Drawn from Backplane (mA)

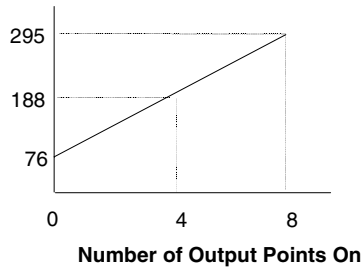

IC200MDD850
Mixed Module, Output Relay 2.0A per Pt Isolated 8 Points /
Input 240VAC Isolated 4 Points

Discrete input/output module IC200MDD850 provides 4 isolated discrete inputs and 8 relay outputs. Inputs are positive logic or sourcing-type inputs; they receive current from AC input devices and return the current on the common. Each input has its own return. Outputs are individually-isolated relays which can drive a maximum of 2A per output. These are Form A relay outputs where the contact is closed when the host CPU is active and the corresponding output logic bit is “1”.

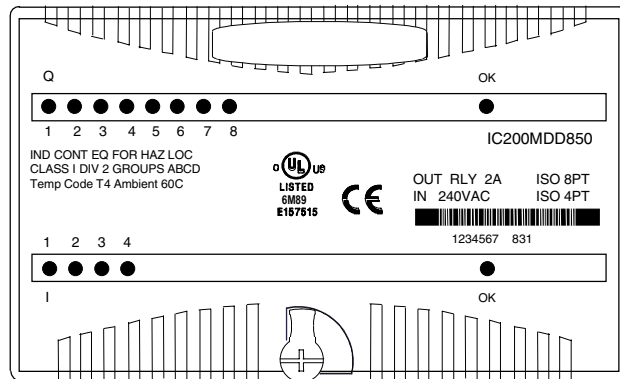

Power for module operation comes from the backplane. Output loads must be powered by an external source.

Intelligent processing for the module is performed by the CPU or NIU. The module provides 4 bits of discrete input data and receives 8 bits of discrete output data.

LED Indicators

Individual green LEDs indicate the On/Off states of the output points and input points. Operation of the output LEDs is logic driven and independent of the load conditions.

The green OK LEDs are on when backplane power is present to the module.

IC200MDD850
**Mixed Module, Output Relay 2.0A per Pt Isolated 8 Points /
 Input 240VAC Isolated 4 Points**

Module Specifications

Module Characteristics	
Points	8 Individually-isolated Form A Relay Outputs 4 Isolated AC Inputs
Module ID	88028040
Isolation: User input/output to logic (optical) and frame ground Group to group Point to point	250VAC continuous; 1500VAC for 1 minute 250VAC continuous; 1500VAC for 1 minute Outputs: 250VAC continuous; 1500VAC for 1 minute Inputs: 250VAC continuous; 1500VAC for 1 minute
LED indicators	One LED per point shows individual point on/off state OK LED indicates backplane power is present
Backplane current consumption	5V output: 275mA maximum See graph
Thermal derating	None
Input Characteristics	
Input voltage	0 to 264VAC (47 to 63Hz), 240VAC nominal
On state voltage	155 to 264VAC
Off state voltage	0 to 40VAC
On state current	4mA minimum
Off state current	1.5mA maximum
On response time	1 cycle maximum
Off response time	2 cycles maximum
Input impedance	38.5kOhms (reactive) at 60Hz, typical 46.3kOhms (reactive) at 50Hz, typical
Output Characteristics	
Output voltage	0 to 125VDC, 5/24/125VDC nominal 0 to 265VAC (47 to 63Hz), 120/240VAC nominal
Output voltage drop	0.3V maximum
Load current	10mA per point minimum 2.0 Amps for 5 to 265VAC maximum (resistive) 2.0 Amps for 5 to 30 VDC maximum (resistive) 0.2 Amp for 31 to 125 VDC maximum (resistive)
Output leakage current	Not applicable (open contact)
On response time	10ms maximum
Off response time	10ms maximum
Protection	No internal fuses or snubbers.
Switching frequency	20 cycles per minute (inductive load)
Relay type	Fixed coil, moving armature
Contact type	Silver alloy
Contact life	See appendix B

IC200MDD850
Mixed Module, Output Relay 2.0A per Pt Isolated 8 Points /
Input 240VAC Isolated 4 Points

Field Wiring

Terminal	Connection	Terminal	Connection
A1	Output 1-1	B1	No connection
A2	Output 1-2	B2	No connection
A3	Output 2-1	B3	Input 1
A4	Output 2-2	B4	Input 1 Return
A5	Output 3-1	B5	No connection
A6	Output 3-2	B6	No connection
A7	Output 4-1	B7	Input 2
A8	Output 4-2	B8	Input 2 Return
A9	Output 5-1	B9	No connection
A10	Output 5-2	B10	No connection
A11	Output 6-1	B11	Input 3
A12	Output 6-2	B12	Input 3 Return
A13	Output 7-1	B13	No connection
A14	Output 7-2	B14	No connection
A15	Output 8-1	B15	Input 4
A16	Output 8-2	B16	Input 4 Return
A17	No connection	B17	No connection
A18	No connection	B18	No connection

Outputs are individually isolated. This module should be used with a compact terminal-style carrier (IC200CHS022 or 025) or with a terminal-style carrier (IC200CHS001, 002, 005 suffix "B" or higher). It cannot be used with a Connector-Style Carrier (IC200CHS003) due to its high isolation requirement. When wiring outputs to inductive loads, use of external suppression circuits is recommended. See chapter 2, "Installing Wiring for I/O Devices-Wiring to Inductive Loads" for more information.

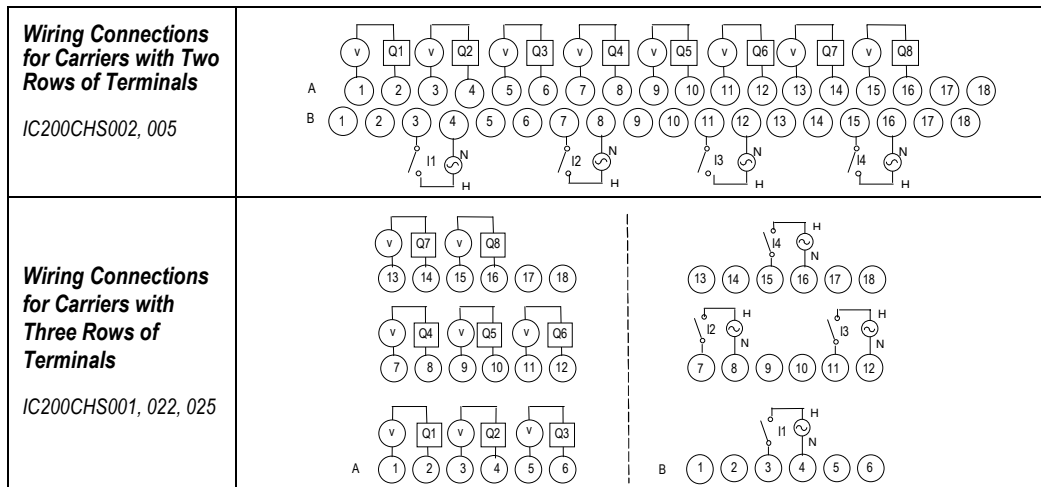

IC200MDD850
Mixed Module, Output Relay 2.0A per Pt Isolated 8 Points /
Input 240VAC Isolated 4 Points

Backplane Power Drain per Point

The module’s backplane 5 volt power requirement increases as the number of output points that are simultaneously on increases. The chart below shows the relationship between the number of points on and the maximum current required.

$$\text{mA} = 56 + (28 \times \text{number of output points on})$$

Maximum Current Drawn from Backplane (mA)

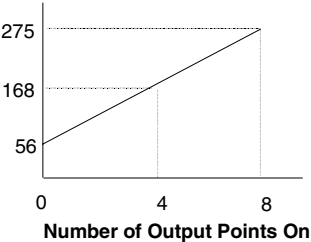

IC200MDD851

**Mixed Module, Output 12/24VDC Positive Logic Grouped
16 Points / Input 5/12VDC Pos/Neg Logic Grouped 16 Points**

Discrete input/output module IC200MDD851 provides two groups of 8 discrete inputs and one group of 16 discrete outputs. Inputs in each group can be either positive logic inputs that receive current from input devices and return the current on the common, or negative logic inputs that receive current from the common and return current to the input device. Input devices are connected between the input terminals and common terminals. For the inputs to be compatible with TTL devices, the negative logic configuration should be used. The outputs are positive or sourcing type outputs. They switch the loads to the positive side of the DC supply and thus supply current to the loads.

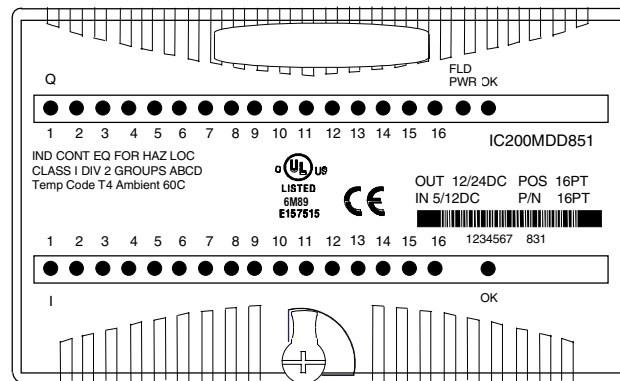

Power for module operation comes from the backplane. Output loads must be powered by an external source.

Intelligent processing for the module is performed by the CPU or NIU. The module provides 4 bits of discrete input data and receives 8 bits of discrete output data.

LED Indicators

Individual green LEDs indicate the On/Off states of the output points and input points. Backplane power must be present for LEDs to provide status of inputs. The output LEDs are dependent on field power, but independent of load conditions.

The green FLD PWR LED is on when field power is applied to the module.

The green OK LEDs are on when backplane power is present to the module.

Configuration Parameters

The module's basic input on/off response time is 0.25 ms. For some applications, it may be preferable to add additional filtering to compensate for conditions such as noise spikes or switch bounce. Input filter times of 0ms, 1.0ms, or 7.0ms are selectable via software configuration, for total response times of 0.25ms, 1.25ms, and 7.25ms respectively. The default is 1.0ms filter time (total response time is 1.25ms).

IC200MDD851
Mixed Module, Output 12/24VDC Positive Logic Grouped
16 Points / Input 5/12VDC Pos/Neg Logic Grouped 16 Points

Module Specifications

Module Characteristics	
Points	One group of 16 Outputs Two groups of 8 Inputs
Module ID	80088080
Isolation: User input/output to logic (optical) and to frame ground Group to group Point to point	250VAC continuous; 1500VAC for 1 minute 250VAC continuous; 1500VAC for 1 minute None
LED indicators	One LED per point shows individual point on/off state FLD PWR LED indicates field power is present OK LED indicates backplane power is present
Backplane current consumption	5V output: 115mA maximum
External power supply	+10.2 to +30VDC, +12/24VDC nominal
Thermal derating	See diagram
Configuration parameters	Input response time
Input Characteristics	
Input voltage	0 to +15VDC, +5/12VDC nominal
User input current	1.8mA typ. @ 5VDC, 4.9mA typ. @ 12VDC
Input impedance	2.4kOhms typ. @12VDC
On state voltage	+4.2 to +15VDC
Off state voltage	0 to +2.6VDC
On state current	1.45mA minimum
Off state current	0 to 0.7mA maximum
On response time	0.25ms maximum
Off response time	
Configurable filter time	0ms, 1.0ms (default), or 7.0mS
Output Characteristics	
Output voltage	+10.2 to +30VDC, +12/24VDC nominal
Output voltage drop	0.3VDC maximum
Load current	0.5 Amp at 30VDC maximum (resistive) 2.0 Amps maximum for 100ms inrush
Output leakage current	0.5mA at 30VDC maximum
On response time	0.2ms maximum
Off response time	1.0ms maximum
Protection	No internal fuses

IC200MDD851
Mixed Module, Output 12/24VDC Positive Logic Grouped
16 Points / Input 5/12VDC Pos/Neg Logic Grouped 16 Points

Field Wiring

Terminal	Connection	Terminal	Connection
A1	Output 1	B1	Input 1
A2	Output 2	B2	Input 2
A3	Output 3	B3	Input 3
A4	Output 4	B4	Input 4
A5	Output 5	B5	Input 5
A6	Output 6	B6	Input 6
A7	Output 7	B7	Input 7
A8	Output 8	B8	Input 8
A9	Output 9	B9	Input 9
A10	Output 10	B10	Input 10
A11	Output 11	B11	Input 11
A12	Output 12	B12	Input 12
A13	Output 13	B13	Input 13
A14	Output 14	B14	Input 14
A15	Output 15	B15	Input 15
A16	Output 16	B16	Input 16
A17	DC -	B17	Inputs 1-8 Common
A18	DC +	B18	Inputs 9-16 Common

The 16 inputs form two groups of 8. Each group has a common connection. When wiring outputs to inductive loads, use of external suppression circuits is recommended. See chapter 2, "Installing Wiring for I/O Devices-Wiring to Inductive Loads" for more information.

IC200MDD851
Mixed Module, Output 12/24VDC Positive Logic Grouped
16 Points / Input 5/12VDC Pos/Neg Logic Grouped 16 Points

Each group may be wired for positive or negative logic inputs. The 16 outputs form one group with a DC+ and a DC- terminal.

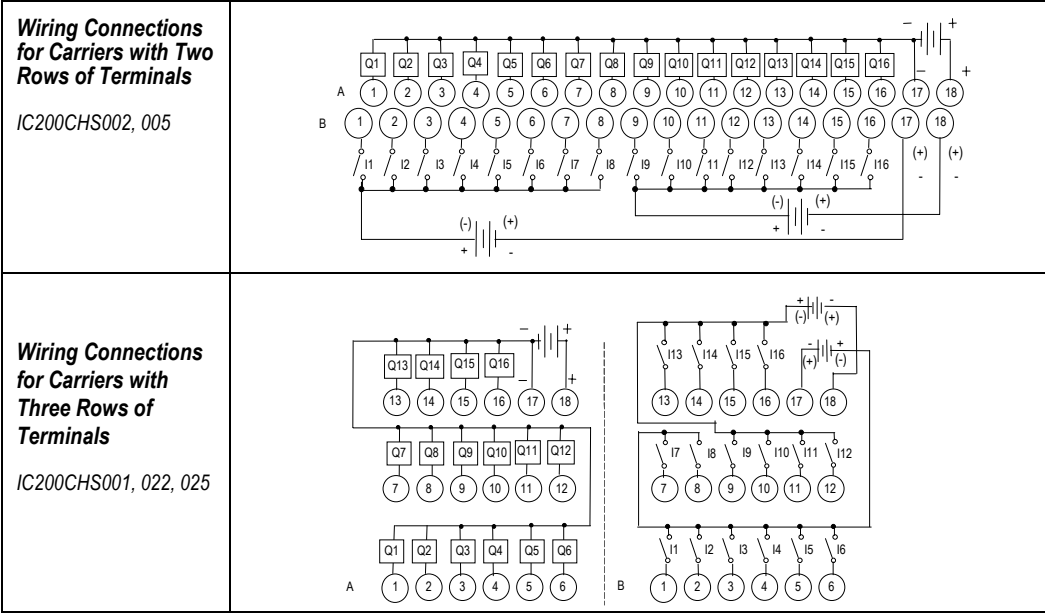

Wiring for TTL Inputs

To be compatible with TTL outputs, the negative logic configuration should be used as shown below.

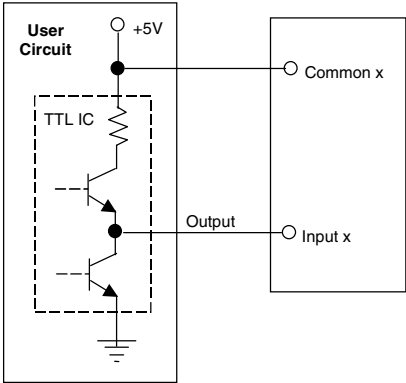

IC200MDD851
Mixed Module, Output 12/24VDC Positive Logic Grouped
16 Points / Input 5/12VDC Pos/Neg Logic Grouped 16 Points

Thermal Derating

The number of points that can be on at the same time depends on the ambient temperature, the external voltage, and the orientation of the module and DIN rail. There is no derating for 12VDC inputs, The charts that follow show thermal deratings for this module at 24VDC. All combinations of points are permissible at lower temperatures.

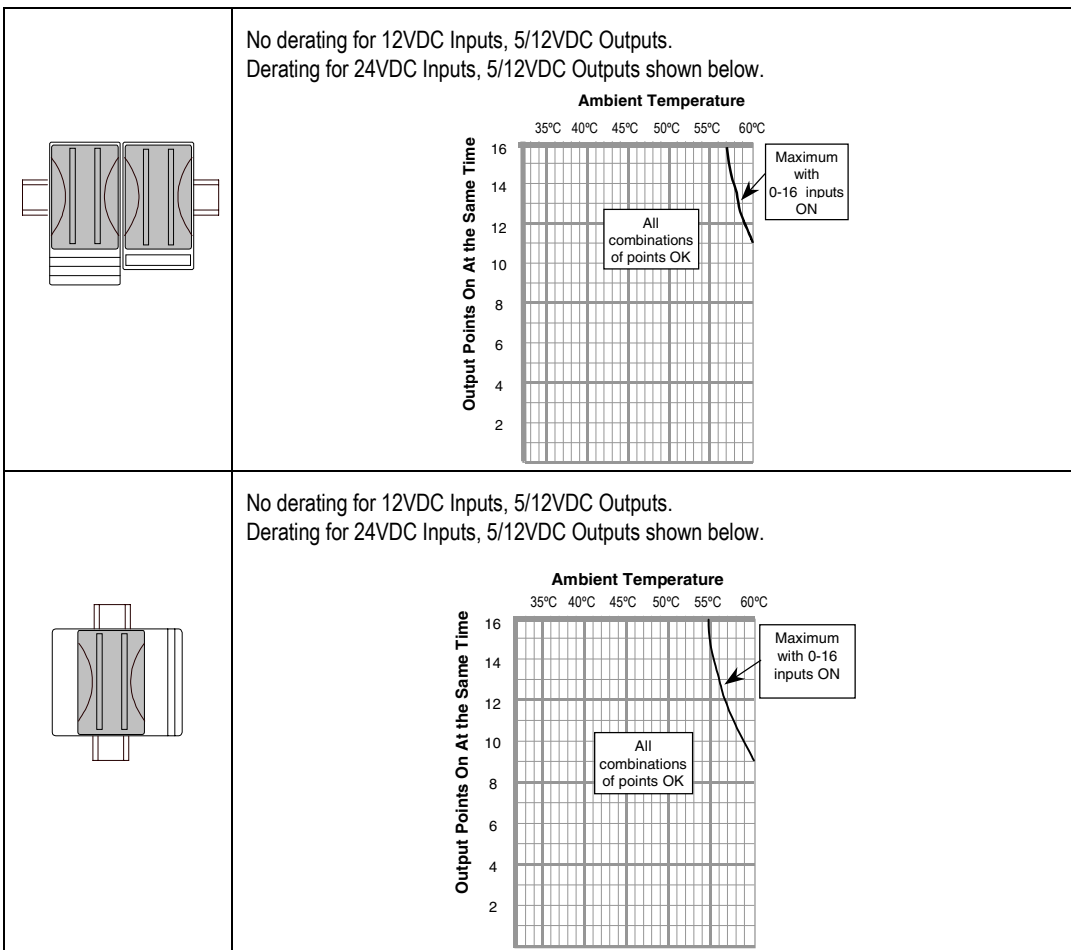

IC200MDD851

**Mixed Module, Output 12/24VDC Positive Logic Grouped
16 Points / Input 5/12VDC Pos/Neg Logic Grouped 16 Points**

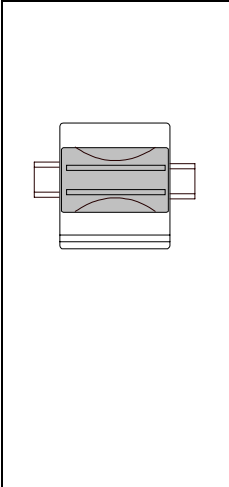

No derating for 12VDC Inputs, 5/12VDC Outputs.
Derating for 24VDC Inputs, 5/12VDC Outputs shown below.

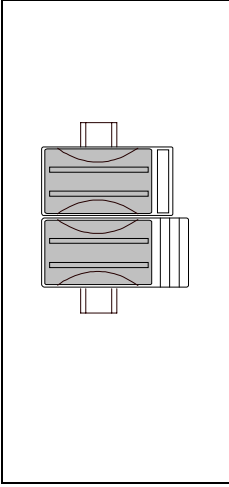
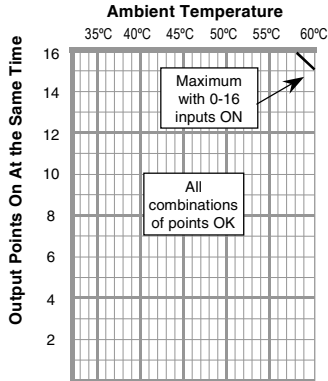

No derating for 12VDC Inputs, 5/12VDC Outputs.
Derating for 24VDC Inputs, 5/12VDC Outputs shown below.

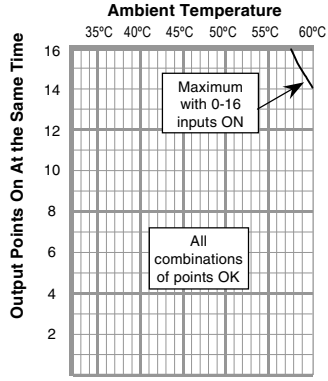

Chapter 10

Analog Input Modules

This chapter describes analog input modules.

- | | |
|---------------|--|
| ▪ IC200ALG230 | Analog Input Module, 12 Bit Voltage/Current 4 Channels |
| ▪ IC200ALG240 | Analog Input Module, 16 Bit Voltage/Current, 1500VAC Isolation, 8 Channels |
| ▪ IC200ALG260 | Analog Input Module, 12 Bit Voltage/Current 8 Channels |
| ▪ IC200ALG261 | Analog Input Module, 15 Bit Differential Voltage 8 Channels |
| ▪ IC200ALG262 | Analog Input Module, 16 Bit Differential Current 8 Channels |
| ▪ IC200ALG263 | Analog Input Module, 15 Bit Voltage 15 Channels |
| ▪ IC200ALG264 | Analog Input Module, 15 Bit Current 15 Channels |

IC200ALG230 **Analog Input Module, 12 Bit Voltage/Current 4 Channels**

Analog input module IC200ALG230 provides an interface to 4 voltage inputs or 4 current inputs. The inputs are single-ended, with all inputs sharing a common return.

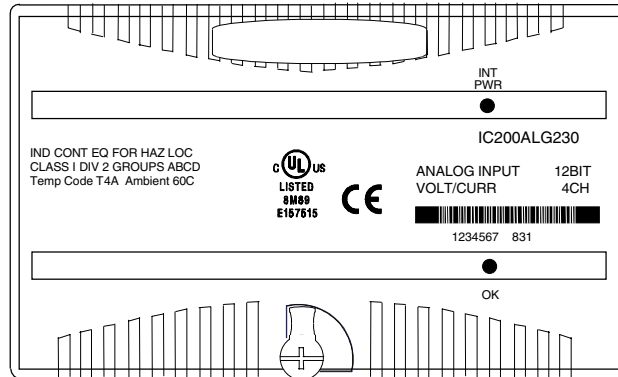

The module receives power from the backplane power supply. No external power source is required for module operation. Power for the user's transceivers must be supplied from an external source.

Intelligent processing for this module is performed by the CPU or NIU. The module provides 4 words of analog input data.

LED Indicators

The green INT PWR LED indicates the presence of internally-generated field power for the analog field-side circuits.

The green OK LED is on when backplane power is present to the module.

Diagnostics

The module reports a Loss of Internal Power fault for field-side circuits.

Configuration Parameters

Two jumpers on the carrier terminals can be used to configure voltage or current mode and unipolar or bipolar operation in voltage mode. One jumper selects either voltage or current operating mode. With this jumper connected, the module accepts current inputs in the 4mA to 20mA range. With no jumper installed the module accepts -10VDC to +10VDC inputs.

In voltage mode, a different jumper on the carrier can be used to select the 0 to 10VDC range.

IC200ALG230

Analog Input Module, 12 Bit Voltage/Current 4 Channels

Module Specifications

Module Characteristics	
Channels	4 single ended, one group
Module ID	FFFF9004
Isolation:	
User input to logic (optical) and to frame ground	250VAC continuous; 1500VAC for 1 minute
Group to group	Not applicable
Channel to channel	None
LED indicators	INT PWR LED indicates internally-generated field power is present OK LED indicates backplane power is present
Backplane current consumption	5V output: 125mA maximum
External power supply	None
Thermal derating	None
Configuration parameters	Range select, Mode select (jumpers on carrier)
Diagnostics	Loss of Internal Power
Input Characteristics: Voltage Mode (default)	
Input voltage:	
Bipolar	+/-10VDC (default)
Unipolar	0 to 10V (configurable)
Input Impedance	126kOhms maximum
Accuracy at:	
25 degrees C*	+/-0.3% typical of full scale, +/-0.5% maximum of full scale
0 to 60 degrees C	+/-1% maximum of full scale
Resolution:	
Bipolar mode:	2.5mV = 8 counts
Unipolar mode:	2.5mV = 8 counts
Filter response	5.0ms
Update rate per module	0.4ms
Common mode voltage	0 V
Channel-to-channel crosstalk rejection	30dB minimum
Input Characteristics: Current Mode	
Input current	4 to 20mA
Input Impedance	200 Ohms maximum
Accuracy at:	
25 degrees C*	+/-0.3% typical of full scale, +/-0.5% maximum of full scale
0 to 60 degrees C	+/-1% maximum of full scale
Resolution	4μA = 8 counts
Filter response	5ms
Update rate per module	0.4ms
Channel-to-channel crosstalk rejection	30dB minimum

* In the presence of severe RF interference, (IEC 1000-4-3, 10V/m), accuracy may be degraded to +/-3%.

IC200ALG230
Analog Input Module, 12 Bit Voltage/Current 4 Channels

Field Wiring

Number	Connection	Number	Connection
A1	V1	B1	No connection
A2	I1	B2	No connection
A3	Return (common)	B3	No connection
A4	V2	B4	No connection
A5	I2	B5	No connection
A6	Return (common)	B6	No connection
A7	V3	B7	No connection
A8	I3	B8	No connection
A9	Return (common)	B9	No connection
A10	V4	B10	No connection
A11	I4	B11	No connection
A12	Return (common)	B12	No connection
A13	JMP1-A	B13	No connection
A14	JMP1-B	B14	No connection
A15	JMP2-A	B15	No connection
A16	JMP2-B	B16	No connection
A17	NC	B17	No connection
A18	NC	B18	No connection

Note: All inputs are single-ended, and share a common return. Either voltage or current devices may be connected per channel (not both).

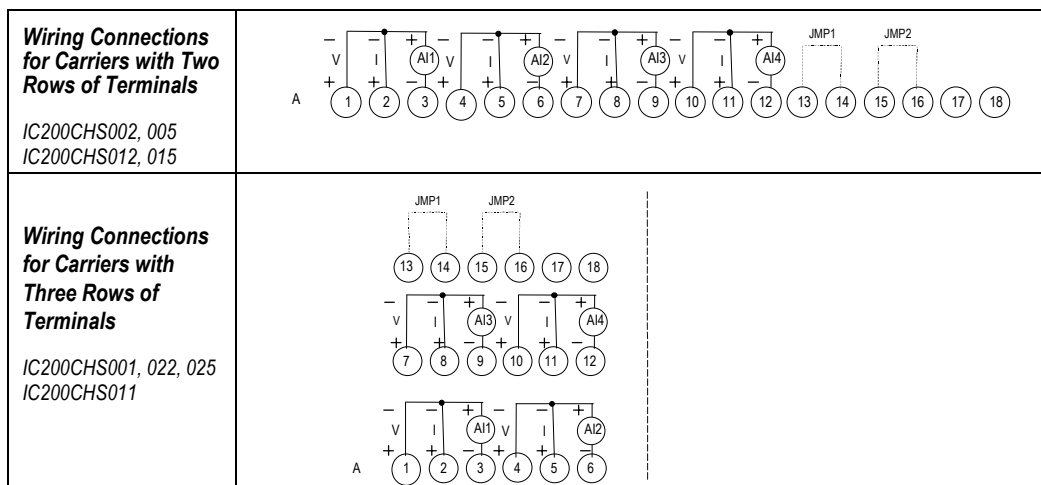

IC200ALG230

Analog Input Module, 12 Bit Voltage/Current 4 Channels

Jumper Selections

Jumpers on JMP 1 and JMP 2 select voltage or current operation and voltage range. In current mode, JMP2 is ignored.

Jumper	Range
None	+/-10V
1	4-20mA
2	0-10V
1 & 2	Not recommended

Wiring Examples

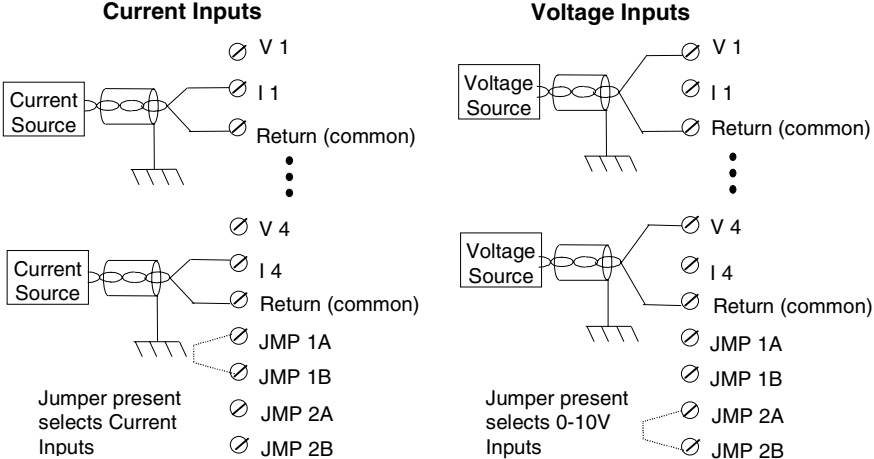

An external source is needed to power input transceivers.

IC200ALG230
Analog Input Module, 12 Bit Voltage/Current 4 Channels**Cable Shield Connections**

If possible, the cable should be grounded at the source device. If that is not possible, the cable shield must be grounded at the source device. If that is not possible, the cable shield must be grounded at the I/O module. This can be done using an Auxiliary I/O Terminal (IC200TBM001, 002, or 005).

If the module is installed on a Terminal-style I/O Carrier (IC200CHS001, 002, or 005), shield connections can be made on an Auxiliary I/O Terminal that is attached to the I/O carrier.

If the module is installed on a Compact Terminal-style I/O Carrier (IC200CHS022, 025), shield connections can be made on an Auxiliary I/O Terminal that is mounted near the I/O carrier. Be sure to ground the Auxiliary I/O Terminal Strip if you plan to use it for this purpose.

If the module is installed on a Connector-style I/O Carrier (IC200CHS003), the cable shield can be connected directly to an Interposing Terminal (IC200CHS011, 012, 015). Be sure to ground the Interposing Terminal. It is recommended to use a shielded interposing cable as well between the Interposing Terminal and the Connector Base. A custom shielded cable can be made using the Connector kit (IC200ACC302). In addition, a custom shield braid can be wrapped around standard Interposing Cables (IC200CBL105, 110, 120, 230). If this approach is used be sure to ground the braid.

IC200ALG230

Analog Input Module, 12 Bit Voltage/Current 4 Channels

Scaling

The graphs below show the relationship between the input voltage or current measured at the field terminals and the data that is output by the module.

Count and Input Current

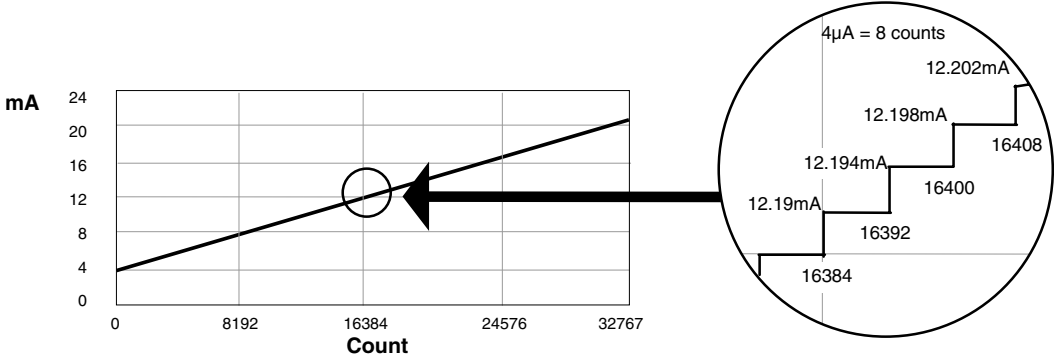

The following equation can be used to calculate counts values:

$$\text{Counts} = (\text{Current in mA} - 4\text{mA}) \times (32768 / 16.38\text{mA})$$

For a change in the reported count value to be seen, input current must be increased by at least 4µA. If the module receives an increase less than 4µA, the previous count value is still reported. For example:

Current	Count
12.190mA	16384
12.192mA	16384
12.194mA	16392

IC200ALG230
Analog Input Module, 12 Bit Voltage/Current 4 Channels

Count and Input Voltage

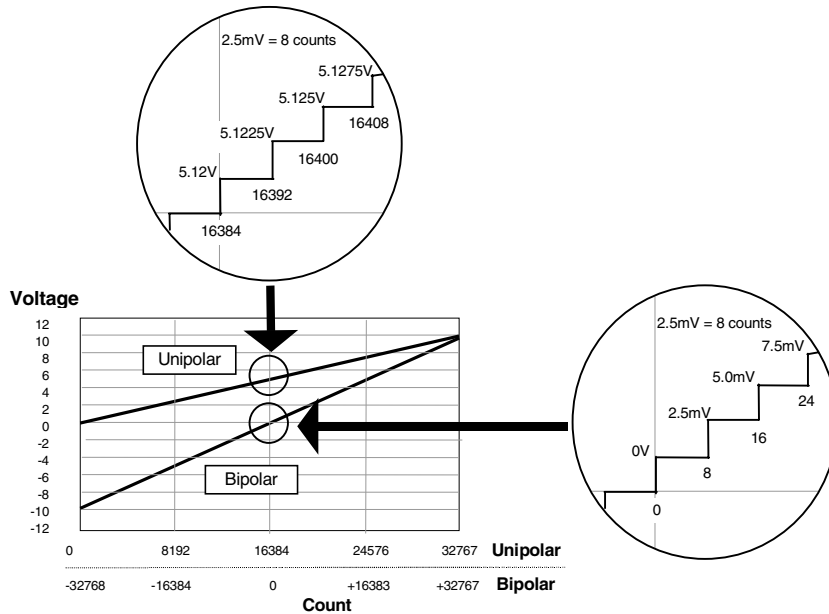

The following equations can be used to calculate counts values:

Bipolar voltage: Counts = (±Voltage In) x (3200)

Unipolar voltage: Counts = (+Voltage In) x (3200)

For a change in the reported count value to be seen, input current must be increased by at least 2.5mV. If the module receives an increase less than 2.5mV, the previous count value is still reported. For example:

Voltage	Count
5.1200V	16384
5.1220V	16384
5.1225V	16392

Input Defaults

The module's analog input (%AI) data can be configured to either hold last state or to go to a configured value if an error causes the inputs to default.

If the module is autoconfigured, the input default is 0.

IC200ALG240

Analog Input Module, 16 Bit Voltage/Current, 1500VAC Isolation, 8 Channels

Analog input module IC200ALG240 provides eight analog inputs. Features include:

- Eight isolated 4-20mA current input channels
- Sixteen-bit converter resolution
- Open wire detection
- High-accuracy factory calibration

The following additional features are software-configurable:

- Per-channel selection of 4-20mA current or +/-10V voltage inputs
- Selectable input filter to reject normal mode AC pickup noise
- Selection of default/hold last state operation
- Per-channel selection of default values
- Per-channel selection of under-range and over-range diagnostics levels
- Per-channel selection of alarm levels
- Per-channel scaling
- Field re-calibration on command from VersaMax PLC CPU

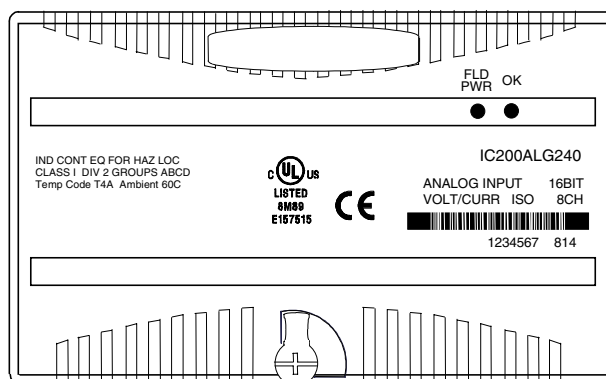

In current mode, a separate power supply may be required for isolated inputs.

The module provides 8 words of analog input data to the system CPU or NIU.

LED Indicators

The green FLD PWR LED indicates the presence of both backplane power and field power for the analog field-side circuits. The absence of either backplane or field power turns off the FLD PWR LED.

The OK LED indicates module status:

- On green indicates normal operation
- Flashing green indicates boot mode or update
- Flashing amber indicates self-diagnostic error
- Off indicates no 3.3V backplane power

IC200ALG240
Analog Input Module, 16 Bit Voltage/Current, 1500VAC Isolation, 8 Channels

Module Specifications

Module Characteristics	
Channels	8 inputs
Module ID	FFFF9802
Isolation: User input to logic (optical) and to frame ground, Group to Group Channel to channel	250VAC continuous; 1500VAC for 1 minute Not applicable 250VAC continuous; 1500VAC for 1 minute
LED indicators	FLD PWR LED indicates the presence of both logic power and user power. OK LED indicates module status.
Backplane current consumption	5V output: 15mA maximum. 3.3V output: 120mA maximum
External power supply: Range Current consumption	+19.5 to +30VDC including ripple 100mA maximum plus load currents
Thermal derating	None
Diagnostics	High/Low Limit, Over/Underrange, Open Wire, Loss of Field Power Supply, Non-volatile memory fault
Input Characteristics	
Input operating range	Current mode: +1 to 20mA Voltage mode: +/-10VDC
Accuracy at 25 degrees C	+/- 0.1% maximum of full scale
Temperature coefficient	Current mode: 45ppm/°C typical, 90 ppm/°C maximum Voltage mode: 30ppm/°C typical, 60 ppm/°C maximum
Analog Resolution (1 LSB)	Current mode: 381 nA nominal Voltage mode: 381 μ V nominal
Channel data Update rate per module	Approximately 20 mS max. @ 50 Hz filter frequency Approximately 16.7 mS max. @ 60 Hz filter frequency
Channel-to-channel crosstalk rejection	70dB minimum
Input default	0 (default) Hold Last State (configurable)
Field input DC resistance	Current mode: 150 Ohms Voltage mode: 760 KOhms
Field input filter	Type: Digital w/programmable notches at 50 or 60 Hz 3 dB Corner Frequency: 10Hz \pm 25%
Normal mode (power line frequency) rejection	35 dB minimum
Field Input Ranges	Current mode: Approximately 0 mA to +25 mA Voltage mode: Approximately -12.5 V to +12.5 V
Maximum field input (without damage)	Current mode: \pm 35 mA continuous Voltage mode: \pm 17.5 V continuous

IC200ALG240

Analog Input Module, 16 Bit Voltage/Current, 1500VAC Isolation, 8 Channels

Field Wiring

Number	Connection	Number	Connection
A1	Shield Termination Point	B1	Shield Termination Point
A2	VIN1-	B2	VIN5-
A3	IIN1-	B3	IIN5-
A4	VINIIN1+	B4	VINIIN5+
A5	Shield Termination Point	B5	Shield Termination Point
A6	VIN2-	B6	VIN6-
A7	IIN2-	B7	IIN6-
A8	VINIIN2+	B8	VINIIN6+
A9	Shield Termination Point	B9	Shield Termination Point
A10	VIN3-	B10	VIN7-
A11	IIN3-	B11	IIN7-
A12	VINIIN3+	B12	VINIIN7+
A13	Shield Termination Point	B13	Shield Termination Point
A14	VIN4-	B14	VIN8-
A15	IIN4-	B15	IIN8-
A16	VINIIN4+	B16	VINIIN8+
A17	DC-	B17	No connection
A18	DC+	B18	No connection

A 24 volt power supply must be connected to A17 and A18 to operate the module. The power wiring does not require shielding. Current inputs are applied with positive current flow into VININn+ and out of IINn-. Both negative terminals IINn- and VINn- of the channel should be connected together for best accuracy on current ranges. Voltage inputs are applied between VININn+ and VINn- with positive to VININn+.

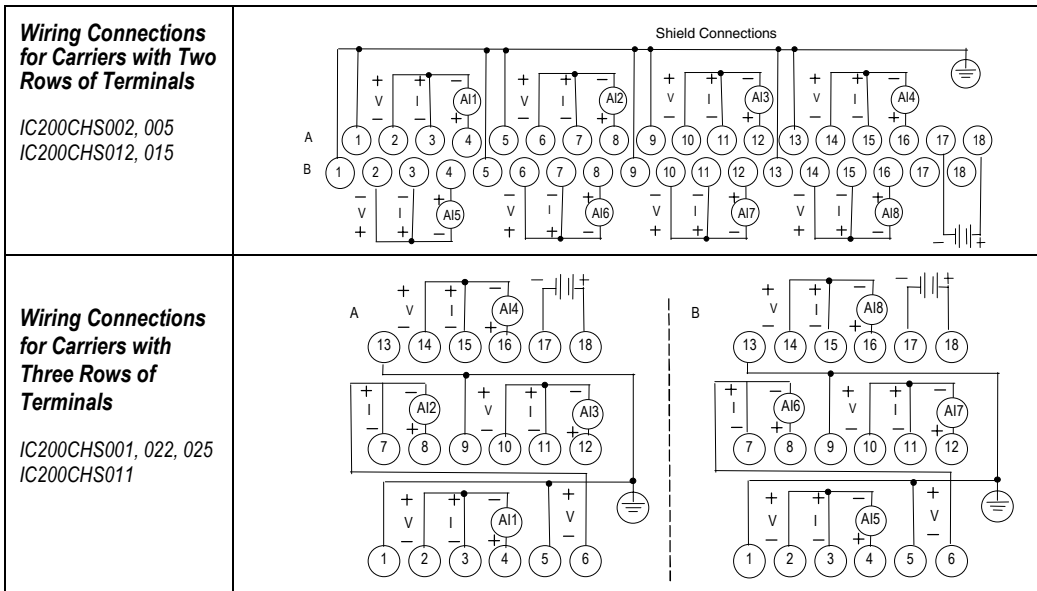

IC200ALG240
Analog Input Module, 16 Bit Voltage/Current, 1500VAC Isolation, 8 Channels**Cable Shield Connections**

If possible, analog input channel connections should be grounded at the source device. If that is not possible, the cable shield must be grounded at the I/O module.

If the module is installed on a Terminal-style I/O Carrier (IC200CHS001, 002, or 005) or a Compact Terminal-style I/O Carrier (IC200CHS022 or 025), the cable shield can be connected directly to the carrier per the Field Wiring Table. An Auxiliary I/O Terminal Strip (IC200TBM001, 002, or 005) can also be added to the Terminal-style I/O Carriers to aid in grounding shields. If the module is installed on a Compact Terminal-style I/O Carrier (IC200CHS022, 025), shield connections can be made on an Auxiliary I/O Terminal that is mounted near the I/O carrier. Be sure to ground the Auxiliary I/O Terminal Strip as well if you plan to use it for this purpose.

If the module is installed on a Connector-style I/O Carrier (IC200CHS003), the cable shield can be connected directly to an Interposing Terminal (IC200CHS011, 012, 015). Be sure to ground the Interposing Terminal. It is recommended to use a shielded interposing cable as well between the Interposing Terminal and the Connector Base. A custom shielded cable can be made using the Connector kit (IC200ACC302). In addition, a custom shield braid can be wrapped around standard Interposing Cables (IC200CBL105, 110, 120, 230). If this approach is used be sure to ground the braid.

Operation

The default parameters of this module can be used in many applications. The module can be software-configured when it is installed in a VersaMax PLC system, or an I/O Station controlled by a Network Interface Unit that is version 2.0 or above. The module is configured at startup. If the module is autoconfigured, it will operate with its default features. After configuration, the module begins receiving signals from the input devices connected to it.

Calibration

The module is calibrated at the factory. For most applications, no further calibration is required. It is possible to perform recalibration in either of the following ways:

- By changing a module's scaling so its scaled data agrees with metered values.
- By sending the module a recalibration message as described in the PLC User's Manual. Note that the module must be power cycled when reverting from field calibration back to factory calibration.

IC200ALG240
Analog Input Module, 16 Bit Voltage/Current, 1500VAC Isolation, 8 Channels

Diagnostics

By default, the module is configured for fault reporting. The module reports faults as soon as they are detected. Once a fault has been reported, the same fault is not reported again until the fault has been cleared. Fault reporting can be disabled via configuration. If disabled, faults are not reported. The module can detect and report the following faults:

Over-Range

The module reports an Over Range fault if an input value is greater than approximately +12.5 volts or 25 mA.

Under-Range

The module reports an Under Range fault if an input value is approximately 0mA on a current channel or -12.5 volts on a voltage channel.

Open Wire

The module reports an Open Wire fault on current inputs if the configuration of the low end of the range is greater than or equal to approximately 2.0 mA, but the input is not detecting current.

Loss of Field Power Supply

The module reports a Loss of Field Power fault if field power is not present (also indicated by the FLD PWR LED). Inputs default as specified by the configuration.

High Limit

The module reports a High Alarm fault if an input value is greater than or equal to the value specified by the “Alarm High” configuration parameter.

Low Limit

The module reports a Low Alarm fault if an input value is less than or equal to the value specified by the “Alarm Low” configuration parameter.

Non-volatile Memory Fault

The module reports this fault only during field recalibration if a non-volatile memory fault is detected.

IC200ALG240
Analog Input Module, 16 Bit Voltage/Current, 1500VAC Isolation, 8 Channels

Configurable Parameters

The default parameters of this module can be used in many applications. The module can be software-configured when it is installed in a VersaMax PLC system, or an I/O Station controlled by a Network Interface Unit that is version 2.0 or above.

Module Parameter	Description	Default	Choices
Analog Input Data Reference	Starting offset for the module's analog input data.		user selectable
Analog Input Data Length	Word length of the module's analog input data.	8	0-8
Line Frequency	Specifies the line filter frequency.	60 Hz	50 Hz, 60 Hz
Report Faults	Enables or disables Fault Reporting for the entire Module.	Enabled	Enabled, Disabled
%AI Default /Hold Last State	Specifies whether the module will go to the specified channel defaults (see below) or hold their last states if power or communications are lost.	Default	Default /Hold
Current /Voltage	Specifies whether the channel will be a voltage or current input. If the Channel type is Current, the range is 4 to 20mA. If Channel type is Voltage, the range is -10 to +10V.	I (Current)	I (Current), V (Voltage)
Channel Active	Specifies if the channel should input data received from the CPU or NIU. If a channel is "inactive" space is still allocated for it.	Active	Inactive (off), Active (on)
Span Low	Actual current (in microAmps) or voltage (in milliVolts) to be scaled from low engineering units value.	4,000 μ A	0 to 25,000 μ A -10,000 to +10,000mV
Span High	Actual current in microAmps or voltage in millivolts to be scaled from the high engineering units value.	20,000 μ A	0 to 25,000 μ A -10,000 to +10,000mV
Engineering Low	The engineering units value that is considered equivalent to the low span (actual) value.	4000	0 to 25,000 μ A -10,000 to +10,000mV
Engineering High	The engineering units value that is considered equivalent to the high span (actual) value.	20000	0 to 25,000 μ A -10,000 to +10,000mV
Alarm Low	The low alarm limit for the channel, in engineering units.	4000	-32768 to +32767
Alarm High	The high alarm limit for the channel, in engineering units.	20000	-32768 to +32767
Default	The value to be input when the module is in a default condition.	0	-32768 to +32767

IC200ALG240

Analog Input Module, 16 Bit Voltage/Current, 1500VAC Isolation, 8 Channels

Configuring Scaling

The module converts electrical signals (either current or voltage, as configured) into digital output values for the CPU or NIU. By default, the module converts this data from 1 millivolt or 1 microamp “internal units” for convenience in scaling and comparing to actual meter measurements.

The module’s default scaling can be changed to tailor the data for a specific application. Typically, engineering units represent millivolts or microamps. But they may also represent physical units such as degrees or centimeters per second. When reconfiguring scaling, it is important to be sure that the chosen Engineering Units values would not result in Overrange or Underrange output levels.

The scaling for each channel can be configured independently. Scaling is configured by selecting corresponding low and high engineering units values and low and high internal values (counts) for two points.

During operation, the module will use the straight line defined by these two pairs of configured scaling values to convert internal values to current or voltage signal levels that represent appropriate engineering units.

Scaling Values for 1mV or 1μA Engineering Units

For many applications, the engineering units are either millivolts or microAmps. These units are easy to scale. Simply use the table below to find scaling values that are appropriate for the channel’s configured range.

Examples	Input Range	Enter this engineering units value		Span Units (microAmps)	
4 mA to 20 mA	4 mA	Low	+4,000	Low	+4,000
	20 mA	High	+20,000	High	+20,000
-10 volts to +10 volts	0 volts	Low	0	Low	+4,000
	+10 volts	High	+10,000	High	+20,000
0 mA to 20 mA	0 mA	Low	0	Low	0
	20 mA	High	+20,000	High	+20,000
-10 volts to +10 volts	-5 volts	Low	-5,000	Low	-5,000
	+10 volts	High	+10,000	High	+10,000

IC200ALG240
Analog Input Module, 16 Bit Voltage/Current, 1500VAC Isolation, 8 Channels

Scaling Example

A channel is configured in the 0 to 10 volts DC range. It measures a velocity input. Electronic sensors and mechanical linkage external to the module have determined that an input level of +1.5 volts DC is equal to -20 feet/second (-6 meters/second), and that +9 volts DC is equal to +180 feet/second (+50 meters/second). Plotting these values on a graph shows that a signal of 5 volts DC corresponds to a speed of 73.3 feet/second.

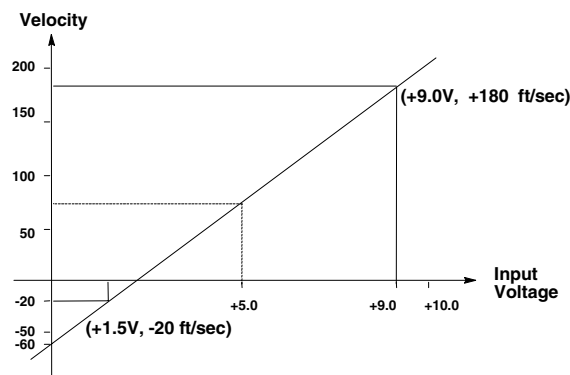

For engineering units of feet per second, the following scaling values are used:

Low engineering units	=	-20	ft/sec
High engineering units	=	+180	ft/sec
Low span units	=	1500	millivolts
High span units	=	9000	millivolts

An input value of 5.0 volts would be scaled to an engineering value of +00073 (ft/sec).

In this example, scaling to hundredths of feet per second would provide better resolution. The following scaling values would be used:

Low engineering units	=	-2000	hundredths ft/sec
High engineering units	=	+1800	hundredths ft/sec
Low span units	=	1500	millivolts
High span units	=	9000	millivolts

An input value of 5.0 volts would be scaled to an engineering value of +7333 (hundredths of ft/sec).

IC200ALG260 **Analog Input Module, 12 Bit Voltage/Current 8 Channels**

Analog input module IC200ALG260 provides an interface to 8 voltage inputs or 8 current inputs. The inputs are single-ended, with all inputs sharing a common return.

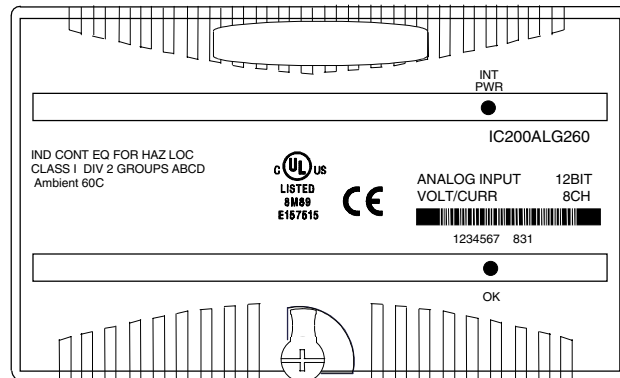

The module receives power from the backplane power supply. No external power source is required for module operation. Power for the user's transceivers must be supplied from an external source.

Intelligent processing for this module is performed by the CPU or NIU. The module provides 8 words of analog input data.

LED Indicators

The green INT PWR LED indicates the presence of internally-generated field power for the analog field-side circuits.

The green OK LED is on when backplane power is present to the module.

Diagnostics

The module reports a Loss of Internal Power fault for field-side circuits.

Configuration Parameters

Two jumpers on the carrier terminals can be used to configure voltage or current mode and unipolar or bipolar operation in voltage mode. One jumper selects either voltage or current operating mode. With this jumper connected, the module accepts current inputs in the 4mA to 20mA range. With no jumper installed the module accepts -10VDC to +10VDC inputs.

In voltage mode, a different jumper on the carrier can be used to select the 0 to 10VDC range.

IC200ALG260
Analog Input Module, 12 Bit Voltage/Current 8 Channels

Module Specifications

Module Characteristics	
Channels	8 single ended, one group
Module ID	FFFF9008
Isolation:	
User input to logic (optical) and to frame ground	250VAC continuous; 1500VAC for 1 minute
Group to group	Not applicable
Channel to channel	None
LED indicators	INT PWR LED indicates internally-generated field power is present OK LED indicates backplane power is present
Backplane current consumption	5V output: 130mA maximum
External power supply	None
Thermal derating	None
Configuration parameters	Range select, Mode select (jumpers on carrier)
Diagnostics	Loss of Internal Power
Input Characteristics: Voltage Mode (default)	
Input voltage:	
Bipolar	+/-10VDC (default)
Unipolar	0 to 10V (configurable)
Input Impedance	126kOhms maximum
Accuracy at:	
25 degrees C*	+/-0.3% typical of full scale, +/-0.5% maximum of full scale
0 to 60 degrees C	+/-1% maximum of full scale
Resolution:	
Bipolar mode:	2.5mV = 8 counts
Unipolar mode:	2.5mV = 8 counts
Filter response	5.0ms
Update rate per module	0.4ms
Common mode voltage	0 V
Channel-to-channel crosstalk rejection	30dB minimum
Input Characteristics: Current Mode	
Input current	4 to 20mA
Input Impedance	200 Ohms maximum
Accuracy at:	
25 degrees C*	+/-0.3% typical of full scale, +/-0.5% maximum of full scale
0 to 60 degrees C	+/-1% maximum of full scale
Resolution	4μA = 8 counts
Filter response	5ms
Update rate per module	0.4ms
Channel-to-channel crosstalk rejection	30dB minimum

* In the presence of severe RF interference, (IEC 1000-4-3, 10V/m), accuracy may be degraded to +/-3%.

IC200ALG260
Analog Input Module, 12 Bit Voltage/Current 8 Channels

Field Wiring

Number	Connection	Number	Connection
A1	V1	B1	V5
A2	I1	B2	I5
A3	Return (common)	B3	Return (common)
A4	V2	B4	V6
A5	I2	B5	I6
A6	Return (common)	B6	Return (common)
A7	V3	B7	V7
A8	I3	B8	I7
A9	Return (common)	B9	Return (common)
A10	V4	B10	V8
A11	I4	B11	I8
A12	Return (common)	B12	Return (common)
A13	JMP1-A	B13	No connection
A14	JMP1-B	B14	No connection
A15	JMP2-A	B15	No connection
A16	JMP2-B	B16	No connection
A17	NC	B17	No connection
A18	NC	B18	No connection

Note: All inputs are single-ended, and share a common return. Either voltage or current devices may be connected per channel (not both).

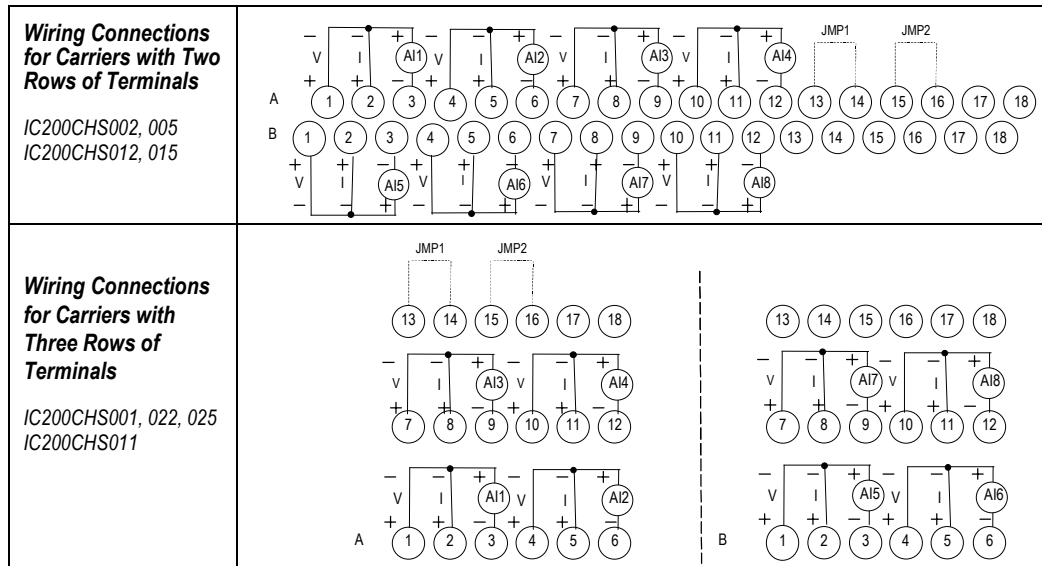

IC200ALG260
Analog Input Module, 12 Bit Voltage/Current 8 Channels

Jumper Selections

Jumpers on JMP 1 and JMP 2 select voltage or current operation and voltage range. In current mode, JMP2 is ignored.

Jumper	Range
None	+/-10V
1	4-20mA
2	0-10V
1 & 2	Not recommended

Wiring Examples

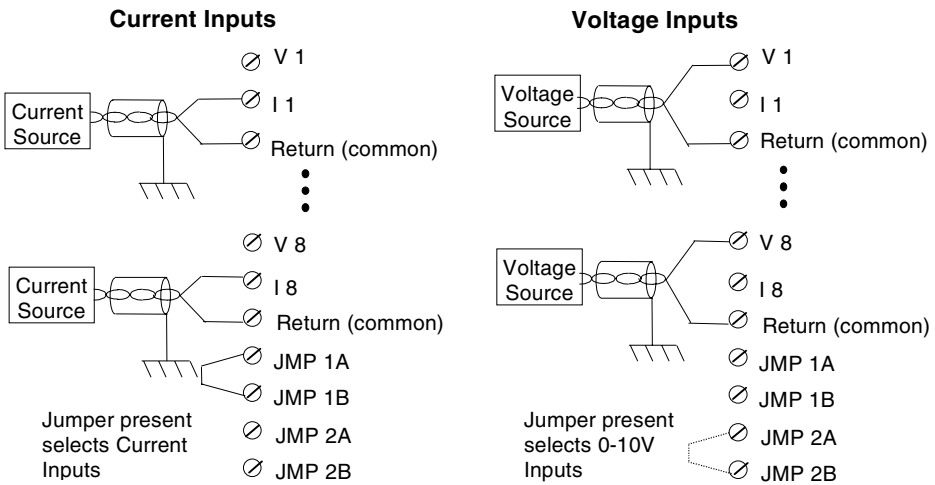

An external source must be provided to power input transceivers.

Cable Shield Connections

If possible, the cable should be grounded at the source device. If that is not possible, the cable shield must be grounded at the source device. If that is not possible, the cable shield must be grounded at the I/O module. This can be done using an Auxiliary I/O Terminal (IC200TBM001, 002, or 005).

If the module is installed on a Terminal-style I/O Carrier (IC200CHS001, 002, or 005), shield connections can be made on an Auxiliary I/O Terminal that is attached to the I/O carrier.

If the module is installed on a Compact Terminal-style I/O Carrier (IC200CHS022, 025), shield connections can be made on an Auxiliary I/O Terminal that is mounted near the I/O carrier. Be sure to ground the Auxiliary I/O Terminal Strip if you plan to use it for this purpose.

If the module is installed on a Connector-style I/O Carrier (IC200CHS003), the cable shield can be connected directly to an Interposing Terminal (IC200CHS011, 012, 015). Be sure to ground the Interposing Terminal. It is recommended to use a shielded interposing cable as well between the Interposing Terminal and the Connector Base. A custom shielded cable can be made using the Connector kit (IC200ACC302). In addition, a custom shield braid can be wrapped around standard Interposing Cables (IC200CBL105, 110, 120, 230). If this approach is used be sure to ground the braid.

IC200ALG260
Analog Input Module, 12 Bit Voltage/Current 8 Channels

Scaling

The graphs below show the relationship between the input voltage or current measured at the field terminals and the data that is output by the module.

Count and Input Current

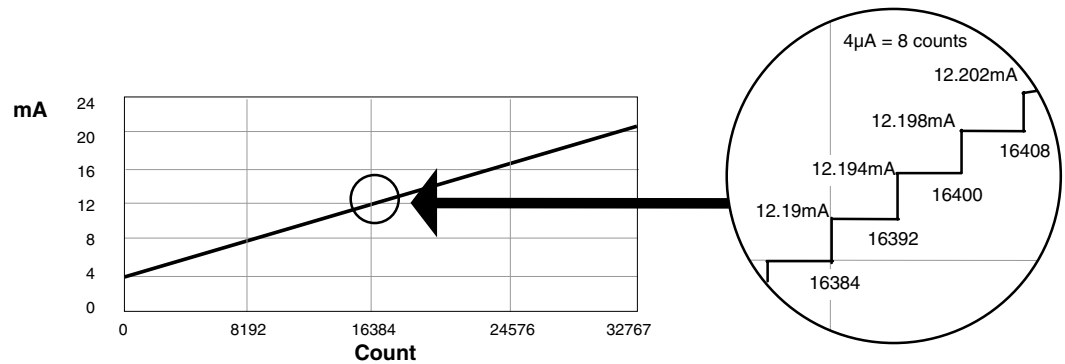

The following equation can be used to calculate counts values:

$$\text{Counts} = (\text{Current in mA} - 4\text{mA}) \times (32768 / 16.38\text{mA})$$

For a change in the reported count value to be seen, input current must be increased by at least 2.5mV. If the module receives an increase less than 2.5mV, the previous count value is still reported. For example:

Current	Count
12.190mA	16384
12.192mA	16384
12.199mA	16392

IC200ALG260

Analog Input Module, 12 Bit Voltage/Current 8 Channels

Count and Input Voltage

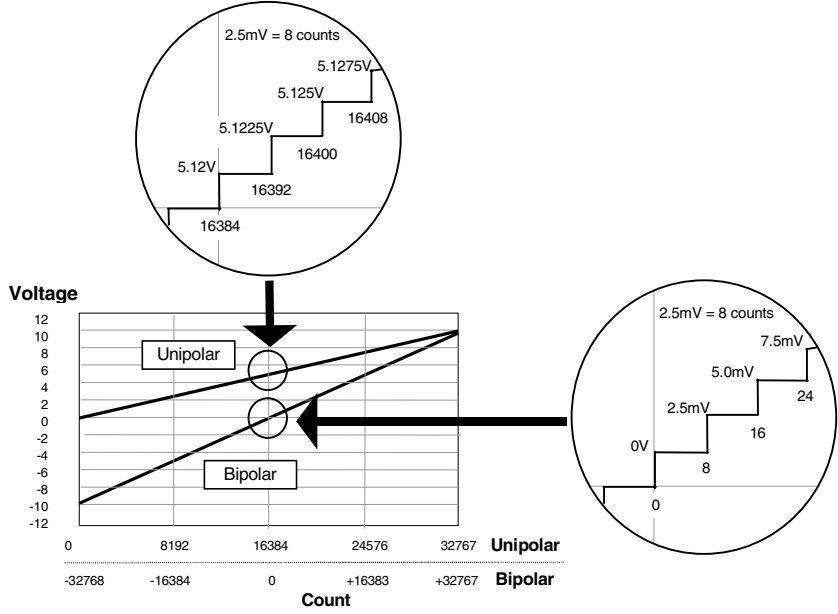

The following equations can be used to calculate counts values:

Bipolar voltage: Counts = (±Voltage In) x (3200)

Unipolar voltage: Counts = (+Voltage In) x (3200)

For a change in the reported count value to be seen, input current must be increased by at least 2.5mV. If the module receives an increase less than 2.5mV, the previous count value is still reported. For example:

Voltage	Count
5.1200V	16384
5.1220V	16384
5.1225V	16392

IC200ALG261 **Analog Input Module, 15 Bit Differential Voltage 8 Channels**

Analog input module IC200ALG261 provides an interface to 8 differential voltage inputs.

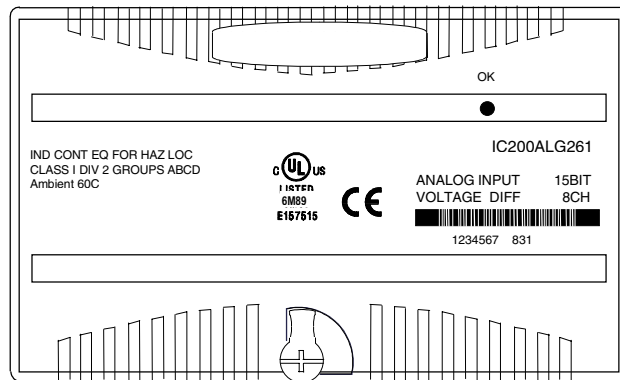

The module receives power from the backplane power supply. No external power source is required for module operation. Power for the user's transceivers must be supplied from an external source.

Intelligent processing for this module is performed by the CPU or NIU. The module provides 8 words of analog input data.

LED Indicators

The green OK LED is on when backplane power is present, internally generated field power is functioning properly, the module has been configured, and the module has been recognized on the backplane.

Diagnostics

The module reports a Loss of Internal Power fault for field-side circuits.

Configuration Parameters

None

IC200ALG261

Analog Input Module, 15 Bit Differential Voltage 8 Channels

Module Specifications

Module Characteristics	
Channels	8 differential, one group
Module ID	FFFFB008
Isolation: User input to logic (optical) and to frame ground	250VAC continuous; 1500VAC for 1 minute
Group to group	Not applicable
Channel to channel	None
LED indicators	OK LED indicates backplane power is present
Backplane current consumption	5V output: 200mA maximum
External power supply	None
Thermal derating	None
Configuration parameters	None
Diagnostics	Loss of Internal Power
Input Characteristics	
Input Voltage (Differential)	-10V to +10V
Input Voltage (Common Mode)	-10V to +10V
Input Impedance	100K ohms minimum
Accuracy (0V common mode): 25 degrees C* 0 to 60 degrees C	+/-0.3% typical of full scale, +/-0.5% maximum of full scale +/-1% maximum of full scale
Resolution	0.3125mV = 1 count
Common mode rejection	70db
Update rate per module	7.5ms
Compatibility	
VersaPro Software	Version 2.0 or higher
VersaMax PLC CPU Firmware	Version 2.10 or higher
VersaMax Ethernet NIU Firmware	Version 1.10 or higher
VersaMax DeviceNet, Profibus, or Genius NIU Firmware	Planned for future release

* In the presence of severe RF interference, (IEC 1000-4-3, 10V/m), accuracy may be degraded to +/-1%. Input accuracy may be degraded an additional +/-1% with the introduction of input common mode voltage.

IC200ALG261
Analog Input Module, 15 Bit Differential Voltage 8 Channels

Field Wiring

Terminal assignments for the module are shown below.

Number	Connection	Number	Connection
A1	Input 1 (+)	B1	No connection
A2	Input 1 (-)	B2	No connection
A3	Input 2 (+)	B3	No connection
A4	Input 2 (-)	B4	No connection
A5	Input 3 (+)	B5	No connection
A6	Input 3 (-)	B6	No connection
A7	Input 4 (+)	B7	No connection
A8	Input 4 (-)	B8	No connection
A9	Input 5 (+)	B9	No connection
A10	Input 5 (-)	B10	No connection
A11	Input 6 (+)	B11	No connection
A12	Input 6 (-)	B12	No connection
A13	Input 7 (+)	B13	No connection
A14	Input 7 (-)	B14	No connection
A15	Input 8 (+)	B15	No connection
A16	Input 8 (-)	B16	No connection
A17	Field Return	B17	No connection
A18	NC	B18	No connection

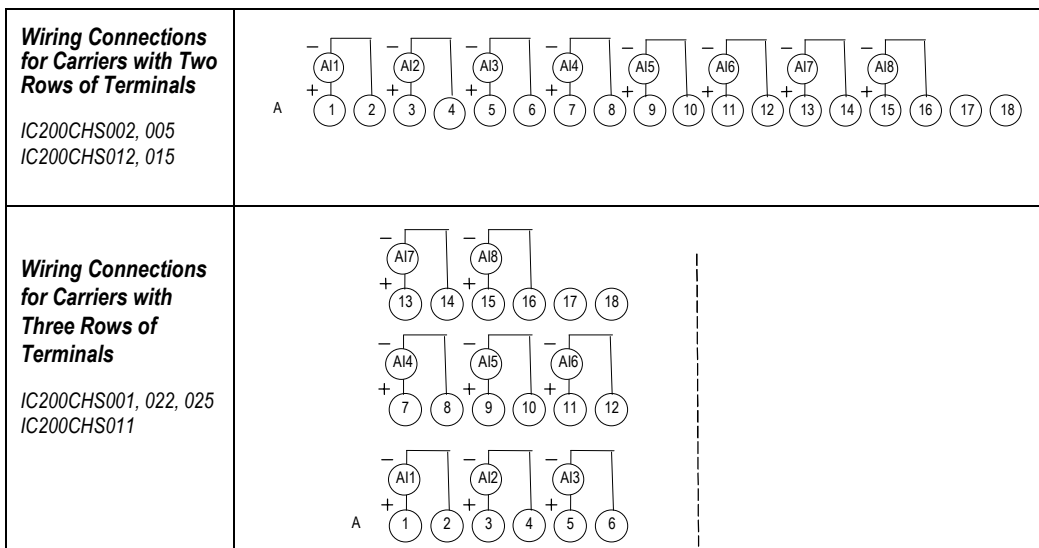

IC200ALG261

Analog Input Module, 15 Bit Differential Voltage 8 Channels

Wiring Examples

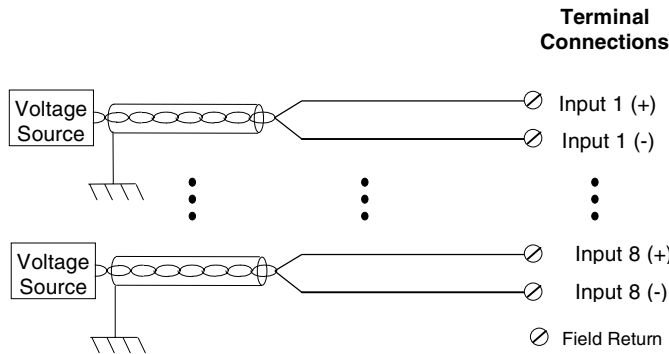

An external source must be provided to power input transceivers.

Cable Shield Connections

If possible, the cable should be grounded at the source device. If that is not possible, the cable shield must be grounded at the source device. If that is not possible, the cable shield must be grounded at the I/O module. This can be done using an Auxiliary I/O Terminal (IC200TBM001, 002, or 005).

If the module is installed on a Terminal-style I/O Carrier (IC200CHS001, 002, or 005), shield connections can be made on an Auxiliary I/O Terminal that is attached to the I/O carrier.

If the module is installed on a Compact Terminal-style I/O Carrier (IC200CHS022, 025), shield connections can be made on an Auxiliary I/O Terminal that is mounted near the I/O carrier. Be sure to ground the Auxiliary I/O Terminal Strip if you plan to use it for this purpose.

If the module is installed on a Connector-style I/O Carrier (IC200CHS003), the cable shield can be connected directly to an Interposing Terminal (IC200CHS011, 012, 015). Be sure to ground the Interposing Terminal. It is recommended to use a shielded interposing cable as well between the Interposing Terminal and the Connector Base. A custom shielded cable can be made using the Connector kit (IC200ACC302). In addition, a custom shield braid can be wrapped around standard Interposing Cables (IC200CBL105, 110, 120, 230). If this approach is used be sure to ground the braid.

IC200ALG261
Analog Input Module, 15 Bit Differential Voltage 8 Channels

Scaling

The graphs below show the relationship between the input voltage measured at the field terminals and the data that is output by the module.

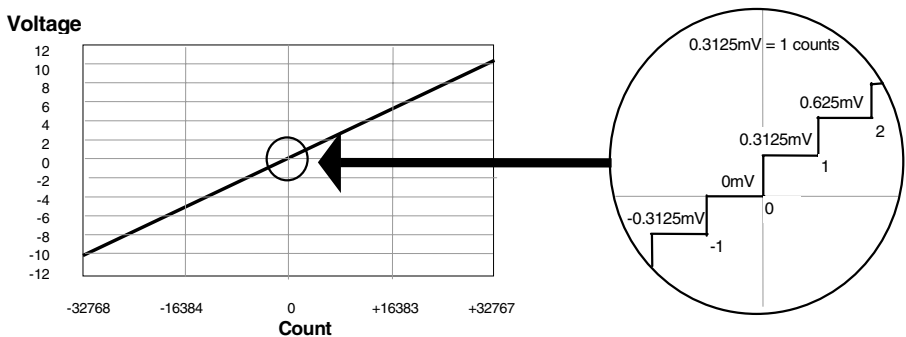

The following equations can be used to calculate count values:

$$\text{Counts} = (\text{Input Voltage}) \times (32000 / 10\text{V})$$

Operating Range

The operating range for the IC200ALG261 module is shown in the following graph.

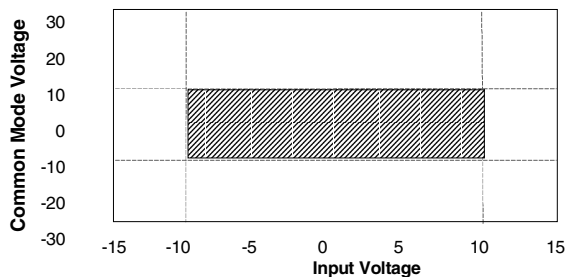

IC200ALG262

Analog Input Module, 15 Bit Differential Current 8 Channels

Analog input module IC200ALG262 provides an interface to 8 current inputs.

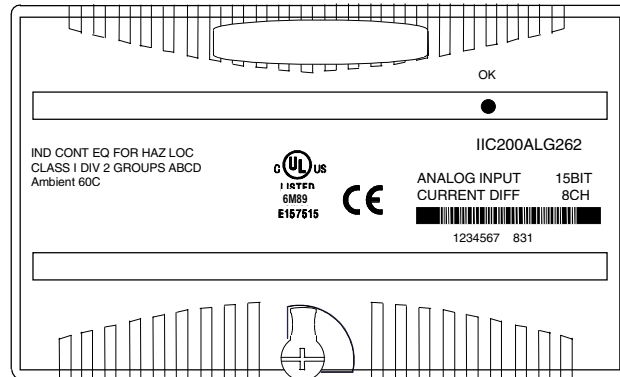

The module receives power from the backplane power supply. No external power source is required for module operation. Power for the user's transceivers must be supplied from an external source.

Intelligent processing for this module is performed by the CPU or NIU. The module provides 8 words of analog input data.

LED Indicators

The green OK LED is on when backplane power is present, internally generated field power is functioning properly, the module has been configured, and the module has been recognized on the backplane.

Diagnostics

The module reports a Loss of Internal Power fault for field-side circuits.

The module reports an Open Wire fault for each channel, when in 4-20mA mode.

Configuration Parameters

A jumper on the carrier terminals can be used to configure 4-20mA or 0-20mA input ranges. With no jumper installed, the module accepts 4-20mA input signals. With a jumper installed, the module accepts 0-20mA input signals.

IC200ALG262
Analog Input Module, 15 Bit Differential Current 8 Channels

Module Specifications

Module Characteristics	
Channels	8 differential, one group
Module ID	FFFFB508 (when configured for 4-20mA range) FFFFB408 (when configured for 0-20mA range)
Isolation:	
User input to logic (optical) and to frame ground	250VAC continuous; 1500VAC for 1 minute
Group to group	Not applicable
Channel to channel	None
LED indicators	OK LED indicates backplane power is present
Backplane current consumption	5V output: 200mA maximum
External power supply	None
Thermal derating	None
Configuration parameters	Range select (jumpers on carrier)
Diagnostics	Loss of Internal Power, Open wire detection of 4-20mA signals only
Input Characteristics	
Input current	4 to 20mA (default : no terminal jumper installed) 0 to 20mA (with terminal jumper installed)
Common Mode Range	-10V to +10V
Common mode rejection	70db
Input Impedance	100 Ohms
Accuracy (0V Common Mode): 25 degrees C* 0 to 60 degrees C	+/-0.3% typical of full scale, +/-0.5% maximum of full scale +/-1% maximum of full scale
Resolution	0.5 μ A = 1 counts (for 4-20mA range) 0.625 μ A = 1 counts (for 0-20mA range)
Update rate per module	7.5ms
Compatibility	
VersaPro Software	Version 2.0 or higher
VersaMax PLC CPU Firmware	Version 2.10 or higher
VersaMax Ethernet NIU Firmware	Version 1.10 or higher
VersaMax DeviceNet, Profibus, or Genius NIU Firmware	Planned for future release

* In the presence of severe RF interference, (IEC 1000-4-3, 10V/m), accuracy may be degraded to +/-1%. Input accuracy may be degraded an additional +/-3% with the introduction of input common mode voltage.

IC200ALG262

Analog Input Module, 15 Bit Differential Current 8 Channels

Field Wiring

Terminal assignments for the module are shown below.

Number	Connection	Number	Connection
A1	Input 1 (+)	B1	No connection
A2	Input 1 (-)	B2	No connection
A3	Input 2 (+)	B3	No connection
A4	Input 2 (-)	B4	No connection
A5	Input 3 (+)	B5	No connection
A6	Input 3 (-)	B6	No connection
A7	Input 4 (+)	B7	No connection
A8	Input 4 (-)	B8	No connection
A9	Input 5 (+)	B9	No connection
A10	Input 5 (-)	B10	No connection
A11	Input 6 (+)	B11	No connection
A12	Input 6 (-)	B12	No connection
A13	Input 7 (+)	B13	No connection
A14	Input 7 (-)	B14	No connection
A15	Input 8 (+)	B15	No connection
A16	Input 8 (-)	B16	No connection
A17	Field Return	B17	No connection
A18	Jumper	B18	No connection

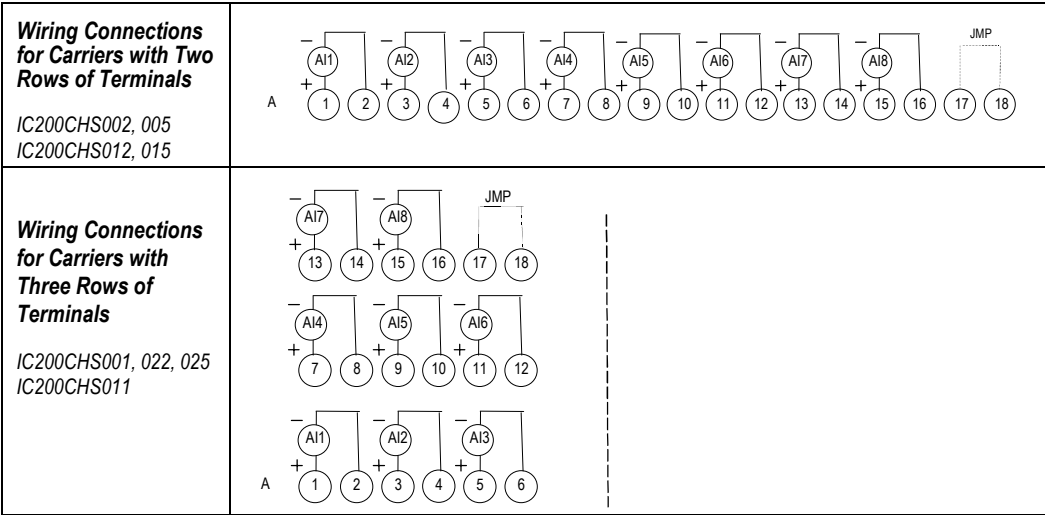

**IC200ALG262
Analog Input Module, 14 Bit Differential Current 8 Channels**

Jumper Selections

A jumper selects the current input range.

Jumper	Range
None	4-20mA
Installed from A18 to A17	0-20mA

Wiring Examples

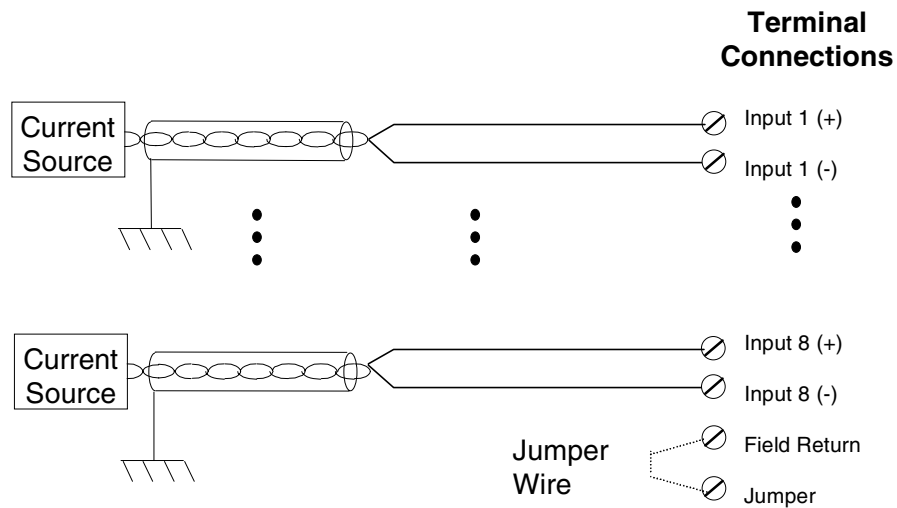

An external source must be provided to power input transceivers.

Cable Shield Connections

If possible, the cable should be grounded at the source device. If that is not possible, the cable shield must be grounded at the source device. If that is not possible, the cable shield must be grounded at the I/O module. This can be done using an Auxiliary I/O Terminal (IC200TBM001, 002, or 005).

If the module is installed on a Terminal-style I/O Carrier (IC200CHS001, 002, or 005), shield connections can be made on an Auxiliary I/O Terminal that is attached to the I/O carrier.

If the module is installed on a Compact Terminal-style I/O Carrier (IC200CHS022, 025), shield connections can be made on an Auxiliary I/O Terminal that is mounted near the I/O carrier. Be sure to ground the Auxiliary I/O Terminal Strip if you plan to use it for this purpose.

If the module is installed on a Connector-style I/O Carrier (IC200CHS003), the cable shield can be connected directly to an Interposing Terminal (IC200CHS011, 012, 015). Be sure to ground the Interposing Terminal. It is recommended to use a shielded interposing cable as well between the Interposing Terminal and the Connector Base. A custom shielded cable can be made using the Connector kit (IC200ACC302). In addition, a custom shield braid can be wrapped around standard Interposing Cables (IC200CBL105, 110, 120, 230). If this approach is used be sure to ground the braid.

IC200ALG262
Analog Input Module, 15 Bit Differential Current 8 Channels

Scaling

The illustration below shows the relationship between the input current measured at the field terminals and the data that is output by the module.

Count and 4-20mA Input Current

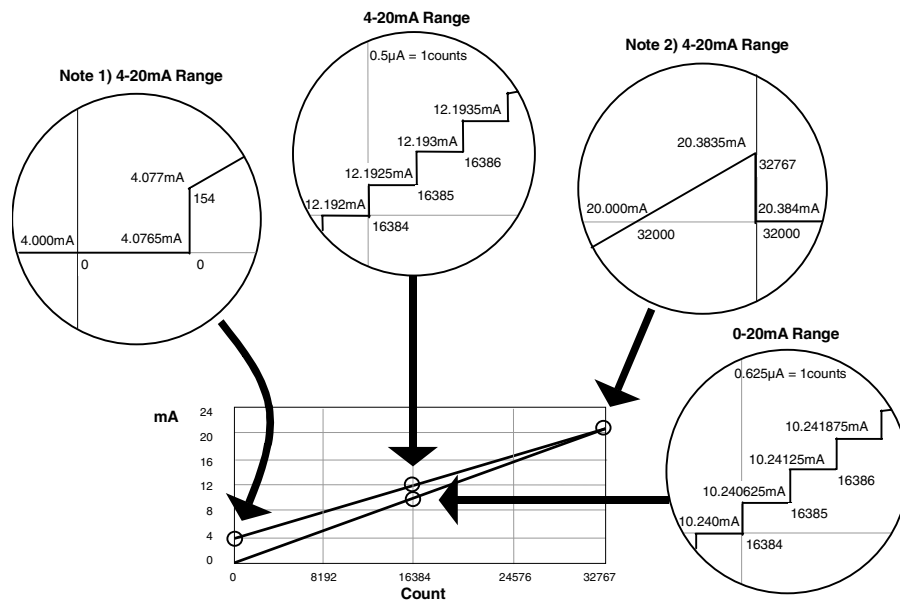

The following equations can be used to calculate count values:

4-20mA Range: Counts = (Current in mA - 4mA) x (32000 / 16mA)
 0-20mA Range: Counts = (Current in mA) x (32000 / 20mA)

Note 1) In 4-20mA mode, signal inputs below 4.077mA are converted to zero counts.

Note 2) In 4-20mA mode, signal inputs at 20.000mA or above 20.383mA are converted to 32000 counts.

The count value must be a multiple of 4. If the module receives a count value that is not a multiple of 4, It rounds the value down to the closest multiple of 4. For example, in 4-20mA mode:

Count	mA
16000	12.000
16003	12.000
16004	12.002

IC200ALG262
Analog Input Module, 15 Bit Differential Current 8 Channels

Operating Range

The operating range for the IC200ALG262 module is shown in the following graph.

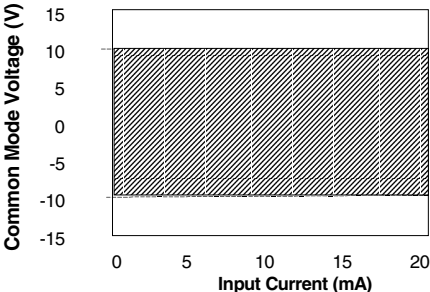

IC200ALG263 Analog Input Module, 15 Bit Voltage 15 Channels

Analog input module IC200ALG263 provides an interface to 15 voltage inputs. The inputs are single-ended, with all inputs sharing a common return.

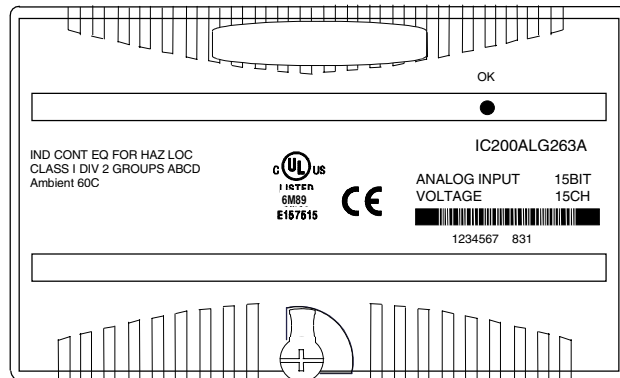

The module receives power from the backplane power supply. No external power source is required for module operation. Power for the user's transceivers must be supplied from an external source.

Intelligent processing for this module is performed by the CPU or NIU. The module provides 15 words of analog input data.

LED Indicators

The green OK LED is on when backplane power is present, internally generated field power is functioning properly, the module has been configured, the module has been recognized on the backplane, and all diagnostic tests are executing as expected.

Diagnostics

The module reports a Loss of Internal Power fault for field-side circuits.

The module reports an Internal Hardware fault upon detection of an A/D conversion malfunction. The module detects this malfunction by applying a known stimulus to the A/D conversion path and verifying the expected result. If an unexpected result occurs three times consecutively, the module stops scanning, turns off the OK LED, and reports an Internal Hardware fault. The module must be power cycled or replaced to clear this fault.

Configuration Parameters

The analog inputs are software-configurable to either default or hold last state upon loss of module.

IC200ALG263
Analog Input Module, 15 Bit Voltage 15 Channels

Module Specifications

Module Characteristics	
Channels	15 single ended, one group
Module ID	FFFFB00F
Isolation: User input to logic (optical) and to frame ground	250VAC continuous; 1500VAC for 1 minute
Group to group	Not applicable
Channel to channel	None
LED indicators	OK LED. See "LED Indicators" for description.
Backplane current consumption	5V output: 150mA maximum
External power supply	None
Thermal derating	None
Configuration parameters	None
Diagnostics	Loss of Internal Power A/D conversion malfunction greater than 6% of full scale
Input Characteristics	
Input voltage	-10V to +10V
Input Impedance	100K Ohms minimum
Accuracy at: 25 degrees C* 0 to 60 degrees C	+/-0.3% typical of full scale, +/-0.5% maximum of full scale +/-1% maximum of full scale
Resolution	+/- 15 bits 0.3125mV = 1 count
Filter response (3dB Corner Freq)	32 Hz +/-20%
Update rate per module	7.5ms
Compatibility	
VersaPro Software	Version 2.0 or higher
VersaMax PLC CPU Firmware	Version 2.10 or higher
VersaMax Ethernet NIU Firmware	Version 1.10 or higher
VersaMax DeviceNet, Profibus, or Genius NIU Firmware	Planned for future release

* In the presence of severe RF interference, (IEC 1000-4-3, 10V/m), accuracy may be degraded to +/-2%.

IC200ALG263
Analog Input Module, 15 Bit Voltage 15 Channels

Field Wiring

Terminal assignments for the module are shown below.

Number	Connection	Number	Connection
A1	V1	B1	No connection
A2	V2	B2	No connection
A3	V3	B3	No connection
A4	V4	B4	No connection
A5	V5	B5	No connection
A6	V6	B6	No connection
A7	V7	B7	No connection
A8	V8	B8	No connection
A9	V9	B9	No connection
A10	V10	B10	No connection
A11	V11	B11	No connection
A12	V12	B12	No connection
A13	V13	B13	No connection
A14	V14	B14	No connection
A15	V15	B15	No connection
A16	NC	B16	No connection
A17	Return (common)	B17	No connection
A18	NC	B18	No connection

Note: All inputs are single-ended, and share a common return.

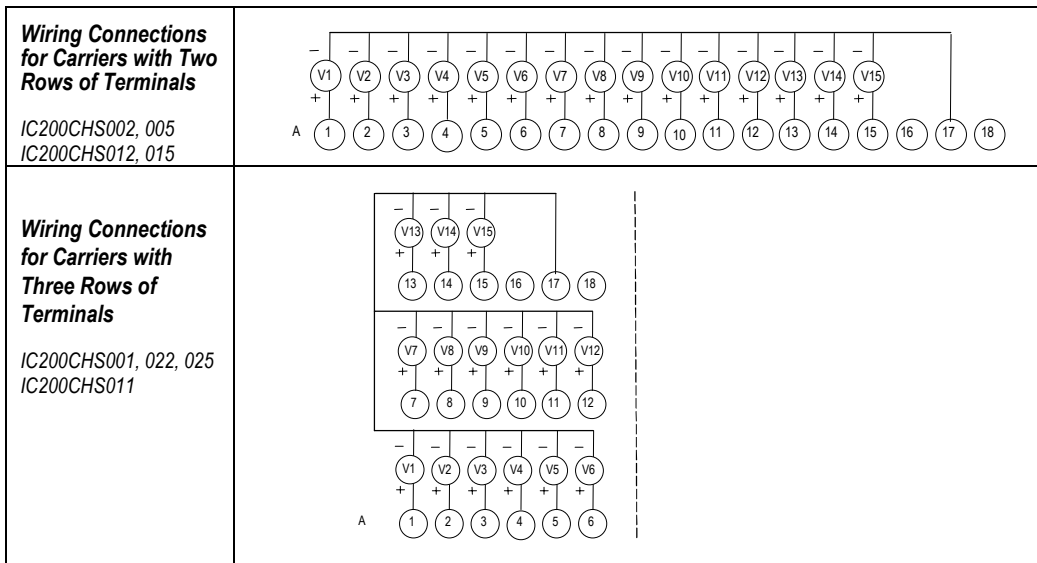

IC200ALG263

Analog Input Module, 15 Bit Voltage 15 Channels

Wiring Examples

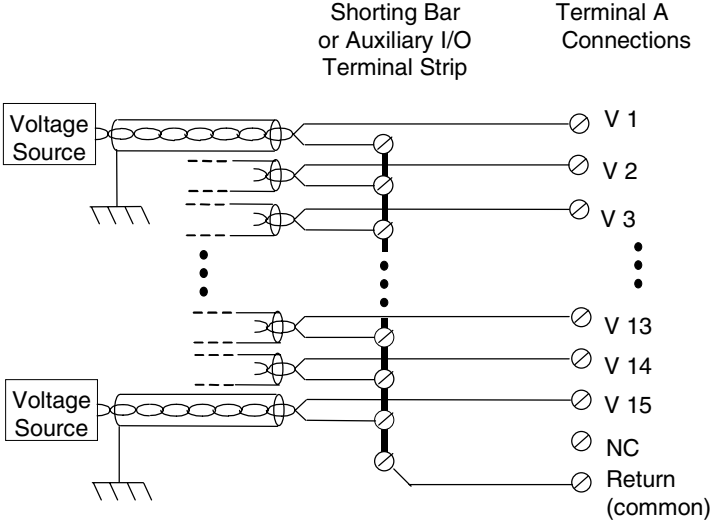

An optional Shorting Bar or Auxiliary I/O Terminal Strip can be used for wiring convenience when multiple Return paths need to be wired together.

An external source must be provided to power input transceivers.

IC200ALG263
Analog Input Module, 15 Bit Voltage 15 Channels**Cable Shield Connections**

If possible, the cable should be grounded at the source device. If that is not possible, the cable shield must be grounded at the source device. If that is not possible, the cable shield must be grounded at the I/O module. This can be done using an Auxiliary I/O Terminal (IC200TBM001, 002, or 005).

If the module is installed on a Terminal-style I/O Carrier (IC200CHS001, 002, or 005), shield connections can be made on an Auxiliary I/O Terminal that is attached to the I/O carrier.

If the module is installed on a Compact Terminal-style I/O Carrier (IC200CHS022, 025), shield connections can be made on an Auxiliary I/O Terminal that is mounted near the I/O carrier. Be sure to ground the Auxiliary I/O Terminal Strip if you plan to use it for this purpose.

If the module is installed on a Connector-style I/O Carrier (IC200CHS003), the cable shield can be connected directly to an Interposing Terminal (IC200CHS011, 012, 015). Be sure to ground the Interposing Terminal. It is recommended to use a shielded interposing cable as well between the Interposing Terminal and the Connector Base. A custom shielded cable can be made using the Connector kit (IC200ACC302). In addition, a custom shield braid can be wrapped around standard Interposing Cables (IC200CBL105, 110, 120, 230). If this approach is used be sure to ground the braid.

IC200ALG263

Analog Input Module, 15 Bit Voltage 15 Channels

Scaling

The graphs below show the relationship between the input voltage measured at the field terminals and the data that is output by the module.

Count and Input Voltage

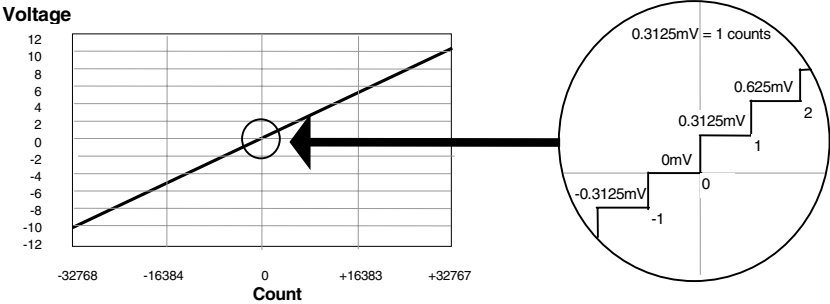

The following equation can be used to calculate count values:

$$\text{Counts} = (\text{Input Voltage}) \times (32000 / 10V)$$

IC200ALG264 **Analog Input Module, 15 Bit Current 15 Channels**

Analog input module IC200ALG264 provides an interface to 15 current inputs. The inputs are single-ended, with all inputs sharing a common return.

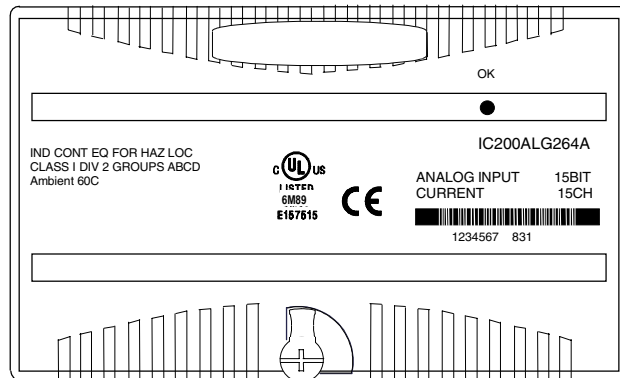

The module receives power from the backplane power supply. No external power source is required for module operation. Power for the user's transceivers must be supplied from an external source.

Intelligent processing for this module is performed by the CPU or NIU. The module provides 15 words of analog input data.

LED Indicators

The green OK LED is on when backplane power is present, internally generated field power is functioning properly, the module has been configured, and the module has been recognized on the backplane.

Diagnostics

The module reports a Loss of Internal Power fault for field-side circuits.

The module reports an Open Wire fault for each channel, when in 4-20mA mode.

Configuration Parameters

A jumper on the carrier terminals can be used to configure 4-20mA or 0-20mA input ranges. With no jumper installed, the module accepts 4-20mA input signals. With a jumper installed, the module accepts 0-20mA input signals.

The analog inputs are software-configurable to either default or hold last state upon loss of module.

IC200ALG264

Analog Input Module, 15 Bit Current 15 Channels

Module Specifications

Module Characteristics	
Channels	15 single ended, one group
Module ID	FFFFB50F (when cfg for 4-20mA range) FFFFB40F (when cfg for 0-20mA range)
Isolation: User input to logic (optical) and to frame ground	250VAC continuous; 1500VAC for 1 minute
Group to group	Not applicable
Channel to channel	None
LED indicators	OK LED. See "LED Indicators" for description.
Backplane current consumption	5V output: 100mA maximum
External power supply	None
Thermal derating	None
Configuration parameters	Range select (jumpers on carrier)
Diagnostics	Loss of Internal Power, Open wire detection of 4-20mA signals only
Input Characteristics	
Input current	4 to 20mA (default : no terminal jumper installed) 0 to 20mA (with terminal jumper installed)
Input Impedance	100 Ohms
Accuracy at: 25 degrees C* 0 to 60 degrees C (See Notes 1, 2, & 3)	+/-0.3% typical of full scale, +/-0.5% maximum of full scale +/-1% maximum of full scale
Resolution	15 bits 0.5µA = 1 counts (for 4-20mA range) 0.625µA = 1 counts (for 0-20mA range)
Filter response (3dB Corner Freq)	24 Hz +/-20%
Update rate per module	7.5ms
Compatibility	
VersaPro Software	Version 2.0 or higher
VersaMax PLC CPU Firmware	Version 2.10 or higher
VersaMax Ethernet NIU Firmware	Version 1.10 or higher
VersaMax DeviceNet, Profibus, or Genius NIU Firmware	Planned for future release

* In the presence of severe RF interference, (IEC 1000-4-3, 10V/m), accuracy may be degraded to +/-2%.

IC200ALG264
Analog Input Module, 15 Bit Current 15 Channels

Field Wiring

Terminal assignments for the module are shown below.

Number	Connection	Number	Connection
A1	I1	B1	No connection
A2	I2	B2	No connection
A3	I3	B3	No connection
A4	I4	B4	No connection
A5	I5	B5	No connection
A6	I6	B6	No connection
A7	I7	B7	No connection
A8	I8	B8	No connection
A9	I9	B9	No connection
A10	I10	B10	No connection
A11	I11	B11	No connection
A12	I12	B12	No connection
A13	I13	B13	No connection
A14	I14	B14	No connection
A15	I15	B15	No connection
A16	Range JMPR	B16	No connection
A17	Return (common)	B17	No connection
A18	NC	B18	No connection

Note: All inputs are single-ended, and share a common return.

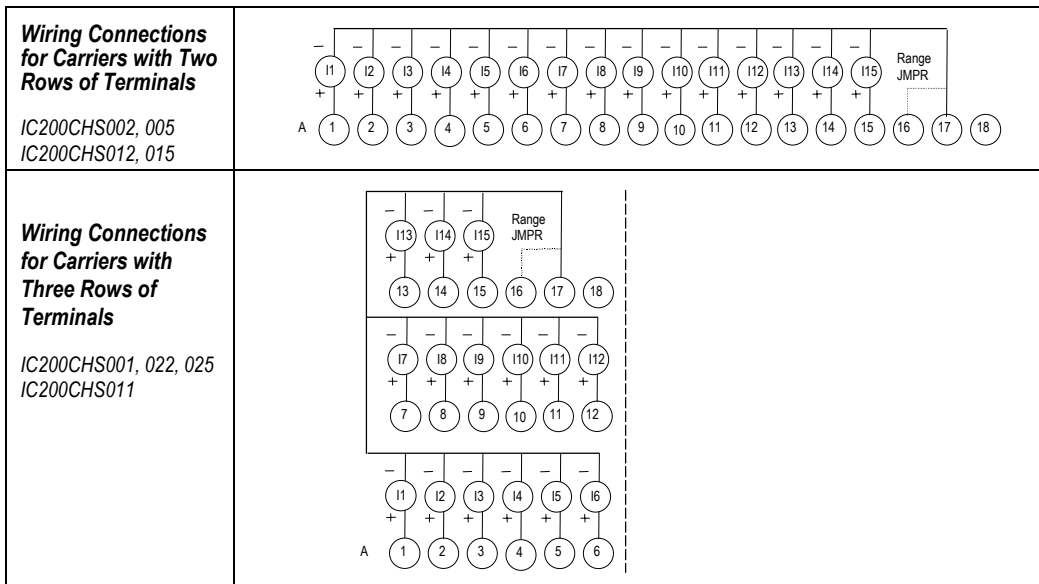

IC200ALG264
Analog Input Module, 15 Bit Current 15Channels

Jumper Selections

A jumper selects the current input range.

Jumper	Range
None	4-20mA
Installed from A16 to A17	0-20mA

Wiring Examples

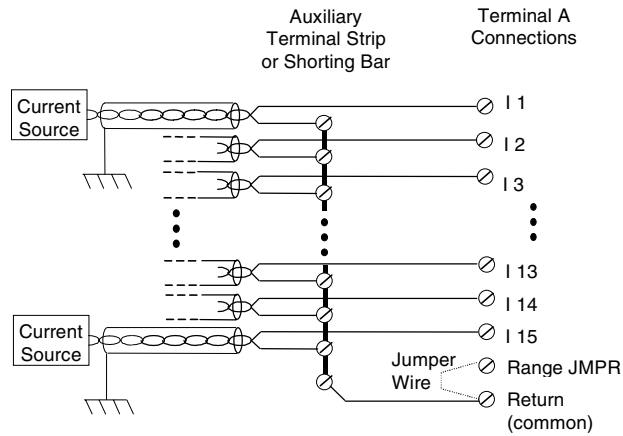

An optional Auxiliary I/O Terminal Strip or Shorting Bar can be used for wiring convenience, when multiple Return paths need to be wired together.

An external source must be provided to power input transceivers.

IC200ALG264
Analog Input Module, 15 Bit Current 15 Channels**Cable Shield Connections**

If possible, the cable should be grounded at the source device. If that is not possible, the cable shield must be grounded at the source device. If that is not possible, the cable shield must be grounded at the I/O module. This can be done using an Auxiliary I/O Terminal (IC200TBM001, 002, or 005).

If the module is installed on a Terminal-style I/O Carrier (IC200CHS001, 002, or 005), shield connections can be made on an Auxiliary I/O Terminal that is attached to the I/O carrier.

If the module is installed on a Compact Terminal-style I/O Carrier (IC200CHS022, 025), shield connections can be made on an Auxiliary I/O Terminal that is mounted near the I/O carrier. Be sure to ground the Auxiliary I/O Terminal Strip if you plan to use it for this purpose.

If the module is installed on a Connector-style I/O Carrier (IC200CHS003), the cable shield can be connected directly to an Interposing Terminal (IC200CHS011, 012, 015). Be sure to ground the Interposing Terminal. It is recommended to use a shielded interposing cable as well between the Interposing Terminal and the Connector Base. A custom shielded cable can be made using the Connector kit (IC200ACC302). In addition, a custom shield braid can be wrapped around standard Interposing Cables (IC200CBL105, 110, 120, 230). If this approach is used be sure to ground the braid.

IC200ALG264
Analog Input Module, 15 Bit Current 15 Channels

Scaling

The graphs below show the relationship between the input current measured at the field terminals and the data that is output by the module.

Count and 4-20mA Input Current

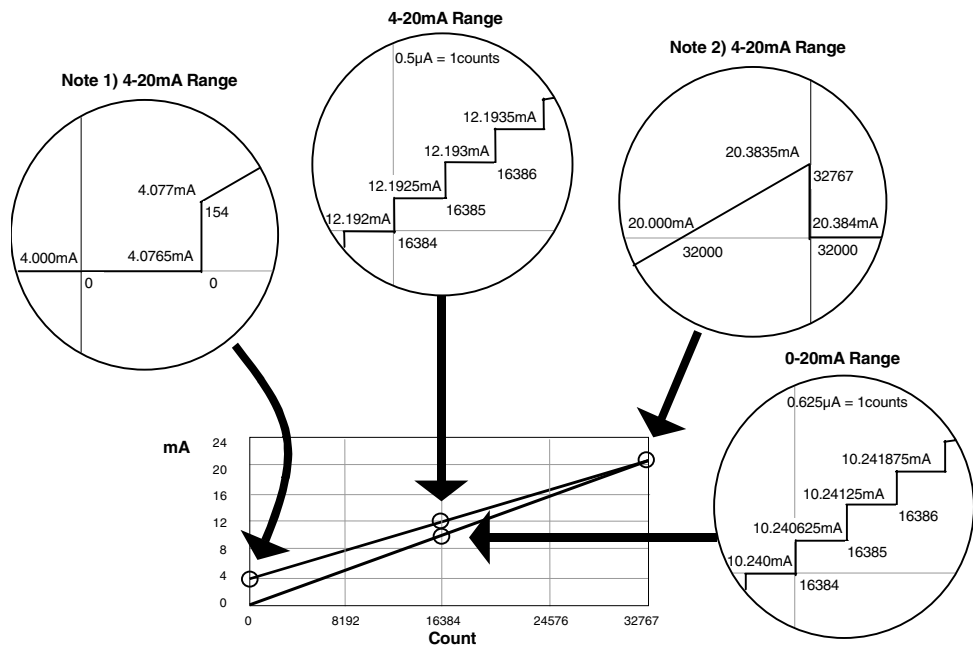

The following equations can be used to calculate count values:

4-20mA Range: Counts = (Current in mA - 4mA) x (32000 / 16mA)

0-20mA Range: Counts = (Current in mA) x (32000 / 20mA)

Note 1) In 4-20mA mode, signal inputs below 4.077mA are converted to zero counts.

Note 2) In 4-20mA mode, signal inputs at 20.000mA or above 20.383mA are converted to 32000 counts

Chapter 11

Analog Output Modules

This chapter describes VersaMax analog output modules.

- IC200ALG320 Analog Output Module, 12 Bit Current, 4 Channels
- IC200ALG321 Analog Output Module, 12 Bit Voltage
0 to 10VDC 4 Channels
- IC200ALG322 Analog Output Module, 12 Bit Voltage
-10 to +10VDC 4 Channels
- IC200ALG325 Analog Output Module, 13 Bit Voltage 8 Channels
- IC200ALG326 Analog Output Module, 13 Bit Current, 8 Channels
- IC200ALG327 Analog Output Module, 13 Bit Voltage, 12 Channels
- IC200ALG328 Analog Output Module, 13 Bit Current, 12 Channels
- IC200ALG331 Analog Output Module, 16 Bit Voltage/Current,
1500VAC Isolation, 4 Channels

IC200ALG320 **Analog Output Module, 12 Bit Current, 4 Channels**

Analog output module IC200ALG320 provides four 4mA to 20mA analog current-sourcing outputs. Including a modest amount of overrange current, approximately 20.38mA of output current per channel is available to drive output loads.

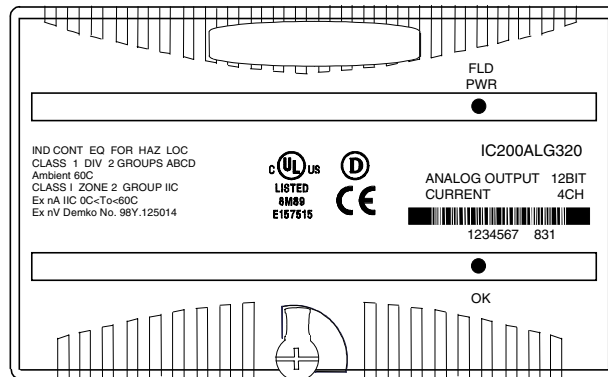

An external source of DC power is required for the outputs.

Intelligent processing for this module is performed by the CPU or NIU. The module receives 4 words of analog output data.

LED Indicators

The green FLD PWR LED indicates the presence of user-side power for the analog field-side circuits.

The green OK LED is on when backplane power is present to the module.

Diagnostics

The module reports a Loss of User Side Power fault for field-side circuits.

Configuration Parameters

The module is easily set up with a jumper for the outputs to either hold their last states or default to 4mA if backplane power or communications are interrupted or the PLC is stopped. External user power must remain uninterrupted.

Outputs remain in their default or last state until the module receives different output data from the backplane, or until field power is removed.

IC200ALG320
Analog Output Module, 12 Bit Current, 4 Channels

Module Specifications

Module Characteristics	
Channels	4 single-ended, one group
Module ID	FFFF9440
Isolation:	
User input to logic (optical) and to frame ground	250VAC continuous; 1500VAC for 1 minute
Group to group	Not applicable
Channel to channel	None
LED indicators	FLD PWR LED indicates field power is present OK LED indicates backplane power is present
Backplane current consumption	5V output: 50mA maximum
Thermal derating	See diagram
Configuration parameter	Output default
Diagnostics	Loss of User Side Power
External Power Supply	
Recommended range	+18 to +30VDC (including ripple)
Current consumption at recommended range	160mA max.(including load current)
12V operation range	9.6 to 15VDC, 12VDC nominal (including ripple)
Current consumption at 12V range	240mA max.(including load current)
Output Characteristics	
Output current	4 to 20mA
Load characteristics:	
Resistive	0 to 1250 Ohms maximum*
Capacitive	0.1μF maximum
Inductive	0.5H maximum
Accuracy at 25 deg C**	+/- 0.3% typ. of full scale, +/- 0.5% max. of full scale
Accuracy at 0 to 60 degrees C	+/-1% maximum of full scale
Resolution	4μA = 8 counts
Update rate per module	0.3ms maximum
Channel-to-channel crosstalk rejection	70dB minimum
Output default	Hold Last State (default) 4mA (configurable)

$$* R_{L(MAX)} = (V_{EXTERNAL PS} - 4V) / 20.38mA$$

** In the presence of severe RF interference, (IEC 1000-4-3, 10V/m), accuracy may be degraded to +/-1%.

IC200ALG320
Analog Output Module, 12 Bit Current, 4 Channels

Field Wiring

Terminal	Connection	Terminal	Connection
A1	No connection	B1	No connection
A2	I OUT 1	B2	Shield Termination Point
A3	RET 1	B3	No connection
A4	No connection	B4	Shield Termination Point
A5	I OUT 2	B5	No connection
A6	RET 2	B6	Shield Termination Point
A7	No connection	B7	No connection
A8	I OUT 3	B8	Shield Termination Point
A9	RET 3	B9	No connection
A10	No connection	B10	Shield Termination Point
A11	I OUT 4	B11	No connection
A12	RET 4	B12	Shield Termination Point
A13	No connection	B13	JMP 1A
A14	No connection	B14	JMP 1B
A15	No connection	B15	No connection
A16	No connection	B16	No connection
A17	DC-	B17	No connection
A18	DC+	B18	No connection

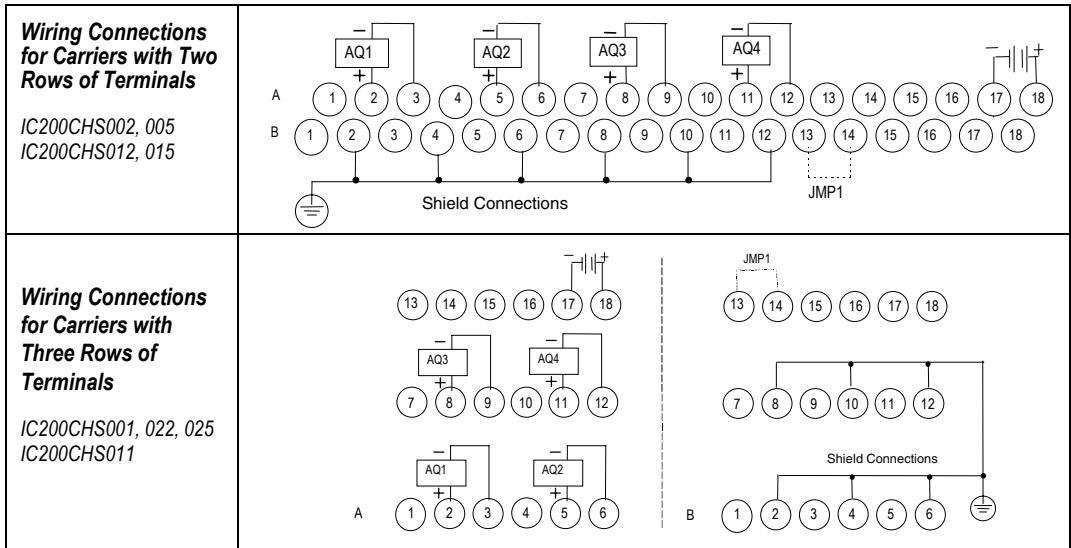

IC200ALG320
Analog Output Module, 12 Bit Current, 4 Channels

Jumper Selection

If no jumper is installed outputs hold their last state (the last commanded value from the backplane) if backplane power or communications are interrupted or the PLC is stopped. With a jumper installed, if such conditions occur outputs default to 4mA. This should only be changed with field power and backplane power removed.

Jumper	Default
None	Hold Last State
JMP 1	4mA

Wiring Example

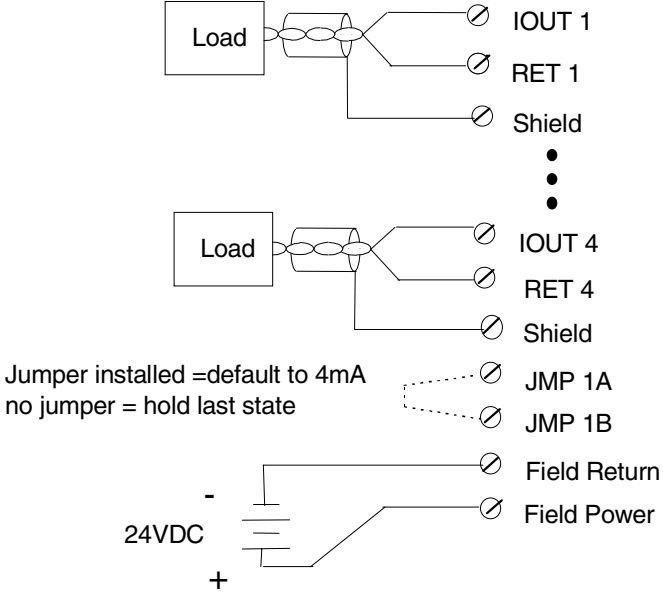

IC200ALG320
Analog Output Module, 12 Bit Current, 4 Channels**Cable Shield Connections**

Shielded twisted pair cable is recommended for all of the analog channel connections. If the module is installed on a Terminal-style I/O Carrier (IC200CHS001, 002, or 005) or a Compact Terminal-style I/O Carrier (IC200CHS022, 025), the cable shield can be connected directly to the carrier per the Field Wiring Table. An Auxiliary I/O Terminal Strip (IC200TBM001, 002, or 005) can also be added to the Terminal-style I/O Carriers to aid in grounding shields. Be sure to ground the Auxiliary I/O Terminal Strip as well if you plan to use it for this purpose.

If the module is installed on a Connector-style I/O Carrier (IC200CHS003), the cable shield can be connected directly to an Interposing Terminal (IC200CHS011, 012, 015). Be sure to ground the Interposing Terminal. It is recommended to use a shielded interposing cable as well between the Interposing Terminal and the Connector Base. A custom shielded cable can be made using the Connector kit (IC200ACC302). In addition, a custom shield braid can be wrapped around standard Interposing Cables (IC200CBL105, 110, 120, 230). If this approach is used be sure to ground the braid.

All cable shield connections should be connected to earth ground and be kept as short as practical. The power cable does not need to be shielded.

IC200ALG320
Analog Output Module, 12 Bit Current, 4 Channels

Scaling

The graph below shows the relationship between the output data that is provided to the module from the backplane, and the actual output current. The range spans between 4mA and 20mA.

Count vs Output Current

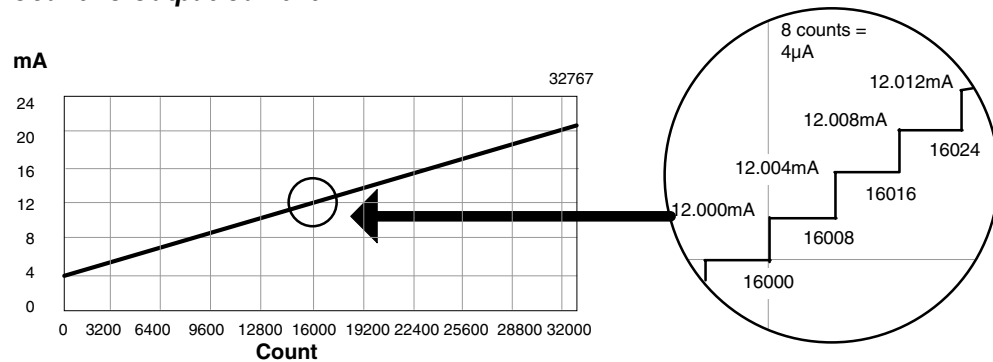

The following equation can be used to calculate specific output currents:

$$I_{\text{out}} = 4\text{mA} + (\text{count}/32760) \times 16.38\text{mA}$$

The count value must be a multiple of 8. If the module receives a count value that is not a multiple of 8, it rounds the value down to the closest multiple of 8. For example:

Count	mA
16000	12.000
16007	12.000
16008	12.004

IC200ALG320
Analog Output Module, 12 Bit Current, 4 Channels

Thermal Derating

The minimum recommended load resistance per channel depends on the ambient temperature, the external voltage, and the orientation of the module and DIN rail. The thermal derating is not affected by the type of carrier on which the module is installed.

The total load requirement includes the impedance of the transducer being driven. At higher ambient temperatures, it may be necessary to add resistance in series with the load to reach the minimum load requirement.

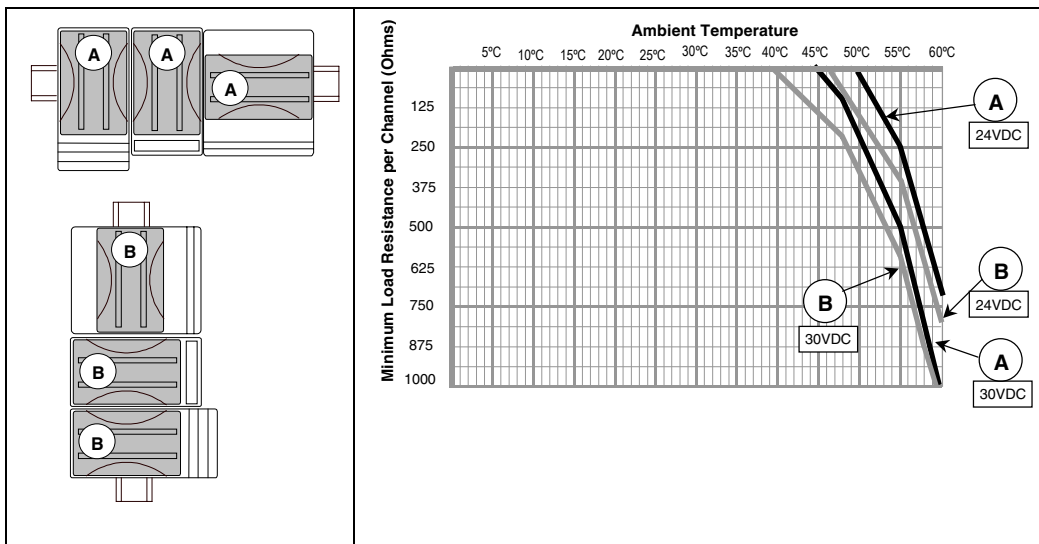

IC200ALG321

Analog Output Module, 12 Bit Voltage 0 to 10VDC 4 Channels

Analog output module IC200ALG321 provides four analog voltage outputs. The output range is 0 to +10VDC

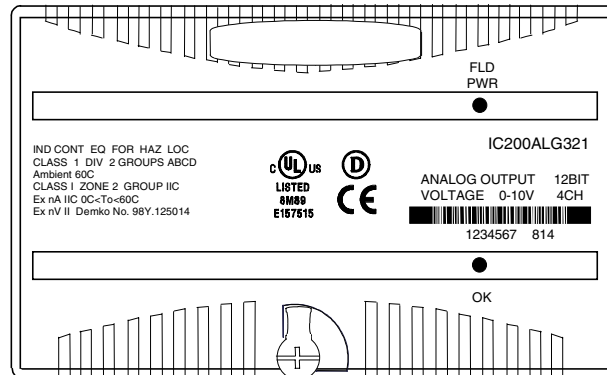

An external 24V power supply is required for the outputs.

Intelligent processing for this module is performed by the CPU or Network Interface Unit. The module receives 4 words of analog output data.

LED Indicators

The green FLD PWR LED indicates the presence of user-side power for the analog field-side circuits.

The green OK LED is on when backplane power is present to the module.

Diagnostics

The module reports a Loss of User Side Power fault for field-side circuits.

Configuration Parameters

The module is easily set up with a jumper for the outputs to either hold their last states or default to 0V if backplane power or communications are interrupted or the PLC is stopped. External user power must remain uninterrupted.

Outputs remain in their default or last state until the module receives different output data from the backplane, or until field power is removed.

IC200ALG321
Analog Output Module, 12 Bit Voltage 0 to 10VDC 4 Channels

Module Specifications

Module Characteristics	
Channels	4 single-ended, one group
Module ID	FFFF9040
Isolation:	
User input to logic (optical) and to frame ground	250VAC continuous; 1500VAC for 1 minute
Group to group	Not applicable
Channel to channel	None
LED indicators	FLD PWR LED indicates field power is present OK LED indicates backplane power is present
Backplane current consumption	5V output: 50mA maximum
Thermal derating	None
Configuration parameters	Output default
Diagnostics	Loss of User Side Power
External Power Supply	
Recommended range	+18 to +30VDC (including ripple)
Current consumption at recommended range	160mA max.(including load current)
12V operation range	9.6 to 15VDC, 12VDC nominal (including ripple)
Current consumption at 12V range	210mA max.(including load current)
Output Characteristics	
Output voltage	0 to 10.24VDC
Load characteristics:	
Resistive	5000 Ohms minimum
Capacitive	1.0 μ F maximum
Accuracy at 25 degrees C*	+/- 0.3% typ. of full scale, +/- 0.5% max. of full scale
Accuracy at 0 to 60 degrees C	+/-1% maximum of full scale
Resolution	2.5mV = 8 counts
Update rate per module	0.3ms maximum
Channel-to-channel crosstalk rejection	70dB minimum
Output default	Hold Last State (default) 0 (configurable)

* In the presence of severe RF interference, (IEC 1000-4-3, 10V/m), accuracy may be degraded to +/-1%.

IC200ALG321

Analog Output Module, 12 Bit Voltage 0 to 10VDC 4 Channels

Field Wiring

Terminal	Connection	Terminal	Connection
A1	No connection	B1	No connection
A2	V OUT 1	B2	Shield Termination Point
A3	RET 1	B3	No connection
A4	No connection	B4	Shield Termination Point
A5	V OUT 2	B5	No connection
A6	RET 2	B6	Shield Termination Point
A7	No connection	B7	No connection
A8	V OUT 3	B8	Shield Termination Point
A9	RET 3	B9	No connection
A10	No connection	B10	Shield Termination Point
A11	V OUT 4	B11	No connection
A12	RET 4	B12	Shield Termination Point
A13	No connection	B13	JMP1A
A14	No connection	B14	JMP1B
A15	No connection	B15	No connection
A16	No connection	B16	No connection
A17	Field Return	B17	No connection
A18	Field Power	B18	No connection

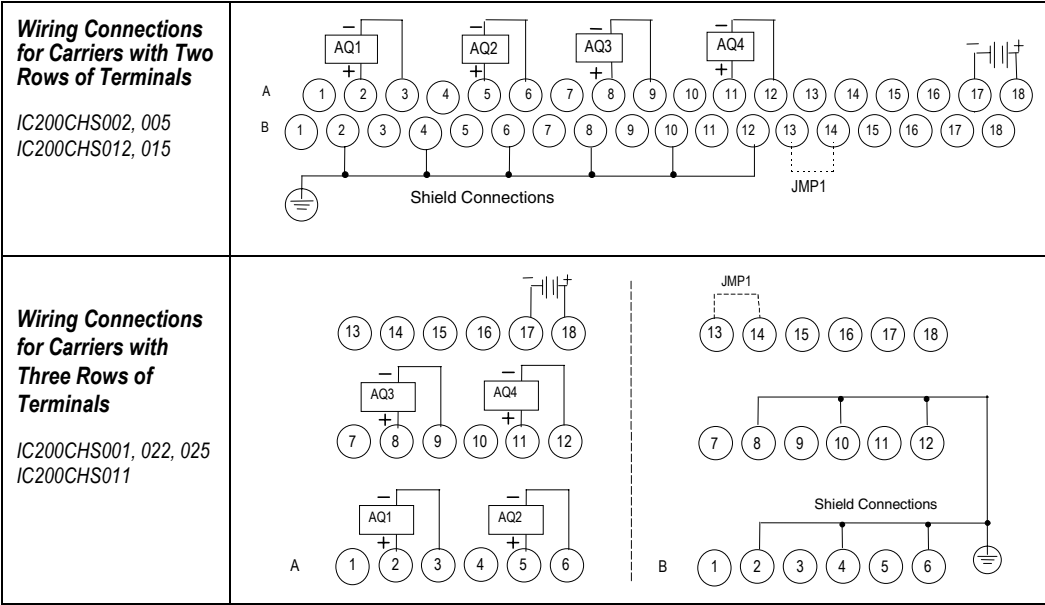

**IC200ALG321
Analog Output Module, 12 Bit Voltage 0 to 10VDC 4 Channels**

Jumper Selection

A jumper on the carrier can be used to select the output default mode.

If no jumper is installed on pins B13 and B14 outputs hold their last state (the last commanded value from the backplane) if backplane power or communications are interrupted or the PLC is stopped. With a jumper installed, if such conditions occur outputs default to 0 volts. This should only be changed with field power and backplane power removed.

Jumper	Selects
None	Hold Last State
JMP 1	Default to 0

Wiring Example

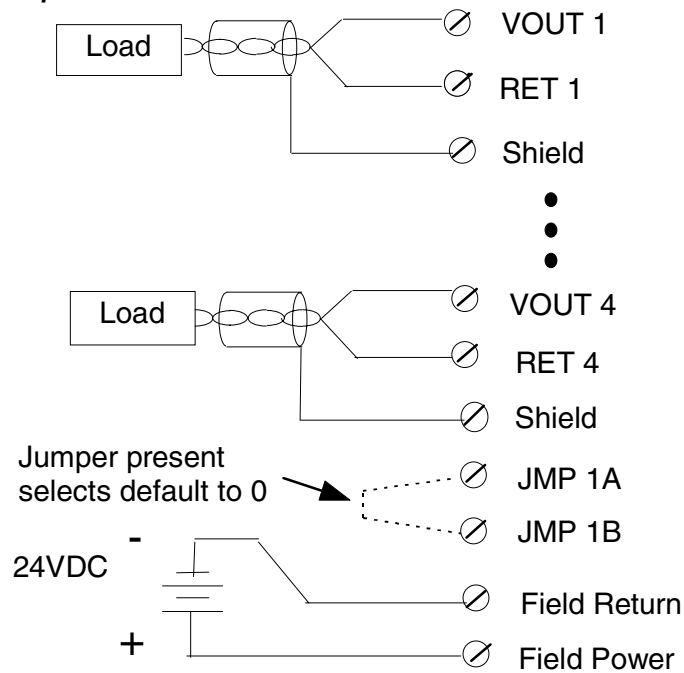

IC200ALG321
Analog Output Module, 12 Bit Voltage 0 to 10VDC 4 Channels

Cable Shield Connections

Shielded twisted pair cable is recommended for all of the analog channel connections. If the module is installed on a Terminal-style I/O Carrier (IC200CHS001, 002, or 005) or a Compact Terminal-style I/O Carrier (IC200CHS022, 025), the cable shield can be connected directly to the carrier per the Field Wiring Table. An Auxiliary I/O Terminal Strip (IC200TBM001, 002, or 005) can also be added to the Terminal-style I/O Carriers to aid in grounding shields. Be sure to ground the Auxiliary I/O Terminal Strip as well if you plan to use it for this purpose.

If the module is installed on a Connector-style I/O Carrier (IC200CHS003), the cable shield can be connected directly to an Interposing Terminal (IC200CHS011, 012, 015). Be sure to ground the Interposing Terminal. It is recommended to use a shielded interposing cable as well between the Interposing Terminal and the Connector Base. A custom shielded cable can be made using the Connector kit (IC200ACC302). In addition, a custom shield braid can be wrapped around standard Interposing Cables (IC200CBL105, 110, 120, 230). If this approach is used be sure to ground the braid.

All cable shield connections should be connected to earth ground and be kept as short as practical. The power cable does not need to be shielded.

IC200ALG321
Analog Output Module, 12 Bit Voltage 0 to 10VDC 4 Channels

Scaling

The graphs below show the relationship between the output voltage measured at the field terminals and the data that is output by the module.

Count vs Output Voltage

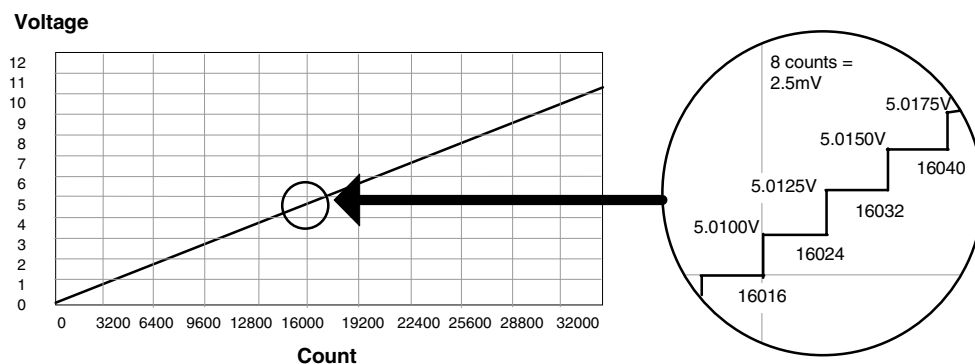

Voltage can be calculated using the following equation:

$$V_{out} = (\text{analog counts} \times 10.25) / 32768$$

The count value must be a multiple of 8. If the module receives a count value that is not a multiple of 8, it rounds the value down to the closest multiple of 8. For example:

Count	Voltage
16024	5.0125V
16030	5.0125V
16032	5.0150V

IC200ALG322

Analog Output Module, 12 Bit Voltage -10 to +10VDC 4 Channels

Analog output module IC200ALG322 provides four analog voltage outputs. The output range is -10 to +10VDC

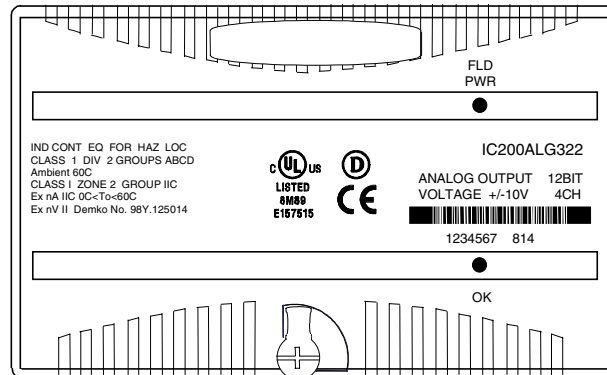

An external 24V power supply is required for the outputs.

Intelligent processing for this module is performed by the CPU or Network Interface Unit. The module receives 4 words of analog output data.

LED Indicators

The green FLD PWR LED indicates the presence of user-side power for the analog field-side circuits.

The green OK LED is on when backplane power is present to the module.

Diagnostics

The module reports a Loss of User Side Power fault for field-side circuits.

Configuration Parameters

The module is easily set up with a jumper for the outputs to either hold their last states or default to 0V if backplane power or communications are interrupted or the PLC is stopped. External user power must remain uninterrupted.

Outputs remain in their default or last state until the module receives different output data from the backplane, or until field power is removed.

IC200ALG322 Analog Output Module, 12 Bit Voltage -10 to +10VDC 4 Channels
--

Module Specifications

Module Characteristics	
Channels	4 single-ended, one group
Module ID	FFFF9040
Isolation:	
User input to logic (optical) and to frame ground	250VAC continuous; 1500VAC for 1 minute
Group to group	Not applicable
Channel to channel	None
LED indicators	FLD PWR LED indicates field power is present OK LED indicates backplane power is present
Backplane current consumption	5V output: 50mA maximum
Thermal derating	None
Configuration parameters	Output default
Diagnostics	Loss of User Side Power
External Power Supply	
Recommended range	+18 to +30VDC (including ripple)
Current consumption at recommended range	160mA max.(including load current)
12V operation range	9.6 to 15VDC, 12VDC nominal (including ripple)
Current consumption at 12V range	210mA max.(including load current)
Output Characteristics	
Output voltage	+/-10.24VDC
Load characteristics:	
Resistive	5000 Ohms minimum
Capacitive	1.0 μ F maximum
Accuracy at 25 degrees C**	+/- 0.3% typ. of full scale, +/- 0.5% max. of full scale
Accuracy at 0 to 60 degrees C	+/-1% maximum of full scale
Resolution	5mV = 16 counts
Update rate per module	0.3ms maximum
Channel-to-channel crosstalk rejection	70dB minimum
Output default	Hold Last State (default), 0 (configurable)

* In the presence of severe RF interference, (IEC 1000-4-3, 10V/m), accuracy may be degraded to +/-1%.

IC200ALG322

Analog Output Module, 12 Bit Voltage -10 to +10VDC 4 Channels

Field Wiring

Terminal	Connection	Terminal	Connection
A1	No connection	B1	No connection
A2	V OUT 1	B2	Shield Termination Point
A3	RET 1	B3	No connection
A4	No connection	B4	Shield Termination Point
A5	V OUT 2	B5	No connection
A6	RET 2	B6	Shield Termination Point
A7	No connection	B7	No connection
A8	V OUT 3	B8	Shield Termination Point
A9	RET 3	B9	No connection
A10	No connection	B10	Shield Termination Point
A11	V OUT 4	B11	No connection
A12	RET 4	B12	Shield Termination Point
A13	No connection	B13	JMP 1A
A14	No connection	B14	JMP 1B
A15	No connection	B15	No connection
A16	No connection	B16	No connection
A17	Field Return	B17	No connection
A18	Field Power	B18	No connection

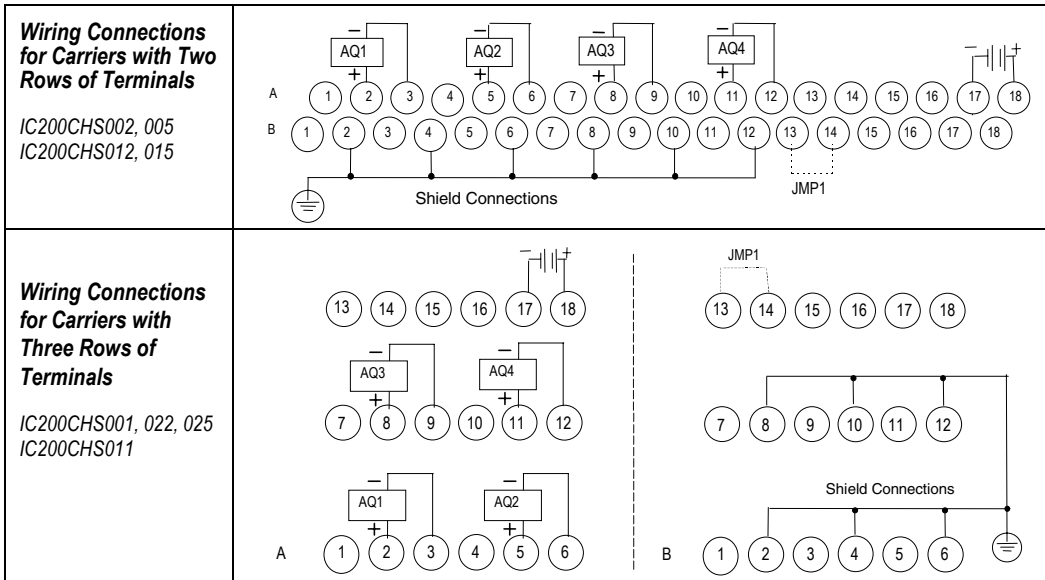

IC200ALG322
Analog Output Module, 12 Bit Voltage -10 to +10VDC 4 Channels

Jumper Selection

A jumper on the carrier can be used to select the output default mode.

If no jumper is installed on pins B13 and B14 outputs hold their last state (the last commanded value from the backplane) if backplane power or communications are interrupted or the PLC is stopped. With a jumper installed, if such conditions occur outputs default to 0 volts. This should only be changed with field power and backplane power removed.

Jumper	Selects
None	Hold Last State
JMP 1	Default to 0

Wiring Example

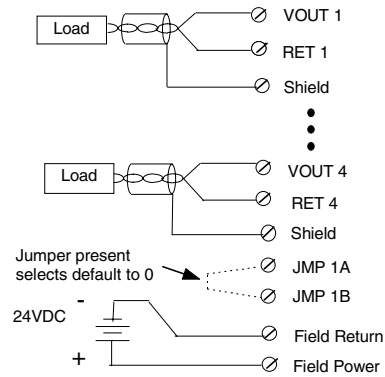

Cable Shield Connections

Shielded twisted pair cable is recommended for all of the analog channel connections. If the module is installed on a Terminal-style I/O Carrier (IC200CHS001, 002, or 005) or a Compact Terminal-style I/O Carrier (IC200CHS022, 025), the cable shield can be connected directly to the carrier per the Field Wiring Table. An Auxiliary I/O Terminal Strip (IC200TBM001, 002, or 005) can also be added to the Terminal-style I/O Carriers to aid in grounding shields. Be sure to ground the Auxiliary I/O Terminal Strip as well if you plan to use it for this purpose.

If the module is installed on a Connector-style I/O Carrier (IC200CHS003), the cable shield can be connected directly to an Interposing Terminal (IC200CHS011, 012, 015). Be sure to ground the Interposing Terminal. It is recommended to use a shielded interposing cable as well between the Interposing Terminal and the Connector Base. A custom shielded cable can be made using the Connector kit (IC200ACC302). In addition, a custom shield braid can be wrapped around standard Interposing Cables (IC200CBL105, 110, 120, 230). If this approach is used be sure to ground the braid.

All cable shield connections should be connected to earth ground and be kept as short as practical. The power cable does not need to be shielded.

IC200ALG322
Analog Output Module, 12 Bit Voltage -10 to +10VDC 4 Channels

Scaling

The graphs below show the relationship between the output voltage measured at the field terminals and the data that is output by the module.

Count vs Output Voltage

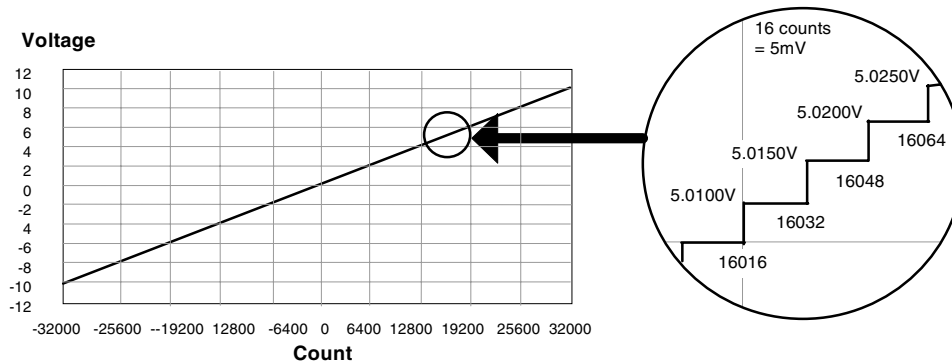

Voltage can be calculated using the following equation:

$$V_{out} = (\text{analog counts} \times 20.5) / 65535)$$

The count value must be a multiple of 16. If the module receives a count value that is not a multiple of 16, it rounds the value down to the closest multiple of 16. For example:

Count	Voltage
16032	5.0150V
16040	5.0150V
16048	5.0200V

IC200ALG325

Analog Output Module, 13 Bit Voltage 8 Channels

Analog output module IC200ALG325 provides eight analog voltage outputs. The output range can be either -10VDC to $+10\text{VDC}$ (bipolar) or 0V to $+10\text{VDC}$ (unipolar).

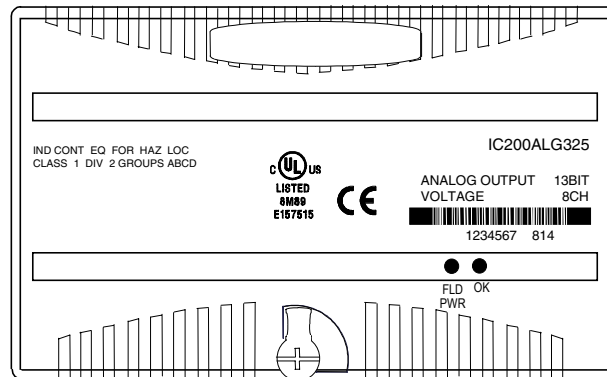

An external 24V power supply is required for the outputs.

Intelligent processing for this module is performed by the CPU or Network Interface Unit. The module receives 8 words of analog output data.

LED Indicators

The green FLD PWR LED indicates the presence of user-side power for the analog field-side circuits.

The green OK LED is on when backplane power is present to the module.

Diagnostics

The module reports a Loss of User Side Power fault for field-side circuits.

Configuration Parameters

The module has a default output range of -10VDC to $+10\text{VDC}$ (bipolar), but is easily set up with a jumper for the channels to output 0V to $+10\text{VDC}$ (unipolar).

The module is also easily set up with a jumper for the outputs to either hold their last states or default to 0V if backplane power or communications are interrupted or the PLC is stopped. External user power must remain uninterrupted.

Outputs remain in their default or last state until the module receives different output data from the backplane, or until field power is removed.

IC200ALG325
Analog Output Module, 13 Bit Voltage 8 Channels

Module Specifications

Module Characteristics	
Channels	8 single-ended, one group
Module ID	FFFF9080
Isolation:	
User input to logic (optical) and to frame ground	250VAC continuous; 1500VAC for 1 minute
Group to group	Not applicable
Channel to channel	None
LED indicators	FLD PWR LED indicates field power is present OK LED indicates backplane power is present
Backplane current consumption	5V output: 50 mA maximum
External power supply:	
Range	+18 to +30VDC (including ripple)
Current consumption	102mA maximum
Thermal derating	None
Configuration parameters	Range, output default
Diagnostics	Loss of User Side Power
Output Characteristics	
Output voltage	-10.24 to +10.24VDC (bipolar range) 0 to +10.24VDC (unipolar range)
Load characteristics:	
Resistive	5000 Ohms minimum
Capacitive	1.0 μ F maximum
Accuracy at:	
25 degrees C	+/- 0.3% typical of full scale, +/- 0.5% maximum of full scale
0 to 60 degrees C	+/-1% maximum of full scale
Resolution	1.25mV = 4 counts
Update rate per module	10 mSec maximum
Channel-to-channel crosstalk rejection	70dB minimum
Output default	Hold Last State (default) 0V (configurable)

IC200ALG325
Analog Output Module, 13 Bit Voltage 8 Channels

Field Wiring

Terminal	Connection	Terminal	Connection
A1	Shield Termination Point	B1	JMP 1 (Range)
A2	V OUT 5	B2	Jumper (1-2) RTN
A3	RET (5-6)	B3	JMP 2 (Hold)
A4	V OUT 6	B4	Shield Termination Point
A5	Shield Termination Point	B5	V OUT 1
A6	V OUT 7	B6	RTN (1-2)
A7	RTN (7-8)	B7	V OUT 2
A8	V OUT 8	B8	Shield Termination Point
A9	Shield Termination Point	B9	V OUT 3
A10	No connection	B10	RTN (3-4)
A11	No connection	B11	V OUT 4
A12	No connection	B12	Shield Termination Point
A13	No connection	B13	Shield Termination Point
A14	No connection	B14	No connection
A15	No connection	B15	No connection
A16	No connection	B16	No connection
A17	Shield Termination Point	B17	Field Return
A18	Shield Termination Point	B18	Field Power

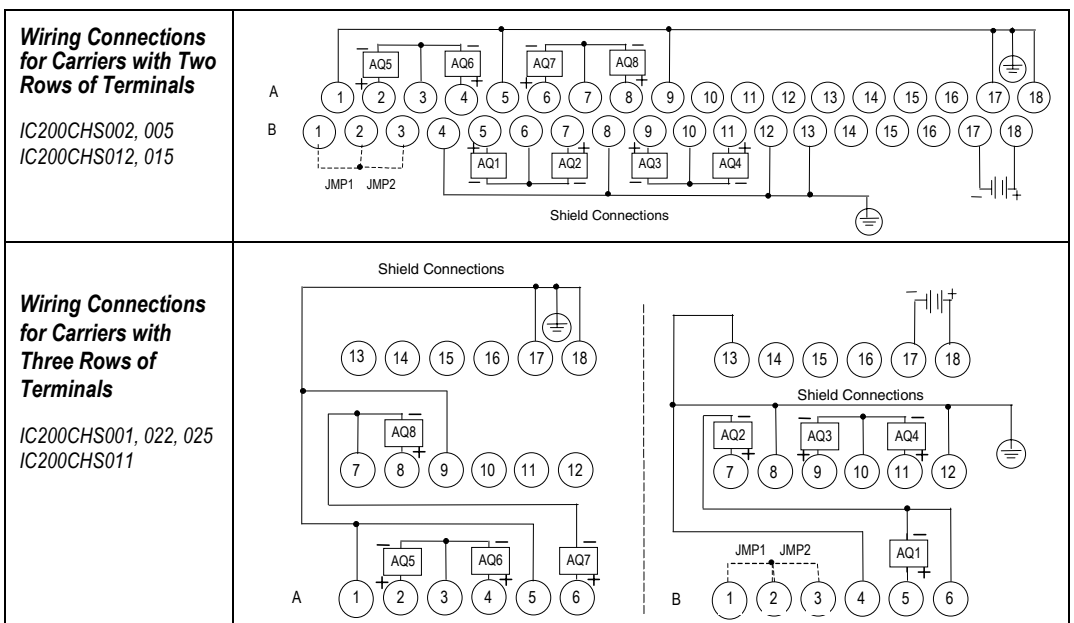

IC200ALG325
Analog Output Module, 13 Bit Voltage 8 Channels

Jumper Selection

Jumpers on the carrier can be used to select the output range and output default mode.

Range Jumper

If no jumper is installed on pins B1 and B2, outputs are configured for the bipolar range of -10V to +10V. With a jumper installed, the outputs are configured for the unipolar range of 0V to +10V.

Range Jumper (JMP 1)	Range
None	-10V to +10V
Installed	0V to +10V

Hold Jumper

If no jumper is installed on pins B2 and B3, outputs hold their last state (the last commanded value from the backplane) if backplane power or communications are interrupted or the PLC is stopped. With a jumper installed, outputs default to 0V. This should only be changed with the field power and backplane power removed.

Hold Jumper (JMP 2)	Output Default
None	Hold Last State
Installed	0V

Wiring Example

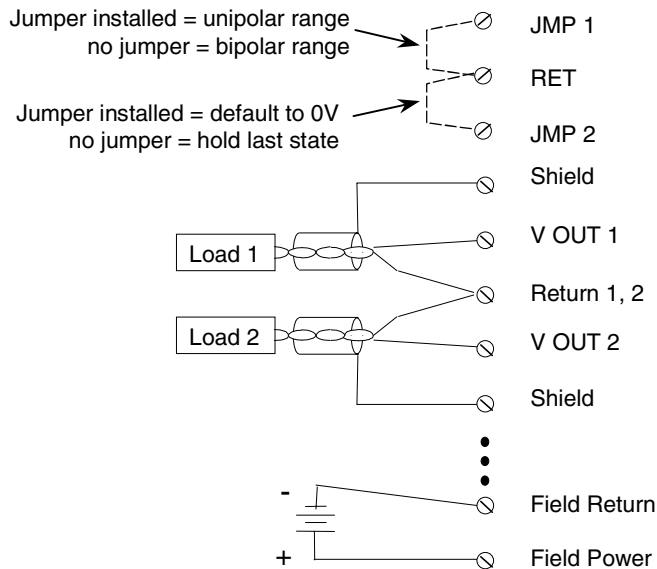

IC200ALG325
Analog Output Module, 13 Bit Voltage 8 Channels

Cable Shield Connections

Shielded twisted pair cable is recommended for all of the analog channel connections. If the module is installed on a Terminal-style I/O Carrier (IC200CHS001, 002, or 005) or a Compact Terminal-style I/O Carrier (IC200CHS022, 025), the cable shield can be connected directly to the carrier per the Field Wiring Table. An Auxiliary I/O Terminal Strip (IC200TBM001, 002, or 005) can also be added to the Terminal-style I/O Carriers to aid in grounding shields. Be sure to ground the Auxiliary I/O Terminal Strip as well if you plan to use it for this purpose.

If the module is installed on a Connector-style I/O Carrier (IC200CHS003), the cable shield can be connected directly to an Interposing Terminal (IC200CHS011, 012, 015). Be sure to ground the Interposing Terminal. It is recommended to use a shielded interposing cable as well between the Interposing Terminal and the Connector Base. A custom shielded cable can be made using the Connector kit (IC200ACC302). In addition, a custom shield braid can be wrapped around standard Interposing Cables (IC200CBL105, 110, 120, 230). If this approach is used be sure to ground the braid.

All cable shield connections should be connected to earth ground and be kept as short as practical. The power cable does not need to be shielded.

IC200ALG325
Analog Output Module, 13 Bit Voltage 8 Channels

Scaling for Unipolar Outputs

The graph below shows the relationship between the output voltage measured at the field terminals and the data that is output by the module, when outputs are set up for the unipolar range.

Count vs Output Voltage, Unipolar

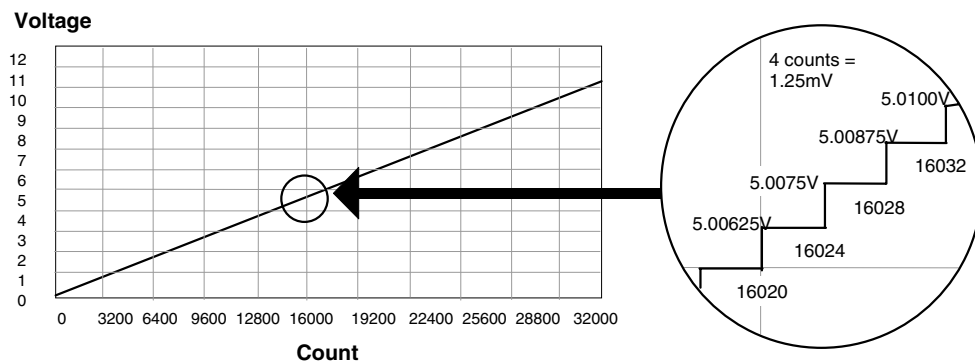

Voltage can be calculated using the following equation:

$$V_{out} = (\text{analog counts} \times 10.24) / 32768)$$

The count value must be a multiple of 4. If the module receives a count value that is not a multiple of 4, it rounds the value down to the closest multiple of 4. For example:

Count	Voltage
16024	5.0075V
16026	5.0075V
16028	5.00875V

IC200ALG325
Analog Output Module, 13 Bit Voltage 8 Channels

Scaling for Bipolar Outputs

The graph below shows the relationship between the output voltage measured at the field terminals and the data that is output by the module, when outputs are set up for the **bipolar** range.

Count vs Output Voltage, Bipolar

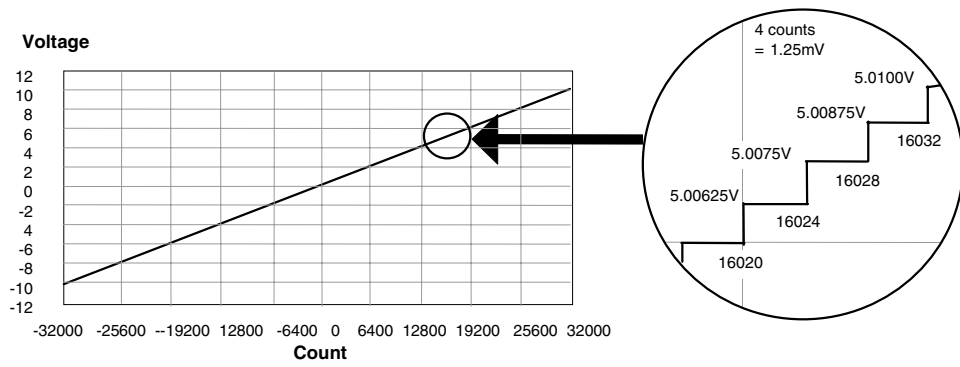

Voltage can be calculated using the following equation:

$$V_{out} = (\text{analog counts} \times 20.48) / 65536$$

The count value must be a multiple of 4. If the module receives a count value that is not a multiple of 4, it rounds the value down to the closest multiple of 4. For example:

Count	Voltage
16024	5.0075V
16026	5.0075V
16028	5.00875V

IC200ALG326 **Analog Output Module, 13 Bit Current, 8 Channels**

Analog output module IC200ALG326 provides eight 4mA to 20mA analog current-sourcing outputs. Including a modest amount of overrange current, approximately 20.38mA of output current per channel is available to drive output loads.

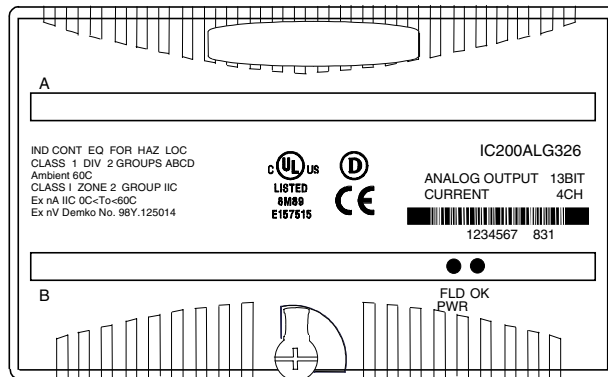

An external source of DC power is required for the outputs.

Intelligent processing for this module is performed by the CPU or NIU. The module receives 8 words of analog output data.

LED Indicators

The green FLD PWR LED indicates the presence of user-side power for the analog field-side circuits.

The green OK LED is on when backplane power is present to the module.

Diagnostics

The module reports a Loss of User Side Power fault for field-side circuits.

Configuration Parameters

The module can be configured for either the 4-20 mA or 0-20 mA output current range by installing a jumper wire on the field terminals.

The module can also be easily set up with a jumper for the outputs to either hold their last states or default to low end of range if backplane power or communications are interrupted or the PLC is stopped. External user power must remain uninterrupted.

Outputs remain in their default or last state until the module receives different output data from the backplane, or until field power is removed.

IC200ALG326
Analog Output Module, 13 Bit Current, 8 Channels

Module Specifications

Module Characteristics	
Channels	8 single-ended, one group
Module ID	FFFF9480
Isolation:	
User input to logic and to frame ground	250VAC continuous; 1500VAC for 1 minute
Group to group	Not applicable
Channel to channel	None
LED indicators	FLD PWR LED indicates field power is present OK LED indicates backplane power is present
Backplane current consumption	5V output: 50mA maximum
External power supply:	
Range	+18 to +30VDC (including ripple)
Current consumption	2A inrush maximum 100 mA maximum (no load) 185 mA maximum (all 8 outputs at full scale)
Thermal derating	None
Configuration parameter	Range, output default
Diagnostics	Loss of User Side (Field) Power
Output Characteristics	
Output current	4 to 20mA (default) 0 to 20mA (configured with jumper)
Load characteristics:	
Resistive	0 to 800 Ohms maximum*
Capacitive	0.1μF maximum
Inductive	0.5H maximum
Accuracy:	
+25 deg C**	+/- 0.3% of full scale (typical), +/- 0.5% of full scale (max)
0 to +60 degrees C	+/-1% of full scale (max)
Resolution	4-20 mA: 5 counts = 2.5 uA (~12.7 bits) 0-20 mA: 4 counts = 2.5 uA (13 bits)
Update rate per module	15 mSec maximum
Channel-to-channel crosstalk rejection	70dB minimum
Output default	Hold Last State (default) Low End of Range (configurable)

* $R_{L(MAX)} = (V_{FIELD\ PS} - 4V) / 20.38mA$

** In the presence of severe RF interference, (IEC 1000-4-3, 10V/m), accuracy may be degraded an additional +/-1%.

IC200ALG326
Analog Output Module, 13 Bit Current, 8 Channels

Field Wiring

Terminal	Connection	Terminal	Connection
A1	Shield Termination Point	B1	Range Jumper
A2	I OUT 5	B2	Jumper RET
A3	RET	B3	Hold Jumper
A4	I OUT 6	B4	Shield Termination Point
A5	Shield Termination Point	B5	I OUT 1
A6	I OUT 7	B6	RET
A7	RET	B7	I OUT 2
A8	I OUT 8	B8	Shield Termination Point
A9	Shield Termination Point	B9	I OUT 3
A10	No connection	B10	RET
A11	No connection	B11	I OUT 4
A12	No connection	B12	Shield Termination Point
A13	No connection	B13	Shield Termination Point
A14	No connection	B14	No connection
A15	No connection	B15	No connection
A16	No connection	B16	No connection
A17	Shield Termination Point	B17	DC-
A18	Shield Termination Point	B18	DC+

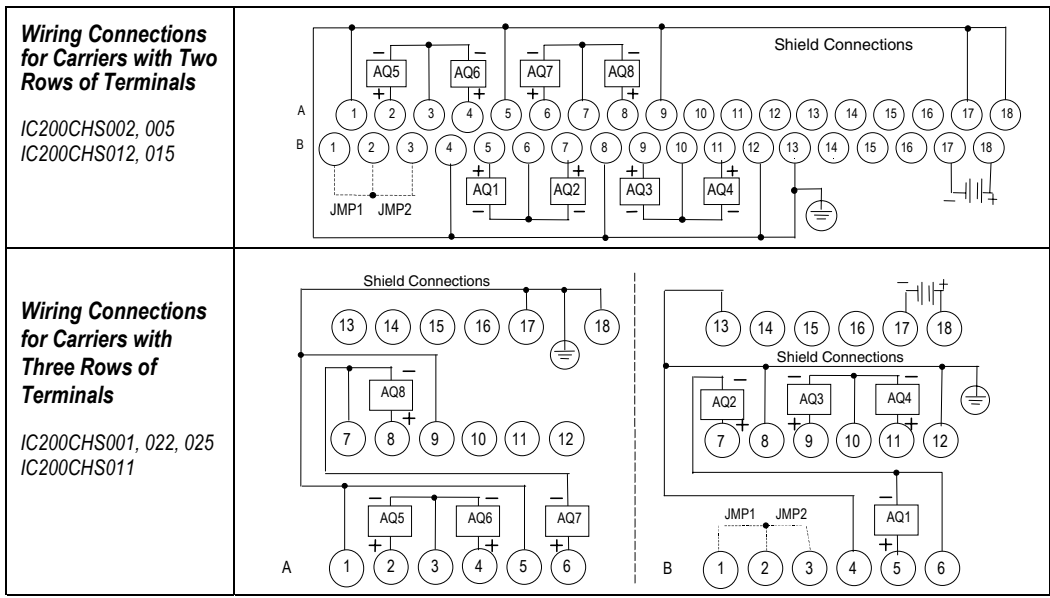

IC200ALG326

Analog Output Module, 13 Bit Current, 8 Channels

Jumper Selection

Range Jumper

If no jumper is installed the output current range will be 4 to 20 mA. With a jumper installed the output current range is 0 to 20 mA. This should only be changed with field power and backplane power removed. The corresponding parameter in the hardware configuration must also be adjusted accordingly.

Range Jumper	Default
None	4 to 20 mA
JMP 1	0 to 20 mA

Hold Jumper

If no jumper is installed outputs hold their last state (the last commanded value from the backplane) if backplane power or communications are interrupted or the PLC is stopped. With a jumper installed, if such conditions occur outputs default to 0/4mA. This should only be changed with field power and backplane power removed. The corresponding parameter in the hardware configuration must be adjusted accordingly.

Hold Jumper	Default
None	Hold Last State
JMP 2	0/4mA

The “Default Low End of Range” value can be either 4mA or 0mA. The default depends on the PLC status, output current range selected, and whether the module is controlled by a VersaMax PLC CPU or a Network Interface Unit (NIU) module. In some cases, the module will output 0mA instead of 4mA, even when configured for the 4-20mA range as shown in the following chart.

Action	Module Set to Default Low End of Range (Default)				Module Set to Hold Last State (HLS)			
	Module in NIU Rack		Module in CPU Rack		Module in NIU Rack		Module in CPU Rack	
	0-20mA	4-20mA	0-20mA	4-20mA	0-20mA	4-20mA	0-20mA	4-20mA
Run to Stop	0mA	4mA	0mA	0mA	HLS	HLS	HLS	HLS
Loss of Field Power	0mA	0mA	0mA	0mA	0mA	0mA	0mA	0mA
Loss of Backplane Power	0mA	0mA	0mA	0mA	HLS	HLS	HLS	HLS
Loss of Communication	0mA	4mA	N/A	N/A	HLS	HLS	N/A	N/A
Loss of Module	0mA	0mA	0mA	0mA	0mA	0mA	0mA	0mA
Loss of CPU/NIU Power	0mA	0mA	0mA	0mA	HLS	HLS	HLS	HLS

IC200ALG326 Analog Output Module, 13 Bit Current, 8 Channels

Wiring Example

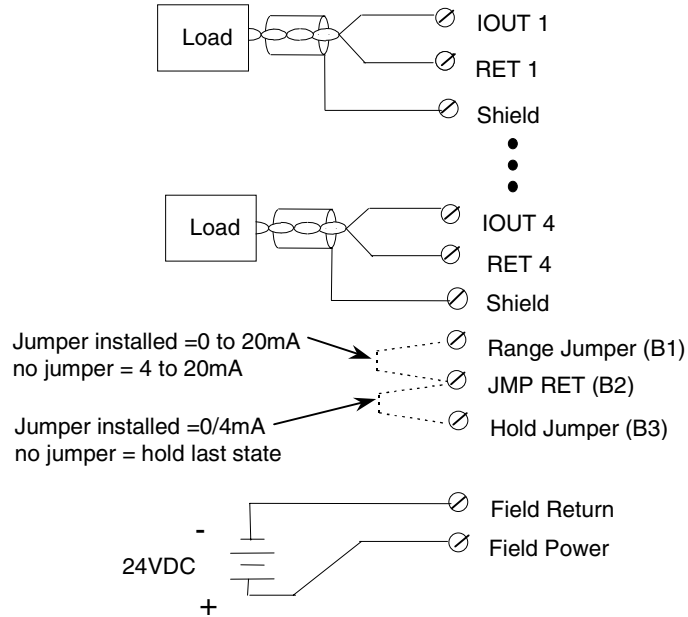

Cable Shield Connections

Shielded twisted pair cable is recommended for all of the analog channel connections. If the module is installed on a Terminal-style I/O Carrier (IC200CHS001, 002, or 005) or a Compact Terminal-style I/O Carrier (IC200CHS022, 025), the cable shield can be connected directly to the carrier per the Field Wiring Table. An Auxiliary I/O Terminal Strip (IC200TBM001, 002, or 005) can also be added to the Terminal-style I/O Carriers to aid in grounding shields. Be sure to ground the Auxiliary I/O Terminal Strip as well if you plan to use it for this purpose.

If the module is installed on a Connector-style I/O Carrier (IC200CHS003), the cable shield can be connected directly to an Interposing Terminal (IC200CHS011, 012, 015). Be sure to ground the Interposing Terminal. It is recommended to use a shielded interposing cable as well between the Interposing Terminal and the Connector Base. A custom shielded cable can be made using the Connector kit (IC200ACC302). In addition, a custom shield braid can be wrapped around standard Interposing Cables (IC200CBL105, 110, 120, 230). If this approach is used be sure to ground the braid.

All cable shield connections should be connected to earth ground and be kept as short as practical. The power cable does not need to be shielded.

IC200ALG326
Analog Output Module, 13 Bit Current, 8 Channels

Output Current Range Scaling / Step Change

In 0-20mA range mode, a current output signal value of 0mA corresponds to a %AQ value of 0 counts, and 20mA corresponds to a %AQ value of +32,000 counts. In 4-20mA range mode, a value of 0 %AQ counts corresponds to an output current of 4mA and a value of +32,000 %AQ counts corresponds to an output current of 20mA. If the module is installed in a Versamax PLC, it converts negative value commands to 0 mA regardless of range selected. If the module is controlled by a Network Interface Unit (NIU), it converts any negative value commands to the low end of range.

The illustration below shows the relationship between output signal strength and commanded %AQ counts. It depicts the step change in output current level for various command values. Not every command value results in a change in the output current level due to the module's resolution.

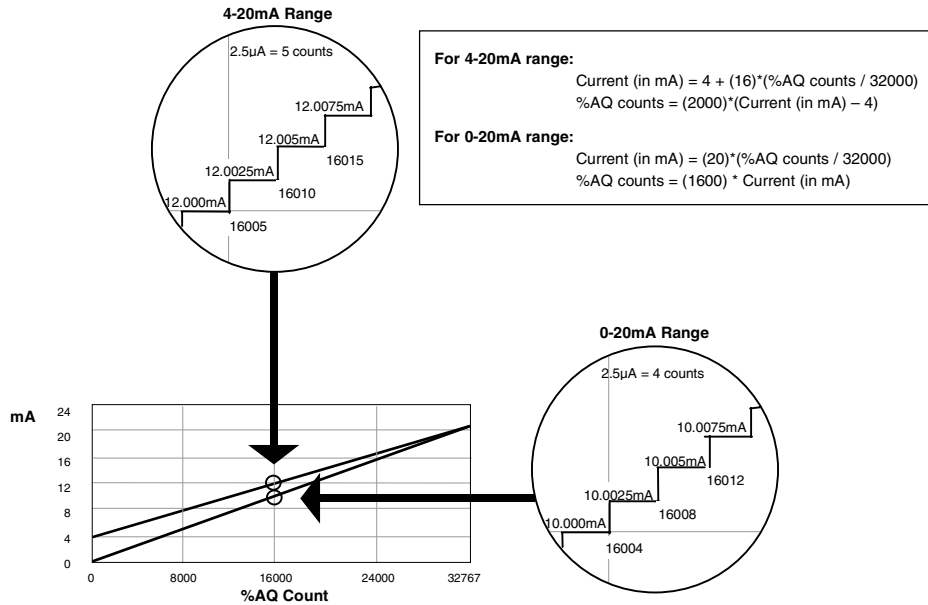

4-20 mA Range Step Change Example

Count	Current
16000	12.0000 mA
16005	12.0025 mA
16008	12.0025 mA
16009	12.0025 mA
16010	12.0050 mA

IC200ALG327 Analog Output Module, 13 Bit Voltage 12 Channels

Analog output module IC200ALG327 provides twelve analog voltage outputs. The output range can be either -10VDC to $+10\text{VDC}$ (bipolar) or 0V to $+10\text{VDC}$ (unipolar).

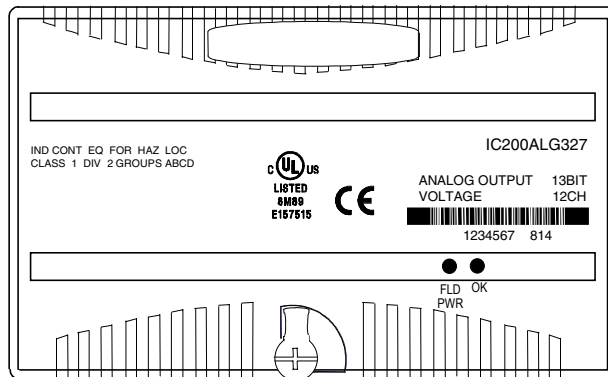

An external 24V power supply is required for the outputs.

Intelligent processing for this module is performed by the CPU or Network Interface Unit. The module receives 12 words of analog output data.

LED Indicators

The green FLD PWR LED indicates the presence of user-side power for the analog field-side circuits.

The green OK LED is on when backplane power is present to the module.

Diagnostics

The module reports a Loss of User Side Power fault for field-side circuits.

Configuration Parameters

The module has a default output range of -10VDC to $+10\text{VDC}$ (bipolar), but is easily set up with a jumper for the channels to output 0V to $+10\text{VDC}$ (unipolar).

The module is also easily set up with a jumper for the outputs to either hold their last states or default to 0V if backplane power or communications are interrupted or the PLC is stopped. External user power must remain uninterrupted.

Outputs remain in their default or last state until the module receives different output data from the backplane, or until field power is removed.

IC200ALG327
Analog Output Module, 13 Bit Voltage 12 Channels

Module Specifications

Module Characteristics	
Channels	12 single-ended, one group
Module ID	FFFF90C0
Isolation:	
User input to logic (optical) and to frame ground	250VAC continuous; 1500VAC for 1 minute
Group to group	Not applicable
Channel to channel	None
LED indicators	FLD PWR LED indicates field power is present OK LED indicates backplane power is present
Backplane current consumption	5V output: 50mA maximum
External power supply:	
Range	+18 to +30VDC (including ripple)
Current consumption	112mA maximum
Thermal derating	None
Configuration parameters	Range, output default
Diagnostics	Loss of User Side Power
Output Characteristics	
Output voltage	-10.24 to +10.24VDC (bipolar range) 0 to +10.24VDC (unipolar range)
Load characteristics:	
Resistive	5000 Ohms minimum
Capacitive	1.0 μ F maximum
Accuracy:	
at 25 degrees C	+/- 0.3% typical of full scale, +/- 0.5% maximum of full scale
0 to 60 degrees C	+/-1% maximum of full scale
Resolution	1.25mV = 4 counts
Update rate per module	15 mSec maximum
Channel-to-channel crosstalk rejection	70dB minimum
Output default	Hold Last State (default) 0V (configurable)

IC200ALG327
Analog Output Module, 13 Bit Voltage 12 Channels

Field Wiring

Terminal	Connection	Terminal	Connection
A1	Shield Termination Point	B1	JMP 1 (Range)
A2	V OUT 5	B2	Jumper (1-2) RTN
A3	RET (5-6)	B3	JMP 2 (Hold)
A4	V OUT 6	B4	Shield Termination Point
A5	Shield Termination Point	B5	V OUT 1
A6	V OUT 7	B6	RTN (1-2)
A7	RTN (7-8)	B7	V OUT 2
A8	V OUT 8	B8	Shield Termination Point
A9	Shield Termination Point	B9	V OUT 3
A10	V OUT 9	B10	RTN (3-4)
A11	RTN (9-10)	B11	V OUT 4
A12	V OUT 10	B12	Shield Termination Point
A13	Shield Termination Point	B13	Shield Termination Point
A14	V OUT 11	B14	No connection
A15	RTN (11-12)	B15	No connection
A16	V OUT 12	B16	No connection
A17	Shield Termination Point	B17	Field Return
A18	Shield Termination Point	B18	Field Power

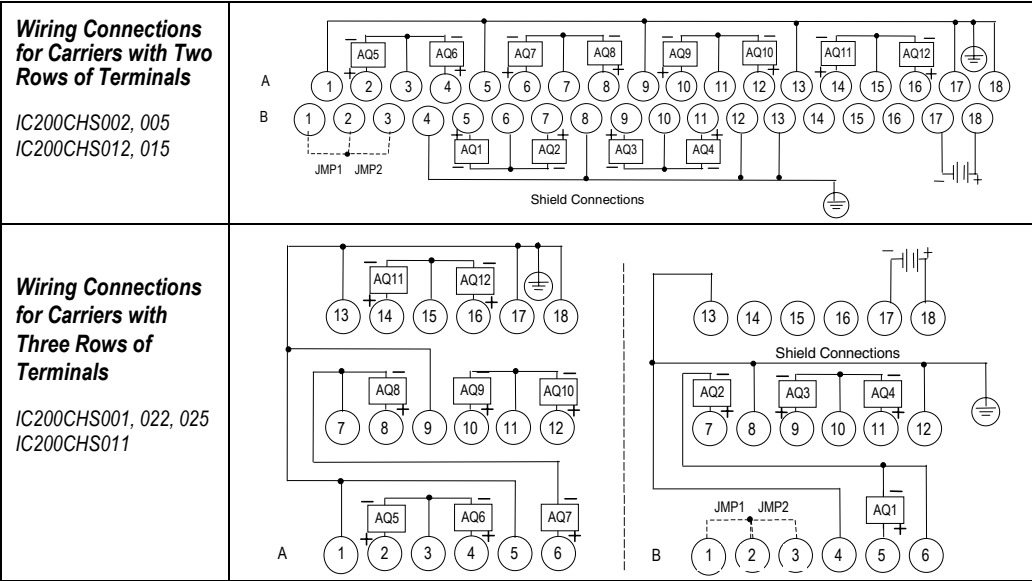

IC200ALG327

Analog Output Module, 13 Bit Voltage 12 Channels

Jumper Selection

Jumpers on the carrier can be used to select the output range and output default mode.

Range Jumper

If no jumper is installed on pins B1 and B2, outputs are configured for the bipolar range of -10V to +10V. With a jumper installed, the outputs are configured for the unipolar range of 0V to +10V.

Range Jumper (JMP 1)	Range
None	-10V to +10V
Installed	0V to +10V

Hold Jumper

If no jumper is installed on pins B2 and B3, outputs hold their last state (the last commanded value from the backplane) if backplane power or communications are interrupted or the PLC is stopped. With a jumper installed, outputs default to 0V. This should only be changed with the field power and backplane power removed.

Hold Jumper (JMP 2)	Output Default
None	Hold Last State
Installed	0V

Wiring Example

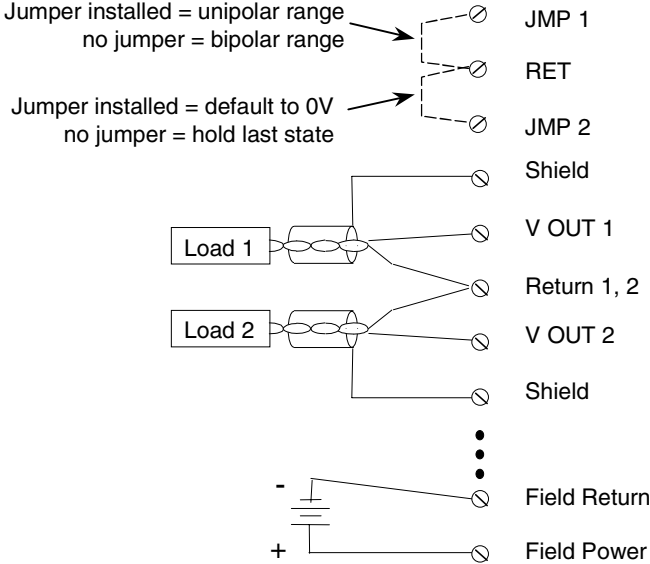

IC200ALG327
Analog Output Module, 13 Bit Voltage 12 Channels**Cable Shield Connections**

Shielded twisted pair cable is recommended for all of the analog channel connections. If the module is installed on a Terminal-style I/O Carrier (IC200CHS001, 002, or 005) or a Compact Terminal-style I/O Carrier (IC200CHS022, 025), the cable shield can be connected directly to the carrier per the Field Wiring Table. An Auxiliary I/O Terminal Strip (IC200TBM001, 002, or 005) can also be added to the Terminal-style I/O Carriers to aid in grounding shields. Be sure to ground the Auxiliary I/O Terminal Strip as well if you plan to use it for this purpose.

If the module is installed on a Connector-style I/O Carrier (IC200CHS003), the cable shield can be connected directly to an Interposing Terminal (IC200CHS011, 012, 015). Be sure to ground the Interposing Terminal. It is recommended to use a shielded interposing cable as well between the Interposing Terminal and the Connector Base. A custom shielded cable can be made using the Connector kit (IC200ACC302). In addition, a custom shield braid can be wrapped around standard Interposing Cables (IC200CBL105, 110, 120, 230). If this approach is used be sure to ground the braid.

All cable shield connections should be connected to earth ground and be kept as short as practical. The power cable does not need to be shielded.

IC200ALG327
Analog Output Module, 13 Bit Voltage 12 Channels

Scaling for Unipolar Outputs

The graph below shows the relationship between the output voltage measured at the field terminals and the data that is output by the module, when outputs are set up for the **unipolar range**.

Count vs Output Voltage, Unipolar

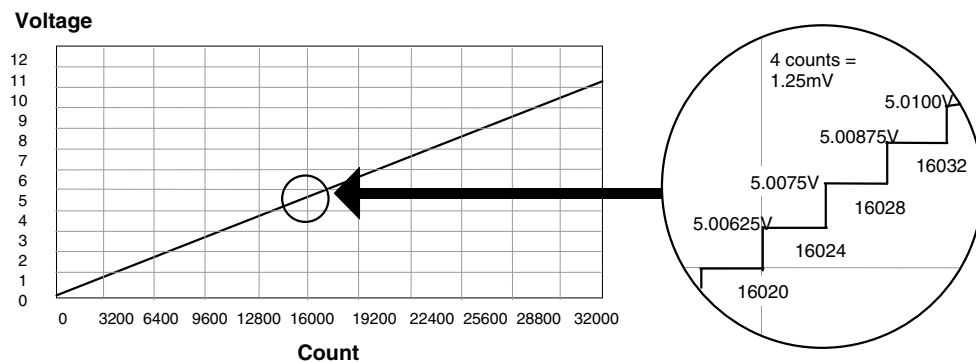

Voltage can be calculated using the following equation:

$$V_{out} = (\text{analog counts} \times 10.24) / 32768)$$

The count value must be a multiple of 4. If the module receives a count value that is not a multiple of 4, it rounds the value down to the closest multiple of 4. For example:

Count	Voltage
16024	5.0075V
16026	5.0075V
16028	5.00875V

IC200ALG327
Analog Output Module, 13 Bit Voltage 12 Channels

Scaling for Bipolar Outputs

The graph below shows the relationship between the output voltage measured at the field terminals and the data that is output by the module, when outputs are set up for the **bipolar** range.

Count vs Output Voltage, Bipolar

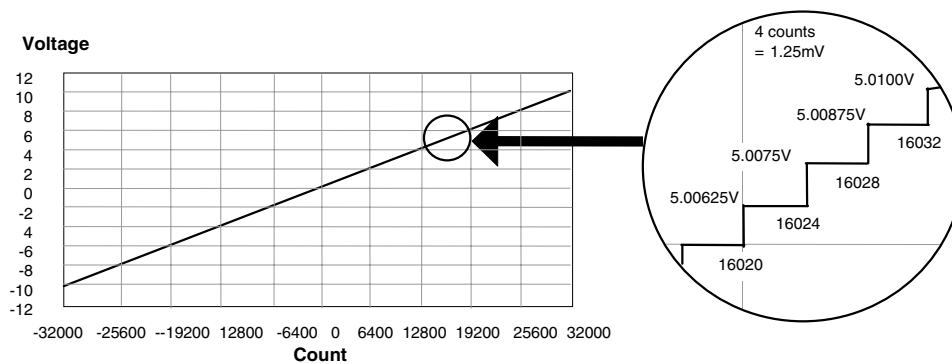

Voltage can be calculated using the following equation:

$$V_{out} = (\text{analog counts} \times 20.48) / 65536$$

The count value must be a multiple of 4. If the module receives a count value that is not a multiple of 4, it rounds the value down to the closest multiple of 4. For example:

Count	Voltage
16024	5.0075V
16026	5.0075V
16028	5.00875V

IC200ALG328

Analog Output Module, 13 Bit Current, 12 Channels

Analog output module IC200ALG328 provides twelve 4mA to 20mA analog current-sourcing outputs. Including a modest amount of overrange current, approximately 20.38mA of output current per channel is available to drive output loads.

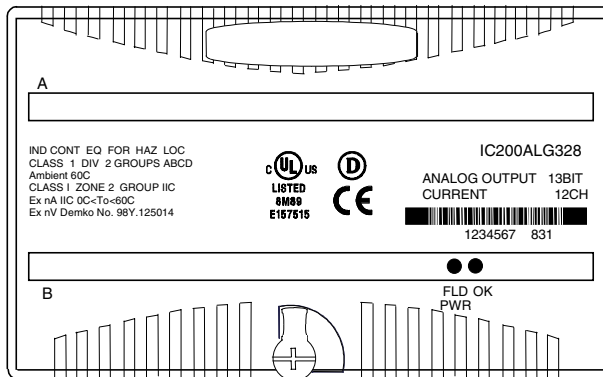

An external source of DC power is required for the outputs.

Intelligent processing for this module is performed by the CPU or NIU. The module receives 12 words of analog output data.

LED Indicators

The green FLD PWR LED indicates the presence of user-side power for the analog field-side circuits.

The green OK LED is on when backplane power is present to the module.

Diagnostics

The module reports a Loss of User Side Power fault for field-side circuits.

Configuration Parameters

The module can be configured for either the 4-20 mA or 0-20 mA output current range by installing a jumper wire on the field terminal strip.

The module can also be easily set up with a jumper for the outputs to either hold their last states or default to the low end of their range if backplane power or communications are interrupted or the PLC is stopped. External user power must remain uninterrupted.

Outputs remain in their default or last state until the module receives different output data from the backplane, or until field power is removed.

IC200ALG328
Analog Output Module, 13 Bit Current, 12 Channels

Module Specifications

Module Characteristics	
Channels	12 single-ended, one group
Module ID	FFFF94C0
Isolation:	
User input to logic and to frame ground	250VAC continuous; 1500VAC for 1 minute
Group to group	Not applicable
Channel to channel	None
LED indicators	FLD PWR LED indicates field power is present OK LED indicates backplane power is present
Backplane current consumption	5V output: 50mA maximum
External power supply:	
Range	+18 to +30VDC (including ripple)
Current consumption	2A inrush maximum 100 mA maximum (no load) 270 mA maximum (all 12 outputs at full scale)
Thermal derating	See diagram
Configuration parameter	Range, output default
Diagnostics	Loss of User Side (Field) Power
Output Characteristics	
Output current	4 to 20mA (default) 0 to 20mA (configured with jumper)
Load characteristics:	
Resistive	0 to 800 Ohms maximum*
Capacitive	0.1µF maximum
Inductive	0.5H maximum
Accuracy:	
+25 deg C**	+/- 0.3% of full scale (typical), +/- 0.5% of full scale (max.)
0 to +60 degrees C	+/-1% of full scale (max.)
Resolution	4-20 mA: 5 counts = 2.5 uA (~12.7 bits) 0-20 mA: 4 counts = 2.5 uA (13 bits)
Update rate per module	15 mSec maximum
Channel-to-channel crosstalk rejection	70dB minimum
Output default	Hold Last State (default) Low End of Range(configurable)

* $R_{L(MAX)} = (V_{FIELD PS} - 4V) / 20.38mA$

** In the presence of severe RF interference, (IEC 1000-4-3, 10V/m), accuracy may be degraded an additional +/-1%.

IC200ALG328
Analog Output Module, 13 Bit Current, 12 Channels

Field Wiring

Terminal	Connection	Terminal	Connection
A1	Shield Termination Point	B1	Range Jumper
A2	I OUT 5	B2	Jumper RET
A3	RET	B3	Hold Jumper
A4	I OUT 6	B4	Shield Termination Point
A5	Shield Termination Point	B5	I OUT 1
A6	I OUT 7	B6	RET
A7	RET	B7	I OUT 2
A8	I OUT 8	B8	Shield Termination Point
A9	Shield Termination Point	B9	I OUT 3
A10	I OUT 9	B10	RET
A11	RET	B11	I OUT 4
A12	I OUT 10	B12	Shield Termination Point
A13	Shield Termination Point	B13	Shield Termination Point
A14	I OUT 11	B14	No connection
A15	RET	B15	No connection
A16	I OUT 12	B16	No connection
A17	Shield Termination Point	B17	DC-
A18	Shield Termination Point	B18	DC+

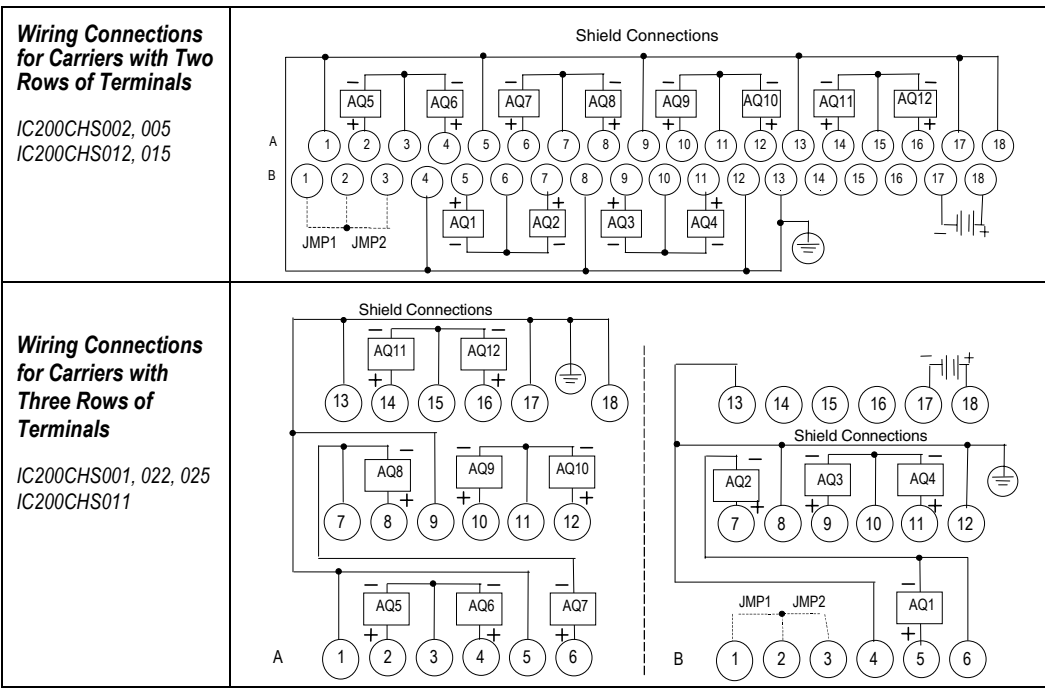

IC200ALG328
Analog Output Module, 13 Bit Current, 12 Channels

Jumper Selection

Range Jumper

If no jumper is installed the output current range will be 4 to 20 mA. With a jumper installed the output current range is 0 to 20 mA. This should only be changed with field power and backplane power removed. The corresponding parameter in the hardware configuration must also be adjusted accordingly.

Range Jumper	Default
None	4 to 20 mA
JMP 1	0 to 20 mA

Hold Jumper

If no jumper is installed outputs hold their last states (the last commanded values from the backplane) if backplane power or communications are interrupted or the PLC is stopped. With a jumper installed, if such conditions occur outputs default to 0/4mA. This should only be changed with field power and backplane power removed. The corresponding parameter in the hardware configuration must also be adjusted accordingly.

Hold Jumper	Default
None	Hold Last State
JMP 2	0/4mA

The “Default Low End of Range” value can be either 4mA or 0mA. The default depends on the PLC status, output current range selected, and whether the module is controlled by a VersaMax PLC CPU or a Network Interface Unit (NIU) module. In some cases, the module will output 0mA instead of 4mA, even when configured for the 4-20mA range as shown in the following chart.

Action	Module Set to Default Low End of Range (Default)				Module Set to Hold Last State (HLS)			
	Module in NIU Rack		Module in CPU Rack		Module in NIU Rack		Module in CPU Rack	
	0-20mA	0-20mA	4-20mA	0-20mA	4-20mA	4-20mA	0-20mA	4-20mA
Run to Stop	0mA	0mA	4mA	0mA	HLS	HLS	HLS	HLS
Loss of Field Power	0mA	0mA	0mA	0mA	0mA	0mA	0mA	0mA
Loss of Backplane Power	0mA	0mA	0mA	0mA	HLS	HLS	HLS	HLS
Loss of Communication	0mA	0mA	4mA	N/A	HLS	HLS	N/A	N/A
Loss of Module	0mA	0mA	0mA	0mA	0mA	0mA	0mA	0mA
Loss of CPU/NIU Power	0mA	0mA	0mA	0mA	HLS	HLS	HLS	HLS

IC200ALG328

Analog Output Module, 13 Bit Current, 12 Channels

Wiring Example

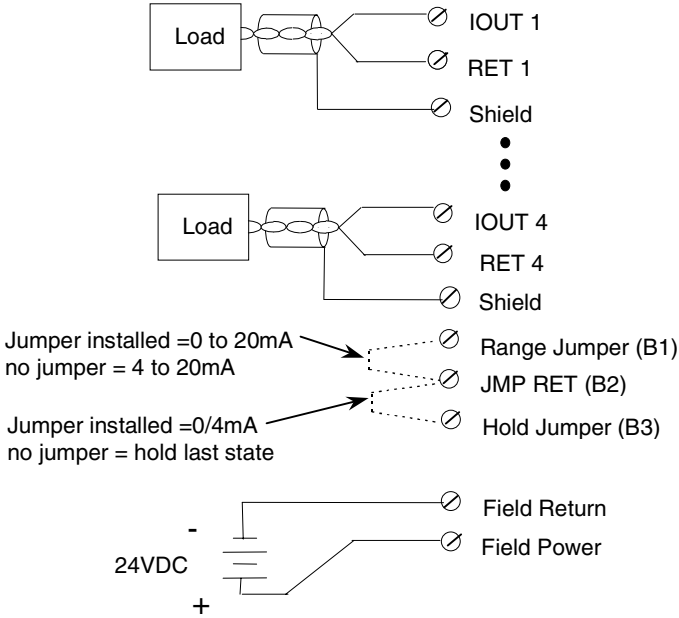

Cable Shield Connections

Shielded twisted pair cable is recommended for all of the analog channel connections. If the module is installed on a Terminal-style I/O Carrier (IC200CHS001, 002, or 005) or a Compact Terminal-style I/O Carrier (IC200CHS022, 025), the cable shield can be connected directly to the carrier per the Field Wiring Table. An Auxiliary I/O Terminal Strip (IC200TBM001, 002, or 005) can also be added to the Terminal-style I/O Carriers to aid in grounding shields. Be sure to ground the Auxiliary I/O Terminal Strip as well if you plan to use it for this purpose.

If the module is installed on a Connector-style I/O Carrier (IC200CHS003), the cable shield can be connected directly to an Interposing Terminal (IC200CHS011, 012, 015). Be sure to ground the Interposing Terminal. It is recommended to use a shielded interposing cable as well between the Interposing Terminal and the Connector Base. A custom shielded cable can be made using the Connector kit (IC200ACC302). In addition, a custom shield braid can be wrapped around standard Interposing Cables (IC200CBL105, 110, 120, 230). If this approach is used be sure to ground the braid.

All cable shield connections should be connected to earth ground and be kept as short as practical. The power cable does not need to be shielded.

IC200ALG328
Analog Output Module, 13 Bit Current, 12 Channels

Output Current Range Scaling / Step Change

In 0-20mA range mode, a current output signal value of 0mA corresponds to a %AQ value of 0 counts, and 20mA corresponds to a %AQ value of +32,000 counts. In 4-20mA range mode, a value of 0 %AQ counts corresponds to an output current of 4mA and a value of +32,000 %AQ counts corresponds to an output current of 20mA. If the module is installed in a Versamax PLC, it converts negative value commands to 0 mA regardless of range selected. If the module is controlled by a Network Interface Unit (NIU), it converts any negative value commands to the low end of range.

The illustration below shows the relationship between output signal strength and commanded %AQ counts. It depicts the step change in output current level for various command values. Not every command value results in a change in the output current level due to the module's resolution.

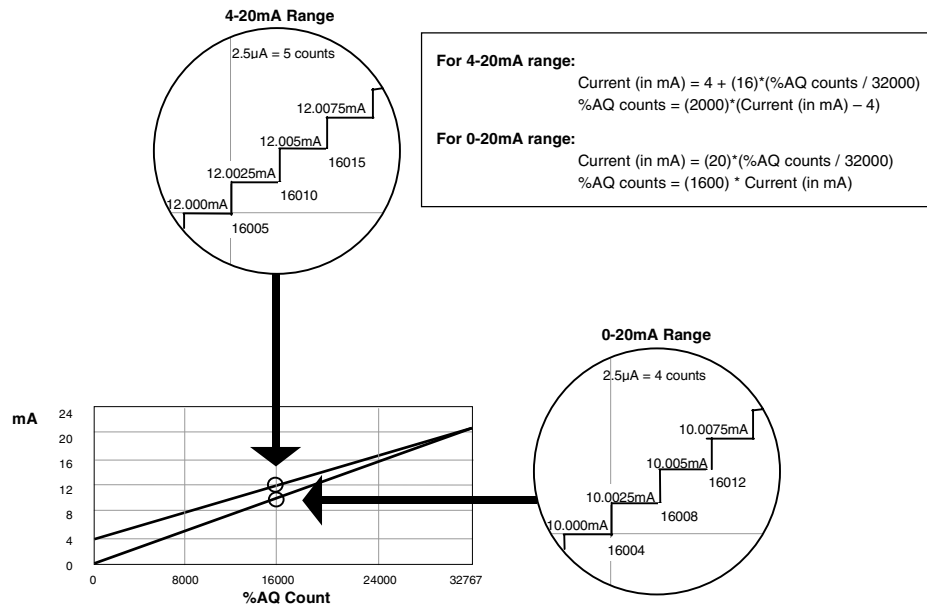

4-20 mA Range Step Change Example

Count	Current
16000	12.0000 mA
16005	12.0025 mA
16008	12.0025 mA
16009	12.0025 mA
16010	12.0050 mA

IC200ALG328
Analog Output Module, 13 Bit Current, 12 Channels

Thermal Derating

The number of channels that can be active at the same time depends on the ambient temperature, the external voltage, and the orientation of the module and DIN rail. There is no thermal derating for this module at 24V. The chart below shows thermal deratings for this module, on certain carriers, at 30VDC with the module and DIN rail in the orientations shown. There is no derating at 30V in other orientation and carrier combinations.

To meet thermal derating requirements, inactive channels should be distributed evenly across the total number of output. For example, the "A" orientation graph below reflects the derating with channels 1, 5, and 9 inactive.

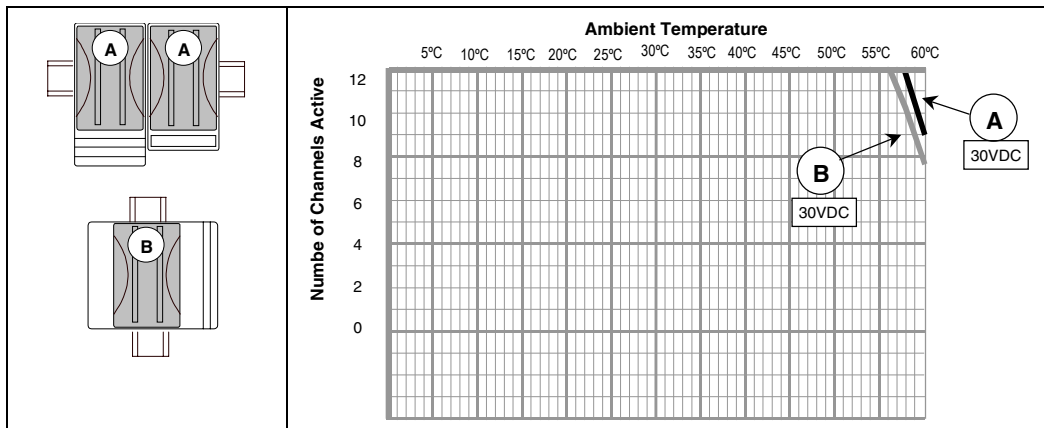

IC200ALG331 **Analog Output Module, 16 Bit Voltage/Current, 1500VAC Isolation, 4 Channels**

Analog output module IC200ALG331 provides four analog outputs. Features include:

- Four isolated 4-20mA current output channels
- Software configuration, no jumpers or switches
- Sixteen bit converter resolution
- High accuracy factory calibration

The module provides the following additional software-configurable features:

- Per-channel selection of 4-20mA current or +/-10V voltage outputs
- Selection of default/hold last state operation
- Per-channel selection of default values
- Per-channel selection of under-range and over-range diagnostics levels
- Per-channel selection of alarm levels
- Per-channel scaling
- Field re-calibration on command

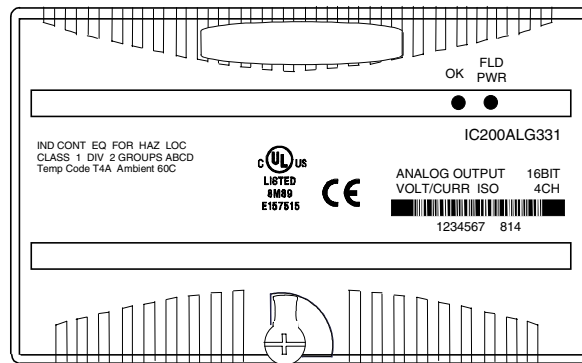

An external 24V power supply is required for the outputs. In current mode, a separate power supply may be required for isolated outputs.

The module receives 4 words of analog output data from the system CPU or NIU.

LED Indicators

The green FLD PWR LED indicates the presence of both logic power and field power for the analog field-side circuits. It does not indicate the presence of other supplies such as current loop supplies on output points. The absence of either backplane or field power turns off the FLD PWR LED. Note that this module is the only one that has the OK LED located before the FLD PWR LED in the A slot.

The OK LED indicates module status:

- On green indicates normal operation.
- Flashing green indicates boot mode or update
- Flashing amber indicates self-diagnostic error.
- Off indicates no 3.3V power

IC200ALG331

Analog Output Module, 16 Bit Voltage/Current, 1500VAC Isolation, 4 Channels

Module Specifications

Module Characteristics	
Channels	4 outputs
Module ID	FFFF9805
Isolation: User input to logic (optical) and to frame ground, Group to Group Channel to channel	250VAC continuous; 1500VAC for 1 minute Not applicable 250VAC continuous; 1500VAC for 1 minute
LED indicators	FLD PWR LED indicates the presence of both logic power and user power. OK LED indicates module status.
Backplane current consumption	5V output: 10mA maximum. 3.3V output: 115mA maximum
External power supply: Range Current consumption	+19.5 to +30VDC including ripple 100mA maximum plus load currents
Thermal derating	None
Diagnostics	High/Low Limit, Over/Underrange, Open Wire, Loss of Field Power Supply, Non-volatile memory fault
Output Characteristics	
Output operating range	Current mode: +4 to 20mA Voltage mode: +/-10VDC
Accuracy at 25 degrees C	+/- 0.1% maximum of full scale
Temperature coefficient	Current mode: 45ppm/°C typical, 90 ppm/°C maximum Voltage mode: 30ppm/°C typical, 60 ppm/°C maximum
Load characteristics	Current mode: 0 to 1250 ohms Voltage mode: 2K ohms minimum
Analog Resolution (1LSB)	Current mode: 381 nA nominal Voltage mode: 381 μ V nominal
Update rate per module	7ms maximum
Channel-to-channel crosstalk rejection	70dB minimum
Output default	Hold Last State (default) 0 (configurable)

IC200ALG331
Analog Output Module, 16 Bit Voltage/Current, 1500VAC Isolation, 4 Channels

Field Wiring

Terminal	Connection	Terminal	Connection
A1	No connection	B1	I1+
A2	Shield Termination Point	B2	I1-
A3	No connection	B3	V1+
A4	Shield Termination Point	B4	V1-
A5	No connection	B5	I2+
A6	Shield Termination Point	B6	I2-
A7	No connection	B7	V2+
A8	Shield Termination Point	B8	V2-
A9	No connection	B9	I3+
A10	Shield Termination Point	B10	I3-
A11	No connection	B11	V3+
A12	Shield Termination Point	B12	V3-
A13	No connection	B13	I4+
A14	Shield Termination Point	B14	I4-
A15	No connection	B15	V4+
A16	Shield Termination Point	B16	V4-
A17	No connection	B17	DC -
A18	No connection	B18	DC+

A 24 volt power supply must be connected to B17 and B18 to operate the module. Voltage outputs are powered from the module. For each channel, V+ is positive with respect to V- when the channel's output data is positive. Current outputs act as current regulators and require a supply to power the load. The current loop can be connected as a current source or current sink to the load. Loads are isolated if the loop supply is isolated. However, if the module supply is also used as the loop supply, the loads are not isolated.

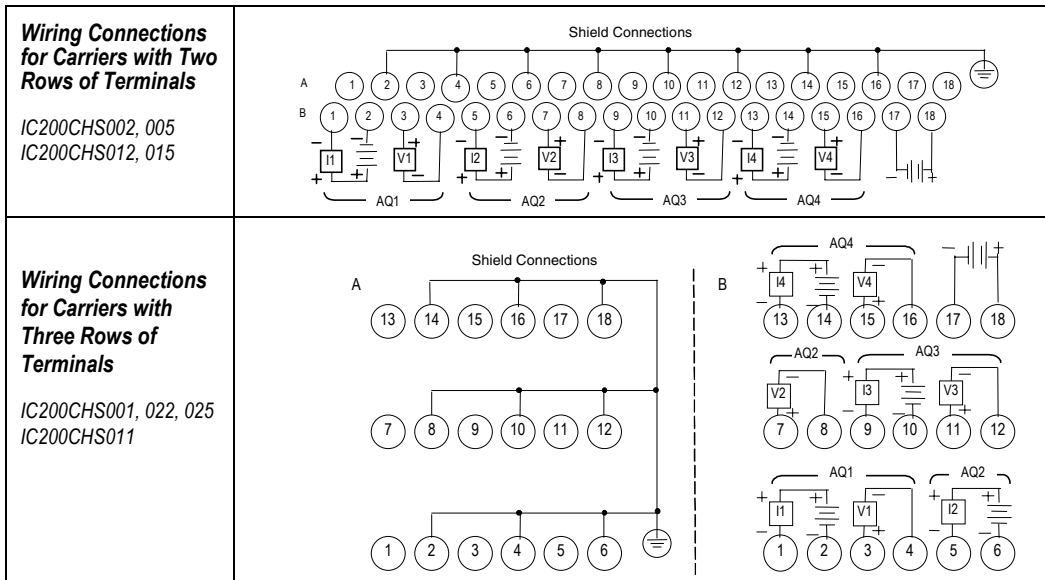

IC200ALG331

Analog Output Module, 16 Bit Voltage/Current, 1500VAC Isolation, 4 Channels

Wiring Examples

Current Source

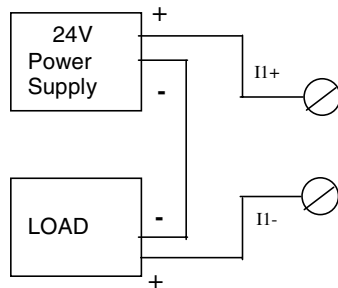

Current Sink

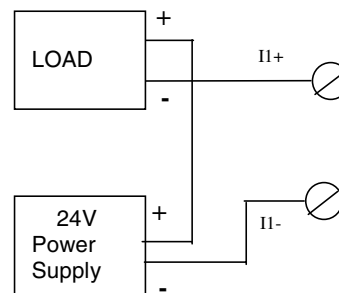

Cable Shield Connections

Shielded twisted pair cable is recommended for all of the analog channel connections. If the module is installed on a Terminal-style I/O Carrier (IC200CHS001, 002, or 005) or a Compact Terminal-style I/O Carrier (IC200CHS022, 025), the cable shield can be connected directly to the carrier per the Field Wiring Table. An Auxiliary I/O Terminal Strip (IC200TBM001, 002, or 005) can also be added to the Terminal-style I/O Carriers to aid in grounding shields. Be sure to ground the Auxiliary I/O Terminal Strip as well if you plan to use it for this purpose.

If the module is installed on a Connector-style I/O Carrier (IC200CHS003), the cable shield can be connected directly to an Interposing Terminal (IC200CHS011, 012, 015). Be sure to ground the Interposing Terminal. It is recommended to use a shielded interposing cable as well between the Interposing Terminal and the Connector Base. A custom shielded cable can be made using the Connector kit (IC200ACC302). In addition, a custom shield braid can be wrapped around standard Interposing Cables (IC200CBL105, 110, 120, 230). If this approach is used be sure to ground the braid.

All cable shield connections should be connected to earth ground and be kept as short as practical. The power cable does not need to be shielded.

IC200ALG331 **Analog Output Module, 16 Bit Voltage/Current, 1500VAC Isolation, 4 Channels**

Operation

The default parameters of this module can be used in many applications. The module can be software-configured when it is installed in a VersaMax PLC system, or an I/O Station controlled by a Network Interface Unit that is version 2.0 or above.

Output Defaults

The module requires both logic and module 24 volt power supplies to produce an output. Subsequent loss of power or communication will produce output states as determined by the configuration. These are:

Power and configuration states	Output condition
Field power, no logic power, not configured	All outputs 0
Field and logic power, not configured	All outputs 0
Field and logic power, configured	Outputs are scaled and follow program data
Module defaults due to loss of communications or other cause.	Outputs are set to configured default: value or Hold Last State. In I/O Station with NIU, outputs are set to 0.
Loss of backplane power after configuration	Outputs are set to Hold Last State if configured for Hold Last State operation, or to 0 if "default" was configured. A configured default value is not available to the module if backplane power has been lost. In I/O Station with NIU, outputs set to 0.
Communication returns without loss of Field Power	Outputs resume operation after configuration.

Calibration

The module is calibrated at the factory. For most applications, no further calibration is required. It is possible to perform recalibration in either of the following ways:

- By changing a module's scaling so its scaled data agrees with metered values.
- By sending the module a recalibration message as described in the PLC User's Manual.

IC200ALG331
Analog Output Module, 16 Bit Voltage/Current, 1500VAC Isolation, 4 Channels

Diagnostics

By default, the module is configured for fault reporting. The module reports faults as soon as they are detected. Once a fault has been reported, the same fault is not reported again until the fault has been cleared. Fault reporting can be disabled via configuration. If disabled, faults are not reported. The module can detect and report the following faults:

Over-Range

The module reports an Over Range fault if an output value is greater than approximately +12.5 volts or 25 mA.

Under-Range

The module reports an Under Range fault if an output value is approximately 0mA on a current channel or -12.5 volts on a voltage channel.

Open Wire

The module reports an Open Wire fault on current outputs if the configuration of the low end of the range is greater than or equal to approximately 2.0 mA, but the output is not detecting current.

Loss of Field Power Supply

The module reports a Loss of Field Power fault if field power is not present (also indicated by the FLD PWR LED). Outputs default as specified by the configuration.

High Limit

The module reports a High Alarm fault if an output value is greater than or equal to the value specified by the “Alarm High” configuration parameter.

Low Limit

The module reports a Low Alarm fault if an output value is less than or equal to the value specified by the “Alarm Low” configuration parameter.

Non-volatile Memory Fault

The module reports this fault only during field recalibration, if a non-volatile memory fault is detected.

IC200ALG331
Analog Output Module, 16 Bit Voltage/Current, 1500VAC Isolation, 4 Channels

Configurable Parameters

The default parameters of this module can be used in many applications. The module can be software-configured when it is installed in a VersaMax PLC system, or an I/O Station controlled by a Network Interface Unit that is version 2.0 or above.

Module Parameter	Description	Default	Choices
Analog Output Data Reference	Starting offset for the module's analog output data.		user selectable
Analog Output Data Length	Word length of the module's analog output data.	4	0–4
Report Faults	Enables or disables Fault Reporting for the entire Module.	Enabled	Enabled, Disabled
%AQ Default /Hold Last State	Specifies whether the module will go to the specified channel defaults (see below) or hold their last states if power or communications are lost.	Default	Default /Hold
Current / Voltage	Specifies whether the channel will be a voltage or current output. If the Channel type is Current, the range is 4 to 20mA. If Channel type is Voltage, the range is –10 to +10V.	I (Current)	I (Current), V (Voltage)
Channel Active	Specifies if the channel should output data received from the CPU or NIU. If a channel is "inactive" space is still allocated for it.	Active	Inactive (off), Active (on)
Span Low	Actual current (in microAmps) or voltage (in milliVolts) to be scaled to low engineering units value.	4000 μ A	0 to 25,000 μ A –10,000 to +10,000mV
Span High	Actual current in microAmps or voltage in millivolts to be scaled to the high engineering units value.	20000 μ A	0 to 25,000 μ A –10,000 to +10,000mV
Engineering Low	The engineering units value that is considered equivalent to the low span (actual) value.	4000	0 to 25,000 μ A –10,000 to +10,000mV
Engineering High	The engineering units value that is considered equivalent to the high span (actual) value.	20000	0 to 25,000 μ A –10,000 to +10,000mV
Default	The value to be output by the firmware when the module is in a default condition and the Output Default Control is set to Default.	0 μ A	-32768 to +32767

IC200ALG331

Analog Output Module, 16 Bit Voltage/Current, 1500VAC Isolation, 4 Channels

Configuring Scaling

The module converts digital output values received from the CPU or NIU to electrical signals (either current or voltage, as configured). By default, the module converts this data to 1 millivolt or 1 microamp “internal units” for convenience in scaling and comparing to actual meter measurements.

The module’s default scaling can be changed to tailor the output data to a specific application. Typically, engineering units represent millivolts or microamps. But they may also represent physical units such as degrees or centimeters per second. When reconfiguring scaling, it is important to be sure that the chosen Engineering Units values would not result in Overrange or Underrange output levels.

The scaling for each channel can be configured independently. Scaling is configured by selecting corresponding low and high engineering units values and low and high internal values (counts) for two points.

During operation, the module will use the straight line defined by these two pairs of configured scaling values to convert internal values to current or voltage signal levels that represent appropriate engineering units.

Scaling Values for 1mV or 1μA Engineering Units

For many applications, the engineering units are either millivolts or microAmps. These units are easy to scale. Simply use the table below to find scaling values that are appropriate for the channel’s configured range.

Examples	Output Range	Enter this engineering units value	Span Units (microAmps)
4 mA to 20 mA	4 mA 20 mA	Low +4,000 High +20,000	Low +4,000 High +20,000
-10 volts to +10 volts	0 volts +10 volts	Low 0 High +10,000	Low +4,000 High +20,000
0 mA to 20 mA	0 mA 20 mA	Low 0 High +20,000	Low 0 High +20,000
-10 volts to +10 volts	-5 volts +10 volts	Low -5,000 High +10,000	Low -5,000 High +10,000

IC200ALG331
Analog Output Module, 16 Bit Voltage/Current, 1500VAC Isolation, 4 Channels

Scaling Example

A channel is configured in the 0 to 10 volts DC range. It measures a velocity output. Electronic sensors and mechanical linkage external to the module have determined that an output level of +1.5 volts DC is equal to -20 feet/second (-6 meters/second), and that +9 volts DC is equal to +180 feet/second (+50 meters/second). Plotting these values on a graph shows that a signal of 5 volts DC corresponds to a speed of 73.3 feet/second.

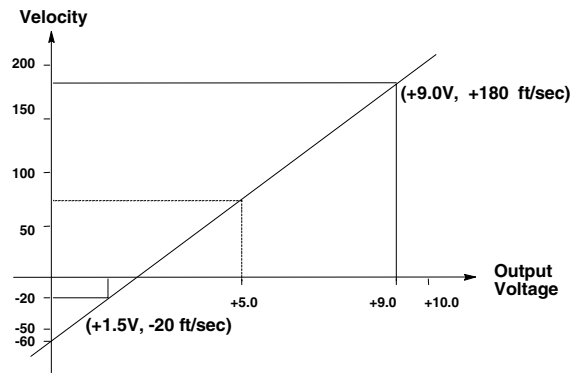

For engineering units of feet per second, the following scaling values are used:

Low engineering units	=	-20	ft/sec
High engineering units	=	+180	ft/sec
Low span units	=	1500	millivolts
High span units	=	9000	millivolts

An output value of 5.0 volts would be scaled to an engineering value of +00073 (ft/sec).

In this example, scaling to hundredths of feet per second would provide better resolution. The following scaling values would be used:

Low engineering units	=	-2000	hundredths ft/sec
High engineering units	=	+1800	hundredths ft/sec
Low span units	=	1500	millivolts
High span units	=	9000	millivolts

An output value of 5.0 volts would be scaled to an engineering value of +7333 (hundredths of ft/sec).

Chapter 12

Analog Mixed I/O Modules

This chapter describes analog mixed input/output modules.

- IC200ALG430 Analog Mixed Module, 12 Bit Input Current 4 Channels and Output Current 2 Channels
- IC200ALG431 Analog Mixed Module, 12 Bit 0 to 10VDC Input 4 Channels and Output 2 Channels
- IC200ALG432 Analog Mixed Module, 12 Bit +/-10VDC Input 4 Channels and Output 2 Channels

IC200ALG430 **Analog Mixed Module, 12 Bit Input Current 4 Channels and** **Output Current 2 Channels**

Analog mixed module IC200ALG430 provides four analog current inputs and two analog current outputs.

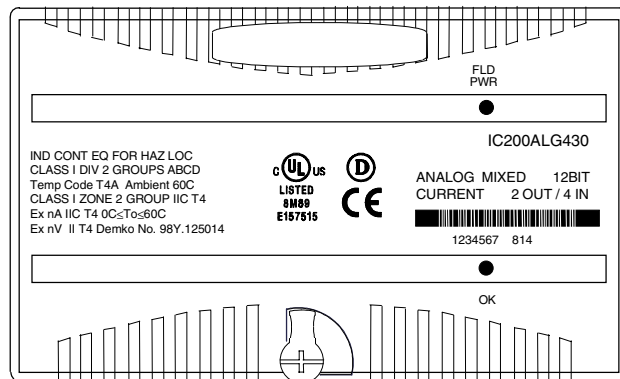

An external 24V power supply is required for the outputs. For inputs, power for the user's transceivers must be supplied from an external source.

Intelligent processing for this module is performed by the CPU or Network Interface Unit. The module provides 4 words of analog input data and receives 2 words of analog output data.

LED Indicators

The green FLD PWR LED indicates the presence of user-side power for the analog field-side circuits. The green OK LED is on when backplane power is present to the module.

Diagnostics

The module reports a Loss of User Side Power fault for field-side circuits.

I/O Defaults

The module is easily set up with a jumper for the outputs to either hold their last states or default to 4mA if backplane power or communications are interrupted or the PLC is stopped. External user power must remain uninterrupted. Outputs remain in their default or last state until the module receives different output data from the backplane, or until field power is removed.

When software-configured, inputs can be configured to hold last state or report a selectable value. When the module is autoconfigured using a CPU or NIU that is version 2.x or later, inputs default to 0. If the CPU or NIU is version 1.5 or earlier, the input default matches the jumper-configured output default (0 or Hold Last State).

IC200ALG430
**Analog Mixed Module, 12 Bit Input Current 4 Channels and
Output Current 2 Channels**

Module Specifications

Module Characteristics	
Channels	4 differential inputs, one group, 2 single-ended outputs, one group
Module ID	FFFF9424
Isolation:	
User input to logic (optical) and to frame ground	250VAC continuous; 1500VAC for 1 minute
Group to group	Not applicable
Channel to channel	None
LED indicators	FLD PWR LED indicates field power is present OK LED indicates backplane power is present
Backplane current consumption	5V output: 50mA maximum
Thermal derating	None
Configuration parameters	Output default
Diagnostics	Loss of User Side Power
External Power Supply	
Recommended Range	+18 to +30VDC (including ripple)
Current consumption at recommended range	160mA max.(including load current)
12V operation range	9.6 to 15VDC, 12VDC nominal (including ripple)
Current consumption at 12V range	215mA max.(including load current)
Input Characteristics	
Input current	4 to 20mA
Input Impedance	200 Ohms maximum
Accuracy (0V Common Mode Voltage) at:	
25 degrees C**	+/-0.3% typ. of full scale, +/-0.5% max. of full scale
0 to 60 degrees C	+/-1% maximum of full scale
Resolution:	4 μ A = 8 counts
Filter response	5.0ms
Update rate per module	0.4ms
Common mode voltage	<30V
Channel-to-channel crosstalk rejection	30dB minimum
Output Characteristics	
Output current	4 to 20mA
Load characteristics:	
Resistive	0 to 1250 Ohms maximum*
Capacitive	0.1 μ F maximum
Inductive	0.5H maximum
Accuracy at 25 degrees C**	+/- 0.3% typ. of full scale, +/- 0.5% max. of full scale
Accuracy at 0 to 60 degrees C	+/-1% maximum of full scale
Resolution	4 μ A = 8 counts
Update rate per module	0.3ms maximum
Channel-to-channel crosstalk rejection	70dB minimum
Output default	Hold Last State (default), 4mA (configurable)

* $R_{L(MAX)} = (V_{EXTERNAL PS} - 4V) / 20.38mA$

** In the presence of severe RF interference, (IEC1999-4-3, 10V/m), accuracy degraded to +/-1% maximum of full scale. Input accuracy may be degraded an additional +/-0.75% with the introduction of input common mode voltage.

IC200ALG430
Analog Mixed Module, 12 Bit Input Current 4 Channels and
Output Current 2 Channels

Field Wiring

Terminal assignments for the module are shown below.

Terminal	Connection	Terminal	Connection
A1	I OUT 1	B1	No connection
A2	RET 1	B2	Shield Termination Point
A3	I OUT 2	B3	No connection
A4	RET 2	B4	Shield Termination Point
A5	I IN 1+	B5	No connection
A6	I IN 1-	B6	Shield Termination Point
A7	I IN 2+	B7	No connection
A8	I IN 2-	B8	Shield Termination Point
A9	I IN 3+	B9	No connection
A10	I IN 3-	B10	Shield Termination Point
A11	I IN 4+	B11	No connection
A12	I IN 4-	B12	Shield Termination Point
A13	No connection	B13	JMP1A
A14	No connection	B14	JMP1B
A15	No connection	B15	No connection
A16	No connection	B16	No connection
A17	Field Return	B17	No connection
A18	Field Power	B18	No connection

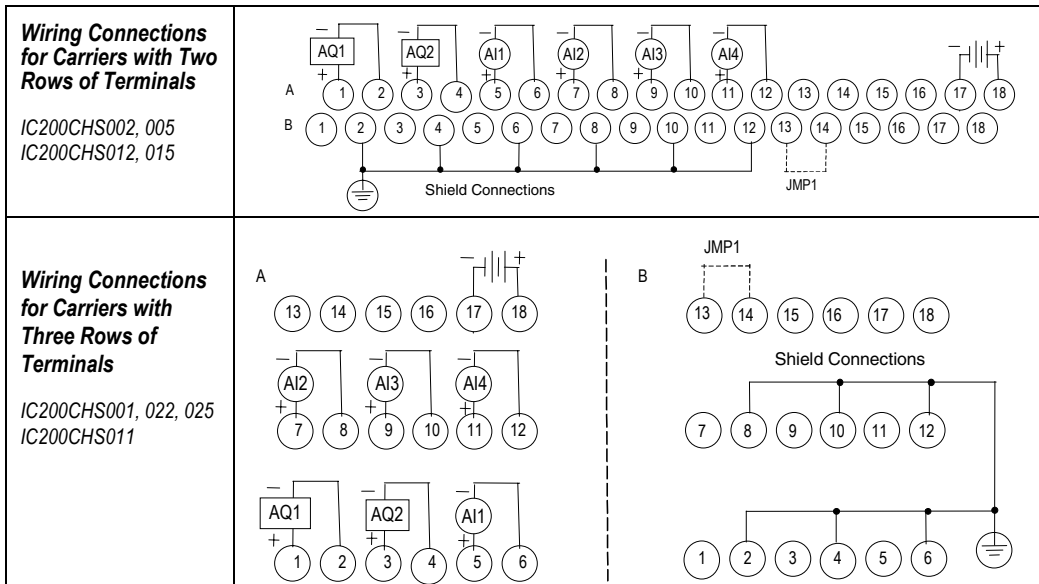

IC200ALG430

Analog Mixed Module, 12 Bit Input Current 4 Channels and Output Current 2 Channels

Jumper Selection

A jumper on the carrier can be used to select the output default mode. If no jumper is installed on pins B13 and B14 outputs hold their last state (the last commanded value from the backplane) if backplane power or communications are interrupted or the PLC is stopped. With a jumper installed, if such conditions occur outputs default to 4mA. This should only be changed with field power and backplane power removed.

Jumper	Selects
None	Hold Last State
JMP 1	Default to 4mA

Wiring Examples

Current Inputs

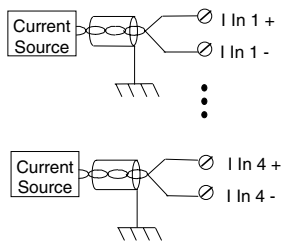

An external source is needed to power input transceivers.

Current Outputs

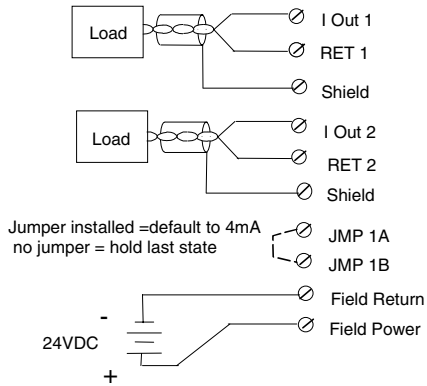

IC200ALG430
Analog Mixed Module, 12 Bit Input Current 4 Channels and
Output Current 2 Channels**Cable Shield Connections**

Shielded twisted pair cable is recommended for all of the analog channel connections. If possible, the analog input channel connections should be grounded at the source device. If that is not possible, the cable shield must be grounded at the I/O module.

If the module is installed on a Terminal-style I/O Carrier (IC200CHS001, 002, or 005) or a Compact Terminal-style I/O Carrier (IC200CHS022, 025), the cable shield can be connected directly to the carrier per the Field Wiring Table. An Auxiliary I/O Terminal Strip (IC200TBM001, 002, or 005) can also be added to the Terminal-style I/O Carriers to aid in grounding shields. Be sure to ground the Auxiliary I/O Terminal Strip as well if you plan to use it for this purpose.

If the module is installed on a Connector-style I/O Carrier (IC200CHS003), the cable shield can be connected directly to an Interposing Terminal (IC200CHS011, 012, 015). Be sure to ground the Interposing Terminal. It is recommended to use a shielded interposing cable as well between the Interposing Terminal and the Connector Base. A custom shielded cable can be made using the Connector kit (IC200ACC302). In addition, a custom shield braid can be wrapped around standard Interposing Cables (IC200CBL105, 110, 120, 230). If this approach is used be sure to ground the braid.

All cable shield connections should be connected to earth ground and be kept as short as practical. The power cable does not need to be shielded.

IC200ALG430

**Analog Mixed Module, 12 Bit Input Current 4 Channels and
Output Current 2 Channels**

Scaling

The following graphs show the relationship between the input current measured at the field terminals and the data values for the module.

Count vs Input Current

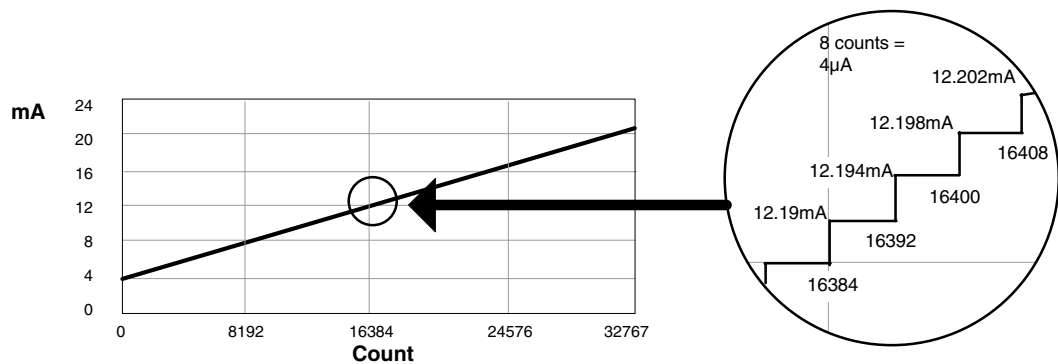

The following equation can be used to calculate counts values:

$$\text{Counts} = (\text{Current in mA} - 4\text{mA}) \times (32768 / 16.38\text{mA})$$

For a change to be seen in the reported count value, input current must be increased by at least 4µA. If the module receives an increase less than 4µA, the previous count value is still reported. For example:

Current	Count
12.190mA	16384
12.192mA	16384
12.194mA	16392

**IC200ALG430
Analog Mixed Module, 12 Bit Input Current 4 Channels and
Output Current 2 Channels**

Count vs Output Current

The graph below shows the relationship between the output data that is provided to the module from the backplane, and the actual output current. The range spans between 4mA and 20mA.

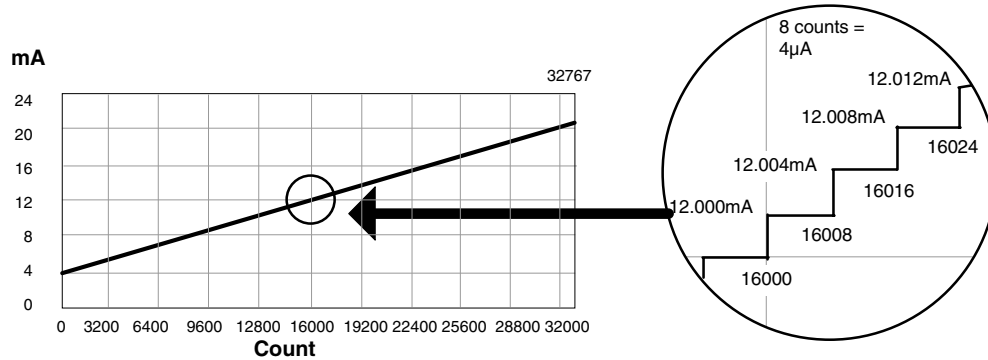

The following equation can be used to calculate specific output currents:

$$I_{out} = 4mA + (count/32760) \times 16.38mA$$

The count value must be a multiple of 8. If the module receives a count value that is not a multiple of 8, it rounds the value down to the closest multiple of 8. For example:

Count	mA
16000	12.000
16007	12.000
16008	12.004

IC200ALG431

Analog Mixed Module, 12 Bit 0 to 10VDC Input 4 Channels and Output 2 Channels

Analog mixed module IC200ALG431 provides four 0 to +10VDC analog inputs and two 0 to +10VDC analog outputs.

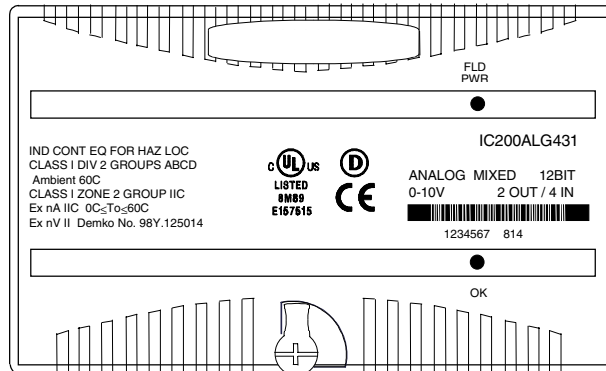

An external 24V power supply is required for the outputs. For inputs, power for the user's transceivers must be supplied from an external source.

Intelligent processing for this module is performed by the CPU or Network Interface Unit. The module provides 4 words of analog input data and receives 2 words of analog output data.

LED Indicators

The green FLD PWR LED indicates the presence of user-side power for the analog field-side circuits. The green OK LED is on when backplane power is present to the module.

Diagnostics

The module reports a Loss of User Side Power fault for field-side circuits.

I/O Defaults

The module is easily set up with a jumper for the outputs to either hold their last states or default to 0V if backplane power or communications are interrupted or the PLC is stopped. External user power must remain uninterrupted. Outputs remain in their default or last state until the module receives different output data from the backplane, or until field power is removed.

When software-configured, inputs can be configured to hold last state or report a selectable value. When the module is autoconfigured using a CPU or NIU that is version 2.x or later, inputs default to 0. If the CPU or NIU is version 1.5 or earlier, the input default matches the jumper-configured output default (0 or Hold Last State).

IC200ALG431
Analog Mixed Module, 12 Bit 0 to 10VDC Input 4 Channels and Output 2 Channels

Module Specifications

Module Characteristics	
Channels	4 single-ended inputs, one group, 2 single-ended outputs, one group
Module ID	FFFF9024
Isolation:	
User input to logic (optical) and to frame ground	250VAC continuous; 1500VAC for 1 minute
Group to group	Not applicable
Channel to channel	None
LED indicators	FLD PWR LED indicates field power is present OK LED indicates backplane power is present
Backplane current consumption	5V output: 60mA maximum
Thermal derating	None
Configuration parameters	Output default
Diagnostics	Loss of User Side Power
External Power Supply	
Recommended range	+18 to +30VDC (including ripple)
Current consumption at recommended range	160mA max.(including load current)
12V operation range	9.6 to 15VDC, 12VDC nominal (including ripple)
Current consumption at 12V range	175mA max.(including load current)
Input Characteristics	
Input voltage:	0 to 10V
Input Impedance	120kOhms minimum
Accuracy at 25 degrees C*	+/-0.3% typical of full scale, +/-0.5% maximum of full scale
Accuracy at 0 to 60 degrees C	+/-1% maximum of full scale
Resolution:	2.5mV = 8 counts
Filter response	5.0ms
Update rate per module	0.4ms
Common mode voltage	0 V
Channel-to-channel crosstalk rejection	30dB minimum
Output Characteristics	
Output voltage	0 to 10.24VDC
Load characteristics:	
Resistive	5000 Ohms minimum
Capacitive	1.0μF maximum
Accuracy at 25 degrees C*	+/- 0.3% typical of full scale, +/- 0.5% maximum of full scale
Accuracy at 0 to 60 degrees C	+/-1% maximum of full scale
Resolution	2.5mV = 8 counts
Update rate per module	0.3ms maximum
Channel-to-channel crosstalk rejection	70dB minimum
Output default	Hold Last State (configurable), 0 (default)

* In the presence of severe RF interference, (IEC 1000-4-3, 10V/m), accuracy may be degraded to +/-1%.

IC200ALG431

Analog Mixed Module, 12 Bit 0 to 10VDC Input 4 Channels and Output 2 Channels

Field Wiring

Terminal	Connection	Terminal	Connection
A1	V OUT 1	B1	No connection
A2	V OUT Return	B2	Shield Termination Point
A3	V OUT 2	B3	No connection
A4	V OUT Return	B4	Shield Termination Point
A5	V IN 1	B5	No connection
A6	V IN Return	B6	Shield Termination Point
A7	V IN 2	B7	No connection
A8	V IN Return	B8	Shield Termination Point
A9	V IN 3	B9	No connection
A10	V IN Return	B10	Shield Termination Point
A11	V IN 4	B11	No connection
A12	V IN Return	B12	Shield Termination Point
A13	No connection	B13	JMP1A
A14	No connection	B14	JMP1B
A15	No connection	B15	No connection
A16	No connection	B16	No connection
A17	Field Return	B17	No connection
A18	Field Power	B18	No connection

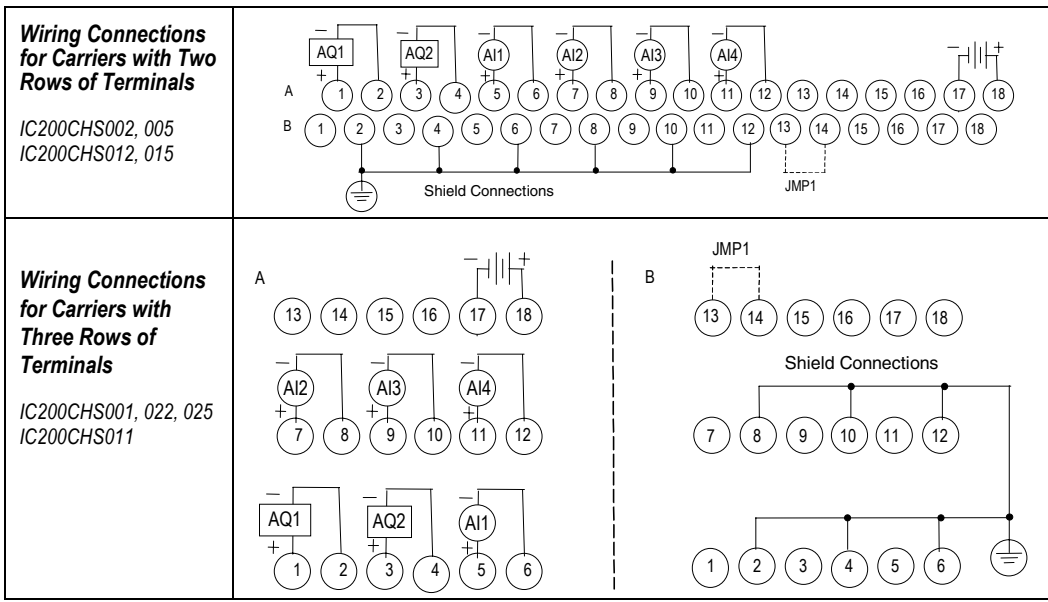

IC200ALG431
Analog Mixed Module, 12 Bit 0 to 10VDC Input 4 Channels and Output 2 Channels

Jumper Selection

A jumper on the carrier can be used to select the output default mode. If no jumper is installed on pins B13 and B14 outputs hold their last state (the last commanded value from the backplane) if backplane power or communications are interrupted or the PLC is stopped. With a jumper installed, if such conditions occur outputs default to 0 volts. This should only be changed with field power and backplane power removed.

Jumper	Selects
None	Hold Last State
JMP 1	Default to 0

Wiring Examples

Voltage Inputs

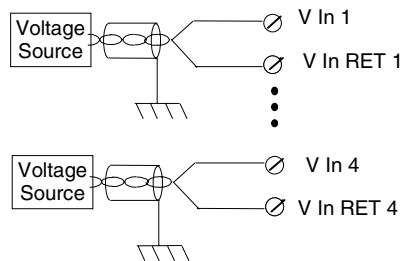

An external source is needed to power input transceivers.

Voltage Outputs

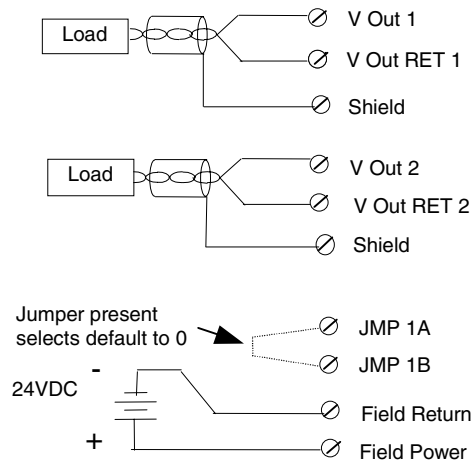

IC200ALG431
Analog Mixed Module, 12 Bit 0 to 10VDC Input 4 Channels and Output 2 Channels**Cable Shield Connections**

Shielded twisted pair cable is recommended for all of the analog channel connections. If possible, the analog input channel connections should be grounded at the source device. If that is not possible, the cable shield must be grounded at the I/O module.

If the module is installed on a Terminal-style I/O Carrier (IC200CHS001, 002, or 005) or a Compact Terminal-style I/O Carrier (IC200CHS022, 025), the cable shield can be connected directly to the carrier per the Field Wiring Table. An Auxiliary I/O Terminal Strip (IC200TBM001, 002, or 005) can also be added to the Terminal-style I/O Carriers to aid in grounding shields. Be sure to ground the Auxiliary I/O Terminal Strip as well if you plan to use it for this purpose.

If the module is installed on a Connector-style I/O Carrier (IC200CHS003), the cable shield can be connected directly to an Interposing Terminal (IC200CHS011, 012, 015). Be sure to ground the Interposing Terminal. It is recommended to use a shielded interposing cable as well between the Interposing Terminal and the Connector Base. A custom shielded cable can be made using the Connector kit (IC200ACC302). In addition, a custom shield braid can be wrapped around standard Interposing Cables (IC200CBL105, 110, 120, 230). If this approach is used be sure to ground the braid.

All cable shield connections should be connected to earth ground and be kept as short as practical. The power cable does not need to be shielded.

IC200ALG431
Analog Mixed Module, 12 Bit 0 to 10VDC Input 4 Channels and Output 2 Channels

Scaling

The following graphs show the relationship between the voltage applied at the field terminals and the data values for the module.

Count vs Input Voltage

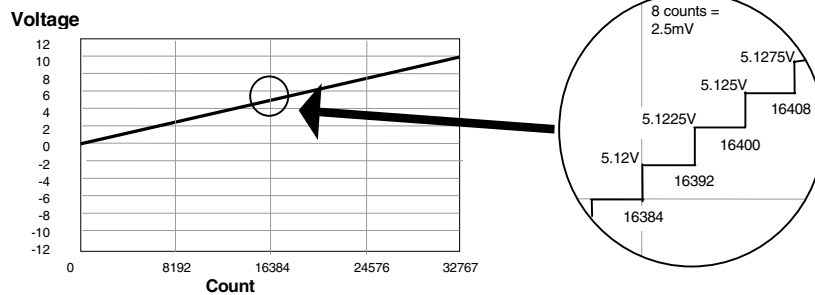

The following equation can be used to calculate counts values:

$$\text{Counts} = (\text{Voltage In}) \times (3200)$$

The count value is returned as a multiple of 8. A voltage that would return a count value (using the above equation) which is not a multiple of 8 will return the next highest multiple of 8.

Input Voltage	Count
5.1200	16384
5.1210	16392
5.1220	16392
5.1225	16392

IC200ALG431

Analog Mixed Module, 12 Bit 0 to 10VDC Input 4 Channels and Output 2 Channels

Count vs Output Voltage

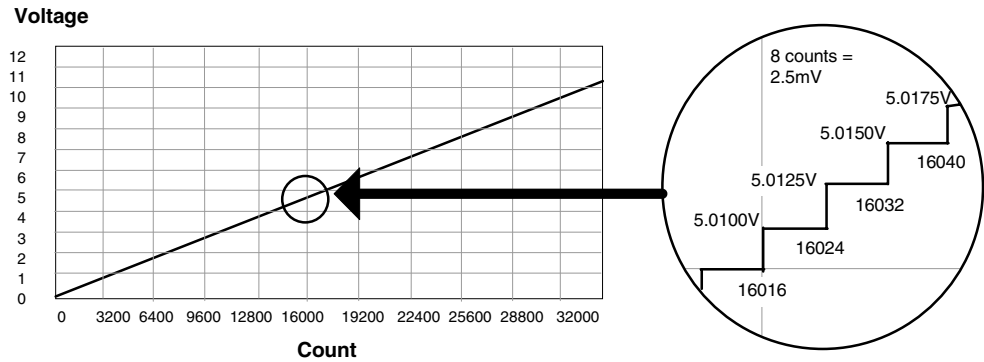

Voltage can be calculated using the following equation:

$$V_{out} = (\text{analog counts} \times 10.25) / 32768)$$

The count value must be a multiple of 8. If the module receives a count value that is not a multiple of 8, it rounds the value down to the closest multiple of 8. For example:

Count	Voltage
16024	5.0125V
16030	5.0125V
16032	5.0150V

IC200ALG432 **Analog Mixed Module, 12 Bit +/-10VDC Input 4 Channels and Output 2 Channels**

Analog mixed module IC200ALG432 provides four -10 to +10VDC analog inputs and two -10 to +10VDC analog outputs.

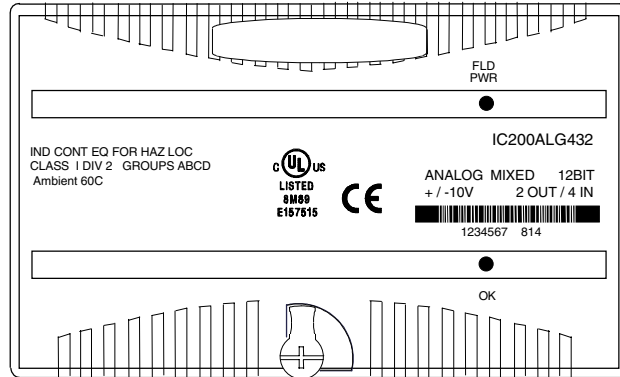

An external 24V power supply is required for the outputs. For inputs, power for the user's transceivers must be supplied from an external source. Intelligent processing for this module is performed by the CPU or Network Interface Unit. The module provides 4 words of analog input data and receives 2 words of analog output data.

LED Indicators

The green FLD PWR LED indicates the presence of user-side power for the analog field-side circuits.

The green OK LED is on when backplane power is present to the module.

Diagnostics

The module reports a Loss of User Side Power fault for field-side circuits.

I/O Defaults

The module is easily set up with a jumper for the outputs to either hold their last states or default to 0V if backplane power or communications are interrupted or the PLC is stopped. External user power must remain uninterrupted. Outputs remain in their default or last state until the module receives different output data from the backplane, or until field power is removed.

When software-configured, inputs can be configured to hold last state or report a selectable value. When the module is autoconfigured using a CPU or NIU that is version 2.x or later, inputs default to 0. If the CPU or NIU is version 1.5 or earlier, the input default matches the jumper-configured output default (0 or Hold Last State).

IC200ALG432

Analog Mixed Module, 12 Bit +/-10VDC Input 4 Channels and Output 2 Channels

Module Specifications

Module Characteristics	
Channels	4 single-ended inputs, one group, 2 single-ended outputs, one group
Module ID	FFFF9024
Isolation:	
User input to logic (optical) and to frame ground	250VAC continuous; 1500VAC for 1 minute
Group to group	Not applicable
Channel to channel	None
LED indicators	FLD PWR LED indicates field power is present OK LED indicates backplane power is present
Backplane current consumption	5V output: 60mA maximum
Thermal derating	None
Configuration parameters	Output default
Diagnostics	Loss of User Side Power
External Power Supply	
Recommended range	+18 to +30VDC (including ripple)
Current consumption at recommended range	160mA max.(including load current)
12V operation range	9.6 to 15VDC, 12VDC nominal (including ripple)
Current consumption at 12V range	175mA max.(including load current)
Input Characteristics	
Input voltage:	+/-10VDC
Input Impedance	125kOhms minimum
Accuracy at 25 degrees C*	+/-0.3% typ. of full scale, +/-0.5% max. of full scale
Accuracy at 0 to 60 degrees C	+/-1% maximum of full scale
Resolution:	2.5mV = 8 counts
Filter response	5.0ms
Update rate per module	0.4ms
Common mode voltage	0 V
Channel-to-channel crosstalk rejection	30dB minimum
Output Characteristics	
Output voltage	+/-10.24VDC
Load characteristics:	
Resistive	5000 Ohms minimum
Capacitive	1.0μF maximum
Accuracy at 25 degrees C*	+/- 0.3% typ. of full scale, +/- 0.5% max. of full scale
Accuracy at 0 to 60 degrees C	+/-1% maximum of full scale
Resolution	5mV = 16 counts
Update rate per module	0.3ms maximum
Channel-to-channel crosstalk rejection	70dB minimum
Output default	Hold Last State (default), 0 (configurable)

* In the presence of severe RF interference, (IEC 1000-4-3, 10V/m), accuracy may be degraded to +/-1%.

IC200ALG432
Analog Mixed Module, 12 Bit +/-10VDC Input 4 Channels and Output 2 Channels

Field Wiring

Terminal	Connection	Terminal	Connection
A1	V OUT 1	B1	No connection
A2	V OUT Return	B2	Shield Termination Point
A3	V OUT 2	B3	No connection
A4	V OUT Return	B4	Shield Termination Point
A5	V IN 1	B5	No connection
A6	V IN Return	B6	Shield Termination Point
A7	V IN 2	B7	No connection
A8	V IN Return	B8	Shield Termination Point
A9	V IN 3	B9	No connection
A10	V IN Return	B10	Shield Termination Point
A11	V IN 4	B11	No connection
A12	V IN Return	B12	Shield Termination Point
A13	No connection	B13	JMP1A
A14	No connection	B14	JMP1B
A15	No connection	B15	No connection
A16	No connection	B16	No connection
A17	Field Return	B17	No connection
A18	Field Power	B18	No connection

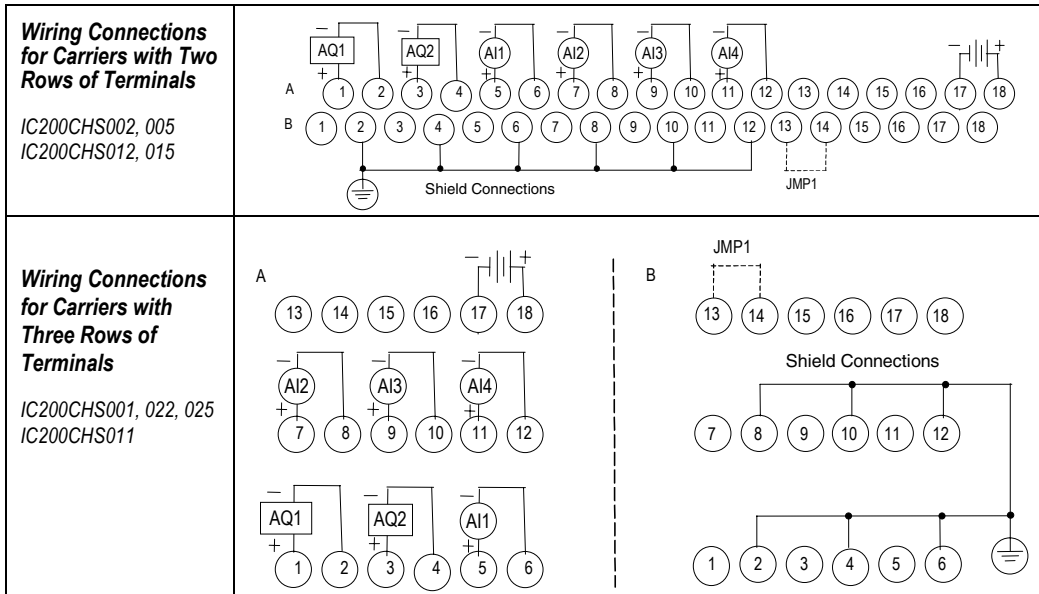

IC200ALG432

Analog Mixed Module, 12 Bit +/-10VDC Input 4 Channels and Output 2 Channels

Jumper Selection

If no jumper is installed outputs hold their last state (the last commanded value from the backplane) if backplane power or communications are interrupted or the PLC is stopped. With a jumper installed, if such conditions occur outputs default to 0V. This should only be changed with field power and backplane power removed.

Jumper	Default
None	Hold Last State
JMP 1	0V

Wiring Example

Voltage Inputs

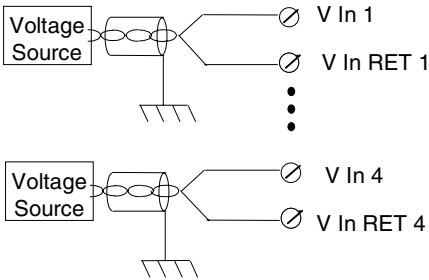

An external source is needed to power input transceivers.

Voltage Outputs

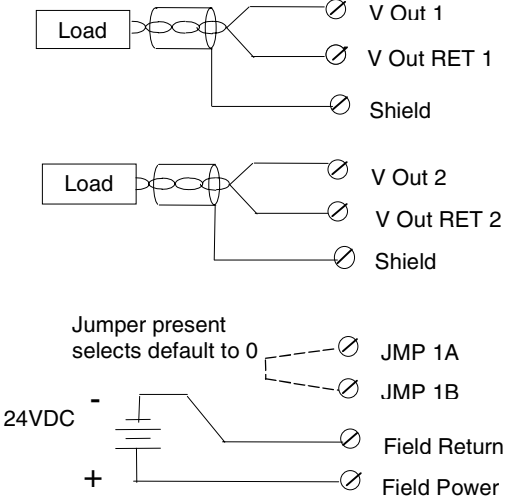

IC200ALG432
Analog Mixed Module, 12 Bit +/-10VDC Input 4 Channels and Output 2 Channels**Cable Shield Connections**

Shielded twisted pair cable is recommended for all of the analog channel connections. If possible, the analog input channel connections should be grounded at the source device. If that is not possible, the cable shield must be grounded at the I/O module.

If the module is installed on a Terminal-style I/O Carrier (IC200CHS001, 002, or 005) or a Compact Terminal-style I/O Carrier (IC200CHS022, 025), the cable shield can be connected directly to the carrier per the Field Wiring Table. An Auxiliary I/O Terminal Strip (IC200TBM001, 002, or 005) can also be added to the Terminal-style I/O Carriers to aid in grounding shields. Be sure to ground the Auxiliary I/O Terminal Strip as well if you plan to use it for this purpose.

If the module is installed on a Connector-style I/O Carrier (IC200CHS003), the cable shield can be connected directly to an Interposing Terminal (IC200CHS011, 012, 015). Be sure to ground the Interposing Terminal. It is recommended to use a shielded interposing cable as well between the Interposing Terminal and the Connector Base. A custom shielded cable can be made using the Connector kit (IC200ACC302). In addition, a custom shield braid can be wrapped around standard Interposing Cables (IC200CBL105, 110, 120, 230). If this approach is used be sure to ground the braid.

All cable shield connections should be connected to earth ground and be kept as short as practical. The power cable does not need to be shielded.

IC200ALG432

Analog Mixed Module, 12 Bit +/-10VDC Input 4 Channels and Output 2 Channels

Scaling

The following graphs show the relationship between the voltage applied at the field terminals and the data values for the module.

Count vs Input Voltage

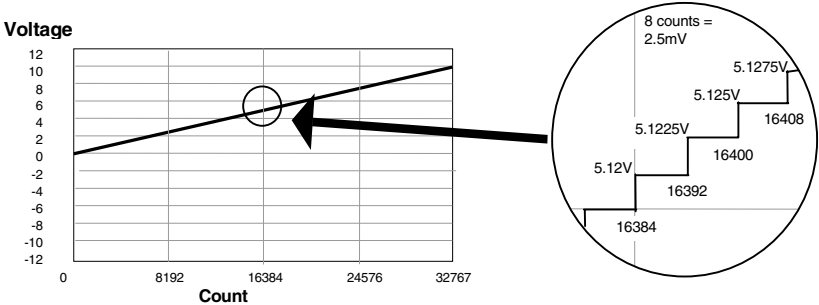

The following equation can be used to calculate counts values:

$$\text{Counts} = (\text{Voltage In}) \times (3200)$$

The count value is returned as a multiple of 8. A voltage that would return a count value (using the above equation) which is not a multiple of 8 will return the next highest multiple of 8.

Input Voltage	Count
5.1200	16384
5.1210	16392
5.1220	16392
5.1225	16392

IC200ALG432
Analog Mixed Module, 12 Bit +/-10VDC Input 4 Channels and Output 2 Channels

Count vs Output Voltage

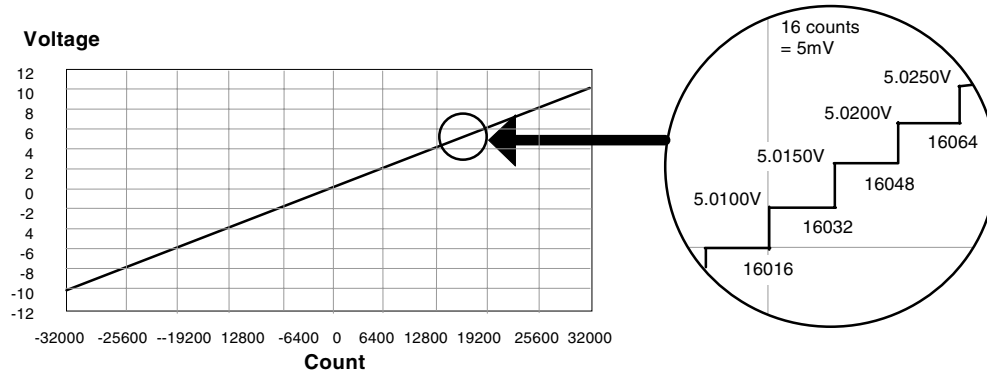

Voltage can be calculated using the following equation:

$$V_{out} = (\text{analog counts} \times 20.5) / 65535$$

The count value must be a multiple of 16. If the module receives a count value that is not a multiple of 16, it rounds the value down to the closest multiple of 16. For example:

Count	Voltage
16032	5.0150V
16040	5.0150V
16048	5.0200V

Chapter
13

Mixed Discrete/High-speed Counter Module

This chapter describes the following VersaMax Mixed Discrete Module.

- IC200MDD841 Mixed Module, 24VDC Positive Logic Input 20 Points / Output 12 Point / (4) High Speed Counter, PWM, or Pulse Train Configurable Points

IC200MDD841
Mixed Module, 24VDC Positive Logic Input 20 Points / Output 12 Point /
(4) High Speed Counter, PWM, or Pulse Train Configurable Points

Discrete I/O module IC200MDD841 has twenty 24VDC positive-logic type inputs and twelve positive-logic 24VDC 0.5Amp outputs.

In its default configuration, the module provides four Type A high-speed counter inputs and outputs plus twelve standard inputs and eight standard outputs.

Each counter provides direct processing of rapid pulse signals up to 80KHz for industrial control applications such as velocity measurement, material handling, and process control.

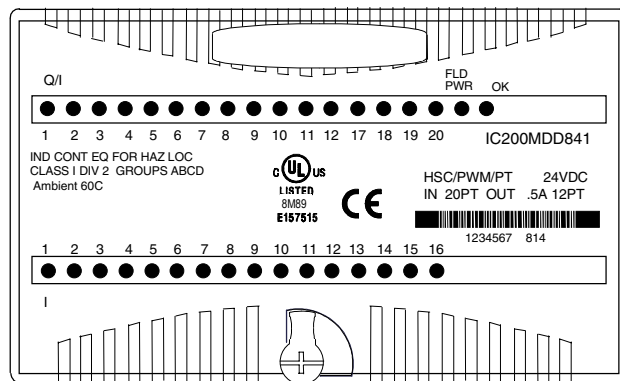

When the module is installed in a VersaMax PLC, its inputs and outputs can be re-configured for a wide variety of applications:

- The high-speed counter inputs can be set up as standard high-speed inputs, as four type A counters, as two type A counters plus one A-quad-B counter, or as one type A-quad-B counter with homing capability.
- Four of the outputs can be configured as pulse-width modulated (PWM), pulse train, ramping pulse train, or high speed counter outputs.

When configured for PWM operation, the frequency of each PWM output is selectable in the range of 22Hz to 2KHz. The % duty cycle of each PWM output can be set from 1 to 100% depending on the frequency of the PWM output. See the PWM Outputs section of this chapter for further details.

When configured as pulse train or ramping pulse train outputs, the sum of frequencies may be up to 5,000 pulses per second. Acceleration and deceleration can be selected from 10 to 1,000,000 p/s².

Power for module operation comes from the backplane. Output devices must be powered by external voltage.

IC200MDD841

**Mixed Module, 24VDC Positive Logic Input 20 Points / Output 12 Point /
(4) High Speed Counter, PWM, or Pulse Train Configurable Points**

LED Indicators

Individual green field-side LEDs show the on/off status of each point

The green FLD PWR LED indicates the presence of field power for the DC outputs.

The OK LED indicates module status.

- On green indicates normal operation.
- Flashing green indicates boot mode or update
- On Amber indicates self diagnostic error
- Off indicates no 3.3V power present.

Configuration Parameters

The module has many features that are selectable by software configuration. These features include:

- Counter type
- Output stop mode
- Channel function
- Counter output enable
- Counter direction
- Counter mode
- Counter Preload/Strobe selection
- Type A counter count input edge
- Counter timebase
- High and low limits
- On and off Presets
- Preload registers
- Pulse-train acceleration
- Pulse-train deceleration

IC200MDD841
Mixed Module, 24VDC Positive Logic Input 20 Points / Output 12 Point /
(4) High Speed Counter, PWM, or Pulse Train Configurable Points**Default Operation**

The default parameters of this module can be used in many applications. The module can be software-configured when it is installed in a VersaMax PLC system, or an I/O Station controlled by a Network Interface Unit that is version 2.0 or above. . In its default mode, the module operates as described below.

Inputs 1 - 8 are one group of high-speed counter inputs. These inputs operate as:

- Four Type A counters.
- Each counter counts upward.
- When a counter reaches its upper limit, it wraps around and starts over.

Inputs 9 - 16 are one group of standard inputs with a common return.

Inputs 17 - 20 are one group of standard inputs with a common return.

Four of the outputs are High-speed Counter outputs. Each High-speed Counter output is dedicated to a corresponding High-speed Counter input.

Eight additional outputs are standard outputs.

The counter outputs use a default ON preset of +32,767, and an OFF preset of 0. If the count reaches the ON preset, the counter's output is turned on. If the count reaches the OFF preset, the counter's output is turned OFF.

When the system is in Stop mode, the High-speed Counter outputs continue to respond to the counter inputs and the standard outputs turn off. Output presets continue to operate as if the CPU/NIU were present, changing state to reflect the counter Accumulators.

In default mode, the module can temporarily change this basic operation in response to up to four commands from the CPU or NIU. These commands can be sent to the module in its regular output data.

- Each counter output can be turned on or off on command.
- Each counter can be reset to 0.
- Each counter's accumulator (current count) register can be loaded with any value from 0 to 32757.
- Each counter's lower and upper limits can be changed.
- Each counter's accumulator can be incremented by a specific amount above its present actual value.
- The count direction can be changed to down (or back to up).
- The timebase for each counter's counts-per-timebase, which measures its rate of counting, can be changed from 1000mS to any value from 10mS to 1000mS.
- Each counter's preload value can be changed.

IC200MDD841

**Mixed Module, 24VDC Positive Logic Input 20 Points / Output 12 Point /
(4) High Speed Counter, PWM, or Pulse Train Configurable Points**

Module Specifications

Module Characteristics	
Points	20 DC inputs & 12 DC outputs
Module ID	FFFF9801
Isolation:	
User I/O to logic (optical) and to frame ground	250VAC continuous, 1500VAC for 1 minute
Point to point	250VAC continuous, 1500VAC for 1 minute
Group to group	
Indicators	One LED per point shows individual point on/off state FLD PWR indicates field power is present OK LED indicates backplane power is present.
Backplane current consumption	3.3V output: 130mA, 5V output: 30mA
External power supply	+24VDC nominal, +18 to +30VDC
Thermal derating	See diagrams
High Speed Channels	
Input frequency (Type A Counter)	80KHz maximum
PWM Output frequency	2 KHz maximum
Pulse Output frequency	5 KHz maximum
Counter Output latency	0.5mS max. between output point updates
Input Characteristics	
Input voltage	+24VDC nominal, 0 to +30VDC
On state voltage	+15.0 to +30.0VDC
Off state voltage	0 to +5.0 VDC
On state current	3.0 to 8.0mA
Off state current	0 to 0.5mA
On/off response time	7.0ms max. (6.25 μ s max. for count inputs and 100 μ s for Preload/Strobe inputs)
Count Input Impedance	6.6kOhms maximum
Count User input current	5.5mA at +24VDC
Standard Input Impedance	9.6kOhms maximum
Standard User input current	4.0mA at +24VDC
Output Characteristics	
Inrush current	2.0A maximum for 100ms
Continuous Load Current	0.5A maximum
Output voltage drop	0.3V maximum
On/off response time	500 μ s, maximum
Protection	no internal fuses
Diagnostics	13 words of status data

IC200MDD841
Mixed Module, 24VDC Positive Logic Input 20 Points / Output 12 Point /
(4) High Speed Counter, PWM, or Pulse Train Configurable Points

Field Wiring

Terminal assignments for the module are shown below.

#	4 Type A Counters	2 Type A & 1 Type B	1 Type B2
A1	Counter 1 Output/PWM/PT1	Output 1/PWM/PT1	Output 1/PWM/PT1
A2	Counter 2 Output/PWM/PT2	Type B Counter 2 out/PWM/PT2	Type B2 Counter 2 out/PWM/PT2
A3	Counter 3 Output/PWM/PT3	Type A Counter Output/PWM/PT3	Output 3/PWM/PT3
A4	Counter 4 Output/PWM/PT4	Type A Counter Output/PWM/PT4	Output 4/PWM/PT4
A5	Output 5		
A6	Output 6		
A7	Output 7		
A8	Output 8		
A9	Output 9		
A10	Output 10		
A11	Output 11		
A12	Output 12		
A13	Input 17		
A14	Input 18		
A15	Input 19		
A16	Input 20		
A17	DC- for outputs 1-12 and inputs 17-20		
A18	DC+ for outputs		
B1	Count1	Type B: Phase 2	Type B2: Phase 2
B2	Preload/Strobe 1	not used	not used
B3	Count2	Type B: Phase 1	Type B2: Phase 1
B4	Preload/Strobe 2	Type B: Preload/Strobe	Type B2: Preload/Strobe
B5	Count3	Type A: Count	not used
B6	Preload/Strobe3	Type A: Preload/Strobe	Home Enable
B7	Count4	Type A: Count	not used
B8	Preload/Strobe 4	Type A: Preload/Strobe	Marker
B9	Input 9		
B10	Input 10		
B11	Input 11		
B12	Input 12		
B13	Input 13		
B14	Input 14		
B15	Input 15		
B16	Input 16		
B17	DC- Common for inputs 1- 8		
B18	DC- Common for inputs 9-16		

IC200MDD841

**Mixed Module, 24VDC Positive Logic Input 20 Points / Output 12 Point /
(4) High Speed Counter, PWM, or Pulse Train Configurable Points**

Input Connections: Inputs are positive logic. Current flows from the input device/switch to the input point.

Inputs 9 - 16 are one group of standard inputs with a common return.

Inputs 17 - 20 are one group of standard inputs with a common return.

Inputs 1 - 8 can be one group of fast inputs with a common return, or high speed counter inputs.

Note: Because of the fast response time of inputs 1-8, shielded cable properly-terminated at earth ground must be used for connecting to this input group in order to meet IEC 1000-4-4.

Output Connections: Outputs are positive logic Current flows from the output to the load. Four of the outputs are high-speed outputs that can be PWM, pulse train, or high speed counter outputs.

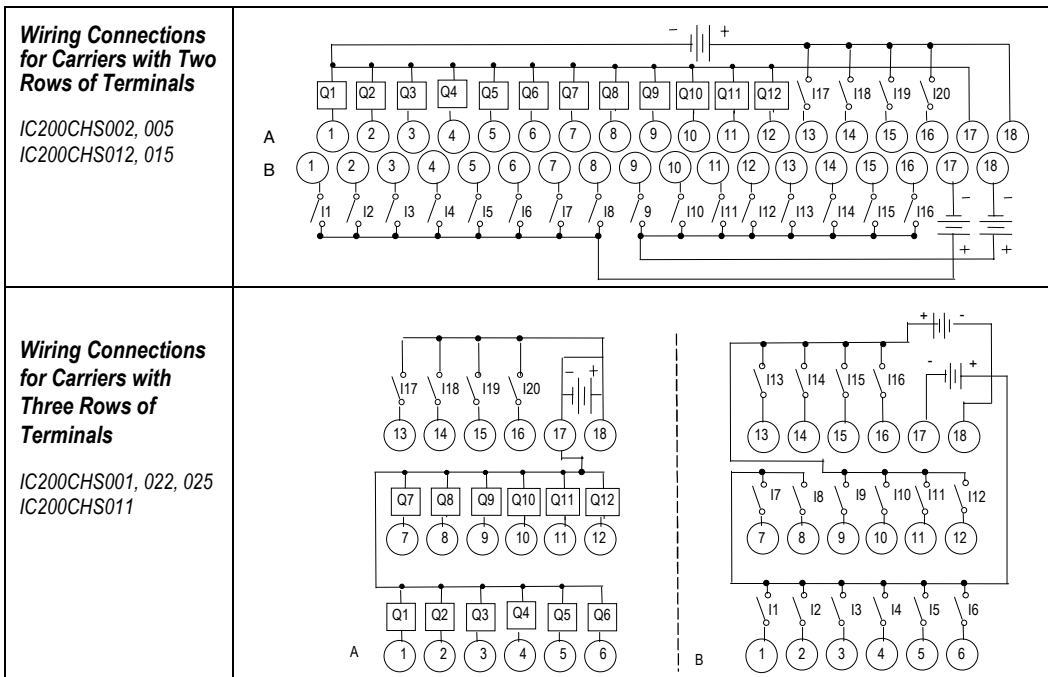

IC200MDD841
Mixed Module, 24VDC Positive Logic Input 20 Points / Output 12 Point /
(4) High Speed Counter, PWM, or Pulse Train Configurable Points

Thermal Derating

The number of points that can be on at the same time depends on the ambient temperature, the external voltage, and the orientation of the module and DIN rail.

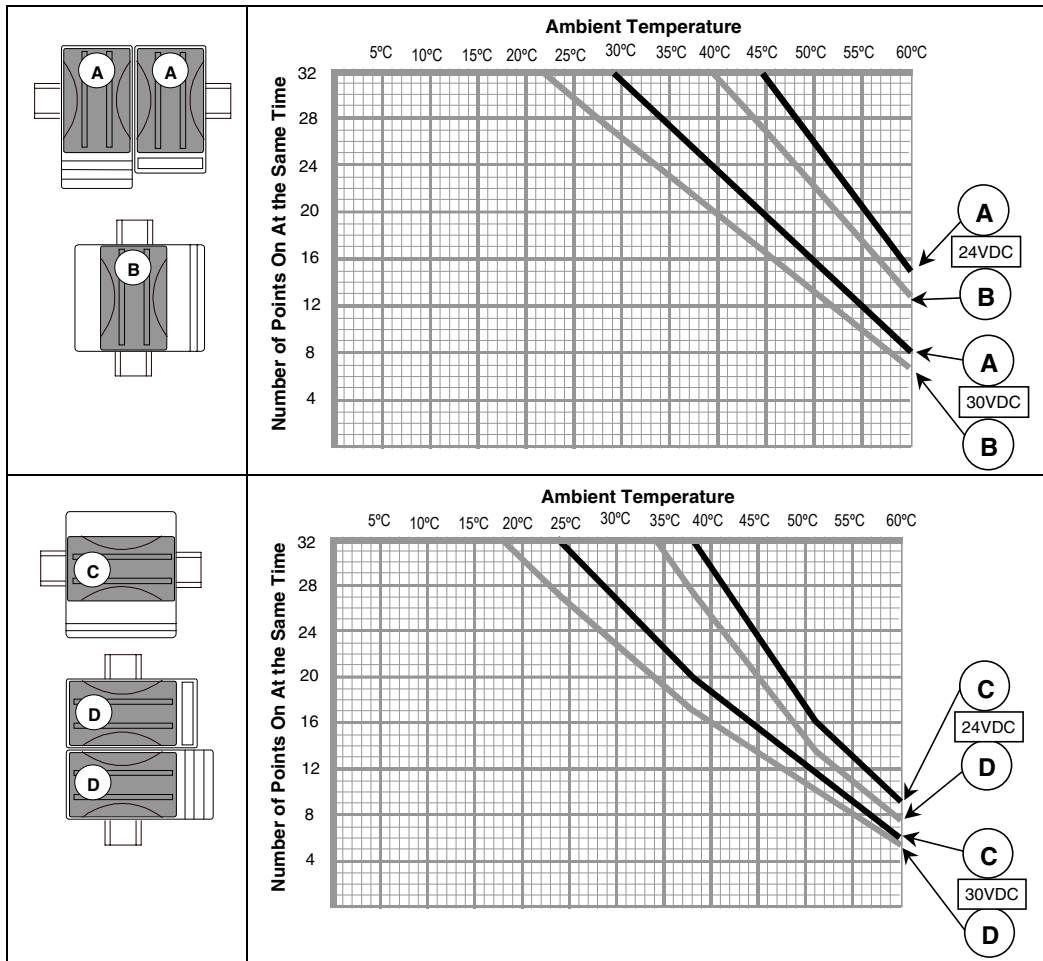

IC200MDD841

**Mixed Module, 24VDC Positive Logic Input 20 Points / Output 12 Point /
(4) High Speed Counter, PWM, or Pulse Train Configurable Points**

Configurable Features

The default parameters of this module can be used in many applications. The module can be software-configured when it is installed in a VersaMax PLC system, or an I/O Station controlled by a Network Interface Unit that provides software configuration.

Parameter	Description	Default	Setting/Value Range
Counter Type	Specifies the counter configuration. If 1 Type B & 2 Type A is selected, counter #1 parameters are used for the Type B counter (except Counter #1 Direction and Counter #1 Count Input Edge parameters) and counter #4 parameters are used for the Type A counter.	4 Type A	4 Type A counters, 1 Type B & 2 Type A, 1 Type B2
Output Stop Mode	Defines what outputs do if the system is in stop mode. Normal means that HSC outputs continue to respond to the counter inputs and standard outputs turn off. Preset outputs, continue to operate as if the CPU/NIU were present, changing state to reflect the counter Accumulators. Force Off means all Preset outputs are turned off and remain off until the CPU/NIU returns to normal operation. Hold Last means Preset outputs retain current levels and do not reflect the counter Accumulators.	Normal	Normal, Force All Outputs Off, Hold
Channel #1/2/3/4 Function	Specifies channel function.	HSC	HSC, PWM, Pulse Train, Standard, Ramp
Counter Output #1/2/3/4 Enable	Specifies if the counter output is enabled. If disabled, the output is used as a standard output.	Enabled	Enabled, Disabled
Counter #1/2/3/4 Direction	(Type A only). Specifies whether count inputs increment or decrement the accumulator.	Up	Up, Down
Counter #1/2/3/4 Mode	Defines whether the counter wraps if the count limit is reached (continuous) or if it stops at the counter limit.	Continuous	Continuous , Single Shot
Counter #1/2/3/4 Preload/Strobe Selection	Specifies the function of the Preload/Strobe Input.	Preload	Preload, Strobe
Counter #1/2/3/4 Count Input Edge for Type A	For Type A counters only, specifies which transition of this input is used. Positive is a low-to-high transition.	Positive	Positive, Negative. Type B and B2 always positive.
Time Base #1/2/3/4	Specifies the timebase for the Counts-per-Timebase register.	1000mS	10mS to 65530mS
High Limit #1/2/3/4	Defines the counter's upper limit. It must be greater than the low limit	+32,767	-32,767 to +32,767
Low Limit #1/2/3/4	Defines the counter's lower limit.	0	-32,768 to +32,766
ON Preset #1/2/3/4	Defines the counter's ON preset. When the count is at or above this value, the HSC output is turned on.	+32,767	-32,768 to +32,767
OFF Preset #1/2/3/4	Defines the counter's OFF preset. When the count is at or above this value, the HSC output is turned off.	0	-32,768 to +32,767
Preload Register #1/2/3/4	This register value is the Preload value for the counter.	0	-32,768 to +32,767
Home Value	The Home Value for the counter.	0	-32,768 to +32,767
Acceleration	Pulse Train acceleration rate from stop to full speed.	1,000,000	10 to 1,000,000
Deceleration	Pulse Train deceleration rate from full speed to stop.	1,000,000	10 to 1,000,000

IC200MDD841

**Mixed Module, 24VDC Positive Logic Input 20 Points / Output 12 Point /
(4) High Speed Counter, PWM, or Pulse Train Configurable Points**

Type A Counters

The Type A counter is one 16-bit counter that can count up or down. Configurable high and low limits set the counter's range.

The counter can either count continuously within its limits, or count to either limit then stop (one-shot mode). In continuous counting, the Accumulator (see below) wraps when the count limit is reached and continues counting. For example, if the Count Direction is up, when the count exceeds the High Limit by 1, the Accumulator value wraps to the Low Limit. In one-shot mode, the counter stops at the limit.

In the example below, the counter has been configured to count on the low to high transition of the Pulse input. The Count signal represents an internal signal that indicates where counting occurs with respect to the pulse input.

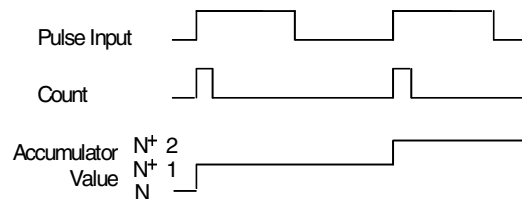

The Type A counter has an Accumulator register, a Counts per Timebase register, a Strobe register, high limit, low limit, and ON/OFF Preset values. These are 16-bit signed numbers. The values selected for the Preload, Accumulator, On Preset, and Off Preset registers must be within the counter limits. The maximum pulse repetition rate of the Preload signal and Strobe must be less than 2kHz, and the duty cycle for both must be such that the signal is high for at least 250 microseconds.

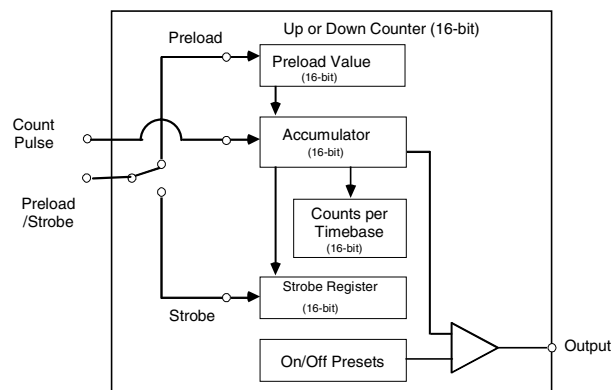

IC200MDD841

**Mixed Module, 24VDC Positive Logic Input 20 Points / Output 12 Point /
(4) High Speed Counter, PWM, or Pulse Train Configurable Points**

The **Count Pulse** input increments or decrements the counter's accumulator. The count input can be configured to be positive or negative edge-sensitive.

The **Preload/Strobe Input** can either preload a value into the accumulator or strobe the accumulator value into a register. Preload/Strobe signals are always positive edge-sensitive.

The **Preload** register contains a predefined value to be transferred to the Accumulator when the Preload/Strobe signal is active. The module sets the Preload flag bit when a Preload occurs. The CPU can clear the flag before the next preload. The Preload input always loads the Accumulator regardless of the state of the Preload flag. The Preload register can be configured to any value within the counter's range.

If **Strobe** is selected, the Accumulator value is placed in the Strobe register when the Preload/Strobe signal is active. The module sets a Strobe flag when a strobe occurs. The PLC or computer can clear this flag before the next strobe. The Strobe input always loads the Strobe register with the Accumulator value regardless of the state of the Strobe flag. Strobe Inputs can be used as Pulse Capture Inputs by using the Strobe status bits as a latch.

The **Accumulator** register contains the current count. It can be set to a value supplied by the PLC or computer. The PLC/computer can also send an adjustment value to the Accumulator register. The adjustment value can be between -128 and +127.

The **Counts-per-Timebase** register contains the number of counts that occurred during the last-completed timebase interval. The number of counts is a 16-bit signed number. The sign indicates up (+) or down (-) counts. The range of the Counts/Timebase register is -32768 and +32767 counts.

The Timebase is a span of time used to measure the rate of counting. For example, the program could monitor the number of counts that occur in 30 seconds. Timebase is configurable in 10mS increments from 10mS to 65530mS. If the timebase is too large, the Counts/Timebase register will lose the overflow values.

The **On/Off Preset** values determine when the counter output is activated or deactivated.

The **Output** can be activated based on configured On and Off Preset values.

IC200MDD841
Mixed Module, 24VDC Positive Logic Input 20 Points / Output 12 Point /
(4) High Speed Counter, PWM, or Pulse Train Configurable Points

Type B Counter

The Type B counter uses two counter input signals for A-Quad-B counting. The phase relationship between the counter inputs (A & B) determines whether the accumulator is incremented or decremented on a transition of either counter input.

The count direction is up if A leads B.

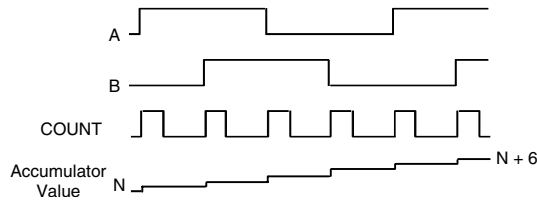

The count direction is down if A lags B.

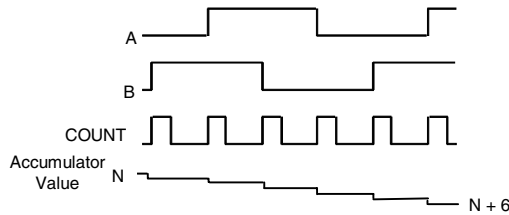

The Type B counter has a Strobe register, a Preload register, a 16-bit Accumulator, and a Counts-per-Timebase register. These operate as described for Type A counters.

The Type B counter can have one output that is activated based on selected On and Off preset values.

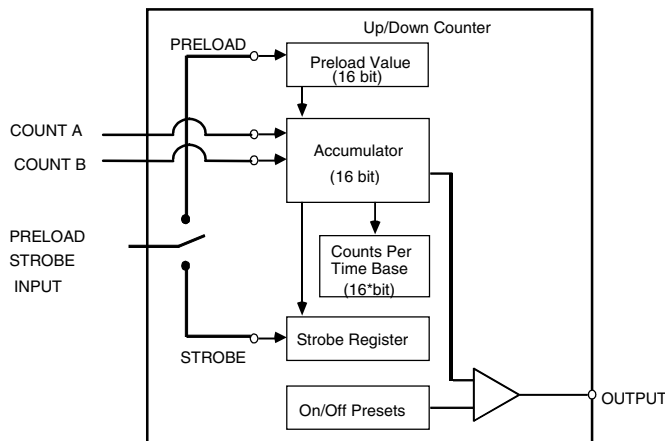

IC200MDD841
Mixed Module, 24VDC Positive Logic Input 20 Points / Output 12 Point / (4) High Speed Counter, PWM, or Pulse Train Configurable Points

Type B2 Counter

The Type B2 counter uses two counter input signals for A-Quad-B counting and two other counter input signals to perform a homing sequence. The operation of this counter is identical to the Type B counter, except for the homing sequence.

The phase relationship between the counter inputs (A & B) determines whether the accumulator is incremented or decremented on a transition of either counter input. The count direction is up if A leads B. The count direction is down if A lags B.

The Type B counter has a Strobe register, a Preload register, a 16-bit Accumulator, and a Counts-per-Timebase register. These operate as described for Type A counters.

The Type B counter can have one output that is activated based on selected On and Off preset values.

Homing Sequence

The Type B2 counter uses two high-speed inputs to perform homing: *Enable Home* and *Marker*. These inputs are normally assigned to Channel 3 Preload/Strobe and Channel 4 Preload/Strobe. Therefore, when the module is configured as a Type B2 counter, no other counters are available.

IC200MDD841
Mixed Module, 24VDC Positive Logic Input 20 Points / Output 12 Point /
(4) High Speed Counter, PWM, or Pulse Train Configurable Points

The homing sequence is performed as follows:

1. Optionally, the *Load Home Value %AQ* command can be used to specify a load value that is different from the one specified in the module configuration.
2. The *Home Start %Q* bit can be set.
3. Upon receiving the new %Q bit, the module clears the %I bit, *Home Sequence Complete*.
4. The module waits for the *Enable Home* signal to transition to a high state. This signal may be taken from a limit or proximity switch located near the home position.
5. The next transition to a high state on the *Marker* signal loads the home value into the counter accumulator, This signal may be taken from a position indicator located on an electromechanical assembly.
6. The module disables the home sequence feature and sets the %I bit *Home Sequence Complete*.

The maximum pulse repetition rate of the marker signal and Enable Home must be less than 2kHz, and the duty cycle for both must be such that the signal is high for at least 250 microseconds.

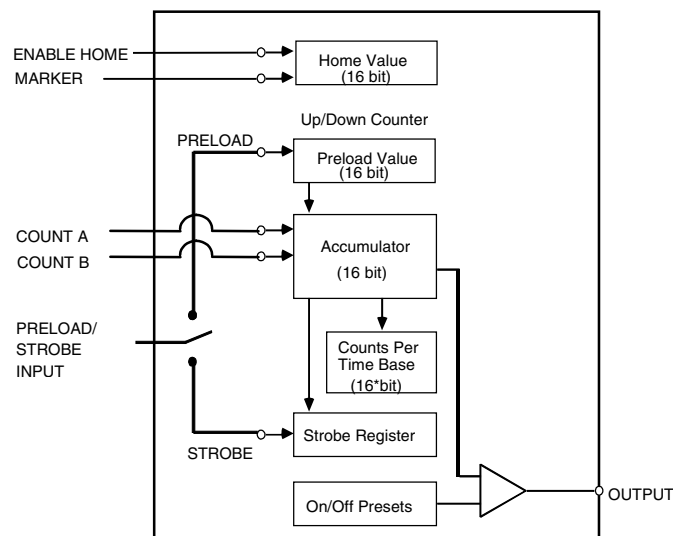

IC200MDD841
Mixed Module, 24VDC Positive Logic Input 20 Points / Output 12 Point /
(4) High Speed Counter, PWM, or Pulse Train Configurable Points

Outputs

Four of the module’s twelve outputs are high speed outputs. These outputs can be configured as high speed counter, PWM, or pulse train outputs.

Counter Outputs

Each counter output has a preset on and off point that must lie between the counter’s high and low limits. The output state indicates when the Accumulator value is between the Preset on and off points. For example, using the Type B counter:

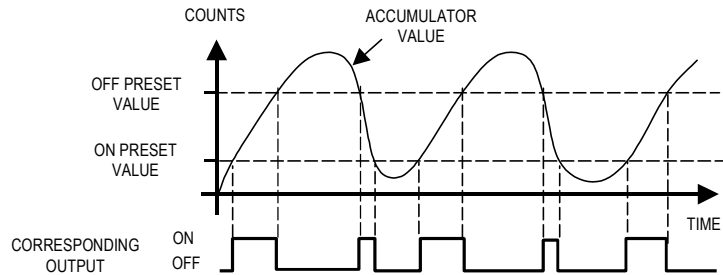

If the output is enabled for the HSC channel being used, the output turns on as shown in the following table:

Preset closest to low limit	Output ON	Output OFF
ON	\geq ON Preset $<$ OFF Preset	$>$ OFF Preset $<$ ON Preset
OFF	$<$ OFF Preset \geq ON Preset	\leq ON Preset \geq OFF Preset

The output can be either on or off when the Accumulator value lies between the Preset points.

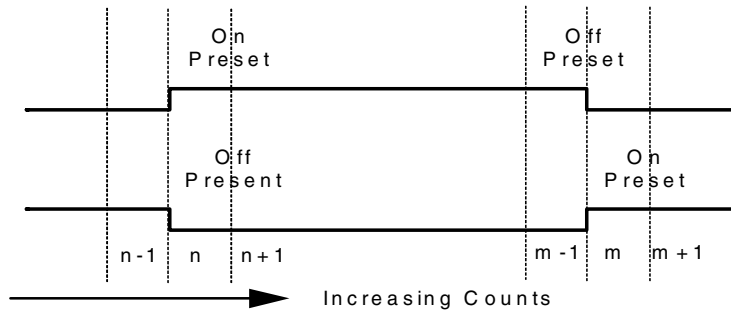

IC200MDD841
Mixed Module, 24VDC Positive Logic Input 20 Points / Output 12 Point /
(4) High Speed Counter, PWM, or Pulse Train Configurable Points

PWM Outputs

PWM outputs can be used to control DC and stepper motors. The parameters of PWM output operation are set up using the module's output data. (See "Module Data"). The frequency of each PWM output can be set in the range of 22Hz to 2KHz. The % Duty Cycle of each PWM output can be set from 1 to 100 depending on the frequency of the PWM output. The graph below plots the relationship between the minimum % Duty Cycle of a PWM output versus the frequency of that PWM output. Note that this relationship is based on a default Optical Isolator Correction factor value of 75 μ S. (See "Optical Isolator Correction Factor" on the next page). For some frequencies, this Optical Isolator Correction factor may be changed to further decrease the minimum duty cycle of that particular frequency.

Minimum % Duty Cycle versus Frequency for a PWM Output

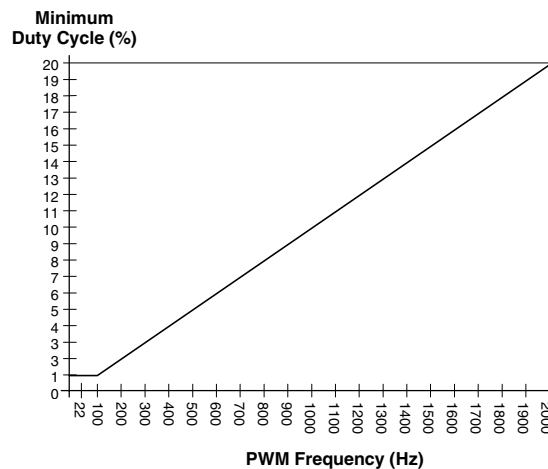

A PWM output is enabled by setting its output enable bit (in the module output data) to ON. The output is disabled by setting its Output Enable bit to OFF.

Both frequency and duty cycle can be changed while the output is enabled.

IC200MDD841
Mixed Module, 24VDC Positive Logic Input 20 Points / Output 12 Point /
(4) High Speed Counter, PWM, or Pulse Train Configurable Points

Pulse Train Outputs

Pulse Train outputs can be used to control stepper motors. Use of an output for this function is set up as part of the module configuration. When configured as Pulse Train outputs, the pulse frequency is specified in the module’s output data, as described later in this section. (See “Module Data”). The range is 1Hz to 5kHz. The module’s output data is also used to set the number of pulses to be emitted.

The Pulse Train starts when its Output Enable bit is ON and its Pulse Train Start bit transitions from Off to ON. When the Pulse Train starts, its Pulse Train Complete status bit is set OFF. When the Pulse Train is complete, the module sets a status bit that can be read by the CPU or computer.

Note: Once a Pulse Train is started, it continues until it has completed or until its Output Enable (%Q) bit goes to 0.

Optical Isolator Correction Factor

The performance of the optical isolators used in the module varies as the temperature changes. This affects the accuracy of the duty cycle for both PWM and Pulse Train outputs. To compensate for this, the module incorporates a user configurable Optical Isolator Correction Factor. The default Correction Factor is 75µS in duration. The Correction Factor can be changed within the range 0 to 200µS by sending the new value in the module’s output data. An example is illustrated below. In the diagram, *T*0 is the OFF

Time, which is $\frac{1}{2f} + Correction$, where *f* is the pulse frequency.

$T_1 = \frac{1}{2f}$, *T*2 = Optical Isolator Delay, and *T*1+*T*2 = ON Time.

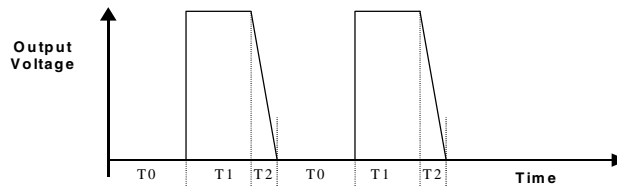

IC200MDD841

**Mixed Module, 24VDC Positive Logic Input 20 Points / Output 12 Point /
(4) High Speed Counter, PWM, or Pulse Train Configurable Points**

Ramp Outputs

When an output's function is selected to be Ramp (in the module configuration), acceleration and deceleration factors are applied to the Pulse-Train output.

Acceleration and deceleration factors can be specified using Data Commands, as explained later in this section. Both acceleration and deceleration can be selected from the range of 10 p/s^2 to $1,000,000 \text{ p/s}^2$. The default for both is $1,000,000$. Acceleration and deceleration do not need to be the same. Appropriate values depend on the application and the capability of the stepper motor being driven by the module.

A Ramp function begins when the module detects that the channel's Enable Output bit (discrete output bit 21-24, see "Module Data") is On and an Off-to-On transition has occurred on the channel's Start Pulse Train bit (discrete output bit 25-28). At that point, the Pulse Train begins and the channel's Pulse Train Complete bit (discrete input bit 33-36) is set Off. The module outputs the specified number of pulses, in varying pulse widths, to produce a velocity profile similar to the one shown below. After the last pulse is completed, the module sets the channel's Pulse Train Complete bit Off and begins monitoring the channel's Start Pulse Train bit for another Off-to-On transition.

The Ramp feature results in a Pulse-Train profile similar to the example shown below.

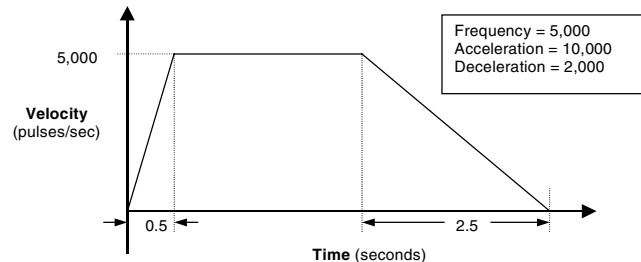

Once a Ramp function has started, it continues until all of its pulses have been generated or its Output Enable bit (discrete output bit 21-24) changes from On to Off.

A Pulse Train output can be terminated before the requested number of pulses have been completed by setting its Output Enable bit (discrete output bit 21-24) to Off. If the Enable Output bit transitions from On to Off, the module will either stop the Pulse Train immediately or transition the Ramp output to its deceleration phase—depending on the channel's configuration. If deceleration is configured, the module will output a number of pulses based on: (1) the configured deceleration and (2) the velocity at the time the Enable Output bit goes Off. When the last pulse is completed, the module will set the channel's Pulse Train Complete bit (discrete input bit 33-36) to On.

IC200MDD841

**Mixed Module, 24VDC Positive Logic Input 20 Points / Output 12 Point /
(4) High Speed Counter, PWM, or Pulse Train Configurable Points**

Stop Ramp with Deceleration

The graphics below show how stopping a Ramp early affects the Ramp output if the output is configured for deceleration. The example on the left shows what happens when the Enable Bit is set OFF during the “at velocity” part of the output. The righthand example shows the impact when the Enable Bit is set OFF during the “ramp up” part of the output.

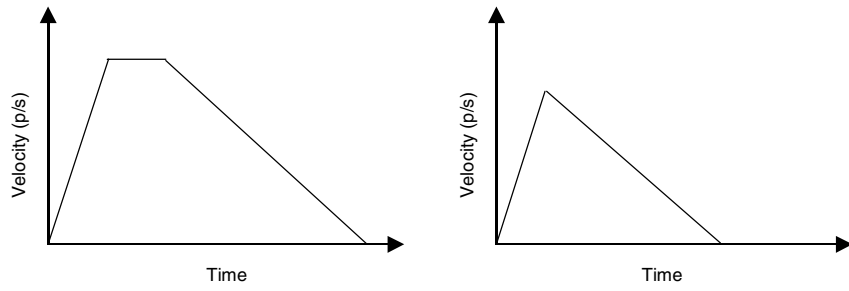

Note that if the Ramp output is already decelerating when the Enable Output bit transitions from On to Off, there is no change to the operation of the Pulse Train output.

Configuration

When the module powers up or receives a new configuration, it automatically sets up all Ramp channels to decelerate when the Output Enable bit goes OFF. If a Ramp output should stop immediately, the channel can be reconfigured with a Data command or a COMREQ. The data block is the same for both:

	MSB	LSB
Command word	0n	3B
Data word (LSW)	dddd	
Data word (MSW)	Always zero	

- “0n” is the channel number from 1 to 4.
- “3B” is the command (in hexadecimal): Load Stop Mode
- “dddd” is the Stop Mode parameter. It can be “1” for Decelerate and “2” for Stop Immediately. If any other value is specified, error code 13 (hex) is placed in the Module Status Word.

IC200MDD841
Mixed Module, 24VDC Positive Logic Input 20 Points / Output 12 Point /
(4) High Speed Counter, PWM, or Pulse Train Configurable Points

Output Defaults

If the CPU or NIU stops communicating with the High Speed Counter module, so that the module no longer receives fresh output data, counter operation continues normally.

Normal (default setting) The inputs continue to be processed by the module. The outputs continue to operate as if the CPU/NIU were present, changing state to reflect the counter Accumulators.

Preset outputs can also be configured to operate in the following modes if the CPU stops providing output data:

Force Off All Preset outputs are turned off and remain off until the CPU returns to normal operation.

Hold Last The Preset outputs retain current levels and do not reflect the counter Accumulators.

IC200MDD841

**Mixed Module, 24VDC Positive Logic Input 20 Points / Output 12 Point /
(4) High Speed Counter, PWM, or Pulse Train Configurable Points**

Module Data

The module provides 40 bits of bit input data and 13 words of word input data:

Bit Inputs (%I)	1 - 20	Standard Inputs #1 to #20
	21 - 24	Strobe Status #1 to 4
	25 - 28	Preload Status #1 to 4
	29 - 32	HSC Output Status #1 to 4
	33 - 36	Pulse Train Complete #1 to 4
	37	Home Complete
	38 - 39	reserved
	40	Status code present in Word Input 1
Word Inputs (%AI)	1	Module Status Code . Status Codes. See the section Command Word Error Definitions at the end of this chapter.
	2 - 5	Counts-per-Timebase #1 to 4.
	6	Accumulator register #1.
	7	Strobe register #1.
	8	Accumulator register #2.
	9	Strobe register #2.
	10	Accumulator register #3.
	11	Strobe register #3.
	12	Accumulator register #4.
	13	Strobe register #4.

IC200MDD841
Mixed Module, 24VDC Positive Logic Input 20 Points / Output 12 Point /
(4) High Speed Counter, PWM, or Pulse Train Configurable Points

The High Speed Counter module receives 32 bits of bit output data and 20 words of word output data. The output bits and output words 1 through 8 are the basic module outputs.

Output words 9-20 have a special function. They can be used to send output commands to the module that temporarily change module operation. Use of these output commands is described beginning on the next page.

Bit	1 - 12	Standard Outputs #1 to #12	
	Outputs	13 - 16	Clear Strobe Status Bit #1 to 4
		17 - 20	Clear Preload Status Bit #1 to 4
	(%Q)	21 - 24	Enable HSC/PWM/Pulse Train Output #1 to 4
		25 - 28	Start Pulse Train #1 to 4
		29	Home Start
		30 - 31	reserved
	32	Clear Module Status bit	
Word	1	PWM/Pulse Train Frequency #1. PWM output frequency range: 22Hz to 2KHz. Pulse Train pulse frequency range: 1Hz to 5kHz.	
Outputs	2	PWM Duty Cycle/Number of Pulses #1. PWM duty cycle range: see graph in PWM Outputs section	
	(%AQ)	3	PWM/Pulse Train Frequency #2.
4		PWM Duty Cycle/Number of Pulses #2.	
5		PWM/Pulse Train Frequency #3.	
6		PWM Duty Cycle/Number of Pulses #3.	
7		PWM/Pulse Train Frequency #4.	
8		PWM Duty Cycle/Number of Pulses #4.	
9 - 11		Command word 1, words 1 to 3. See next page.	
12-14		Command word 2, words 1 to 3	
15-17	Command word 3, words 1 to 3		
18-20	Command word 4, words 1 to 3		

IC200MDD841

**Mixed Module, 24VDC Positive Logic Input 20 Points / Output 12 Point /
(4) High Speed Counter, PWM, or Pulse Train Configurable Points**

Data Commands

Temporary operating changes can be made using Data Commands. Data Commands can be sent to the module as part of its analog (AQ) data. A VersaMax PLC CPU can also send Data Commands using the COMREQ function.

Data Command Formats

A Data Command uses 3 words of memory. The contents of these 3 words are:

	MSB	LSB	
command word	0n	cc	where: n=counter 1-4 cc=subcommand code dd=data type
data word (LSW)	dd	dd	
data word (MSW)	dd	dd	

In the total analog output (AQ) data used by the module, there is room for 4 of these data commands, which are arranged as follows:

Output Words 9-11	Command 1
Output Words 12-14	Command 2
Output Words 15-17	Command 3
Output Words 18-20	Command 4

There is no limit to the length of time a command can be present in the output words. The module acts on a command only when it detects a change in the command words.

IC200MDD841
Mixed Module, 24VDC Positive Logic Input 20 Points / Output 12 Point /
(4) High Speed Counter, PWM, or Pulse Train Configurable Points

Data Command Definitions

Data Commands can be used to temporarily change the counter parameters listed below. These changes are lost when the module is powered down and when a new configuration is stored from the programmer. The bytes in the command word are treated as independent bytes: a counter ID byte and a command code byte. Command words can be entered in hexadecimal or decimal format. In the table, for Type A, n = Counter #1–4. For Type B, n = Counter #2 (only counter 2 is B-type)

Command Word (hex)	Command	Description
0n01	Load Accumulator	Loads any value within a counter's limits directly into the Accumulator. If a count is received at the same time, the count is lost. Example: To set Counter 1 to 1234H, load COMREQ command registers with: Command word: 0101 LS data word: 1234
0n02 0n03	Load High Limit Load Low Limit	Sets the High and Low limit to any value in the counter range. Move the Low Limit first when shifting down or the High Limit first when shifting up. Loading limits in the wrong order can cause an error. The command is successful if all parameters are within the new range. Example: To change the upper limit of counter 1 to 10000 (2710H), load registers with: Command word: 0102 LS data word: 2710
0n04	Load Accumulator Increment	Offsets a counter Accumulator by up to +127 or –128 counts. Only the LSB data is used with this command. This can be done at any time, even while the counter is counting at maximum rate. However, if a count is received at the same time the CPU updates the Accumulator value, the count is lost. If the offset causes the counter to exceed its limits, this parameter is rejected. Example: To offset counter 1 by –7 counts, load: Command word: 0104 LS data word: 00F9
0n05	Set Counter Direction	(Type A only) Changes the count direction of a type A counter. Only the LSB of the first data word is used for this command (00 = up, 01 = down). Example: To set the direction of counter 4 to down, load: Command word: 0405 LS data word: 0001
0n06	Load Timebase	Changes the time interval used for the counts/timebase word data. The range is 10 to 1000mS in 10mS intervals. Example: To change the timebase for counter 1 to 600 ms (258H), load: Command word: 0106 LS data word: 0258
0208	Load Home Value	Changes the home value for the Type B2 counter.
0n0B	Load ON Preset	Sets up the output turn on points within the counter range. There is one output associated with each counter. Example: To set counter 1 output to turn on at 5000 (1388H) counts, load: Command Code: 010B LS data word: 1388

IC200MDD841

**Mixed Module, 24VDC Positive Logic Input 20 Points / Output 12 Point /
(4) High Speed Counter, PWM, or Pulse Train Configurable Points**

Command Word (hex)	Command	Description
0n15	Load OFF Preset	<p>Sets up the output turn off points within the counter range. There is one output associated with each counter.</p> <p>Example: To set counter 1 output to turn off at 12000 (2EE0H) counts, load: Command Code: 0115 LS data word: 2EE0</p>
0n1F	Load Preload	<p>Changes the count value loaded into the counter Accumulator when the Preload input is activated.</p> <p>Example: To make counter 1 start at 2500 (09C4H) counts at its preload signal, load: Command word: 011F LS data word: 09C4</p>
0n3B	Load Stop Mode (or Resume Decelerate Mode)	<p>Changes a Pulse Train output's deceleration to stop the Ramp immediately when the Output Enable bit goes Off. The Ramp function must be enabled.</p> <p>Example: to set up a Pulse Train output for Stop Ramp (0002) operation on ch.1: Command word: 013B LS data word: 0002</p> <p>The same command can be used to reset the output to Decelerate mode (the default) by entering the value 0001 in the LS data word.</p> <p>Example: reset the same Pulse Train output to Decelerate (0001) operation: Command word: 013B LS data word: 0001</p>
0n3C	Load Acceleration	<p>Changes a Pulse Train output's acceleration. The Ramp function must be enabled. Both acceleration and deceleration can be selected from the range of 10 p/s² to 1,000,000 p/s². The default for both is 1,000,000.</p> <p>In the acceleration and deceleration commands, the data value is a 32-bit number. These are the ONLY Data Commands that should have any value other than 0 in the MS data word.</p> <p>Example: to change the acceleration rate of Pulse Train output 1 to 200,000 (30D40H), load: Command word: 013C LS data word: 0D40 MS data word: 0003</p>
0n3D	Load Deceleration	<p>Changes a Pulse Train output's deceleration. The Ramp function must be enabled.</p> <p>Example: to change the deceleration rate of Pulse Train output 1 to 2,000 (700H), load: Command word: 013D LS data word: 700</p>
0n3E	Load Correction	<p>Sets the change (in microseconds) that should be applied to the duty cycle of a Pulse Train output to compensate for the slow turn-off time of the optical isolator circuit (default to 75µs). The range is 0 to 200 microseconds.</p> <p>Example: to change the duty cycle of Pulse Train output 1 to 100 (64H), load: Command word: 013E LS data word: 64</p>

IC200MDD841
Mixed Module, 24VDC Positive Logic Input 20 Points / Output 12 Point /
(4) High Speed Counter, PWM, or Pulse Train Configurable Points

Using the COMREQ Function to Send Data Commands

The VersaMax PLC CPU can use the COMREQ function to send Data Commands to the High Speed Counter module. These commands are all 6 bytes in length. The command data must be placed in the correct order (in a *command block*) in CPU memory before the command is executed. Program logic should be set up to assure that the command is sent to the module once, not repeatedly. This function is effective only on counters that are enabled.

Command Block

The format for Data Commands is as follows:

	MSB	LSB	
command word	0n	cc	where: n=counter 1-4 cc=subcommand code dd=data type
data word (LSW)	dd	dd	
data word (MSW)	dd	dd	

The command block used to send Data Commands is composed of 10 words as shown below. All values are hexadecimal unless otherwise indicated. Note that if the command block is not set up correctly, unexpected operation may occur. The command block can be placed in any word-oriented area of memory that is not reserved.

Location	Data	Description
%R0001	0004	Should be 0004
%R0002	0000	Reserved (must be zero)
%R0003	nnnn	Status Data type (0008 = R, 000A=AI, 000C=AQ, 0010=I, 0012=Q)
%R0004	nnnn	Start location of COMREQ Status word
%R0005	0000	Reserved (must be zero)
%R0006	0000	Reserved (must be zero)
%R0007	0003	HSC application request (always 3)
%R0008	nnnn	Command word
%R0009	nnnn	LS data word
%R0010	nnnn	MS data word

IC200MDD841
Mixed Module, 24VDC Positive Logic Input 20 Points / Output 12 Point /
(4) High Speed Counter, PWM, or Pulse Train Configurable Points

Command Word Error Responses

If the module receives an invalid command parameter in a Command Word, it returns the following information in the first word of its word input (AI) data:

Error Code(hex)	Commands	Description
0	All (Unless COMREQ)	No Error
0x11	N/A	Unknown command word
0x12	Load High/Low Limit	Invalid Low or High limit value
0x13	Load Stop Mode/Reset Decelerate Mode	Invalid value. Must be 1 (decelerate) or 2 (stop).
0x14	Load Acceleration	Acceleration too low. Must be ≥ 10 .
0x15	Load Acceleration	Acceleration too high. Must be $\leq 1,000,000$
0x16	Load Deceleration	Deceleration too low. Must be ≥ 10 .
0x17	Load Deceleration	Deceleration too high. Must be $\leq 1,000,000$
0x21	All	Invalid Channel
0x22	Load High/Low Limit	New limit places Preload value out of range
0x52	Load High/Low Limit	New limit places On Preset out of range
0x62	Load High/Low Limit	New limit places Off Preset out of range
0x72	Load High/Low Limit	New limit places Accumulator value out of range
0x81	Load Accumulator, Load Accumulator Increment	Accumulator value is out of range
0x91	Load Preload	Preload value is out of range
0xC1	Load On Preset	On Preset value is out of range
0xD1	Load Off Preset	Off Preset value is out of range
0xE1	Set Counter Direction	Invalid direction value
0xF0	Load Timebase	Invalid Timebase
0xF1	Load Home Value	Home Value is out of range

The format for the Module Status Word is:

MSB		LSB
Source of the command: 1=AI data, Command Word 1 2= AI data, Command Word 2 3= AI data, Command Word 3 4= AI data, Command Word 4 5=COMREQ	Channel (1-4): The module channel the Command Word data was intended for.	Error Code, listed above

If a COMREQ was used, the error code alone is also returned in the COMREQ Status Word. A COMREQ returns a 1 in the case of no error.

Chapter
14

Temperature-Sensing Modules

This chapter describes the following temperature-sensing VersaMax analog input modules:

- IC200ALG620 Analog Input, 16 Bit RTD, 4 Channels
- IC200ALG630 Analog Input, 16 Bit Thermocouple, 7 Channels

IC200ALG620 Analog Input, 16 Bit RTD, 4 Channels

The VersaMax Analog Input RTD Module (IC200ALG620) is an intelligent module that accepts input signals from up to 4 RTD input devices and provides input data with 16 bits of resolution.

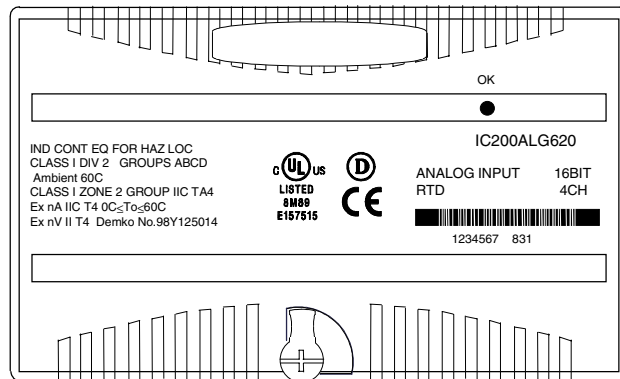

No external power supply is required for this module. The excitation current for the RTDs is provided by the module, which automatically matches the excitation current to each configured RTD type.

The RTD Analog Input Module accepts inputs from 4 independent 3-wire and/or 4-wire platinum, nickel, nickel/iron, or copper RTDs.

Module features include:

- Selectable resistance measurements in tenths of ohms, tenths of degrees Fahrenheit, or tenths of degrees Celsius
- Individual channel configuration
- Selectable resistance ranges: 0 – 500 ohms and 0 – 3000 ohms
- Selectable RTD input as resistance or temperature (Celsius or Fahrenheit)
- Reports high/low, underrange/overrange, open wire and input short alarms.
- Two data acquisition rates based on 50 Hz and 60 Hz line frequencies
- Configurable channel activation

IC200ALG620 Analog Input, 16 Bit RTD, 4 Channels

LED Indicators

The green FLD PWR LED indicates the presence of both backplane power and field power for the analog field-side circuits. The absence of either backplane or field power turns off the FLD PWR LED.

The OK LED indicates module status:

- On green indicates normal operation
- Flashing green indicates boot mode or update
- Flashing amber indicates self-diagnostic error
- Off indicates no 3.3V backplane power

Diagnostics

The module reports over/under range, open wire, non-volatile memory storage, high/low alarm, and input short diagnostics to the I/O Fault Table.

Calibration

The module automatically performs A/D calibration at powerup. Automatic calibration is then repeated periodically to compensate for changes in the ambient temperature.

Host Interface

The RTD Input module provides 4 words of analog input data.

Compatibility

This module is compatible with:

- VersaMax PLC CPU version IC200CPU001-BC firmware version 1.20 or later.
- Genius NIU version IC200GBI001-AB Firmware version 1.10 or later
- Profibus NIU version IC200PBI001-BB firmware version 1.10 or later
- DeviceNet NIU version IC200DBI001-AA Firmware version 1.10 or later

IC200ALG620
Analog Input, 16 Bit RTD, 4 Channels

Module Specifications

Module Characteristics	
Channels	Four 3-wire and/or 4-wire RTDs
Module ID	
Isolation:	
User input to logic (optical) and to frame ground	250VAC continuous; 1500VAC for 1 minute
Group to group	Not applicable
Channel to channel	50VDC
LED indicators	OK LED: green indicates backplane power is present. Amber indicates module fault.
Backplane current consumption	5V output: 125mA maximum. 3.3V output: 125mA
External power supply	None
Thermal derating	None
Configuration parameters	See configuration table
Diagnostics	Over/under range, open wire, non-volatile memory storage fault, wiring fault, high/low alarm, input short
Update rate	60 Hz: approximately 210 milliseconds per channel 50 Hz: approximately 230 milliseconds per channel
Normal mode rejection	60dB, at 50/60 Hz, 100% span
Common mode rejection	120 dB at 50/60Hz, 100 ohm imbalance
Common mode voltage	3V maximum
Normal mode voltage	5V maximum
Digital Resolution	15 bits plus sign
Operating temperature range	0 to 60 Degrees C ambient
Input Characteristics	
RTD types	25, 100, and 1000 ohm platinum 10, 50, and 100 ohm copper 100 and 120 ohm nickel 604 ohms nickel/iron
Resistance ranges	0 to 500 ohms 0 to 3000 ohms
Accuracy, at 25° C	
on voltage measurement:	+/-0.15% on resistance measurement
on temperature measurement:	+/-0.15% on RTD (temperature) measurement
Temperature sensitivity (0° to 60°C)	+/-0.004% of reading, +/-1.5µV per °C referred to input
Maximum lead resistance	5 ohms per lead

IC200ALG620
Analog Input, 16 Bit RTD, 4 Channels

Field Wiring

Terminal	Connection	Terminal	Connection
A1	Source 1	B1	No connection
A2	In (+) 1	B2	Shield Termination Point
A3	In (-) 1	B3	No connection
A4	Return 1	B4	Shield Termination Point
A5	Source 2	B5	No connection
A6	In (+) 2	B6	Shield Termination Point
A7	In (-) 2	B7	No connection
A8	Return 2	B8	Shield Termination Point
A9	Source 3	B9	No connection
A10	In (+) 3	B10	Shield Termination Point
A11	In (-) 3	B11	No connection
A12	Return 3	B12	Shield Termination Point
A13	Source 4	B13	No connection
A14	In (+) 4	B14	Shield Termination Point
A15	In (-) 4	B15	No connection
A16	Return 4	B16	No connection
A17	No connection	B17	No connection
A18	No connection	B18	No connection

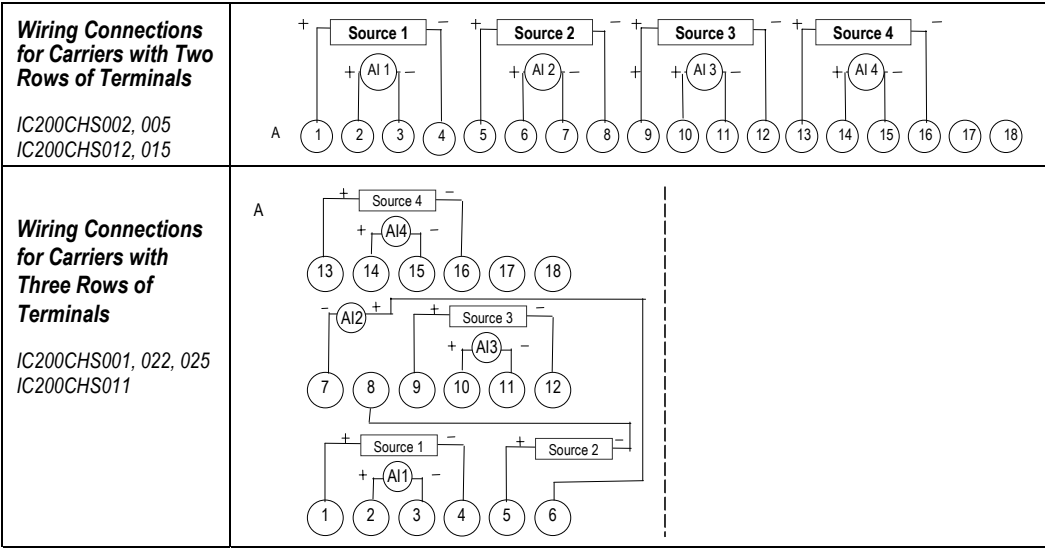

IC200ALG620 Analog Input, 16 Bit RTD, 4 Channels

Wiring Examples

The following illustration shows connections for 3-wire and 4-wire RTDs.

No loop power is required for this module. The excitation current for the RTDs is provided by the module, which automatically matches the excitation current to each configured RTD type.

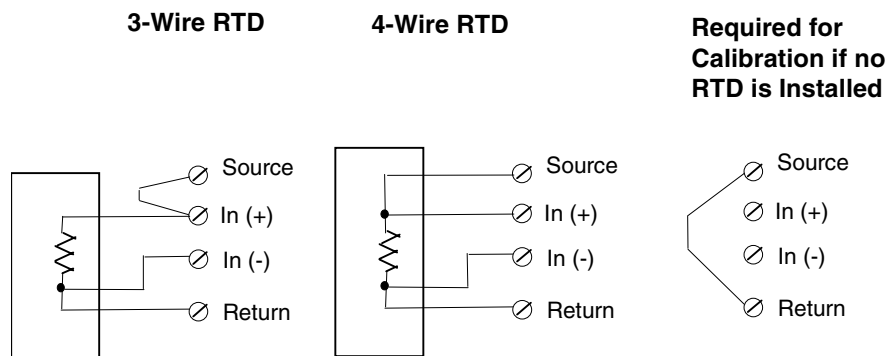

Cable Shield Connections

If possible, the cable should be grounded at the source device. If that is not possible, the cable shield must be grounded at the source device. If that is not possible, the cable shield must be grounded at the I/O module. This can be done using an Auxiliary I/O Terminal (IC200TBM001, 002, or 005).

If the module is installed on a Terminal-style I/O Carrier (IC200CHS001, 002, or 005), shield connections can be made on an Auxiliary I/O Terminal that is attached to the I/O carrier.

If the module is installed on a Compact Terminal-style I/O Carrier (IC200CHS022, 025), shield connections can be made on an Auxiliary I/O Terminal that is mounted near the I/O carrier. Be sure to ground the Auxiliary I/O Terminal Strip if you plan to use it for this purpose.

If the module is installed on a Connector-style I/O Carrier (IC200CHS003), the cable shield can be connected directly to an Interposing Terminal (IC200CHS011, 012, 015). Be sure to ground the Interposing Terminal. It is recommended to use a shielded interposing cable as well between the Interposing Terminal and the Connector Base. A custom shielded cable can be made using the Connector kit (IC200ACC302). In addition, a custom shield braid can be wrapped around standard Interposing Cables (IC200CBL105, 110, 120, 230). If this approach is used be sure to ground the braid.

IC200ALG620
Analog Input, 16 Bit RTD, 4 Channels

Configurable Parameters

The default parameters of the RTD Input module can be used in many applications. The module can be software-configured when it is installed in a VersaMax PLC system, or an I/O Station controlled by a Network Interface Unit that is version 2.0 or above.

Module Parameter	Description	Default	Choices
Analog Input Data Length	Word length of the module's analog input data.	4	0–4
Analog Input Data Reference	Starting offset for the module's analog input data.		user selectable
Line Frequency	Specifies the line frequency.	60 Hz	50 Hz, 60 Hz
Channel Active	Specifies if the channel should return data and alarms. If a channel is "inactive" space is still allocated for it.	Active	Inactive (off), Active (on)
Units	The conversion type for each RTD.	Deg C	tenths of ohms, tenths of degrees C, or tenths of degrees F
RTD Type	The type of RTD used for each channel.	100 PT 385	10 PT, 25 PT, 25.5 PT 392, 100 PT 385, 100 PT 3902, 100 PT 392, 100 PT 3923, 100 PT 3916, 1K PT 375, 10 CU, 10 CU 427, 50 CU 427, 100 CU 427, 100 NI, 100 NI 618, 120 NI 672 604 NI/FE 518, 1K NI/FE 527, 500 Ohm, 3000 Ohm
Wire Type	The type of field wiring for each RTD.	3 Wire	3 Wire, 4 Wire
Alarm Low	The low alarm limit for the channel, in engineering units.	–200	–32,768 to +32,767
Alarm High	The high alarm limit for the channel, in engineering units.	800	–32,768 to +32,767
Nominal Resistance	An optional resistance adjustment, in tenths of ohms.	0	0 to 3276.7
Channel Default Input	Specifies analog input returned upon error (including open circuit errors).	0	± 3276.7

IC200ALG620
Analog Input, 16 Bit RTD, 4 Channels

Module Features

Channel Active

Each channel can be configured as either active or inactive.

If a channel is inactive, it is not scanned and a value of 0 is returned by the module.

Input Units

Inputs can be measured as tenths of Ohms, tenths of degrees C, or tenths of degrees F. The default is tenths of degrees C. The measurable ranges for each type of input units are shown below.

Units Selected	Integer Ranges	Engineering Units Ranges
Tenths of Degrees	-32767 to +32767	-3276.7° to +3276.7°
Tenths of Ohms	0 to 65535	0 Ohms to 6553.5 Ohms

Low Alarm Limit and High Alarm Limit

Each input channel can have a low alarm limit and a high alarm limit. If an input reaches one of its limits, the module reports the actual value and reports an alarm fault in the I/O Fault Table. Alarms do not stop the process or change the value of the input.

Alarm limits can be set anywhere over the dynamic range of the signal. The range for each is -32,768 to +32,767. The high alarm limit must be greater than the low alarm limit. If alarm reporting is not wanted, alarm limits can be set beyond the dynamic range of the signal so they will never be activated.

IC200ALG620
Analog Input, 16 Bit RTD, 4 Channels

Input Selection to Include RTD Type

Each input channel can have a different RTD type. The module supports the RTD types listed below. If the actual RTD resistance does not match a defined type, an adjustment factor can be configured in tenths of ohms.

Selection	Comments	Selection	Comments
25.5 PT 392	25.5 Ohm Platinum, $\alpha = .00392$ at 0°C Lab Std	9.035 CU 427	9.035 Ohm Copper, at 25°C, $\alpha = .00427$
100 PT 385	100 Ohm Platinum, DIN43760, $\alpha = .00385$	50 CU 427	50 Ohm Copper, $\alpha = .00427$
100 PT 3902	100 Ohm Platinum, $\alpha = .003902$	100 CU 427	100 Ohm Copper, $\alpha = .00427$
100 PT 392	100 Ohm Platinum, $\alpha = .00392$ IPTS-68	100 NI 618	100 Ohm Nickel At 0°C, DIN43760, $\alpha = .00618$
100 PT 3923	98.13 Ohm Platinum, $\alpha = .003923$	120 NI 672	120 Ohm Nickel, at 0°C, $\alpha = .00672$
100 PT 3916	100 Ohm Platinum, $\alpha = .003916$	604 NI/FE 518	604 Ohm Nickel/Iron, at 0°C, $\alpha = .00518$
1K PT 375	1 KOhm Platinum, $\alpha = .00375$	500 OHM	Select UNITS of 1/10 Ohms
10 CU	10 Ohm Copper, at 25°C, IPTS-68	3000 OHM	Select UNITS of 1/10 Ohms

RTD Limits

The table below lists the ohms and temperature limits for different RTD types.

RTD Type	Low Ω Limit	High Ω Limit	Low Temp. °C	High Temp. °C
10 Ohm Copper @ 25°C	6.13600	14.8200	-75.00	150.00
10 Ohm Platinum @ 25°C	7.02000	37.2599	-70.00	1000.00
1 KOhm Platinum, $\alpha = .00375$	199.4880	2754.620	-200.00	500.00
100 Ohm Platinum $\alpha = .00385$	27.01	389.936	-180.0	850.0
100 Ohm Platinum, $\alpha = .003902$	93.5400	135.000	-17.7777	99.9999
100 Ohm Platinum IPTS68 (PA)	26.5	327.744	-200.0	630.0
100 Ohm Platinum SAMA-RC21-4 (PC)	26.5	311.874	-200.0	600.0
100 Ohm Platinum JISC-1604-'81	26.5	323.780	-200.0	620.0
25.5 Ohm Platinum Lab Std (PJ)	4.50	83.575	-200.0	630.0
9.035 Ohm Copper (CA)	6.05	16.400	-100.0	260.0
50 Ohm Copper (CB/2)	28.379	105.787	-100.0	260.0
100 Ohm Copper (CB)	56.757	211.574	-100.0	260.0
100 Ohm Nickel (NB)	69.520	223.221	-60.0	180.0
120 Ohm Nickel (NA)	66.600	380.310	-80.0	260.0
604 Ohm Nickel/Iron (FA)	372.789	1318.722	-100.0	204.0

IC200ALG630 Analog Input, 16 Bit Thermocouple, 7 Channels

The Thermocouple Analog Input Module (IC200ALG630) is an intelligent module that accepts 7 independent thermocouple or millivolt inputs.

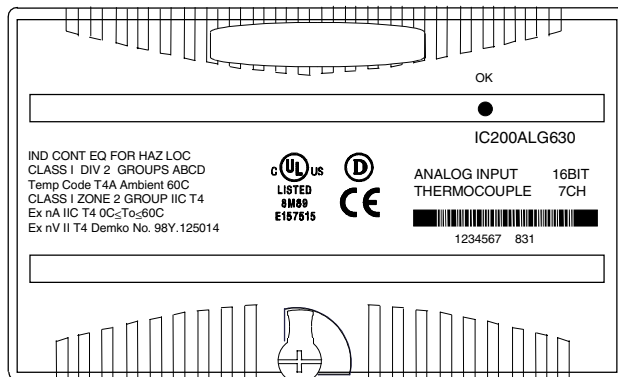

The module receives power from the backplane power supply. No external power source is required.

Each input channel can be configured to report millivolts ranges as 1/100 of millivolts, or thermocouple inputs as linearized temperature in tenths of degrees Celsius or Fahrenheit, with or without cold junction compensation.

LED Indicators

The green FLD PWR LED indicates the presence of both backplane power and field power for the analog field-side circuits. The absence of either backplane or field power turns off the FLD PWR LED.

The OK LED indicates module status:

- On green indicates normal operation
- Flashing green indicates boot mode or update
- Flashing amber indicates self-diagnostic error
- Off indicates no 3.3V backplane power

Diagnostics

The module reports over/under range, open thermocouple, non-volatile memory storage, high/low alarm and thermistor error diagnostics to the I/O Fault Table.

Calibration

The module automatically performs A/D calibration at powerup. Automatic calibration is then repeated periodically to compensate for changes in the ambient temperature.

Module Operation

The Thermocouple Input Module accepts seven inputs from thermocouples and converts them to digital values. The module supports a variety of thermocouple types.

The module converts each analog voltage into a binary (15 bits plus a sign bit) value representing tenths (1/10) of degrees Celsius or Fahrenheit. The result is read by the module's microprocessor. The microprocessor determines if the input is over or under its configured range, or if an open thermocouple condition exists.

Each input can be configured to report data as millivolt or temperature (tenths of degrees Celsius or Fahrenheit) measurements. When thermocouple inputs are measured, the module can be configured to monitor the thermocouple junction temperature and correct the input value for cold junction. If the module is configured to measure millivolts, the result of the analog-to-digital conversion is a value reported in hundredths (1/100) of millivolts (625mV range reports tenths of millivolts).

The module automatically performs A/D calibration at powerup. Automatic calibration is then repeated periodically to compensate for changes in the ambient temperature. New calibration values are filtered into the current calibration values.

Host Interface

The Thermocouple Input module uses the following data types:

- 7 words of analog input data.
- 7 optional words of analog output data.

The module exchanges data in the same manner as other types of I/O modules: it provides all its input data when requested.

Compatibility

This module is compatible with:

- VersaMax PLC CPU version IC200CPU001-BC firmware version 1.20 or later.
- Genius NIU version IC200GBI001-AB Firmware version 1.10 or later
- Profibus NIU version IC200PBI001-BB firmware version 1.10 or later
- DeviceNet NIU version IC200DBI001-AA Firmware version 1.10 or later

IC200ALG630
Analog Input, 16 Bit Thermocouple, 7 Channels

Module Specifications

Module Characteristics	
Channels	Seven thermocouple or millivolt inputs
Module ID	
Isolation:	
User input to logic (optical) and to frame ground	250VAC continuous; 1500VAC for 1 minute
Group to group	Not applicable
Channel to channel	None
LED indicators	OK LED: green indicates backplane power is present. Amber indicates module fault.
Backplane current consumption	5V output: 125mA maximum. 3.3V output: 125mA maximum.
External power supply	None
Thermal derating	None
Diagnostics	over/under range, open thermocouple, non-volatile memory storage, high/low alarm, thermistor error
Input Characteristics	
Thermocouple types	J, K, T, S, R, none (used for mV inputs)
Spans (+/-)	19.5mV, 39mV, 78.125mV, 156.25mV, 312.5mV, 625mV
Converter resolution	15 bits + sign
Cold junction compensation	If used, reference junction temperature is measured at thermocouple termination using a precision thermistor, or supplied by system, or by fixed configuration value.
Cold junction temperature error	+/-0.25 degree Celsius (local measurement). To reduce temperature transients, thermocouple terminations should not be installed in the same cabinet as high heat-dissipation assemblies.
Conformity error	+/-0.3 degree Celsius, +/-0.5 degree Fahrenheit.
Accuracy, at 25° C	
on voltage measurement:	+/-0.2%
on temperature measurement:	+/- 0.15%
Temperature sensitivity (0° to 60°C)	+/-0.004% of reading, +/-1.5µV per °Celsius referred to input
Normal mode rejection	60dB, at 50/60 Hz, 100% span
Common mode rejection	120 dB at 50/60Hz, 100 ohm imbalance
Common mode voltage	3 VDC maximum
Maximum voltage between channels	50V
Normal mode voltage	5 VDC maximum
Update rate	60 Hz: approximately 60 milliseconds per channel 50 Hz: approximately 70 milliseconds per channel

IC200ALG630
Analog Input, 16 Bit Thermocouple, 7 Channels

Configurable Parameters

The default parameters of the Thermocouple Input module can be used in many applications. The module can be software-configured when it is installed in a VersaMax PLC system, or an I/O Station controlled by a Network Interface Unit that is version 2.0 or above.

Module Parameter	Description	Default	Choices
Analog Input Data Length	Word length of the module's analog input data.	7	1 to 7
Analog Input Data Reference	Starting offset for the module's analog input data.		user selectable
Analog Output Data Length	Word length of the module's optional Reference Compensation data.	0	0 to 7
Analog Output Data Reference	Starting offset for the module's optional Reference Compensation data.		user selectable
Line Frequency	Specifies the line frequency. The module uses this data to control the sampling rate.	60 Hz	50 Hz, 60 Hz
Suppress Open Thermocouple	Determines whether or not the module will suppress Open Thermocouple diagnostics on the input data.	No	Yes, No
Channel Active	Specifies if the channel should return data and alarms. If a channel is "inactive" space is still allocated for it.	Active	Inactive (off) Active (on)
Engineering Units	Specifies how the module will report input values	1/10 degrees C	Millivolts, 1/10 degrees C, 1/10 degrees F
Thermocouple Type	The type of thermocouple present on each channel.	J	None, J, K, T, S, R
Range	For millivolt inputs only, the range for each channel in millivolts.	625	19.53, 39.06, 78.125, 156.25, 312.5, 625.
R J Type	Specifies how or whether the channel will perform Cold Junction compensation.	Local	Local, Remote, Fixed, None
Alarm Low	The low alarm limit for the channel, in engineering units.	-2000	-32,768 to +32,767
Alarm High	The high alarm limit for the channel, in engineering units.	8000	-32,768 to +32,767
Reference Junction Value	Specifies a reference value if Fixed RJ Type has been configured.	250	-32,768 to +32,767
Correction Factor	Specifies optional amount to be added to compensated and linearized input value when a Conversion Type in degrees has been configured.	0	-32,768 to +32,767
Channel Default Input	Specifies analog input returned upon error (including open circuit errors).	0	±32,767
Cold Junction Default		250	±32,767

IC200ALG630 **Analog Input, 16 Bit Thermocouple, 7 Channels**

Module Features

Channel Active

Each channel can be configured as either active or inactive. If a channel is inactive, the filtering, scaling, calibration, and alarm checks are omitted for that channel, and a value of 0 is returned for the channel. The reference parameter for the analog input data returns the byte length and is independent of the number of active channels.

Low Alarm Limit and High Alarm Limit

Each input channel can have a low alarm limit and a high alarm limit. If an input reaches one of its limits, the module reports the actual value and reports an alarm fault in the I/O Fault Table. Alarms do not stop the process or change the value of the input. Alarm limits can be set anywhere over the dynamic range of the signal. The range for each is $-32,768$ to $+32,767$. The high alarm limit must be greater than the low alarm limit. If alarm reporting is not wanted, alarm limits can be set beyond the dynamic range of the signal so they will never be activated.

Thermocouple Limits

The table below lists millivolt and temperature limits for applicable thermocouple types.

TC Type	Low mV Limit	High mV Limit	Low Temperature Limit ((C)	High Temperature Limit (C)
J	-8.0960	57.9420	-210.00	1000.00
K	-5.8910	54.8069	-200.00	1370.00
T	-5.6030	20.2520	-200.00	390.00
S	-0.1940	18.5040	-40.00	1750.00
R	-0.1880	20.8780	-40.00	1750.00

Cold Junction Compensation

The Thermocouple module provides four choices for Cold Junction Compensation.

- **No Cold Junction Compensation:** This is used for millivolt inputs or if cold junction is maintained at 0 degrees C.
- **Remote Cold Junction Compensation:** With this option, cold junction is measured externally and provided to the module from the application, via the module's analog output (word output) data. If the module has multiple thermocouples that are configured for remote compensation, the same compensation value must be used by each.
- **Fixed Cold Junction Compensation:** This option uses a fixed compensation value which is provided as part of the module configuration.
- **Local Cold Junction Compensation:** The best way to provide local compensation is with an Interposing Thermocouple I/O Terminals. (IC200CHS014), which has a built-in thermistor. Using an Interposing Carrier allows the thermocouple connections to be placed farther away from the I/O modules in the system, which helps shield thermocouple connections from module heat.

If Local Cold Junction Compensation is configured and an Interposing Thermocouple I/O Terminals is not used, a separate thermistor must be installed directly at the module's I/O Carrier, using the Thermistor (+) and Thermistor (-) terminals. The thermistor must be that supplied in kit # IC690ACC905. **Note:** If Local Compensation is selected but an Interposing Thermocouple I/O Terminals or local thermistor is not used, erroneous temperatures may be reported and a thermistor error will be reported in the fault table.

Range Selection

The module is configurable for any of six different millivolt ranges (+/-): 19.5mV, 39mV, 78.125mV, 156.25mV, 312.5mV, and 625mV. All but the last provide input readings in hundredths of millivolts. For the 625mV range, inputs are in tenths of millivolts. When used to read millivolts, the Thermocouple Type configuration parameter must be set to "none".

IC200ALG630 Analog Input, 16 Bit Thermocouple, 7 Channels

Installation Instructions

The preferred installation technique is to mount the Thermocouple Module on a VersaMax Connector-style I/O Carrier (IC200CHS003) and connect thermocouples to an Interposing Thermocouple I/O Terminals (IC200CHS014). The Interposing Thermocouple-style I/O Carrier provides both box-style wiring terminals and a built-in thermistor for Local Cold Junction Compensation. It connects to the Connector-Style Carrier via cable as shown below. This allows the thermocouple connections to be located away from the I/O modules in the system.

However, it is also possible to mount the Thermocouple Module on one of the terminal-style carriers (box-style, spring-style, compact-style, or barrier-style) and provide Local Cold Junction Compensation by using a kit that includes the correct type of thermistor (IC690ACC905). Both methods are shown below. The thermistor kit must be installed on the A9 and A10 terminals of the carrier.

If the module will only be used to measure millivolt inputs, not thermocouple inputs, it can be mounted on any type of I/O Carrier. The thermistor terminals A9 and A10 cannot be used as millivolt input terminals.

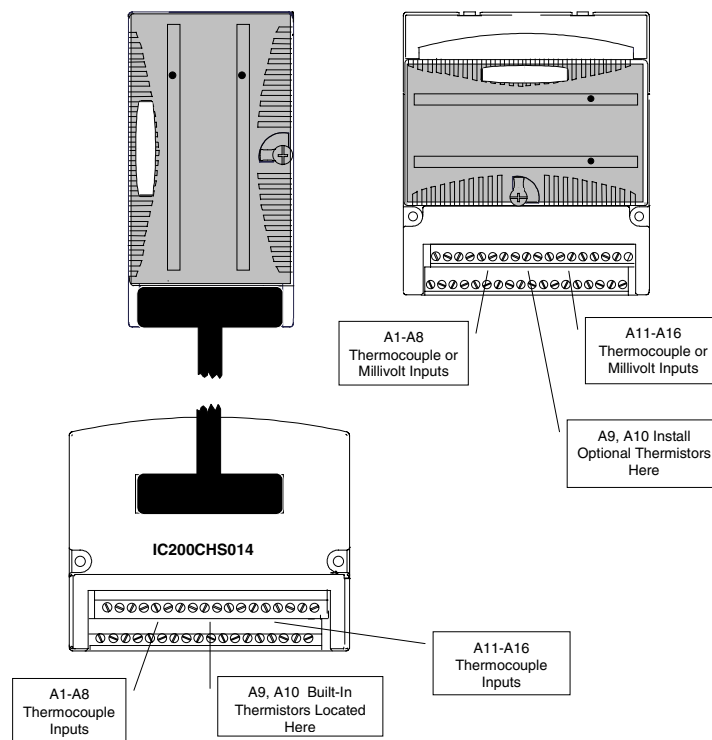

IC200ALG630
Analog Input, 16 Bit Thermocouple, 7 Channels

Field Wiring

The terminal assignments for the Thermocouple module shown below are the same for all carriers.

Terminal	Connection	Terminal	Connection
A1	Channel 1 (+)	B1	No Connection
A2	Channel 1 (-)	B2	Shield Termination Point
A3	Channel 2 (+)	B3	No Connection
A4	Channel 2 (-)	B4	Shield Termination Point
A5	Channel 3 (+)	B5	No Connection
A6	Channel 3 (-)	B6	Shield Termination Point
A7	Channel 4 (+)	B7	No Connection
A8	Channel 4 (-)	B8	Shield Termination Point
A9	(Thermistor (+))	B9	No Connection
A10	(Thermistor (-))	B10	Shield Termination Point
A11	Channel 5 (+)	B11	No Connection
A12	Channel 5 (-)	B12	Shield Termination Point
A13	Channel 6 (+)	B13	No Connection
A14	Channel 6 (-)	B14	Shield Termination Point
A15	Channel 7 (+)	B15	No Connection
A16	Channel 7 (-)	B16	No Connection
A17	No Connection	B17	No Connection
A18	No Connection	B18	No Connection

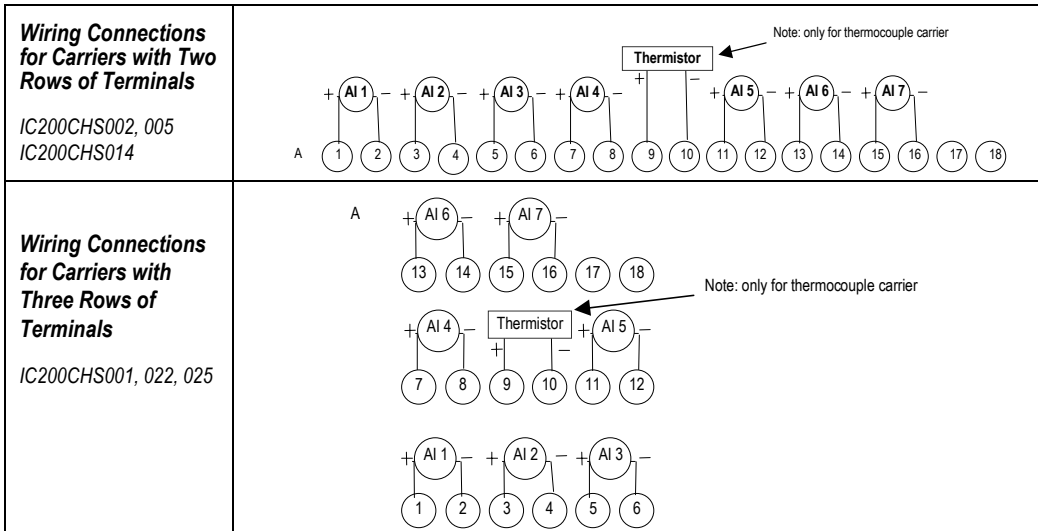

IC200ALG630
Analog Input, 16 Bit Thermocouple, 7 Channels**Cable Shield Connections**

If possible, the cable should be grounded at the source device. If that is not possible, the cable shield must be grounded at the source device. If that is not possible, the cable shield must be grounded at the I/O module. This can be done using an Auxiliary I/O Terminal (IC200TBM001, 002, or 005).

If the module is installed on a Terminal-style I/O Carrier (IC200CHS001, 002, or 005), shield connections can be made on an Auxiliary I/O Terminal that is attached to the I/O carrier.

If the module is installed on a Compact Terminal-style I/O Carrier (IC200CHS022, 025), shield connections can be made on an Auxiliary I/O Terminal that is mounted near the I/O carrier. Be sure to ground the Auxiliary I/O Terminal Strip if you plan to use it for this purpose.

If the module is installed on a Connector-style I/O Carrier (IC200CHS003), the cable shield can be connected directly to an Interposing Terminal (IC200CHS011, 012, 015). Be sure to ground the Interposing Terminal. It is recommended to use a shielded interposing cable as well between the Interposing Terminal and the Connector Base. A custom shielded cable can be made using the Connector kit (IC200ACC302). In addition, a custom shield braid can be wrapped around standard Interposing Cables (IC200CBL105, 110, 120, 230). If this approach is used be sure to ground the braid.

Diagnostics

The Thermocouple module performs diagnostics and provides the following information in the I/O fault table.

Alarm faults are reported if the processed value for a channel exceeds its configured alarm limit.

Over/underrange faults are reported if the millivolt value for an input exceeds the limits of its span.

Open circuit is checked every time a thermocouple input is read (unless Open TC checking is disabled). If the circuit is open, a fault is reported and the input defaults to the configured channel default (this is 0 unless re-configured). If the Thermocouple Type parameter has been configured as “none”, open circuit checking is not done.

After an Open Circuit fault condition is corrected, the module takes a few seconds to return to normal operation. During this time, the module continues reporting the channel default input value. After the module has recovered from the Open Circuit fault, it returns to normal inputs and normal operation.

If there is a very large change in an input (for example, an input quickly goes from 50mV to 400mV), the module may briefly report an Overrange fault on that circuit even though the circuit is not actually over its configured upper range limit. This is only temporary.

Thermistor Fault

A thermistor fault occurs if the calculated temperature value from the thermistor is less than -10 degrees C or greater than +75 degrees C.

Chapter 15

Accessories

This chapter describes the following VersaMax accessories:

- IC200ACC301 I/O Filler Module
- IC200ACC302 I/O Input Simulator
- IC200ACC303 I/O Shorting Bar

**IC200ACC301
I/O Filler Module**

The VersaMax I/O Filler Module (IC200ACC301) can be used as a placeholder for a future I/O module. The I/O Filler has no electrical components. It installs on any VersaMax I/O Carrier in the same way as an I/O module. The carrier is not wired to field devices. The I/O Filler Module protects the carrier electronics against contamination and mechanical damage and also gives the installed equipment a finished appearance.

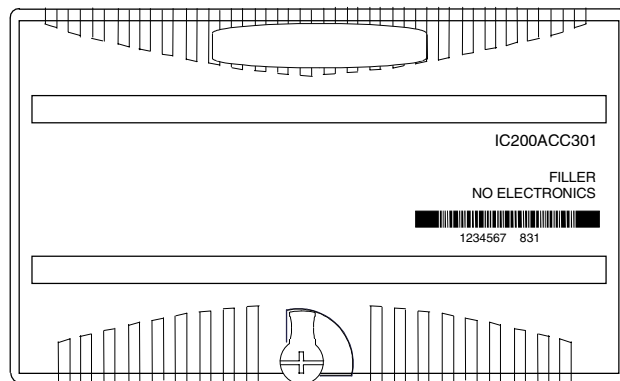

The CPU or NIU at the head of the equipment sees the carrier where the I/O Filler Module is installed as an “empty” slot. In a VersaMax PLC system that will be configured using the configuration software, the I/O Filler Module and its carrier can be located in any I/O module slot. However, in a system that will be configured using autoconfiguration, the I/O Filler Module and its carrier must be located in the last slot, because autoconfiguration stops at the first empty slot.

**IC200ACC302
Input Simulator**

The VersaMax Input Simulator (IC200ACC302) has 16 switches that can be used to easily turn on or off any input on a 24VDC VersaMax discrete input or mixed I/O module.

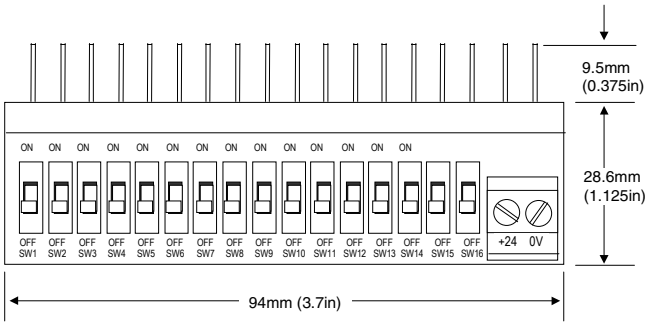

The module must be installed on an I/O Carrier with Box Style Terminals (IC200CHS002) or on a Connector-Type I/O Carrier with Box-Type Interposing Terminals (IC200CHS012) or Auxiliary Terminals (IC200TBM002). It can be installed in either the A or B terminals of the carrier.

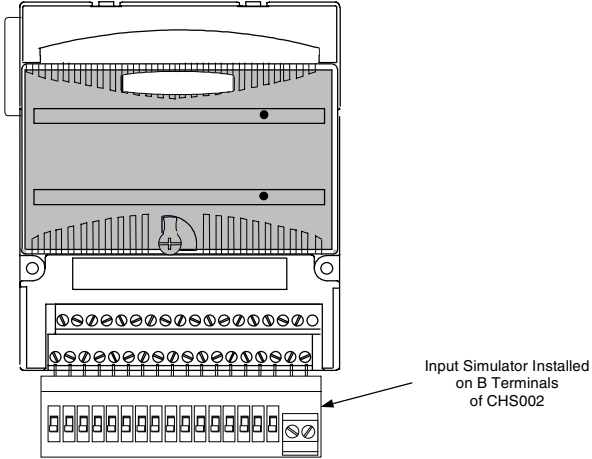

The Input Simulator can be installed in either the A or B terminals of the carrier, depending on which module inputs should be controlled. After inserting the pins of the Input Simulator, tighten down the screws on the carrier.

A separate external source of 24VDC power is required. The power supply specifications must be appropriate for the I/O module being controlled. The power supply connection terminals on the Input Simulator accommodate one solid or stranded AWG #14 (avg. 2.1mm² cross section) to AWG #22 (avg. 0.36mm² cross section) wire, or two wires up to AWG #18 (avg. 0.86mm² cross section).

IC200ACC303 I/O Shorting Bar

Shorting Bars (part number IC200ACC303, quantity 2) can be a cost-effective solution for providing additional bussed terminals for modules that include only one I/O board. The shorting bar has a maximum current-carrying capacity of 2 Amps per point. See the individual module descriptions to determine whether a shorting bar can be used for a particular module.

The figure below shows an example of how a Shorting Bar can be used to provide extra field wiring connections for an I/O module.

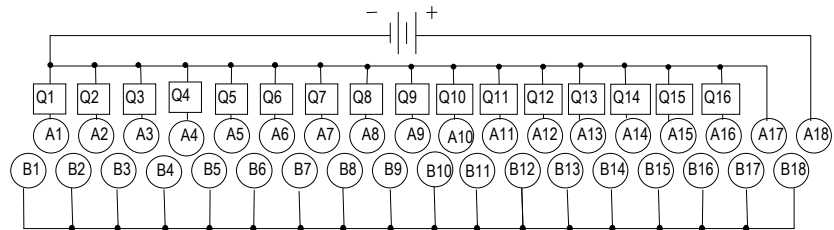

A Shorting Bar must be installed *directly on the carrier* before installing the I/O module.

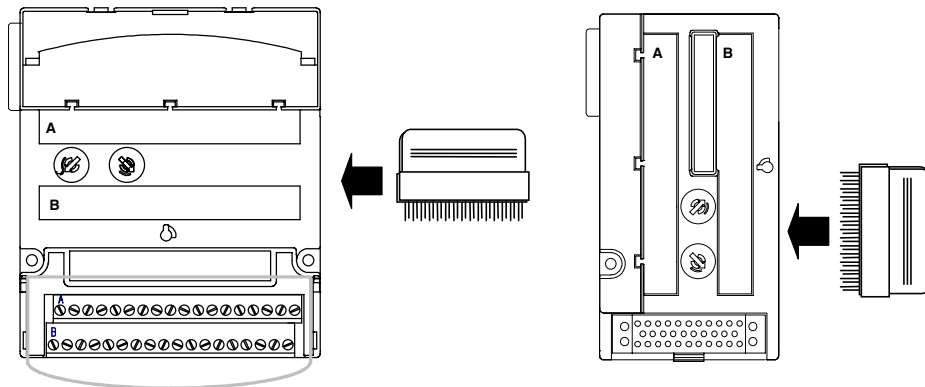

Appendix

A

Panel Mounting Dimensions

This section shows details for mounting the VersaMax modules.

- Module Space Requirements
- Panel Mounting Details

Thermal Considerations

The thermal performance specified for modules in this manual requires a clearance of 2 inches (5.1cm) above and below the modules and 1 inch (2.54cm) on each side of the modules as shown below, regardless of the orientation of the DIN rail.

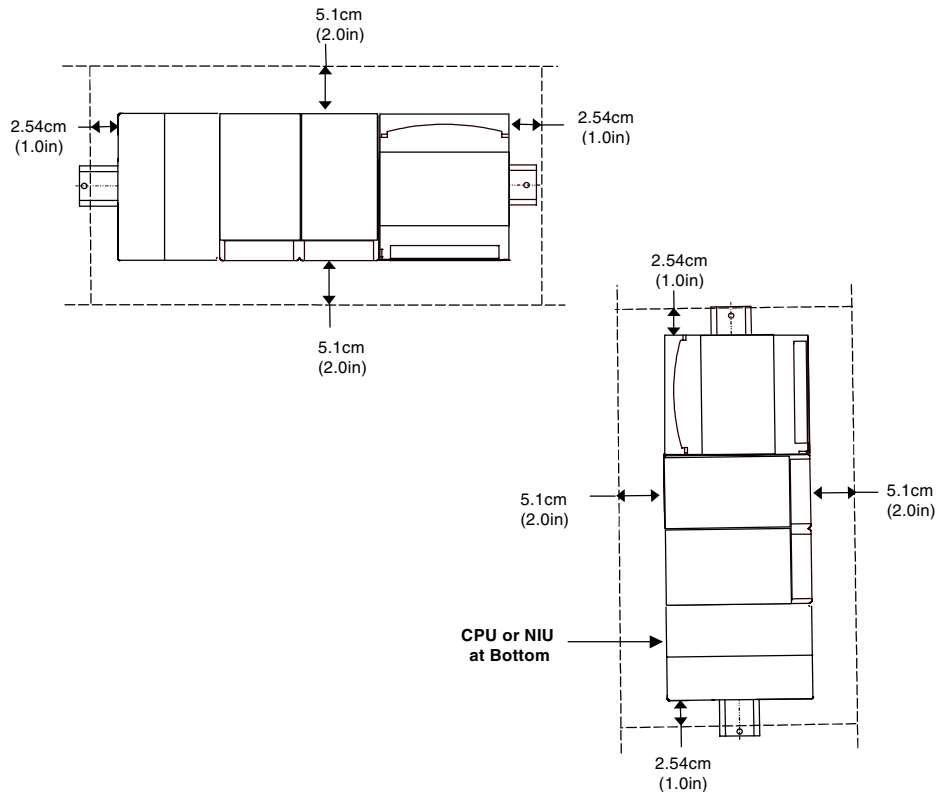

Mounting Modules on a Vertical DIN Rail

When using a vertical DIN rail, the CPU or NIU module must be installed at the bottom.

Some VersaMax I/O modules require thermal derating. The “Thermal Derating” section of these modules’ descriptions provides specific derating information. In general, mounting a module on a vertical DIN rail increases the ambient temperature around each module, due to the cumulative effect of the rising heat. Therefore, modules that have a thermal derating when mounted on a horizontal DIN rail will have a greater derating when mounted on a vertical DIN rail

Modules that do not have a thermal derating when mounted on a horizontal DIN rail also have no derating when installed on a vertical DIN rail.

Module Space Requirements

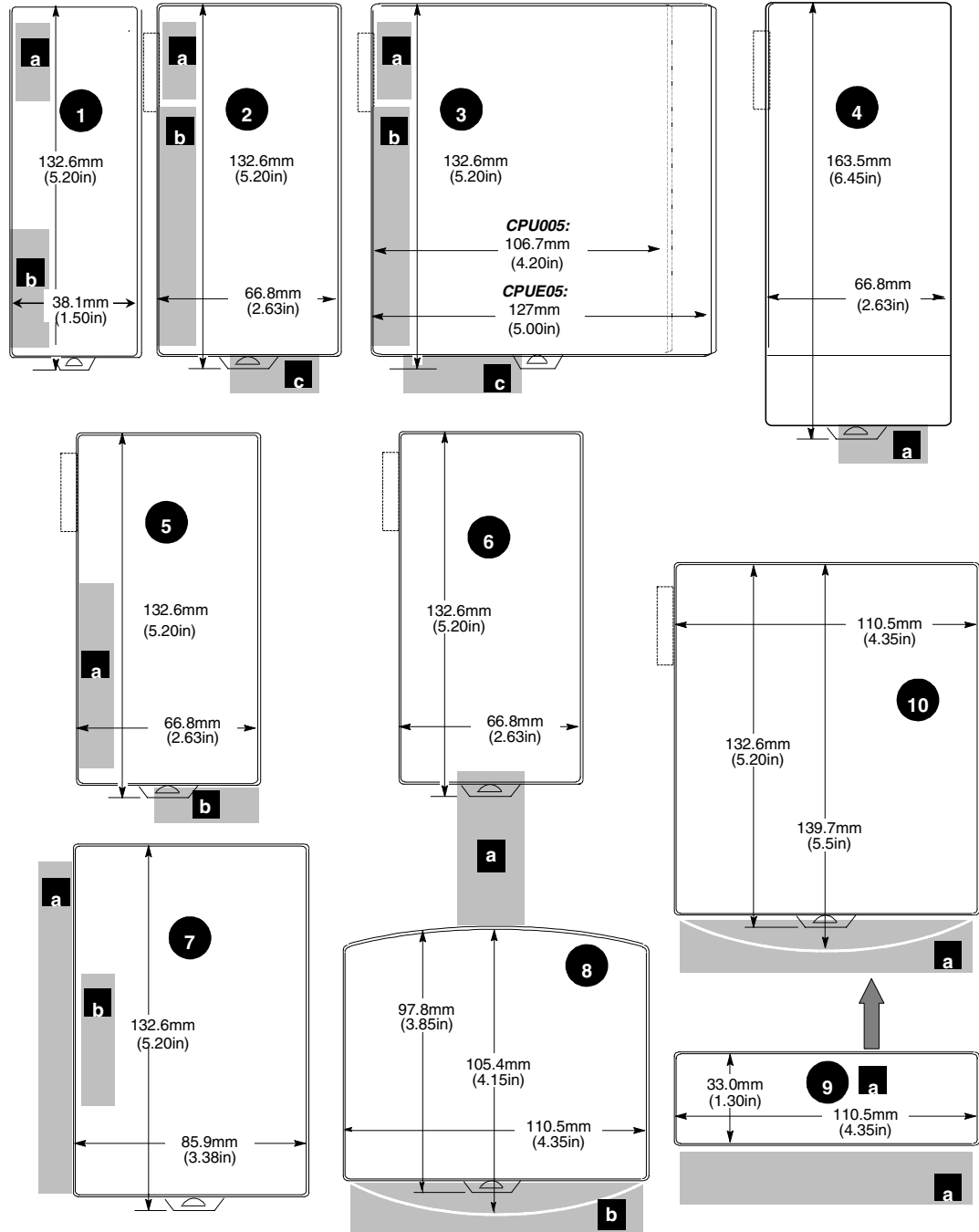

Module Sizes

The previous diagram shows the length and width of VersaMax Modules. Some modules have physical clearance requirements that should be considered when planning the layout of the system. Module carriers have a projecting connector on the left side that fits into the previous carrier. Clearance for this connector must be included in the overall equipment width allowed for potential future removal/insertion of a carrier. The clearance required per carrier is approximately 6.4mm (.25in).

- 1 Expansion Transmitter Module**
 - a In NIU I/O Station, allow clearance for cable to pass-through serial port
 - b Allow adequate space for expansion cable
- 2 CPU001 or 002, with Power Supply Module**
 - a Allow clearance for opening CPU door to access Run/Stop switch
 - b Allow adequate space for serial port cables
 - c Allow adequate space for power wiring
- 3 CPU005 / CPUE05 with Power Supply Module**
 - a Allow clearance for opening CPU door to access Run/Stop switch
 - b Allow adequate space for serial port cables
 - c Allow adequate space for power wiring
- 4 Compact Terminal Style I/O Carrier**
 - a Allow adequate space for device wiring
- 5 Expansion Receiver Module, Communications Module, or Power Supply Booster Carrier**
 - a (Expansion Receiver Module) Allow space for expansion cables
 - b (Booster Carrier) Allow adequate space for power wiring
- 6 Connector-Style I/O Carrier**
 - a Allow adequate space for cable. Use of Interposing Carrier is optional.
- 7 Network Interface Unit**
 - a Allow clearance for opening NIU door.
 - b Allow adequate clearance for cables
- 8 Interposing I/O Terminals**
 - b Allow adequate space for wiring
- 9 Auxiliary I/O Terminals**
 - a Multiple Auxiliary Terminals may be used.
 - b Allow adequate space for device wiring
- 10 Terminal-Style I/O Carrier**
 - a Allow adequate space for device wiring

Panel-Mounting Details

In installations where excessive vibration is a factor, the DIN-rail mounted carriers should also be installed on a panel. Mounting dimensions are shown on the following pages.

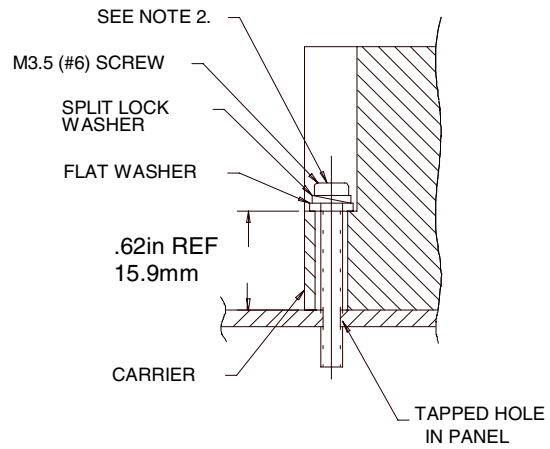
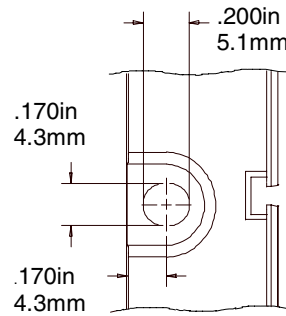

NOTES:

1. TOLERANCES ON ALL DIMENSIONS ARE $\pm 0.1\text{mm}$ (0.005IN) NON-CUMULATIVE.
2. 1.1-1.4Nm (10-12 IN. LBS) OF TORQUE SHOULD BE TO M3.5 (#6-32) STEEL SCREW THREADED INTO MATERIAL CONTAINING INTERNAL THREADS AND HAVING A MINIMUM THICKNESS OF 2.4mm (.093 IN).

CPU or Expansion Receiver Module to Connector-Style I/O Carrier (Shown), Compact Terminal-Style I/O Carrier, or Communications Carrier

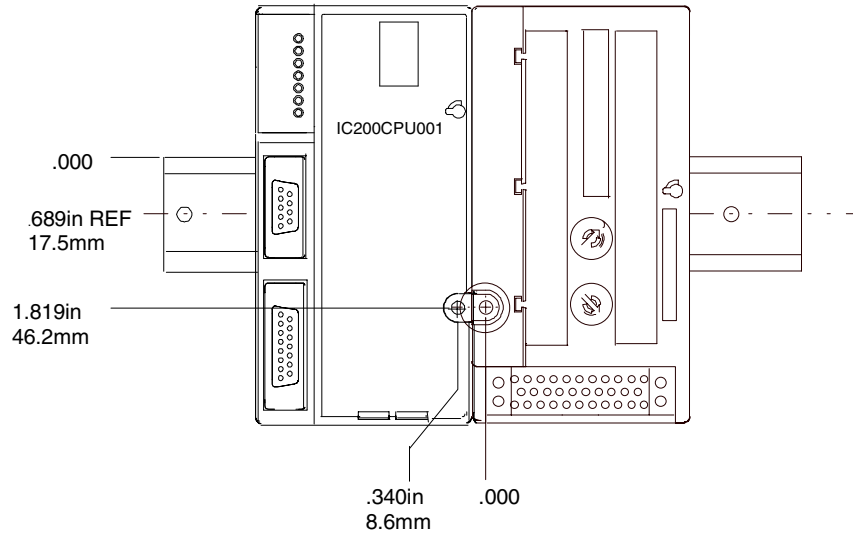

CPU or Expansion Receiver Module to Terminal-Style I/O Carrier

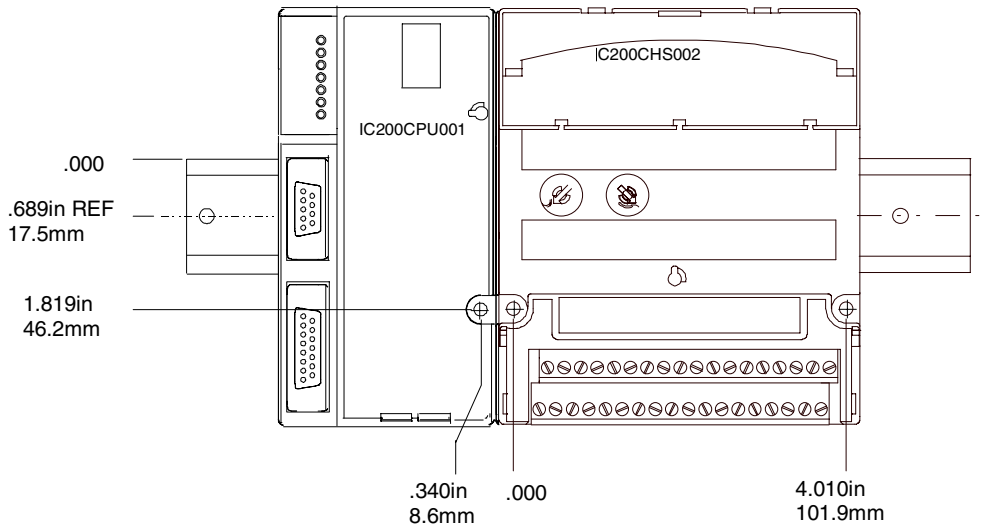

NIU to Connector-Style I/O Carrier(Shown), or Compact Terminal-Style I/O Carrier

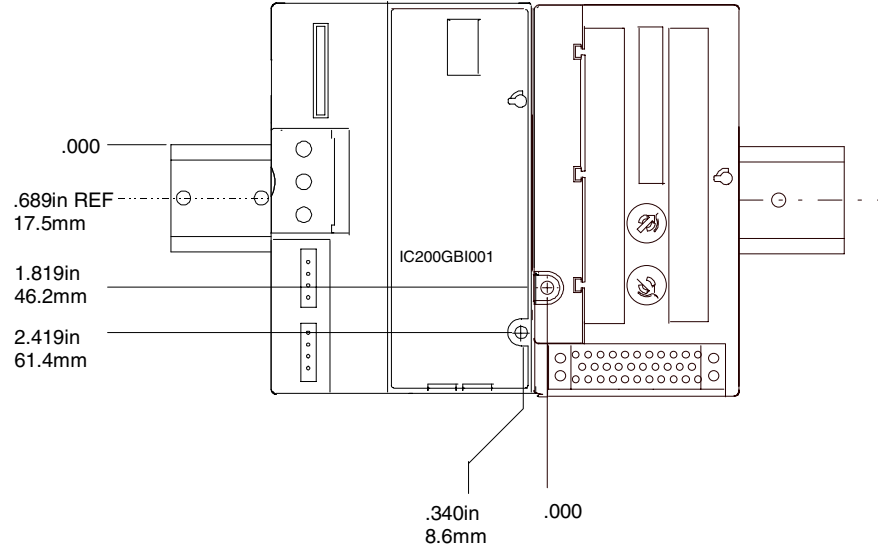

NIU to Terminal-Style I/O Carrier

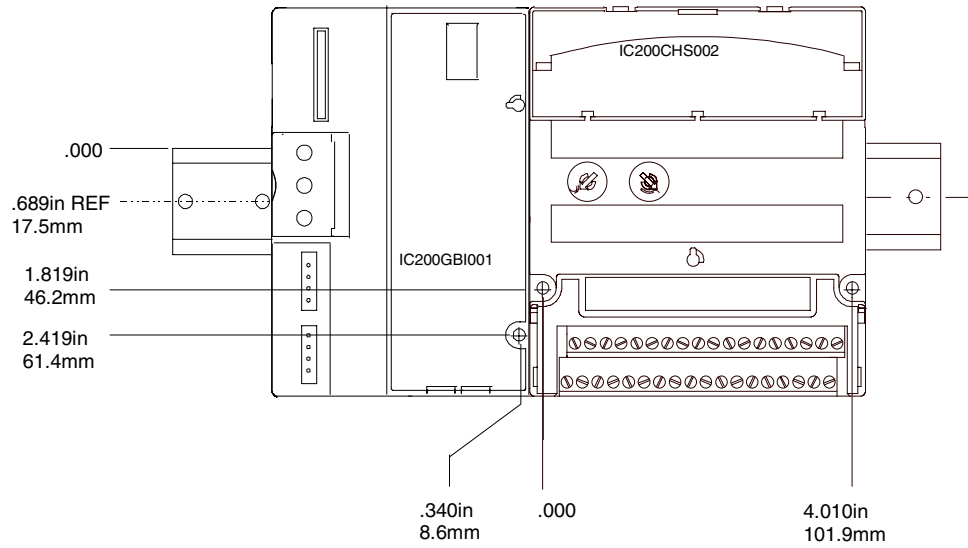

A

Terminal-Style I/O Carrier to Terminal-Style I/O Carrier and Auxiliary Terminals to Terminal-Style I/O Carrier

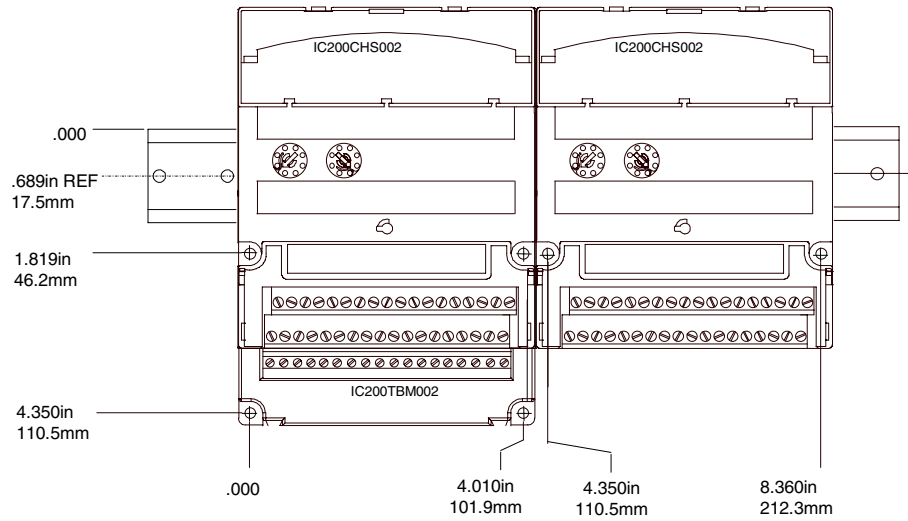

Terminal-Style Carrier to Connector-Style Carrier (shown), Compact Terminal-Style I/O Carrier, or Power Supply Booster Carrier

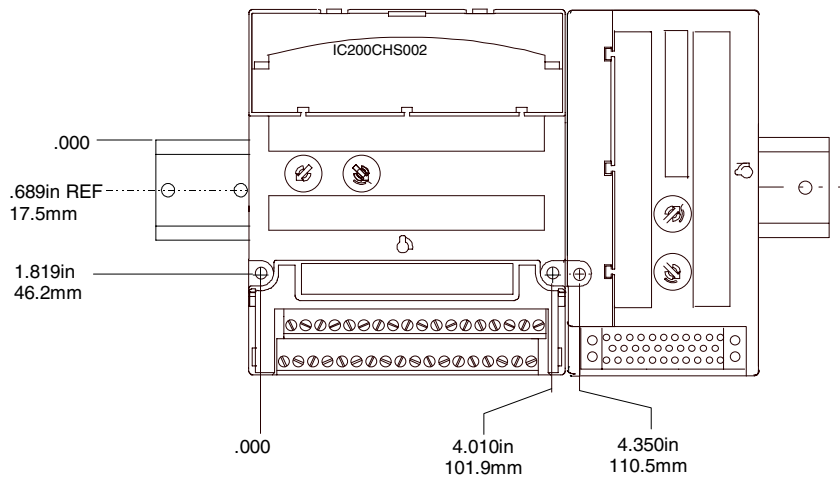

Connector-Style I/O Carrier to Connector-Style I/O Carrier (shown), Compact Terminal-Style I/O Carrier, Communications Carrier, or Power Supply Booster Carrier

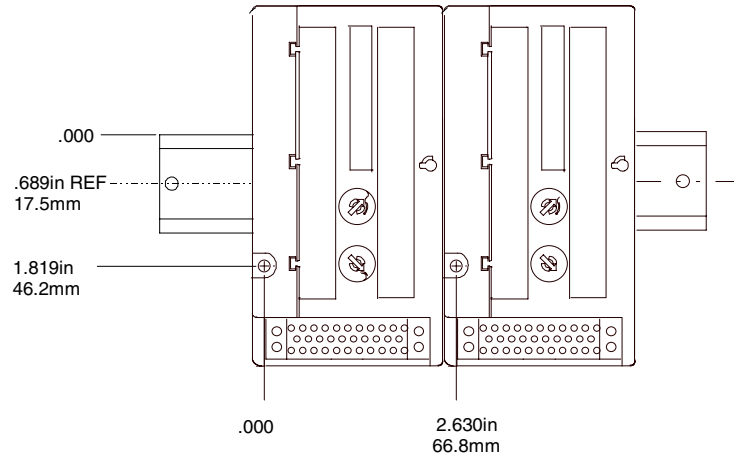

Interposing Terminals to Interposing Terminals

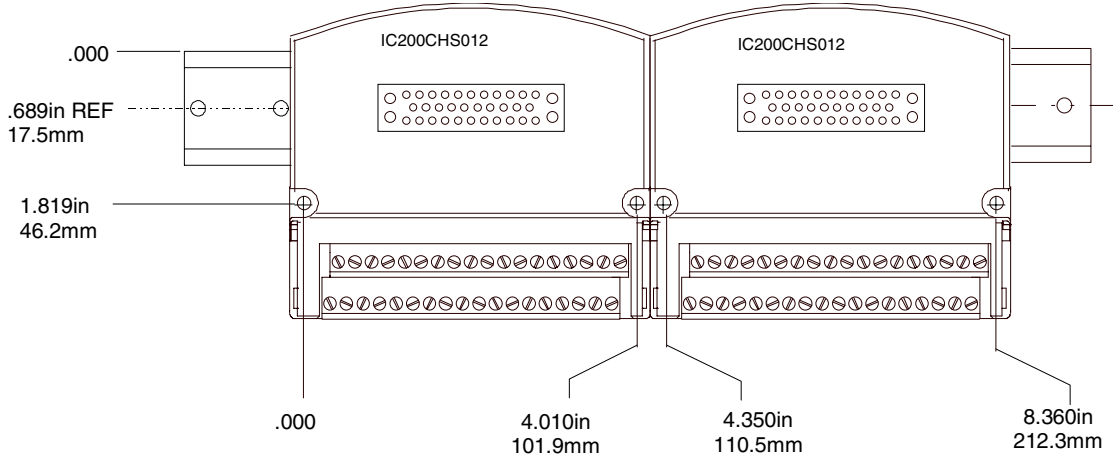

Connector-Style I/O Carrier (shown) or Compact Terminal-Style I/O Carrier to Terminal-Style I/O Carrier

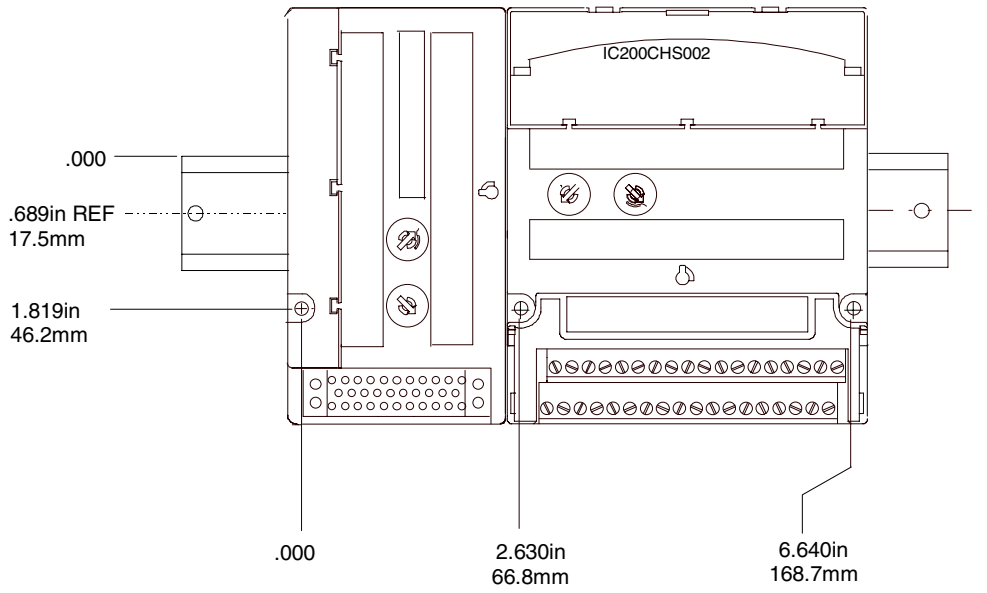

Example Mounting Dimensions

In an expansion system, the Expansion Transmitter Module adds 38.1mm (1.5in) to the left side of the CPU or NIU in rack 0, represented below.

NIU (Shown) CPU,
or ERM Module

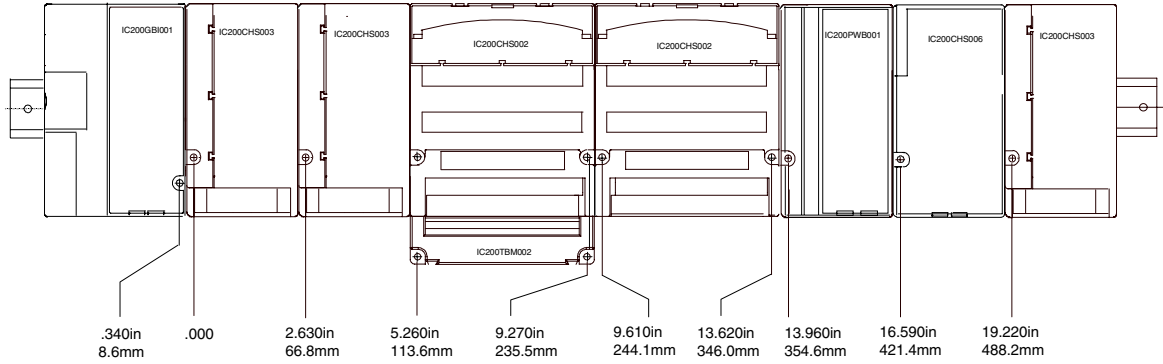

Each expansion rack in an expansion system has an Expansion Receiver Module in slot 0, with additional modules as shown above.

Appendix
B

Relay Contact Ratings

Mechanical Rating

Relay contacts are rated for 10⁷ operations.

Electrical Rating

The relay contact use in VersaMax modules meet Underwriters Laboratories' Pilot Duty Rating for Control Circuits. Contact life depends on type of load and current, as summarized in the table below.

Operating Voltage	Maximum Current for Load Type		Typical Contact Life (operations)
	Resistive	Inductive *	
24 to 125VAC	2.0 Amp	0.35 Amp	300,000
24 to 125VAC	–	1.00 Amp	100,000
24 to 125VAC	1.5 Amp	0.20 Amp	500,000
24 to 125VAC	0.8 Amp	0.10 Amp	1,000,000
250VAC	2.0 Amp	0.15 Amp	180,000
250VAC	–	1.00 Amp	30,000
250VAC	1.0 Amp	–	500,000
250VAC	0.6 Amp	–	1,000,000
5 to 31VDC	2.0 Amp	0.70 Amp	200,000
5 to 31VDC	–	2.00 Amp	50,000
5 to 31VDC	1.1 Amp	0.25 Amp	500,000
5 to 31VDC	0.7 Amp	0.10 Amp	1,000,000
32 to 125VDC	0.2 Amp	not rated	300,000

* Power Factor = 0.4 minimum for AC inductive loads
Time Constant – 7mS for DC inductive loads

Installing suitable suppression across inductive loads enhances reliability. For DC, a free-wheeling diode provides suitable suppression. For AC, an R-C filter can be used.

B

Appendix
C

Power Supply Load Requirements

This appendix summarizes the DC load requirements of all types of VersaMax modules.

It also describes how to calculate the Power Supply requirements of a VersaMax system.



Power Supply Capacities

The Power Supply on the CPU or NIU module provides +5V and +3.3V power to the modules in the station. Booster Power Supplies can be used if the modules in the system will draw more current than the CPU or NIU Power Supply can provide. The AC or DC Power Supply on the CPU or NIU and the Power Supply that resides on the Booster Carrier must share the same external power source.

For each Power Supply, the maximum total combined output current from the 5V and 3.3V outputs is 1.5 Amps. Each power supply provides a maximum of either 0.25 Amp or 1 Amp on its 3.3V output, as listed in the next table. That portion of the Power Supply's total output current not drawn from the 3.3V output is available via the 5.5V output.

Catalog Number	Description	Maximum Output Current in Amps		
		Total (5V + 3.3V)	5V	3.3V
IC200PWR001	24VDC Power Supply	1.5A	(1.5A – I _{3.3V})	0.25A
IC200PWR002	24VDC Expanded 3.3V Power Supply	1.5A	(1.5A – I _{3.3V})	1.0A
IC200PWR101	120/240VAC Power Supply	1.5A	(1.5A – I _{3.3V})	0.25A
IC200PWR102	120/240VAC Expanded 3.3V Power Supply	1.5A	(1.5A – I _{3.3V})	1.0A
IC200PWR201	12VDC Power Supply	1.5A	(1.5A – I _{3.3V})	0.25A
IC200PWR202	12VDC Expanded 3.3V Power Supply	1.5A	(1.5A – I _{3.3V})	1.0A

Power Calculation Example

In the example system listed below, the maximum current draw on the Power Supply's 3.3V output by all of the modules will be 0.215 Amp.

Subtracting 0.215A from the Power Supply total output of 1.5A shows that 1.285A will be available via the 5.5V output:

$$(1.5A - 0.215A = 1.285A)$$

Because the maximum current draw on the 5V output would be 0.65A as shown in the table below, any of the available Power Supplies could be used for this system.

Catalog Number	Description	Backplane Current Consumption in mA	
		5V	3.3V
IC200CPU001	CPU with 2 serial ports, with EZ Program Store device	140	100
IC200ALG261	Analog Input Module, 15 Bit Voltage Differential 8 Channels	200	
IC200ALG327	Analog Output Module, 13 Bit Voltage 12 Channels	50	
IC200ALG331	Analog Output Module, 16 Bit Voltage/Current, 1500VAC Isolation, 4 Channels	10	115
IC200MDL650	Input Module, 24VDC Positive/Negative Logic 32 Points	50	
IC200MDL650	Input Module, 24VDC Positive/Negative Logic 32 Points	50	
IC200MDL742	Output Module, 24VDC Positive Logic 0.5 Amp, w/ESCP 32 Pts	150	
Total Current Required by Modules		650mA (0.65A)	215mA (0.215A)

Module Power Requirements

Catalog Number	Description		Backplane Current Consumption in mA	
			5V	3.3V
IC200CPU001, IC200CPU002	CPU with 2 serial ports	no serial port converter or EZ Program Store device	40	100
		with serial port converter or EZ Program Store device	140	
IC200CPU005	CPU with 2 serial ports	no serial port converter or EZ Program Store device	80	290
		with serial port converter or EZ Program Store device	180	
IC200CPUE05	CPU with 2 serial ports, embedded Ethernet interface	no serial port converter or EZ Program Store device	160	650
		with serial port converter or EZ Program Store device	260	
IC200EBI001	Ethernet Network Interface Module		175	425
IC200GBI001	Genius Network Interface Module		250	10
IC200PBI001	Profibus Network Interface Module		450	10
IC200DBI001	DeviceNet Network Interface Module		160	10
IC200BEM102	Profibus Network Slave Module		350	
IC200BEM103	DeviceNet Network Control Module		140	
IC200BEM104	AS-i Network Interface Module		350	
IC200ETM001	Expansion Transmitter Module		44	
IC200ERM001	Expansion Receiver Module, Isolated		430	20
IC200ERM002	Expansion Receiver Module		70	20
IC200ALG230	Analog Input Module, 12 Bit Voltage/Current 4 Channels		125	
IC200ALG240	Analog Input Module, 16 Bit Voltage/Current, 1500VAC Isolation, 8 Channels		15	120
IC200ALG260	Analog Input Module, 12 Bit Voltage/Current 8 Channels		130	
IC200ALG261	Analog Input Module, 15 Bit Voltage Differential 8 Channels		200	
IC200ALG262	Analog Input Module, 15 Bit Current Differential 8 Channels		200	
IC200ALG263	Analog Input Module, 15 Bit Voltage 15 Channels		150	
IC200ALG264	Analog Input Module, 15 Bit Current 15 Channels		100	



Catalog Number	Description	Backplane Current Consumption in mA	
		5V	3.3V
IC200ALG320	Analog Output Module, 12 Bit Current, 4 Channels	50	
IC200ALG321	Analog Output Module, 12 Bit Voltage 0 to 10VDC 4 Channels	50	
IC200ALG322	Analog Output Module, 12 Bit Voltage -10 to +10VDC 4 Channels	50	
IC200ALG325	Analog Output Module, 13 Bit Voltage 8 Channels	50	
IC200ALG326	Analog Output Module, 13 Bit Current 8 Channels	50	
IC200ALG327	Analog Output Module, 13 Bit Voltage 12 Channels	50	
IC200ALG328	Analog Output Module, 13 Bit Current 12 Channels	50	
IC200ALG331	Analog Output Module, 16 Bit Voltage/Current, 1500VAC Isolation, 4 Channels	10	115
IC200ALG430	Analog Mixed Module, 12 Bit Input Current 4 Channels and Output Current 2 Channels	50	
IC200ALG431	Analog Mixed Module, 12 Bit 0 to 10VDC Input 4 Channels and Output 2 Channels	60	
IC200ALG432	Analog Mixed Module, 12 Bit +/-10VDC Input 4 Channels and Output 2 Channels	60	
IC200ALG620	Analog Input Module, 16 Bit RTD, 4 Channels	125	125
IC200ALG630	Analog Input Module, 16 Bit Thermocouple, 7 Channels	125	125
IC200MDD840	Mixed Module, 24VDC Positive Logic Input 20 Points / Output Relay 2.0 Amp 12 Points	375	
IC200MDD841	Mixed Module, 24VDC Positive Logic Input 20 Points / Output 12 Point / (4) High Speed Counter, PWM, or Pulse Train Configurable Points	30	130
IC200MDD842	Mixed Module, Output 24VDC Pos. Logic 0.5A Grouped w/ESCP 16 Points / Input 24VDC Pos/Neg Logic Grouped 16 Points	100	
IC200MDD843	Mixed Module, 24VDC Positive Logic Input Grouped 10 Points / Output Relay 2.0A per Point Grouped 6 Points	190	
IC200MDD844	Mixed Module, Output 12/24VDC Pos. Logic 0.5A 16 Points / Input 24 VDC Pos/Neg Logic Grouped 16 Points	70	
IC200MDD845	Mixed Module, Output Relay 2.0A Isolated 8 Points / Input 24VDC Pos/Neg Logic Grouped 16 Points	270	
IC200MDD846	Mixed Module, Output Relay 2.0A per Pt Isolated 8 Points / Input 120VAC Grouped 8 Points	300	
IC200MDD847	Mixed Module, Output Relay 2.0A per Pt Isolated 8 Points / Input 240VAC Grouped 8 Points	300	
IC200MDD848	Mixed Module, Output 120VAC 0.5A per Pt Isolated 8 Points / Input 120VAC Grouped 8 Points	125	
IC200MDD849	Mixed Module, Output Relay 2.0A per Pt Isolated 8 Points / Input 120VAC Isolated 8 Points	295	
IC200MDD850	Mixed Module, Output Relay 2.0A per Pt Isolated 8 Points / Input 240VAC Isolated 4 Points	275	
IC200MDD851	Mixed Module, Output 12/24VDC Pos. Grouped 16 Pts / Input 5/12VDC Pos/Neg Grp16 Pts	115	

Catalog Number	Description	Backplane Current Consumption in mA	
		5V	3.3V
IC200MDL140	Input Module, 120VAC 8 Points	55	
IC200MDL141	Input Module, 240VAC 8 Points	55	
IC200MDL143	Input Module, 120VAC Isolated 8 Points	50	
IC200MDL144	Input Module, 240VAC Isolated 4 Points	30	
IC200MDL240	Input Module, 120VAC 16 Points	110	
IC200MDL241	Input Module, 240VAC 16 Points	110	
IC200MDL243	Input Module, 120VAC Isolated 16 Points	100	
IC200MDL244	Input Module, 240VAC Isolated 8 Points	60	
IC200MDL329	Output Module, 120VAC 0.5 Amp, Isolated 8 Points	70	
IC200MDL330	Output Module, 120VAC 0.5 Amp, Isolated 16 Points	140	
IC200MDL331	Output Module, 120VAC 2.0 Amp, Isolated 8 Points	85	
IC200MDL631	Input Module, 125VDC Positive/Negative Logic Isolated 8 Points	40	
IC200MDL632	Input Module, 125VDC Positive/Negative Logic Isolated 16 Points	80	
IC200MDL635	Input Module, 48VDC Positive/Negative Logic Grouped 16 Points	70	
IC200MDL636	Input Module, 48VDC Positive/Negative Logic Grouped 32 Points	140	
IC200MDL640	Input Module, 24VDC Positive/Negative Logic 16 Points	25	
IC200MDL643	Input Module, 5/12VDC Positive/Negative Logic Grouped 16 Points	70	
IC200MDL644	Input Module, 5/12VDC Positive/Negative Logic Grouped 32 Point	140	
IC200MDL650	Input Module, 24VDC Positive/Negative Logic 32 Points	50	
IC200MDL730	Output Module, 24VDC Positive Logic 2.0 Amps, w/ESCP 8 Points	50	
IC200MDL740	Output Module, 12/24VDC Positive Logic 0.5 Amp, 16 Points	45	
IC200MDL741	Output Module, 24VDC Positive Logic 0.5 Amp, w/ESCP 16 Points	75	
IC200MDL742	Output Module, 24VDC Positive Logic 0.5 Amp, w/ESCP 32 Points	150	
IC200MDL743	Output Module, 5/12/24V DC Negative Logic 0.5 Amp, 16 Points	70	
IC200MDL744	Output Module, 5/12/24VDC Negative Logic 0.5 Amp, 32 Points	140	
IC200MDL750	Output Module, 12/24VDC Positive Logic 0.5 Amp, 32 Points	90	
IC200MDL930	Output Module, Relay 2.0 Amp Isolated Form A 8 Points	245	
IC200MDL940	Output Module, Relay 2.0 Amp, Isolated Form A 16 Points	490	

Appendix
D

I/O Module Keying Summary

The following table summarizes keying for I/O modules:

Catalog Number	Module	Keycode
IC200ALG230	Analog Input Module, 12 Bit Voltage/Current 4 Channels	D2
IC200ALG240	Analog Input Module, 16 Bit Voltage/Current, 1500VAC Isolation, 8 Channels	C7
IC200ALG260	Analog Input Module, 12 Bit Voltage/Current 8 Channels	D2
IC200ALG261	Analog Input Module, 15 Bit Voltage Differential 8 Channels	G3
IC200ALG262	Analog Input Module, 15 Bit Current Differential 8 Channels	G2
IC200ALG263	Analog Input Module, 15 Bit Voltage 15 Channels	G3
IC200ALG264	Analog Input Module, 15 Bit Current 15 Channels	G2
IC200ALG320	Analog Output Module, 12 Bit Current, 4 Channels	B8
IC200ALG321	Analog Output Module, 12 Bit Voltage 0 to 10VDC 4 Channels	D6
IC200ALG322	Analog Output Module, 12 Bit Voltage -10 to +10VDC 4 Channels	E3
IC200ALG325	Analog Output Module, 13 Bit Voltage 8 Channels	G6
IC200ALG326	Analog Output Module, 13 Bit Current 8 Channels	G7
IC200ALG327	Analog Output Module, 13 Bit Voltage 12 Channels	G6
IC200ALG328	Analog Output Module, 13 Bit Current 12 Channels	G7
IC200ALG331	Analog Output Module, 16 Bit Voltage/Current, 1500VAC Isolation, 4 Channels	D7
IC200ALG430	Analog Mixed Module, 12 Bit Input Current 4 Channels and Output Current 2 Channels	D8
IC200ALG431	Analog Mixed Module, 12 Bit 0 to 10VDC Input 4 Channels and Output 2 Channels	E2
IC200ALG432	Analog Mixed Module, 12 Bit +/-10VDC Input 4 Channels and Output 2 Channels	E4
IC200ALG620	Analog Input Module, 16 Bit RTD, 4 Channels	D3
IC200ALG630	Analog Input Module, 16 Bit Thermocouple, 7 Channels	D4
IC200MDD840	Mixed Module, 24VDC Positive Logic Input 20 Points / Output Relay 2.0 Amp 12 Points	C3
IC200MDD841	Mixed Module, 24VDC Positive Logic Input 20 Points / Output 12 Point / (4) High Speed Counter, PWM, or Pulse Train Configurable Points	C4



Catalog Number	Module	Keycode
IC200MDD842	Mixed Module, Output 24VDC Pos. Logic 0.5A Grouped w/ESCP 16 Points / Input 24VDC Pos/Neg Logic Grouped 16 Points	C6
IC200MDD843	Mixed Module, 24VDC Positive Logic Input Grouped 10 Points / Output Relay 2.0A per Point Grouped 6 Points	C3
IC200MDD844	Mixed Module, Output 12/24VDC Pos. Logic 0.5A 16 Points / Input 24 VDC Pos/Neg Logic Grouped 16 Points	C6
IC200MDD845	Mixed Module, Output Relay 2.0A Isolated 8 Points / Input 24VDC Pos/Neg Logic Grouped 16 Points	E6
IC200MDD846	Mixed Module, Output Relay 2.0A per Pt Isolated 8 Points / Input 120VAC Grouped 8 Points	E7
IC200MDD847	Mixed Module, Output Relay 2.0A per Pt Isolated 8 Points / Input 240VAC Grouped 8 Points	E8
IC200MDD848	Mixed Module, Output 120VAC 0.5A per Pt Isolated 8 Points / Input 120VAC Grouped 8 Points	F2
IC200MDD849	Mixed Module, Output Relay 2.0A per Pt Isolated 8 Points / Input 120VAC Isolated 8 Points	E7
IC200MDD850	Mixed Module, Output Relay 2.0A per Pt Isolated 8 Points / Input 240VAC Isolated 4 Points	E8
IC200MDD851	Mixed Module, Output 12/24VDC Pos. Grouped 16 Pts / Input 5/12VDC Pos/Neg Grp 16 Pts	F3
IC200MDL140	Input Module, 120VAC 8 Points	B2
IC200MDL141	Input Module, 240VAC 8 Points	B3
IC200MDL143	Input Module, 120VAC Isolated 8 Points	B2
IC200MDL144	Input Module, 240VAC Isolated 4 Points	B3
IC200MDL240	Input Module, 120VAC 16 Points	B2
IC200MDL241	Input Module, 240VAC 16 Points	B3
IC200MDL243	Input Module, 120VAC Isolated 16 Points	B2
IC200MDL244	Input Module, 240VAC Isolated 8 Points	B3
IC200MDL329	Output Module, 120VAC 0.5 Amp, Isolated 8 Points	B6
IC200MDL330	Output Module, 120VAC 0.5 Amp, Isolated 16 Points	B6
IC200MDL331	Output Module, 120VAC 2.0 Amp, Isolated 8 Points	B7
IC200MDL631	Input Module, 125VDC Positive/Negative Logic Isolated 8 Points	F6
IC200MDL632	Input Module, 125VDC Positive/Negative Logic Isolated 16 Points	F6
IC200MDL635	Input Module, 48VDC Positive/Negative Logic Grouped 16 Points	F4
IC200MDL636	Input Module, 48VDC Positive/Negative Logic Grouped 32 Points	F4
IC200MDL640	Input Module, 24VDC Positive/Negative Logic 16 Points	B4
IC200MDL643	Input Module, 5/12VDC Positive/Negative Logic Grouped 16 Points	F3
IC200MDL644	Input Module, 5/12VDC Positive/Negative Logic Grouped 32 Point	F3
IC200MDL650	Input Module, 24VDC Positive/Negative Logic (32 Points)	B4

Catalog Number	Module	Keycode
IC200MDL730	Output Module, 24VDC Positive Logic 2.0 Amps, w/ESCP 8 Points	C2
IC200MDL740	Output Module, 12/24VDC Positive Logic 0.5 Amp, 16 Points	C2
IC200MDL741	Output Module, 24VDC Positive Logic 0.5 Amp, w/ESCP 16 Points	C2
IC200MDL742	Output Module, 24VDC Positive Logic 0.5 Amp, w/ESCP 32 Points	C2
IC200MDL743	Output Module, 5/12/24V DC Negative Logic 0.5 Amp, 16 Points	C2
IC200MDL744	Output Module, 5/12/24VDC Negative Logic 0.5 Amp, 32 Points	C2
IC200MDL750	Output Module, 12/24VDC Positive Logic 0.5 Amp, 32 Points	C2
IC200MDL930	Output Module, Relay 2.0 Ampt Isolated Form A 8 Points	C8
IC200MDL940	Output Module, Relay 2.0 Amp, Isolated Form A 16 Points	C8

D

A

- AC power selection, 3-9
- AC power selection jumper, 2-13
- Accumulator
 - type B operation, 13-12, 13-13
- Analog input module
 - IC200ALG620, 14-2
 - IC200ALG630, 14-10
- Analog input module IC200ALG230, 10-2
- Analog input module IC200ALG240, 10-9
- Analog input module IC200ALG260, 10-17
- Analog input module IC200ALG261, 10-24
- Analog input module IC200ALG262, 10-29
- Analog input module IC200ALG263, 10-36
- Analog input module IC200ALG264, 10-42
- Analog mixed module IC200ALG430, 12-2
- Analog mixed module IC200ALG431, 12-9
- Analog mixed module IC200ALG432, 12-16
- Analog output module IC200ALG320, 11-2
- Analog output module IC200ALG321, 11-9
- Analog output module IC200ALG322, 11-15
- Analog output module IC200ALG325, 11-21
- Analog output module IC200ALG326, 11-28
- Analog output module IC200ALG327, 11-34
- Analog output module IC200ALG328, 11-41
- Analog output module IC200ALG331, 11-48
- Analog wiring, 2-11
- Auxiliary I/O Terminals, 2-32

B

- Backplane current draw for modules, C-3
- Barrier-Style Auxiliary I/O Terminals, 5-19
- Barrier-Style I/O Carrier, 4-2
- Box-Style Auxiliary I/O Terminals, 5-20
- Box-Style I/O Carrier, 4-5

C

- Cable installation and removal, 2-21
- Cable shielding for analog modules, 2-20
- Cable wiring
 - for Connector Carrier, 2-22
- Cables, 2-20
- Carrier requirement for IC200MDL144, 7-13
- Carrier requirement for IC200MDL244, 7-27

- Carriers, 1-13
 - connecting, 2-4
- Color code on modules, 1-9
- Communications and signal wiring, 2-11
- Communications Modules for VersaMax, 1-17
- Compact Box-Style I/O Carrier, 4-14
- Compact Spring-Style I/O Carrier, 4-17
- COMREQ function block
 - High Speed Counters, 13-26
- Conformance to Standards, 2-2
- Connector carrier
 - cable types and wiring, 2-22
- Connector-Style I/O Carrier, 4-8, 4-20
- Control wiring, 2-11
- CPUs for VersaMax, 1-4

D

- DeviceNet Modules User's Manual, 1-2
- DIN rail mounting, 2-3
- Discrete Input Module IC200MDL140, 7-2
- Discrete input module IC200MDL141, 7-5
- Discrete Input Module IC200MDL143, 7-8
- Discrete input module IC200MDL144, 7-11
- Discrete input module IC200MDL240, 7-14
- Discrete input module IC200MDL241, 7-18
- Discrete input module IC200MDL243, 7-21
- Discrete input module IC200MDL244, 7-25
- Discrete input module IC200MDL631, 7-28
- Discrete input module IC200MDL632, 7-31
- Discrete input module IC200MDL635, 7-35
- Discrete input module IC200MDL636, 7-38
- Discrete input module IC200MDL640, 7-42
- Discrete input module IC200MDL643, 7-45
- Discrete input module IC200MDL644, 7-49
- Discrete input module IC200MDL650, 7-53
- Discrete input/output module IC200MDD840, 9-2
- Discrete input/output module IC200MDD842, 9-6
- Discrete input/output module IC200MDD843, 9-12
- Discrete input/output module IC200MDD844, 9-16
- Discrete input/output module IC200MDD845, 9-21
- Discrete input/output module IC200MDD846, 9-27

Index

Discrete input/output module IC200MDD847, 9-31
Discrete input/output module IC200MDD848, 9-35
Discrete input/output module IC200MDD849, 9-40
Discrete input/output module IC200MDD850, 9-44
Discrete input/output module IC200MDD851, 9-48
Discrete output module IC200MDL329, 8-2
Discrete output module IC200MDL330, 8-6
Discrete output module IC200MDL331, 8-10
Discrete output module IC200MDL730, 8-14
Discrete output module IC200MDL740, 8-17
Discrete output module IC200MDL741, 8-21
Discrete output module IC200MDL742, 8-25
Discrete output module IC200MDL743, 8-29
Discrete output module IC200MDL744, 8-32
Discrete output module IC200MDL750, 8-36

E

Ethernet NIU User's Manual, 1-2
Expansion cable
 installation, 2-7
Expansion cable length and data rate, 6-4, 6-9
Expansion cables IC200CBL601, 602, 615, 6-6
Expansion connector kit IC200ACC202, 6-6
Expansion modules
 catalog numbers, 1-15
Expansion Receiver Module
 installation, 2-6
Expansion Receiver Module (IC200ERM002), 6-11
Expansion Receiver Module, Isolated (IC200ERM001), 6-7
Expansion Transmitter Module, 6-2
 installation, 2-5

F

Field Power LED, 1-9

G

Genius NIU User's Manual, 1-2
Grounding, 2-15

H

High Speed Counter module, 13-2
Hot insertion, 1-3, 2-38

I

I/O carriers, 1-9
I/O Filler IC200ACC301, 15-2
I/O Modules
 catalog numbers, 1-11
IC200ACC201, 6-4, 6-6, 6-10, 6-15
IC200ACC202, 6-6, 6-10, 6-15
IC200ACC301, 15-2
IC200ACC302, 15-3
IC200ALG230, 10-2
IC200ALG240, 10-9
IC200ALG260, 10-17
IC200ALG261, 10-24
IC200ALG262, 10-29
IC200ALG263, 10-36
IC200ALG264, 10-42
IC200ALG320, 11-2
IC200ALG321, 11-9
IC200ALG322, 11-15
IC200ALG325, 11-21
IC200ALG326, 11-28
IC200ALG327, 11-34
IC200ALG328, 11-41
IC200ALG331, 11-48
IC200ALG430, 12-2
IC200ALG431, 12-9
IC200ALG432, 12-16
IC200ALG620, 14-2
IC200ALG630, 14-10
IC200BEM002, 1-18
IC200BEM103, 1-18
IC200BEM104, 1-2, 1-18
IC200CBL002, 6-5, 6-6, 6-10
IC200CBL105, 1-14, 2-20, 4-10
IC200CBL110, 1-14, 2-20, 4-10
IC200CBL120, 1-14, 2-20, 4-10
IC200CBL230, 1-14, 2-20, 4-10
IC200CBL601, 6-6, 6-10, 6-15
IC200CBL602, 6-6, 6-10, 6-15
IC200CBL615, 6-6, 6-10, 6-15
IC200CHS001, 4-2
IC200CHS002, 4-5
IC200CHS003, 4-8

IC200CHS005, 4-11
IC200CHS006, 4-20
IC200CHS011, 5-2
IC200CHS012, 5-4
IC200CHS014, 5-6
IC200CHS015, 5-8
IC200CHS022, 4-14
IC200CHS025, 4-17
IC200DBI001, 1-7
IC200EBI001, 1-7
IC200ERM001, 6-7
IC200ERM002, 6-11
IC200ETM001, 6-2
IC200GBI001, 1-7
IC200MDD840, 9-2
IC200MDD841, 13-2
IC200MDD842, 9-6
IC200MDD843, 9-12
IC200MDD844, 9-16
IC200MDD845, 9-21
IC200MDD846, 9-27
IC200MDD847, 9-31
IC200MDD848, 9-35
IC200MDD849, 9-40
IC200MDD850, 9-44
IC200MDD851, 9-48
IC200MDL140, 7-2
IC200MDL141, 7-5
IC200MDL143, 7-8
IC200MDL144, 7-11
IC200MDL240, 7-14
IC200MDL241, 7-18
IC200MDL243, 7-21
IC200MDL244, 7-25
IC200MDL329, 8-2
IC200MDL330, 8-6
IC200MDL331, 8-10
IC200MDL631, 7-28
IC200MDL632, 7-31
IC200MDL635, 7-35
IC200MDL636, 7-38
IC200MDL640, 7-42
IC200MDL643, 7-45
IC200MDL644, 7-49
IC200MDL650, 7-53
IC200MDL730, 8-14
IC200MDL740, 8-17
IC200MDL741, 8-21
IC200MDL742, 8-25

IC200MDL743, 8-29
IC200MDL744, 8-32
IC200MDL750, 8-36
IC200MDL930, 8-40
IC200MDL940, 8-44
IC200PBI001, 1-7
IC200TBM005, 5-21
Input Simulator IC200ACC302, 15-3
Interposing Barrier-Style I/O Terminals, 5-2
Interposing Box-Style I/O Terminals, 5-4
Interposing Thermocouple Compensation Box-Style I/O Terminals, 5-6

K

Keying, 2-36
Keying dials on carrier, 1-9
Keying summary, D-1

M

Manuals, 1-2
Mixed discrete module IC200MDD841, 13-2
Module color code, 1-9
Module dimensions, 1-9
Module installation, 2-37
Module keying, 1-9
Module latch, 1-9, 2-37
Module orientation on I/O carriers, 1-13
Modules per station, 1-3
MOV, 2-14

N

Network Interface Units for VersaMax, 1-6
NIU
 Devicenet, 1-7
 Ethernet, 1-7
 Genius, 1-7
 Profibus, 1-7
NIU serial port, 6-5

O

OK LED, 1-9

Index

P

- Power and Ground Wiring, 2-12
- Power Supplies, 1-8
 - IC200PWR001, 3-2
 - IC200PWR002, 3-4
 - IC200PWR101, 3-6
 - IC200PWR102, 3-8
 - IC200PWR201, 3-10
 - IC200PWR202, 3-12
- Power supply
 - installation, 2-9
- Power Supply Booster Carrier IC200PWB001, 4-21
- Power wiring, 2-11
- Profibus Modules User's Manual, 1-2

R

- Rack Selection Switch, 6-8
- Relay contact ratings, B-1
- Relay Output Module IC200MDL930, 8-40
- Relay Output Module IC200MDL940, 8-44

S

- Serial cable IC200CBL002, 6-5
- Serial numbers, 2-1
- Serial port
 - pass-through, 6-5
- Shipping damage, 2-1
- Shorting bar
 - installation, 2-34
- Specifications
 - IC200ALG230, 10-3
 - IC200ALG240, 10-10
 - IC200ALG260, 10-18
 - IC200ALG261, 10-25
 - IC200ALG262, 10-30
 - IC200ALG263, 10-37
 - IC200ALG264, 10-43
 - IC200ALG320, 11-3
 - IC200ALG321, 11-10
 - IC200ALG322, 11-16
 - IC200ALG325, 11-22
 - IC200ALG326, 11-29
 - IC200ALG327, 11-35
 - IC200ALG328, 11-42

- IC200ALG331, 11-49
- IC200ALG430, 12-3
- IC200ALG431, 12-10
- IC200ALG432, 12-17
- IC200ALG620, 14-4
- IC200ALG630, 14-12
- IC200ERM001, 6-10
- IC200ERM002, 6-15
- IC200ETM001, 6-6
- IC200MDD840, 9-3
- IC200MDD841, 13-5
- IC200MDD842, 9-7
- IC200MDD843, 9-13
- IC200MDD844, 9-17
- IC200MDD845, 9-22
- IC200MDD846, 9-28
- IC200MDD847, 9-32
- IC200MDD848, 9-36
- IC200MDD849, 9-41
- IC200MDD850, 9-45
- IC200MDD851, 9-49
- IC200MDL140, 7-3
- IC200MDL141, 7-6
- IC200MDL143, 7-9
- IC200MDL144, 7-12
- IC200MDL240, 7-15
- IC200MDL241, 7-19
- IC200MDL243, 7-22
- IC200MDL244, 7-26
- IC200MDL329, 8-3
- IC200MDL330, 8-7
- IC200MDL331, 8-11
- IC200MDL631, 7-29
- IC200MDL632, 7-32
- IC200MDL635, 7-36
- IC200MDL636, 7-39
- IC200MDL640, 7-43
- IC200MDL643, 7-46
- IC200MDL644, 7-50
- IC200MDL650, 7-54
- IC200MDL730, 8-15
- IC200MDL740, 8-18
- IC200MDL741, 8-22
- IC200MDL742, 8-26
- IC200MDL743, 8-30
- IC200MDL744, 8-33
- IC200MDL750, 8-37
- IC200MDL930, 8-41
- IC200MDL940, 8-45

IC200PWR001, 3-3
IC200PWR002, 3-5
IC200PWR101, 3-7
IC200PWR102, 3-9
IC200PWR201, 3-11
IC200PWR202, 3-13
System, 1-19
Spring-Style Auxiliary I/O Terminals, 5-21
Spring-Style I/O Carrier, 4-11
Spring-Style Interposing I/O Terminals, 5-8
Suppression, 2-14
System Wiring Guidelines, 2-11

T

Terminal Numbering, 2-17, 2-18, 2-19
Terminal Numbering for connector kit, 2-21
Terminator Plug IC200ACC201, 6-4, 6-6
Terminator plug not required for single-ended
installation, 6-13
Thermal Clearance, 2-2, A-2
Thermocouple Input Module, 14-10

V

VersaMax PLC User's Manual, 1-2

W

Wiring for I/O Devices, 2-16