

GFK-1476
New In Stock!
GE Fanuc Manuals

[http://www.pdfsupply.com/automation/ge-fanuc-manuals/operator-
interface/GFK-1476](http://www.pdfsupply.com/automation/ge-fanuc-manuals/operator-interface/GFK-1476)

operator-interface
1-919-535-3180

Datapanel Models K

www.pdfsupply.com

Email: sales@pdfsupply.com

GFK-1476
New In Stock!
~~GE Fanuc Manuals~~

<http://www.pdfsupply.com/automation/ge-fanuc-manuals/operator-interface/GFK-1476>

operator-interface
1-919-535-3180

Datapanel Models K

www.pdfsupply.com

Email: sales@pdfsupply.com

Datapanel

Operator Interface Products

Datapanel Models K, J+ and H

Operator's Manual

GFK-1476B

April 1999

Warnings, Cautions, and Notes as Used in this Publication

Warning

Warning notices are used in this publication to emphasize that hazardous voltages, currents, temperatures, or other conditions that could cause personal injury exist in this equipment or may be associated with its use.

In situations where inattention could cause either personal injury or damage to equipment, a Warning notice is used.

Caution

Caution notices are used where equipment might be damaged if care is not taken.

Note

Notes merely call attention to information that is especially significant to understanding and operating the equipment.

This document is based on information available at the time of its publication. While efforts have been made to be accurate, the information contained herein does not purport to cover all details or variations in hardware or software, nor to provide for every possible contingency in connection with installation, operation, or maintenance. Features may be described herein which are not present in all hardware and software systems. GE Fanuc Automation assumes no obligation of notice to holders of this document with respect to changes subsequently made.

GE Fanuc Automation makes no representation or warranty, expressed, implied, or statutory with respect to, and assumes no responsibility for the accuracy, completeness, sufficiency, or usefulness of the information contained herein. No warranties of merchantability or fitness for purpose shall apply.

Content of This Manual

This manual describes features, installation, and operation of the following Datapanel operator interface products:

Model K
Model J+
Model H

Revisions to this Manual

This revision includes the following changes:

- Removal of all information pertaining to Datapanel Models 320T and 240T (see GFK-1571).
- The Datapanel OI products feature a new enclosure design, which uses plastic clips instead of screws to secure the front and rear sections of the unit (chapter 4).
- Since the download cable is supplied with the Datapanel, the cable fabrication diagram previously included in chapter 4 is not needed and has been deleted.
- Other corrections and clarifications as required.

Related Publications

GFK-1475 *WinCfg User's Manual*

Chapter 1	Quick Start	1-1
	Mounting the Datapanel.....	1-1
	Connecting Cables.....	1-1
	Startup.....	1-1
	Viewing Other Pages	1-1
	Viewing Overview Groups	1-2
	Printing a Page.....	1-2
	Displaying Alarms.....	1-2
	Acknowledging Alarms	1-2
	Adjusting Display Attributes.....	1-2
	Setting the Time and Date Display.....	1-2
	Keypad Models.....	1-3
	Touch Models.....	1-3
	Modifying the Process	1-3
	Special Drive Out Capabilities	1-4
	Password Protection.....	1-4
Chapter 2	Introduction to the Datapanel Range.....	2-1
	Strong Commonality With Broad Range of Capabilities.....	2-1
	Configuration Software.....	2-2
	Industrial Housing	2-2
	Components of the System.....	2-3
Chapter 3	Overview of Datapanel Range	3-1
	Datapanel Model K.....	3-1
	Datapanel Model J+.....	3-2
	Datapanel Model H.....	3-3
	Minimum Customer Supplied Hardware	3-5
Chapter 4	Installing the Hardware	4-1
	Physical Characteristics	4-1
	Mounting Datapanel.....	4-2
	Connection Cables.....	4-3
Chapter 5	Operation Guide.....	5-1
	Overview.....	5-1
	Typical Operation Scenarios	5-3
	Routine Processing	5-3
	Viewing Other Pages	5-3
	Viewing Overview Groups.....	5-3
	Printing a Page.....	5-3
	Alarm Conditions	5-4
	Displaying Alarms.....	5-4
	Acknowledging Alarms	5-4

	Additional Alarm Information	5-4
	Modifying the Process	5-6
	Password Protection	5-6
	Selecting a Tag and Entering a Value.....	5-6
	Special Drive Out Capabilities	5-7
	Enhanced Drive Out.....	5-7
Chapter 6	Special Operations: Mode Menu	6-1
	Exit	6-1
	About Menu	6-2
	Display Control Menu	6-2
	Off-Line Mode	6-4
	Serial Ports Configuration.....	6-5
	Setting Time and Date Display.....	6-6
	Keypad Models	6-7
	All Models	6-7
	Host Transfer.....	6-8
	Enable/Disable Alarms	6-9
	Configuring Host Communications.....	6-9
Chapter 7	Specifications.....	7-1
	Hardware Specifications	7-1
	Display.....	7-1
	Backlight.....	7-1
	Keypad.....	7-2
	Keypad Models.....	7-2
	Technical Specifications	7-2
	Electrical Specifications.....	7-3
	Power Requirements.....	7-3
	Ports and Pinouts	7-4
	Datapanel K.....	7-4
	Model J+	7-5
	Datapanel H.....	7-6
	Data Retention.....	7-7
	Real-Time Clock	7-7
	Environmental Conformity	7-8
	Networking with Datapanel.....	7-8
Appendix A	Error Codes.....	A-1
	Standard Comms Block Error Codes.....	A-1
	System Error Codes	A-1
	Controller Errors.....	A-1
Appendix B	Glossary	B-1

Figure 4-1. Datapanel Mounting Clamps 4-2

Figure 5-1. Function Keys of Datapanel Models 5-2

Figure 5-2. Sample Alarm Logs 5-6

Figure 6-1. Mode Menu 6-1

Figure 6-2. About Menu 6-2

Figure 6-3. Display Control Menu 6-3

Figure 6-4. Off-Line Mode Menu 6-4

Figure 6-5. Set Ports Menu 6-5

Figure 6-6. Set Clock Menu 6-6

Figure 6-7. Host Transfer Display 6-8

Figure 6-8. Datapanel Configuration For Host Comms 6-9

Figure 6-9. Set Host Comm Menu 6-10

Figure 7-1. Model K Ports and Pinouts 7-4

Figure 7-2. Model J+ Ports and Pinouts 7-5

Figure 7-3. Model H Ports and Pinouts 7-6

Contents

Table 3-1. Summary of Datapanel Features and Capabilities.....	3-4
Table 4-1. Physical Dimensions and Panel Cutouts.....	4-1
Table 5-1. Alarm Log Characteristics	5-5
Table 7-1. Display Area and Characteristics	7-1
Table 7-2. Backlight Type	7-2
Table 7-3. Keypad Characteristics	7-2
Table 7-4. Technical Specifications	7-3
Table 7-5. Power Requirements.....	7-3
Table 7-6. Data Retention Characteristics	7-7
Table 7-7. Real-Time Clock Characteristics.....	7-7
Table 7-8. Environmental Conformity	7-8
Table 7-9. Test Specifications.....	7-8

Chapter 1

Quick Start

This section is provided as a simplified introduction and operation guide. See subsequent chapters for more detailed information and explanation.

Mounting the Datapanel

After positioning the Datapanel in the cutout, secure using the mounting clips supplied with the Datapanel.

Connecting Cables

Connect the PLC-Datapanel cable between the PLC and the Datapanel. Connect the Datapanel power.

Startup

On power-up, the Datapanel will enter Run Mode and begin normal operation. The Start Up page will be displayed if one was specified during configuration with the configuration software. Otherwise, page 0 containing the logo will be displayed. Two lines of display are reserved for system use. The top line displays a mini alarm log, a comms block error log, the date, and the time. The bottom line displays descriptive text for the function keys.

Viewing Other Pages

For a process that is running routinely, you would likely display a page which provides a good summary of process conditions. Other pages provide alternate views of the operation of the process. You can choose another page by typing in the page number and pressing  (ENTER). Alternatively, you can scroll through the pages by pressing the ▲ or ▼ keys.

Viewing Overview Groups

Press **OVERVIEW** to see a list of overview groups which were configured for your application. The list of groups is displayed in pages with 10 or 20 groups being listed on each page. Use <<< and >>> to move through the pages of the Overview list. Scroll through the pages of the Overview list until the required page is accessed. Use the ▲ or ▼ keys to select the required Overview Group from the displayed page. Press **TAGS** to display the tags and values associated with this group. You can return to the first page of the list at any time by pressing **OVERVIEW**.

Printing a Page

If the page being displayed has **PRINT** assigned to one of the F-keys, pressing that F-key will output the text content of the page to the printer.

Displaying Alarms

Press **ALARM LOG** to display the Alarm Log. When a tag exceeds its limits, it will remain in the Alarm Log until it has been acknowledged and returns to normal or until it has been overwritten by tags alarming at a later time in an overflowing alarm log. Three methods of showing unacknowledged alarms are used, depending on the Datapanel model: white text on black background, an asterisk to the left of the alarm, red text on color models.

Acknowledging Alarms

Press **ALARM ACK** to acknowledge an alarm. The first press of the key clears the global alarm bit. Typically, this bit is sent to the controller to silence the audible alarm. Subsequent presses of the key clear each alarm in turn, starting with the earliest of the alarms. Press the ▲ or ▼ keys to access other pages of the log.

Adjusting Display Attributes

Press **MODE** to display the Mode Menu. Press **DISPLAY (DISP** on Models J and K) to display the Display Control Menu. Press **INCREASE (INC** on Models J and K) or **DECREASE (DEC** on Models J and K) repeatedly to adjust the contrast to the desired level.

Press **ON** to turn the display backlight on, enter a number within the range of 0 to 99 minutes. If the Datapanel keyboard or touch screen is inactive longer than this period the display will be turned off. The display will be turned back on when any key is pressed. If zero is entered, the backlight will remain on at all times.

Press **EXIT** to return to the main Mode menu. Press **EXIT** to return to the displayed page.

Setting the Time and Date Display

Press **MODE** to display the Mode Menu. Press **OFF-L (OFF-LINE)** on Model H) to go off-line and display the Off-Line Mode menu. Press **CLOCK (SET CLOCK)** on Model H) to display the Set Clock menu.

Keypad Models

Press the up-down arrow keys (▲ ▼) to move from field to field on the display. Using the numeric keypad, type in the desired values for the field, press .

Touch Models

Press **SET** to access the pop-up screen touch numeric keypad. The active field is displayed at the top of the screen keypad. Press the up-down arrow keys (▲ ▼) to move from field to field on the display. Using the screen keypad, type in the desired values for each field in turn, press  on the screen or on the physical keypad.



Press **UPDATE** to confirm the entries, update the clock, and return to the main Off-Line Menu.

Or, press **EXIT** to abort the option and return to the main Off-Line Menu without changing the clock settings.

Press **EXIT** to return to the main Mode menu. Access the Run Mode by pressing **EXIT**.

Modifying the Process

An operator can modify the on-going process by using the Drive Out function of the Datapanel. This enables fresh values to be transmitted to any configured Drive Out tag. If a softkey has been configured for Drive Out, press that key to access the Drive Out function.

A list of tags available for Drive Out and their associated index numbers will appear on the display. Enter the index number using the numeric keypad or the numeric touch region. Press . (If an incorrect value is entered, the message, **bad input**, is displayed and the value must be re-entered.) Additional Drive Out tags may then be entered. Pressing  a second time, after a value has been transmitted, terminates the Drive Out option and the normal page will be displayed.

Special Drive Out Capabilities

Four types of Enhanced Drive Out can be configured: Toggle, Ramp, Jog, and Direct Write. If a tag with this capability is selected, the designation of the softkeys is re-assigned so that the user-defined labels for the toggle, ramp, jog, or direct-write functions will be displayed. On touch models, a special touch region may be displayed.

Toggle. Pressing the F-key or touch region defined for the toggle function will invert the value of the configured item. For example, this could be used to switch a valve from on to off.

Jog (aka Momentary). Pressing and holding the F-key defined for the function will continuously send a value (set or reset) to the configured item while the F-key is depressed. When the operator releases the F-key, the opposite value will be sent.

Ramp. Pressing the F-key or touch region defined for the ramp function will display the current value and allow this value to be modified by pressing the up-down arrow keys (▲ ▼). The new value is confirmed by pressing .

Direct Write. Pressing the F-key or touch region defined for the direct-write function will either:

1. Drive Out a preconfigured value.
2. Request operator input of a value to Drive Out.

Password Protection

Some functions may be protected at the time of configuration. If so, a prompt is displayed asking for the password. The correct password for the particular option must be entered in answer to the prompt. An incorrect password aborts the request.

Chapter 2

Introduction to the Datapanel Range

The Datapanel Range consists of a series of low-cost Human-Machine Interfaces enabling the transfer of data from a Programmable Logic Controller (PLC) and other intelligent control devices to a comprehensive operator terminal. Datapanel Range Operator Interfaces (OI) are an ideal replacement for discrete operator input and annunciation devices. Because of its many configurable options, a Datapanel can meet applications ranging from simple pushbutton replacement to complex interfaces beyond the capabilities of most small OIs.

Strong Commonality With Broad Range of Capabilities

With a uniform software and hardware architecture, Datapanel allow the user to produce an OI consistent with application budget and performance requirements while maintaining upgradeability. An expanding library of over 80 controller protocols is included with each Datapanel, meaning that a change in control hardware only requires reconfiguring communications and does not mean re-implementing the OI.

With a consistent architecture, Datapanel hardware is scaled to meet the cost and performance requirements of each particular model. That means application software can run on all models, providing extensive functionality on even the lowest price Datapanel. Application software makes Datapanel perform with efficiency. A wide range of applications software is built into every model.

An Operator Interface application is not restricted to emulating push buttons. Application software in Datapanel supports development of far more useful OI systems. Operator Interface software is included in every Datapanel. The software supports configuration of simple or complex OIs.

Standard features of all Datapanel models include:

- **Controller Communications.** Read and write data to the control equipment via a serial port.
- **Integrated Keypad.** Includes programmable function keys.
- **Broad Protocol Support.** Over 80 protocols supported.
- **Analog and Digital Tag Scaling.** Converts raw data to and from engineering units, and adds tag name information.

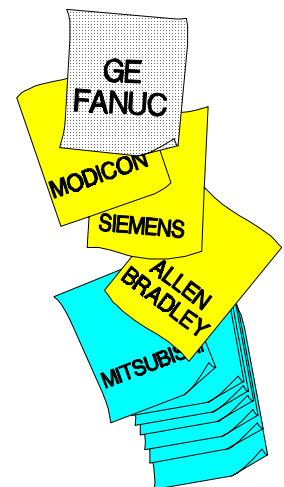

- **Display Real-Time Data.** Provide information on the current state of the plant process.
- **Optional Display Modes.** Continuous updates, update continuously only when page is displayed, update once when page is first displayed.
- **Alarm Manager.** Checks for analog and digital alarms, maintains a log of active alarms and supports operator acknowledgment of alarms.
- **Graphic Page Display.** Display static and dynamic text on up to 100 user configured pages per Datapanel. Up to 512 dynamic elements may be updated from the controller per page. Multiple font sizes allow for emphasis of important data.
- **Softkeys.** Six or eight keys per page, for up to 800 user defined buttons per Datapanel. Buttons may change pages, write data, or perform other OI functions.
- **Overview Display.** Predefined tabular display of Datapanel and controller data.
- **NEMA 4X/4/12 Rated.** Ruggedized for harsh industrial environments.
- **VT 100 supported.** Emulation for expanded capability.

Configuration Software

Configuration of a Datapanel is quick and easy. Datapanel feature a common software environment, which means that configuring for one model is just like configuring for another. That increases productivity and decreases the time required to bring a Datapanel on-line. WinCfg, a PC-based tool operating under Windows® is used to create a database for the Datapanel. The database and communications protocol are loaded to the Datapanel via a serial port, and the OI may then be put on-line. WinCfg is sold separately. A single copy of WinCfg can be used to configure any of the Datapanel Range. WinCfg requires a PC-compatible computer running either Windows 95®, Windows 98® or Windows NT®.

Industrial Housing

Datapanel are designed for use in demanding industrial applications. With over 15 years' experience in meeting the requirements of industrial users, Datapanel avoid the problems that can plague lesser-quality products. All hardware is designed to meet industrial application requirements. Datapanel are of compact, shallow design. All front external surfaces are sealed and protected to NEMA 4X/4/12 (IP65) standards against the penetration of water and foreign particles. (Model H is NEMA 4/12.) Datapanel are ideally suited for use as ruggedized panel-mounted units in harsh industrial environments.

Windows 95®, Windows 98®, and Windows NT® are registered trademarks of Microsoft Corporation.

Components of the System

A Datapanel system includes:

- 1 unit from the Datapanel Range, incorporating an LCD display screen and membrane keypad and/or touch screen

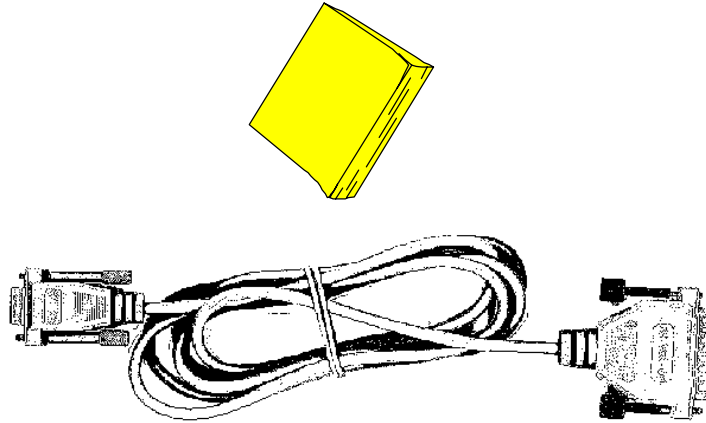

- 1 PC-to-Datapanel cable
- 1 Operator's Manual (this book)

Although Datapanel units are self-contained units, the use of a PC is necessary when configuring the system and when databases are being downloaded to the controller.

Chapter 3

Overview of Datapanel Range

A brief description of each of the Datapanel is given below. A summary of Datapanel features and capabilities is given in Chapter 2. Chapter 4 provides information on installing the Datapanel, Chapter 5 provides operational information, and Chapter 8 provides detailed specifications.

The range is made up of the following models:

Datapanel Models K and J+

The two entry level models - Model J+ has increased graphic functionality, real-time clock, two serial ports, and printing. Model K has no real-time clock and one serial port.

Datapanel Model H (Mark 2)

Physically the largest model in the Datapanel Range offering a bigger and brighter display area and greater functionality than the Models K and J+.

Datapanel Model K

The Model K is the lowest price Datapanel. It includes a 256 x 64 pixel display with function keys and numeric keypad. Variable text size is supported. The Model K can display 6 lines of 42 characters each when configured for the minimum text size of 6 pixel wide x 8 pixel high. The Model K is a good choice for push button replacement. With six user function keys available on each of 100 pages, up to 600 push buttons can be defined.

The powerful runtime software which is standard on all Datapanel makes the Model K even more functional. Use it to manage alarms, report diagnostic information and enter operator data.



Datapanel Model J+

Identical in size and appearance to the Model K, the Datapanel Model J+ offers enhanced functionality at an affordable price. A second serial port may be used to print alarm messages and reports, providing a hard copy of all system events. Optional Host Communications software is available to connect the Model J+ via the second port to a host computer or to other Datapanels. An extensive list of protocols is supported, making the Datapanel compatible with many supervisory products. An on-board real-time clock is used to accurately time stamp all system events. Through the runtime software, the clock may be used to synchronize the controller time. Optional software for the Model J+ includes VT 100 emulation. .



Datapanel Model H

For information intensive applications, the Datapanel Model H is the choice. With a 640x200 pixel LCD display and a larger keypad, the Model H has the capacity to manage a large amount of information.

Standard and Optional runtime software is identical to that offered on the Model J+, but the larger screen and more powerful processor means that the Model H can meet the requirements of large applications.

The Model H is housed in a rugged machined aluminum enclosure, and may be coated to meet hazardous environment requirements.

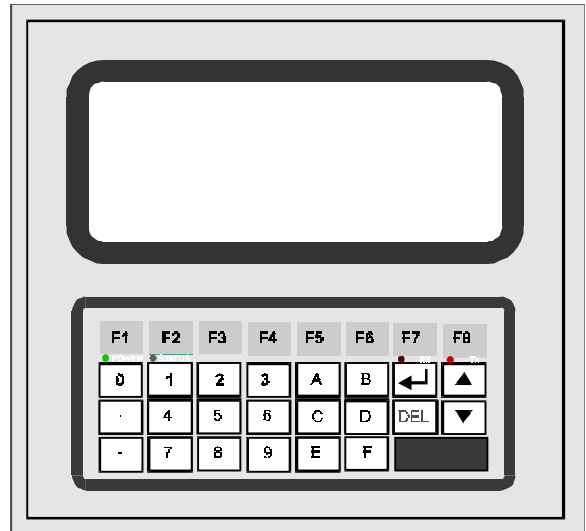

Table 3-1. Summary of Datapanel Features and Capabilities

Features	Model K	Model J+	Model H
Processor	NEC V20-10MHz	NEC V20-10MHz	NEC V40-16MHz
LCD Display Size (pixels)	256x64	256x64	640x200
mm (in.)	124 x 35 mm (4.88 x1.38 in.)	124 x 35 mm (4.88 x1.38 in.)	210.8 x 78.7 mm (8.3 x 3.1 in.)
Display capability with minimum text size	42 char 6 lines	42 char 6 lines	80 char 12 lines
Minimum Text Size (pixels)	6w x 8h	6w x 8h	8w x 14h
Database Size	64k	64k	64k
Backlight	EL	EL	CCFT
Memory, Flash	256KB Flash	256KB Flash	512KB Flash
Memory, SRAM or DRAM	128KB SRAM	128KB SRAM	128KB SRAM
Serial Ports	1 RS232	2 RS232	2 RS232/485
Additional Ports	No	No	No
Standard Software Features	Tag Scaling, Static and Dynamic data display, Alarm Manager, Read/Write to controller, Overview Display, Configurable Function Keys, Downloadable Database and Protocol, Variable text sizes		
Bar Graphs	No	Yes	Yes
Bitmap Graphics	No	Yes	Yes
Real-Time Trends	No	Option	Option
Host Comms	No	Option	Option
VT 100 Emulation	Option	Option	No
PC104 Expansion	No	No	No
Function Keys per Page	Six	Six	Eight
Data Entry Keypad	22 keys	22 keys	30 keys
Touch Screen	No	No	No
Controller Protocols	Over 80 supplied, including GE Fanuc, Modicon, Allen Bradley, Square D, Mitsubishi, Omron, Siemens, Idec etc. Call for details.		
Analog Tags	500	500	500
Digital Tags (2 bits per tag)	500	500	500
Display Pages	100	100	100
NEMA, UL, CUL, CE	4X/4/12, UL, CUL, CE	4X/4/12, UL, CUL, CE	4/12, UL, CUL, CE
Environmental	0 to +40 Deg C Operating Temp		
Dimensions (Inches)	8.19 Wide x 7.40 High x 1.81 Deep	8.19 Wide x 7.40 High x 1.81 Deep	12.20 Wide x 10.50 High x 1.80 Deep
Weight (lb.)	1.75	1.75	8.5
Panel Cutout (Inches)	7.75 W x 6.97 H	7.75 W x 6.97 H	11.5W x 9.8H
Power Input	9-35VDC, 24V AC (350 mA @9VDC)	9-35VDC, 24V AC (350 mA @9VDC)	9-35 VDC (600 ma @9VDC)

Minimum Customer Supplied Hardware

A PC or equivalent, running Windows, is required to configure Datapanel and transfer databases and protocol to the Datapanel:

- 486 DX2/66
- 8 MB RAM
- VGA Color Display
- 10 MB Hard Disk Space

Chapter 4

Installing the Hardware

Physical Characteristics

Datapanel are housed in two molded enclosures forming the front and the rear sections of the unit. The front section of models K and J+ form a bezel with a large central aperture giving access to the LCD display and to the membrane keypad. With the Model H, the front section bezel has two apertures, the upper aperture housing the LCD display and the lower one housing the keypad of the unit. The system hardware is mounted to the rear section with a gasket located between the front and rear sections to ensure conformity with IP65 (NEMA 4X/4/12) rating. (Model H is 4/12.) The rear section of the housing is a simple cover designed to fully enclose the system hardware. The two sections are secured to one another by snapping them together; the four plastic clips (one located near each corner) should fully latch to one another. The physical dimensions and the required panel cutouts are shown in Table 4-1.

Table 4-1. Physical Dimensions and Panel Cutouts

Features	Model K	Model J+	Model H
Dimensions (Inches)	8.19 Wide x 7.40 High x 1.81 Deep	8.19 Wide x 7.40 High x 1.81 Deep	12.20 Wide x 10.50 High x 1.80 Deep
Panel Cutout (Inches)	7.75 W x 6.97 H	7.75 W x 6.97 H	11.5W x 9.8H I

Mounting Datapanel

The Datapanel comes with a gasket glued in place on the bezel to ensure compliance with protection ratings. The Datapanel is secured using miniature screw clamps. The mounting points for the clamps are located on the front section of the Datapanel. Access to the rear of the unit is necessary so that clamps can be fitted.

After positioning the Datapanel in the cutout, the unit is then secured using the spring clamps as shown in Figure 4-1. Working from the rear of the panel, the clips must be located in the slots shown in the diagram and marked A. The clamps should be tightened evenly so as to cause the nuts to rise up the screw threads and thus close the springs. It is important that the screws are not over-tightened as the springs may then be deformed resulting in an improper mounting of the Datapanel.

A total of six clamps are used to secure Models J+ and K. Eight heavy duty clamps are used to secure the Model H.

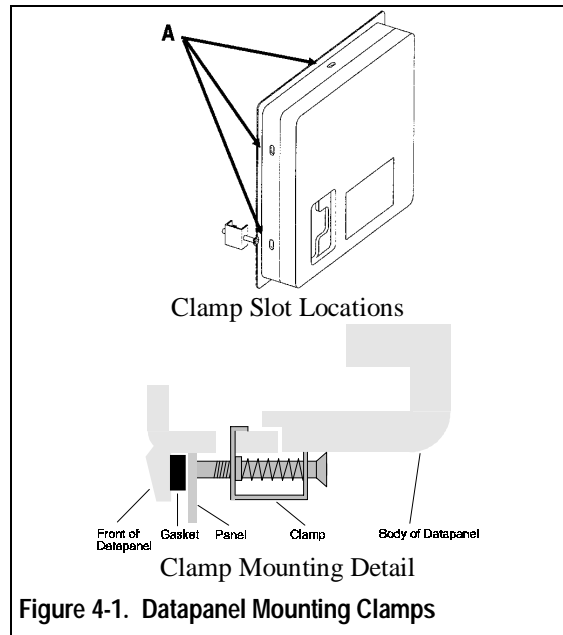

Figure 4-1. Datapanel Mounting Clamps

Connection Cables

Two connecting cables are required when using the Datapanel:

- The download cable is used when transferring databases or protocols from the configuration software to the Datapanel. The cable enables connection to a standard PC. For non-standard PCs; consult the PC manual to check the pin configuration at the PC end of the cable. This cable is supplied with the Datapanel.
- The cable used to connect Datapanel to the controller: As a general guide, the only pin connections required at the Datapanel end are Tx, Rx, Signal, Ground; with RTS connected to CTS. Refer to your controller documentation for details of connections at the controller end. This cable is not supplied with the Datapanel.

Chapter 5

Operation Guide

Overview

Datapanel operate in one of two modes:

- Run Mode - enables real time processes to be viewed from configured displays downloaded to Datapanel.
- Off-line - enables the configuring of the communications port, setting the date and time, loading databases and protocols, and enabling or disabling alarm checking.

On power-up, the Datapanel will enter Run Mode and begin normal operation. The Start Up page will be displayed if one was specified during configuration with the configuration software. Otherwise, page 0 containing the Datapanel logo will be displayed. The screen layouts of all Datapanel are similar in appearance, but vary slightly according to the capabilities of the various models. Two lines of display are reserved for system use. The top line displays a mini alarm log, a comms block error log, the date, and the time as shown in Figure 5-1.

The bottom line displays descriptive text for the function keys. One of the obvious differences between models is the number and location of the function keys (F-keys) - eight keys on the Model H, six on Models K and J+. The keys shown are the default configuration. Any of the keys may be assigned other labels and functions during configuration with the configuration software. They may have different labels and functions on different display pages. When the keys are reprogrammed from their default value, they are often referred to as *softkeys*.

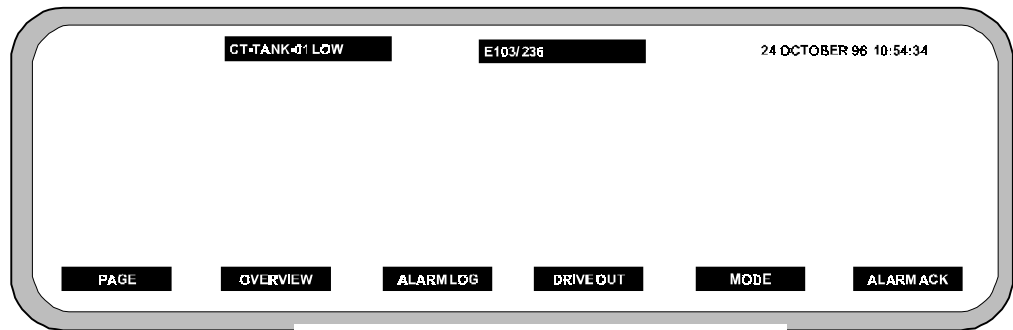

Function Keys on Models K and J

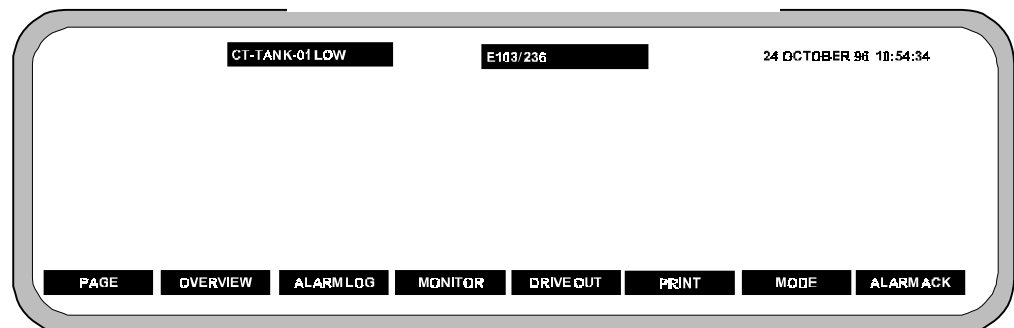

Function Keys on Model H

Figure 5-1. Function Keys of Datapanel Models

The default Run Mode F-keys are:

- **PAGE** - displays configured pages. Often, the first page is configured as an index or menu of all other pages.
- **OVERVIEW** - displays configured overview groups.
- **ALARM LOG** - displays the alarm log.
- **DRIVE OUT** - allows the operator to write to the controller.
- **PRINT** (Model H only) - allows the operator to obtain a printed output.
- **MODE** - allows the operator to switch between the Run Mode and Off-line.
- **ALARM ACK** - allows the operator to acknowledge alarms.

Typical Operation Scenarios

Routine Processing

For a process that is running routinely, you would likely display a page which provides a good summary of process conditions. The page might include a trend chart showing performance over some time period, a bar chart showing the availability of a critical process supply, and other elements showing constantly updating values of parameters indicating process efficiency (e.g., cans filled per hour, gallons of fruit juice per minute, kW of electricity consumed.)

Viewing Other Pages

Other pages provide alternate views of the operation of the process. For instance, this would be useful if you noticed a change in some parameter and you wanted more detail on that aspect of the process. You can choose another page by typing in the page number and pressing  (ENTER). Alternatively, you can scroll through the pages by pressing the ▲ or ▼ keys. The ▼ key displays the next page; the ▲ key displays the previous page. The logo page or the Start Up page will appear when you press **PAGE**. If so configured by the configuration software, the Start Up page may show a list or menu of other pages. If so configured, you can use a re-defined F-key or a touch region to access other pages.

Viewing Overview Groups

Press **OVERVIEW** to see a list of overview groups which were configured for your application. Each group contains a maximum of 10 configured tags which have been grouped together during configuration because they are relevant to each other, e.g., temperatures or pressures. There may be up to 100 groups. The list of groups is displayed in pages with 10 or 20 groups being listed on each page. When the **OVERVIEW** key is pressed, the designation and function of some of the softkeys change. For instance, one of the F-key labels displays a left-chevron design (<<<) and another displays a right-chevron design (>>>).

Use <<< to move backwards through the pages of the Overview list. Use >>> to move forward through the pages of the Overview list. Scroll through the pages of the Overview list until the required page is accessed. The range of Overview Groups on a particular page of the list is shown at the top of the display. Use the ▲ or ▼ keys to select the required Overview Group from the displayed page. Press **TAGS** to display the tags and values associated with this group. You can return to the first page of this list at any time by pressing **OVERVIEW**.

Printing a Page

If the page being displayed has **PRINT** assigned to one of the F-keys, pressing that F-key will output the text content of the page to the printer. For instance, you may want to do this at the end of a shift in order to have a permanent record of conditions at that time. Graphics on the page will not be printed.

Alarm Conditions

If one of the configured tags exceeds its limits, an alarm message will appear in the mini alarm log window and be added to the alarm log. Press the **ALARM ACK** F-key or touch region to acknowledge the alarm(s).

Displaying Alarms

Press **ALARM LOG** to display the Alarm Log. Sample alarm logs are shown in Figure 5-2.

The capacity and display characteristics of the logs depend on the Datapanel type and are described in the table below. If the capacity of the log is exceeded, the earlier alarms will be lost. When a tag exceeds its limits, it will remain in the Alarm Log until it has been acknowledged and returns to normal or until it has been overwritten by tags alarming at a later time in an overflowing alarm log. Two methods of showing acknowledged alarms are used:

Model H: Unacknowledged alarms are displayed in white text on a black background. Acknowledged alarms are displayed using black text on a white background.

Models K and J+: Unacknowledged alarms are indicated with an asterisk.

Acknowledging Alarms

Press **ALARM ACK** to acknowledge an alarm. The first press of the key clears the global alarm bit. Typically, this bit is sent to the controller to silence the audible alarm. Subsequent presses of the key clear each alarm in turn, starting with the earliest of the alarms. Press the ▲ or ▼ keys to access other pages of the log.

Additional Alarm Information

If the Datapanel has been configured to do so, selected alarms will be printed automatically as they occur. The mini alarm log shows the earliest unacknowledged alarm. The mini alarm log is updated as each alarm is acknowledged. When all alarms have been acknowledged, the mini alarm log is removed until another alarm condition occurs.

The **ALARM LOG** function key is displayed only if alarms are enabled. If the alarms were configured disabled or have been disabled in the Off-line option, the **ALARM LOG** and **ALARM ACK** function keys will be displayed blank.

Table 5-1. Alarm Log Characteristics

	Model K	Model J+	Model H
Alarm Capacity	50	50	50
Alarms/Page	5	5	10
Mini Alarm Log	10 characters of tag name	10 characters of tag name	16 characters of tag name
ACK method	* in ACK symbol column means not acknowledged	* in ACK symbol column means not acknowledged	reverse video means not acknowledged
ANALOG ALARMS			
1 st Column	ACK symbol	ACK symbol	not used
2 nd Column	10 characters of tag name	10 characters of tag name	16 characters of tag name
3 rd Column	4 characters of alarm type	4 characters of alarm type	6 characters of alarm type
4 th Column	10 characters of value	10 characters of value	10 characters of value
5 th Column	5 characters of units	5 characters of units	5 characters of units
6 th Column	8 characters of time	8 characters of time	8 characters of time
7 th Column	not used	not used	7 characters of date
DIGITAL ALARMS			
1 st Column	ACK symbol	ACK symbol	not used
2 nd Column	10 characters of tag name	10 characters of tag name	16 characters of tag name
3 rd Column	4 characters of alarm type	4 characters of alarm type	6 characters of alarm type
4 th Column	16 characters of status	16 characters of status	16 characters of status
5 th Column	not used	not used	not used
6 th Column	8 characters of time	8 characters of time	8 characters of time
7 th Column	not used	not used	7 characters of date

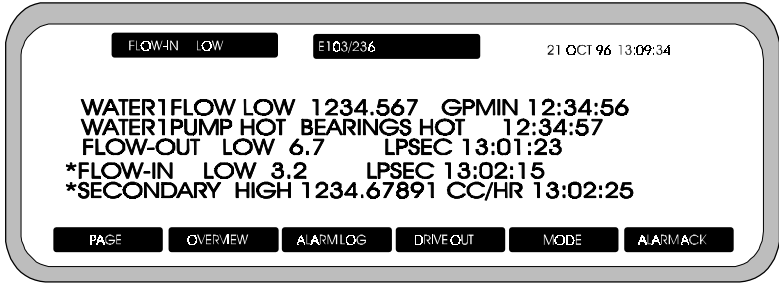

Alarm Log On Models K and J+

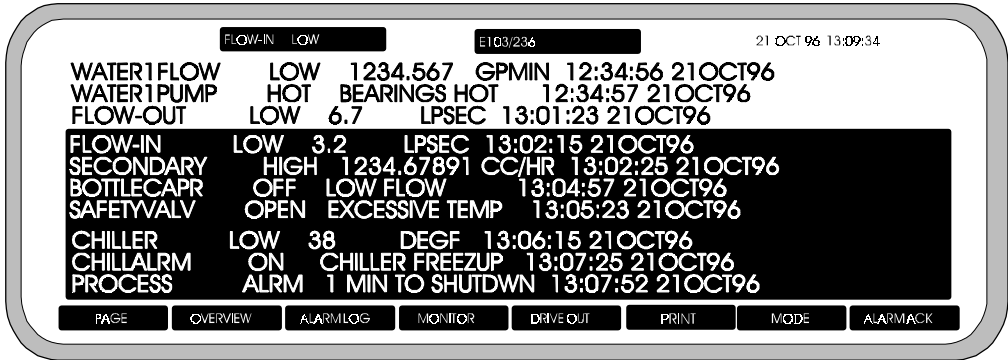

Alarm Log On Model H

Figure 5-2. Sample Alarm Logs

Modifying the Process

An operator can modify the on-going process by using the Drive Out function of the Datapanel. This enables fresh values to be transmitted to any configured Drive Out tag. If a softkey has been configured for Drive Out, press that key to access the Drive Out function.

Password Protection

The Drive Out function is usually password protected at the time of configuration. If so, when Drive Out is attempted, a prompt is displayed asking for the password. As there are three Drive Out options, three Drive Out passwords may have been configured, referenced to which display you have on the screen when you request Drive Out: Page, Monitor, and Overview. The correct password for the particular option must be entered in answer to the prompt. An incorrect password aborts the request. The Drive Out procedure is largely the same for each of the three options.

Selecting a Tag and Entering a Value

A list of tags available for Drive Out and their associated index numbers will appear on the display. Enter the index number using the numeric keypad or the numeric touch region. Press . (If an incorrect value is entered, the message, **bad input**, is displayed and the value must be re-entered.)



Additional Drive Out tags may then be entered. Pressing  a second time, after a value has been transmitted, terminates the Drive Out option and the normal page will be displayed.

Special Drive Out Capabilities

Enhanced Drive Out

Four types of Enhanced Drive Out can be configured: Toggle, Ramp, Jog, and Direct Write. If a tag with this capability is selected, the designation of the softkeys is re-assigned so that the user-defined labels for the toggle, ramp, jog, or direct-write functions will be displayed. On touch models, a special touch region may be displayed.

Toggle. Pressing the F-key or touch region defined for the toggle function will invert the value of the configured item. For example, this could be used to switch a valve from on to off.

Ramp. Pressing the F-key or touch region defined for the ramp function will display the current value and allow this value to be modified by pressing the up-down arrow keys ( ). The new value is confirmed by pressing .

Jog (aka Momentary). Pressing and holding the F-key defined for the function will continuously send a value (set or reset) to the configured item while the F-key is depressed. When the operator releases the F-key, the opposite value will be sent.

Direct Write. Pressing the F-key or touch region defined for the direct-write function will either:

1. Drive Out a preconfigured value.
2. Request operator input of a value to Drive Out.

Chapter 6

Special Operations: Mode Menu

The Mode menu is normally not used during routine operation of the Datapanel. It allows the operator to display information about the Datapanel, change the attributes of the display, or operate the Datapanel in the off-line mode. Press **MODE** to display the Mode Menu.

Mode Options - Model H (Mk 2)

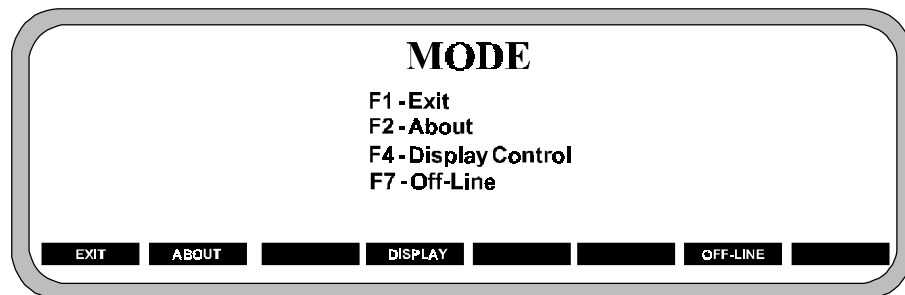

Mode Options - Models K, J+

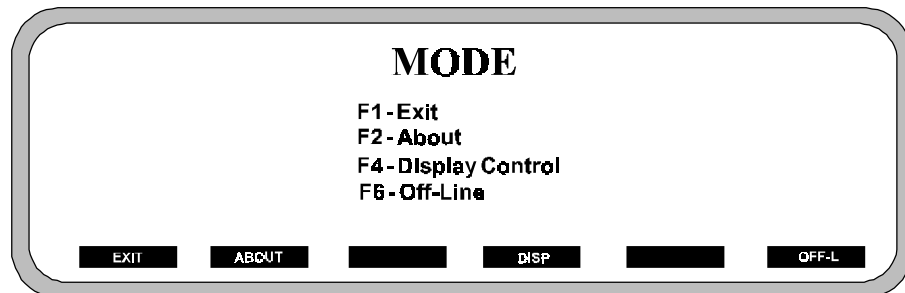

Figure 6-1. Mode Menu

Exit

Press **EXIT** to return to the startup page.

About Menu

Press **ABOUT** to display information about the Datapanel as shown in Figure 6-2. This information cannot be edited. Press **MORE** to display the configuration of the port settings. Press **EXIT** to return to the main Mode menu.

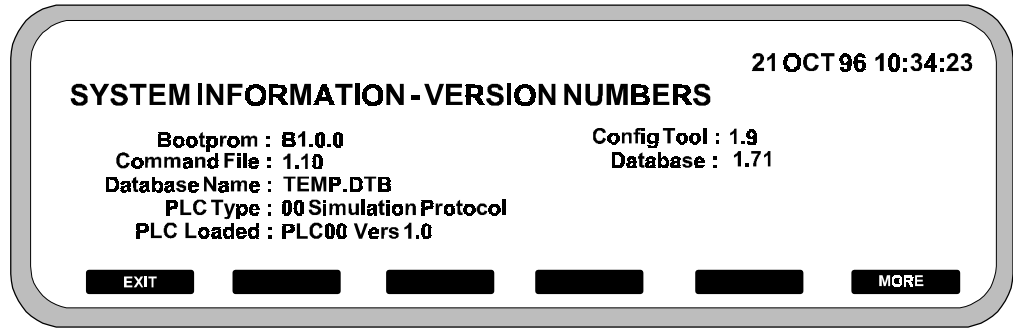
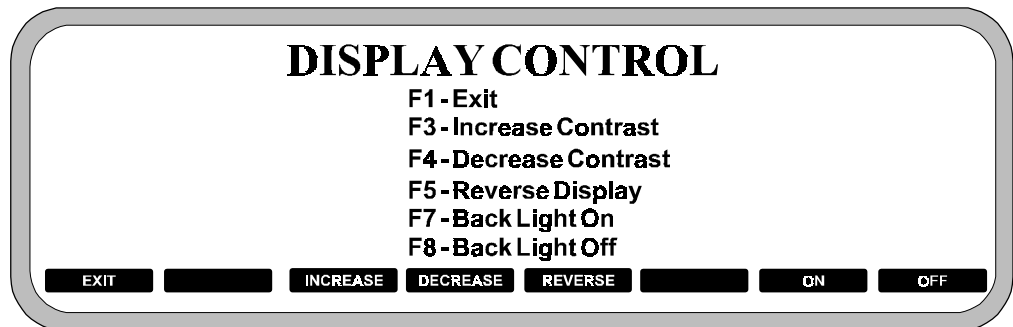

Figure 6-2. About Menu

Display Control Menu

Press **DISP** (**DISPLAY** on Model H) to view the Display Control Menu, shown in Figure 6-3. This menu allows the operator to change the display contrast setting, reverse the display, or to switch the backlight on or off. Unless the backlight is configured OFF with WinCfg, the default is ON.



Display Control Options - Model H

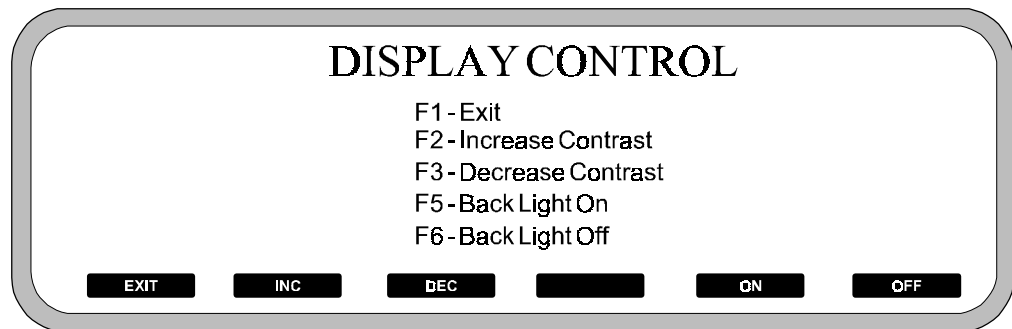

Display Control Options - Models K and J+

Figure 6-3. Display Control Menu

Press **INC (INCREASE)** on Model H) repeatedly to increase the contrast to the desired level.

Press **DEC (DECREASE)** on Model H) repeatedly to decrease the contrast to the desired level.

Press **REVERSE** (Model H only) to toggle the display between white text on a black background and black text on a white background.

Press **ON** to turn the display backlight on. The Datapanel will display the prompt:

Enter delay period in minutes -

If you want the display to be turned off after a period of inactivity, enter a number within the range of 0 to 99 minutes. If the Datapanel keyboard or touch screen is inactive longer than this period the display will be turned off. The display will be turned back on when any key is pressed. If zero is entered, the backlight will remain on at all times.

On Models K and J+, enter the time period using the numeric keypad.

Press **OFF** to turn the backlight off. This should be done in environments where the backlight is not needed in order to conserve power and extend the life of the backlight fluorescent tube in the Model H.

Press **EXIT** to return to the main Mode menu.

Off-Line Mode

The **Off-line** mode enables the operator to configure the communications port, set the date and time, load databases and protocols, and enable or disable alarm checking. When the Off-Line option is accessed, all controller communications and alarms are inactive and the mini alarm log is not displayed. The real time clock is not displayed but is running as a background task.

This function is usually password protected at the time of configuration. If so, when Off-Line is attempted, a prompt is displayed asking for the password. The correct password must be entered in response to the prompt. An incorrect password aborts the attempt to go off-line.

Press **OFF-L (OFF-LINE)** on Model H) to go off-line and display the Off-Line Mode menu shown in Figure 6-4. When finished, Press **EXIT** to return to the main Mode menu. The system will revert to the main Mode Menu but will remain Off-line until Run Mode is accessed by pressing **EXIT**. The clock and the mini alarm log will again display.

Off-Line Mode - Model H (Mk 2)

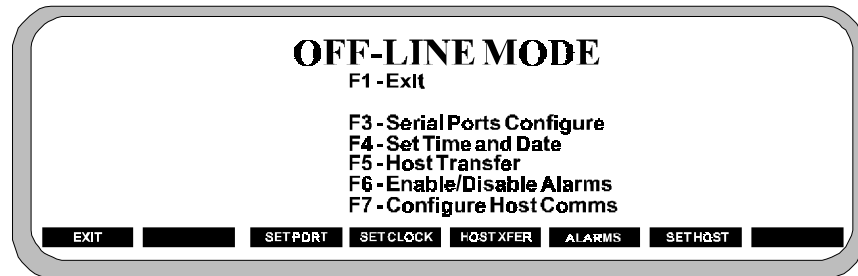

Off-Line Mode - Models K, J+

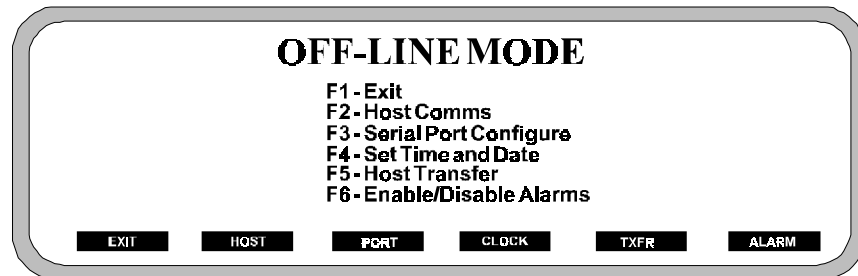
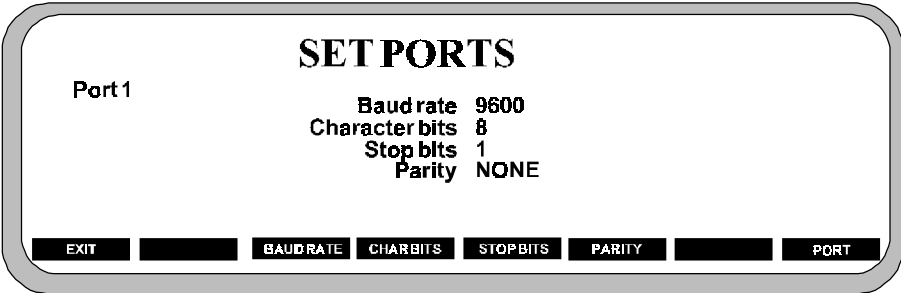

Figure 6-4. Off-Line Mode Menu

Serial Ports Configuration

Press **PORT** (**SET PORT** on Model H) to display the Set Ports Menu shown in Figure 6-5. This option also enables the display and modification of the configured settings for Port COM1 and Port COM2, if present. When finished, press **EXIT** to return to the Off-Line Mode menu.

Set Ports - Model H (Mk 2)



Set Ports - Models K, J+

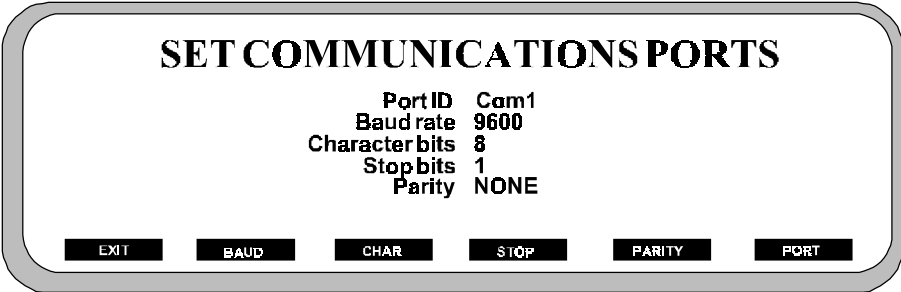

Figure 6-5. Set Ports Menu

- Press **PORT** to toggle between COM1 and COM2 to select the desired port.
- Press **BAUD RATE** repeatedly to scroll through the available baud rates to select the desired rate.
- Press **CHAR BITS** repeatedly to toggle between 7 and 8 to select the desired number of character bits.
- Press **STOP BITS** repeatedly to toggle between 1 and 2 to select the desired number of stop bits.
- Press **PARITY** repeatedly to scroll through the available parity choices to select the desired parity.
- Press **EXIT** to return to the Off-Line Mode menu.

Setting Time and Date Display

Press **CLOCK** (**SET CLOCK** on Model H) to display the Set Clock menu shown in Figure 6-6.

Set Clock - Model H (Mk 2)



Set Clock - Models K and J+

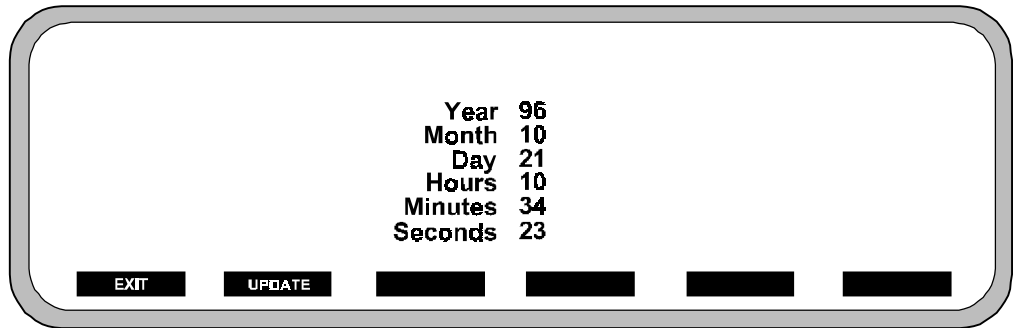



Figure 6-6. Set Clock Menu

Keypad Models

Press the up-down arrow keys (▲▼) to move from field to field on the display. Using the numeric keypad, type in the desired values for the field, press .

All Models

Press **UPDATE** to confirm the entries, update the clock, and return to the main Off-Line Menu.

Press **EXIT** to abort the option and return to the main Off-Line Menu without changing the clock settings.

Host Transfer

Press **TXFR** (**HOST XFER** on Model H) to access the Host Transfer display and enable data transfer between the Datapanel and the WinCfg PC. To exit the transfer, press **ABORT**

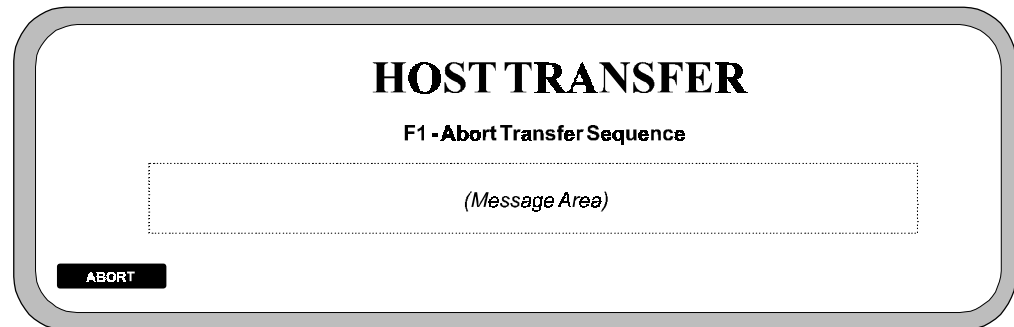

Display for Host Transfer

Figure 6-7. Host Transfer Display

The actual transfer of the data is under the control of the PC. The following messages will be displayed in the message area of the display:

When downloading a Protocol:

Loading Communications Protocol ...
and on the same line when complete, **Protocol installed.**

When downloading a Database:

Loading Database ...
and on the same line when complete, **Database installed.**

When uploading a Database:

Uploading Database ...
and on the same line when complete, **Database transferred.**

When a communications error occurs:

Transfer Failed

Enable/Disable Alarms

Press **ALARM** (**ALARMS** on Model H) to access the alarm option. The label of one of the F-keys will change to **ENABLE**, another will change to **DISABLE**. Press **ENABLE** to enable alarms. Press **DISABLE** to disable alarms. Press **EXIT** to return to the Off-Line Menu. This option is useful to prevent excessive alarm logging during periods of operation with known process discrepancies or during process testing.

Configuring Host Communications

If the Datapanel was purchased with the Host Comms, the printer port on the Datapanel can be used for communicating with another Datapanel. The required configuration is shown in Figure 6-8. Datapanel #1 is connected to the controller via its comm port. The printer port on Datapanel #1 is connected to the comm port on Datapanel #2. With Host Comms enabled on Datapanel #1, Datapanel #2 can now indirectly communicate with the controller, using Datapanel #1 as an intermediary. Datapanel #1 and Datapanel #2 can be configured with different displays, alarms, etc. The Host Comms option is available on all models in the Datapanel Range except for Model K. The device shown as Datapanel #2 can be any device which is compatible with the HOST COMM communication protocol, Modbus RTU.

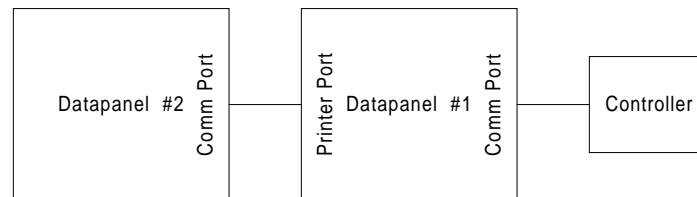

Configuration for Using Host Comm

Figure 6-8. Datapanel Configuration For Host Comms

When Host Comms is enabled:

- the values entered in the Datapanel Printer Port for Datapanel #1 must be compatible with the comm port settings for Datapanel #2.
- a Node ID for Datapanel #1 must be entered.
- no print facilities are available for Datapanel #1 but print facilities can be implemented on Datapanel #2.
- all alarm printing is disabled unless it is done through Datapanel 2.

Press **HOST** to display the Set Host Communications menu shown in Figure 6-9. (This function is not available on the Model K.) If the Host Comms option is not installed, the message screen shown in Figure 6-9 will appear.

Press **MODE** (**STATUS** on Model H) to toggle between enabled and disabled to select the desired mode. When Host Comms is enabled, a unique Node Identity must be assigned to the Datapanel #2. Press **<NODE** or **NODE>** to scroll through the possible total of 256 Node IDs to select the desired ID. Use the **<<<NODE** and **NODE>>>** keys to increment in steps of 10.

Press **EXIT** to accept the data and return to the main Off-Line Menu. Press **QUIT** to abort the option and return to the main Off-Line Menu without changing the settings.

Figure 6-9. Set Host Comm Menu

Set Host Comms - Model H (Mk 2)

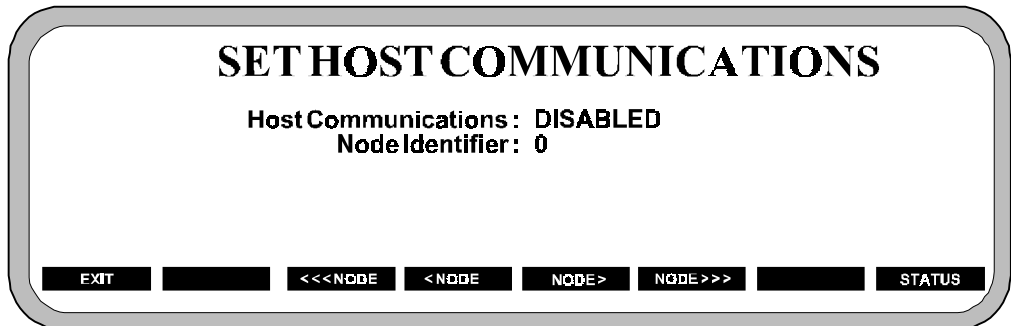

Set Host Comms - Model J+

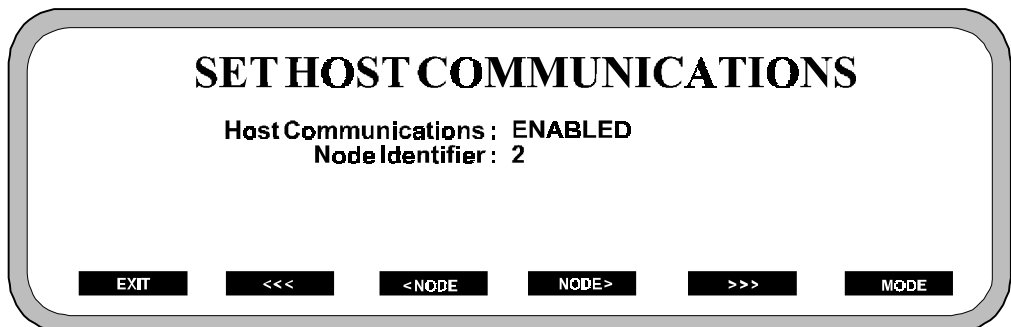

Message which appears if the Host Comm option was not purchased:

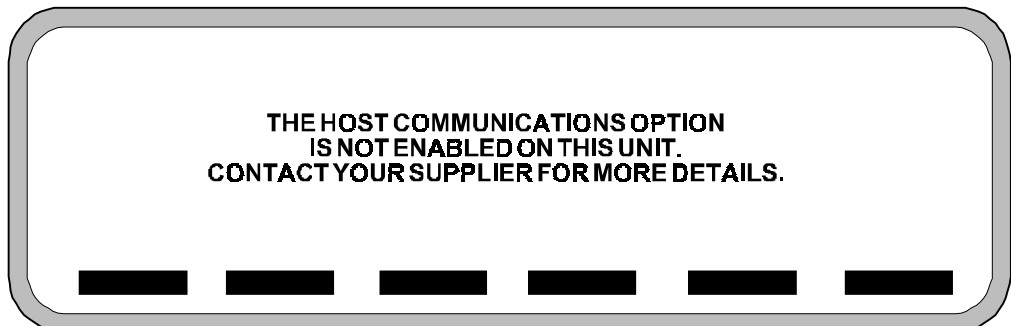

Chapter 7

Specifications

Hardware Specifications

Display

Text can be displayed in a variety of sizes by changing the height and width of the text. The default size is displayed with a height and width of 1 x 1 (see table below for pixel relationships). This can be increased so that text of 4 x 4 size can be configured. Two lines of the display are reserved for system use. The top line displays the date and time and any communications errors. The bottom line displays descriptive text for the function keys. The display area and display characteristics of the models in the are specified in Table 7-1.

Table 7-1. Display Area and Characteristics

Features	Model K	Model J+	Model H
LCD Display Size (pixels)	256x64	256x64	640x200
mm (in.)	124 x 35 mm (4.88 x1.38 in.)	124 x 35 mm (4.88 x1.38 in.)	210.8 x 78.7 mm (8.3 x 3.1 in.)
Display capability with minimum text size	42 char 6 lines	42 char 6 lines	80 char 12 lines
Minimum Text Size (pixels)	6w x 8h	6w x 8h	8w x 14h

Backlight

The backlight type is given in Table 7-2. The backlight of the display can be switched ON or OFF on all models in the Datapanel Range. Operation of the backlight is defined during configuration by the configuration software. In addition, the operator can control the backlight using the membrane key pad.

Table 7-2. Backlight Type

Features	Model K	Model J+	Model H
Backlight	EL	EL	CCFT

Keypad

All Datapanel incorporate built-in membrane keypads with audible feedback as described in Table 7-3.

Table 7-3. Keypad Characteristics

Features	Model K	Model J+	Model H
Function Keys per Page	Six	Six	Eight
Data Entry Keypad	22 keys	22 keys	30 keys
Touch Screen	No	No	No

Keypad Models

The top row of keys is the function keys required for the operation of the system. They match the keys displayed on the bottom line of the display. The remaining keys on Models K and J+ enable the input of numerical values. On Model H, an additional 6 alpha keys are available.

Technical Specifications

The technical specifications are given in Table 7-4.

Table 7-4. Technical Specifications

Features	Model K	Model J+	Model H
Processor	NEC V20-10MHz	NEC V20-10MHz	NEC V40-16MHz
Memory, Flash	256KB Flash	256KB Flash	512KB Flash
Memory, SRAM or DRAM	128KB SRAM	128KB SRAM	128KB SRAM
Database Size	64k	64k	64k
Serial Ports	1 RS232	2 RS232	2 RS232/485
Additional Ports	No	No	No

Electrical Specifications

Power Requirements

The power requirements are given in Table 7-5. The steady state current consumption of the Datapanel is dependent on the supply voltage. At power-up, the Datapanel briefly requires a larger current to operate correctly. To ensure correct power-up, the external power supply must be able to provide a current of at least 1 A, irrespective of the supply voltage.

The power for these Datapanel can be supplied either through the 4-pin power connector or through pins 14 - 17 on the 25-pin connector. However, pins 14 - 17 are intended only as a secondary power input option for end-users wishing to supply power from the controller. It is recommended that power be supplied via the dedicated input connector.

Table 7-5. Power Requirements

Features	Model K	Model J+	Model H
Power Input	9-35VDC, 24V AC (350 mA @9VDC)	9-35VDC, 24V AC (350 mA @9VDC)	9-35 VDC (600 ma @9VDC)

Ports and Pinouts

Ports and Pinouts are given in Figures 7-1 through 7-3.

Datapanel K

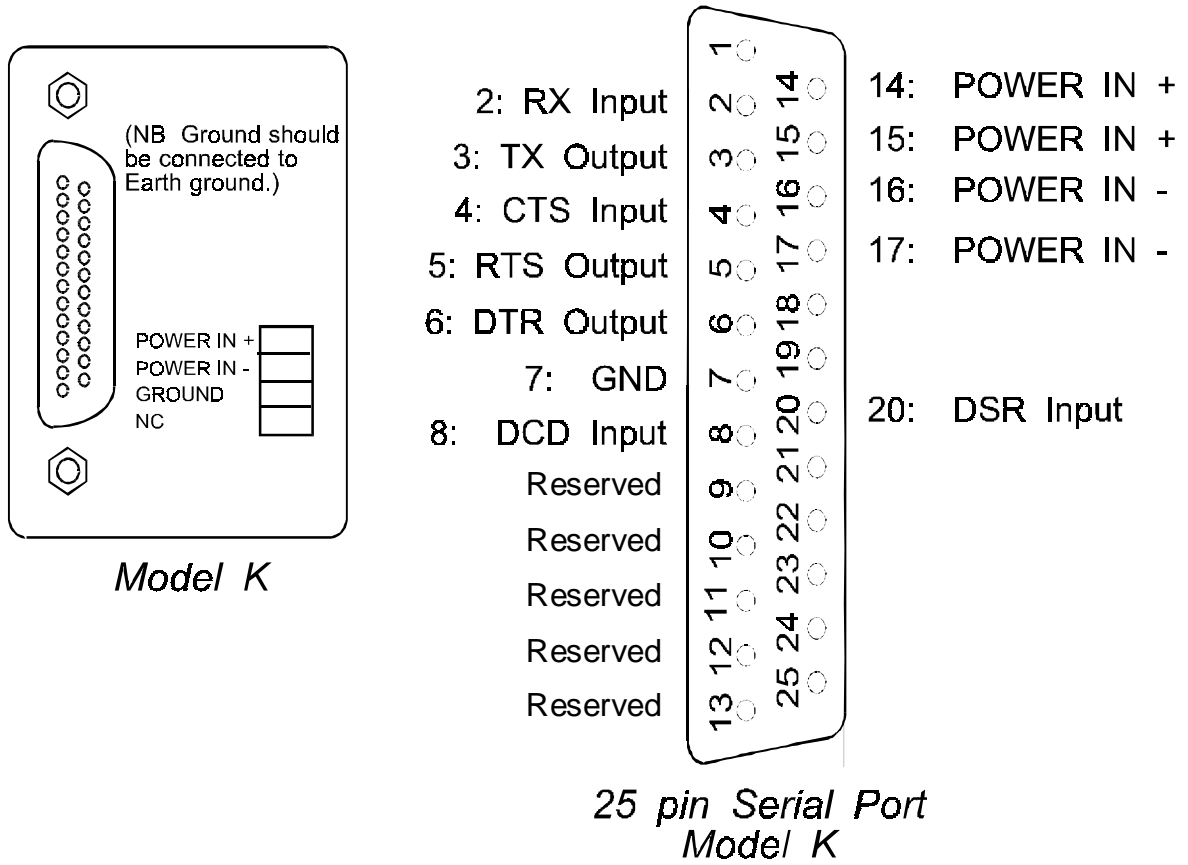
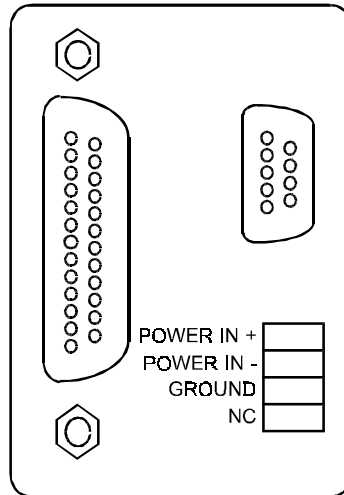
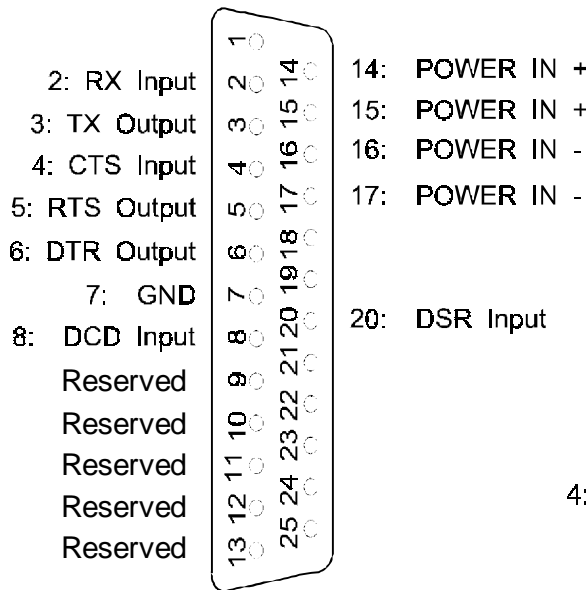

Figure 7-1. Model K Ports and Pinouts

Model J+



Model J+



*25 pin Serial Port
Model J+*

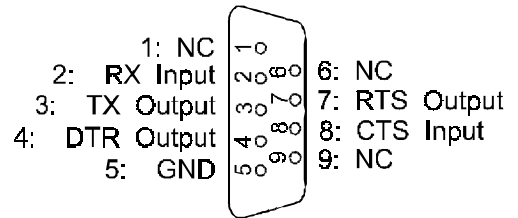

*9 pin Printer Port
Model J+*

Figure 7-2. Model J+ Ports and Pinouts

Datapanel H

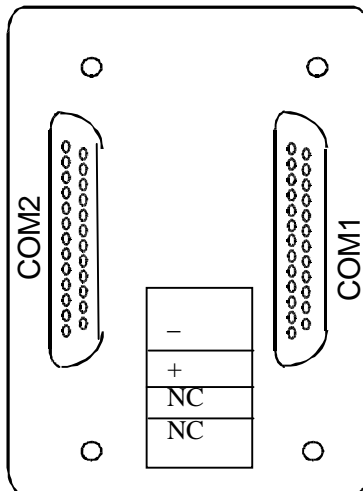

Model H

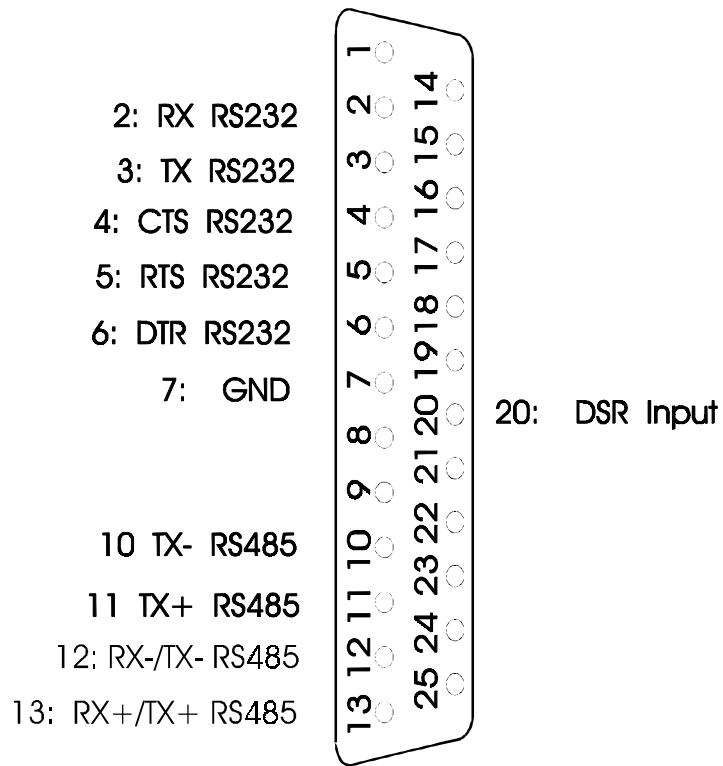

25 pin Serial Port
Model H

These pinouts apply to both COM1 and COM2 Ports

Figure 7-3. Model H Ports and Pinouts

Data Retention

Data retention characteristics are given in Table 7-6.

Table 7-6. Data Retention Characteristics

Model K	Model J+	Model H
No battery backup is provided. The System Software, protocols and database are all stored using the 256 kbytes of Flash memory.	Backup is provided for SRAM by the use of a lithium energy cell integrated within the Real-Time Clock circuit (not user replaceable). The System Software, protocols and database are all stored using the 256 kbytes of Flash memory.	On Model H, data for the 128 kbytes of SRAM and the Real-Time Clock, is retained by a charged capacitor for a minimum of 14 days when the system is powered down.
	Battery Life Typical: 10 years Worst: 5 years The battery life figures constitute total 'off-time'. For a Datapanel powered on half-time, the worst battery life figure would be at least 10 years.	

Real-Time Clock

Real-time clock characteristics are given in Table 7-7.

Table 7-7. Real-Time Clock Characteristics

Model K	Model J+	Model H
Clock set from the controller by configuring Clock Comms Blocks or manually from the keyboard	Real-Time clock standard	Real-Time clock standard

Environmental Conformity

Environmental conformity is given in Table 7-8.

Table 7-8. Environmental Conformity

Features	Model K	Model J+	Model H
NEMA, UL, CUL, CE	4X/4/12, UL, CUL, CE	4X/4/12, UL, CUL, CE	4/12, UL, CUL, CE; Haz. Loc. Class I Div. 2

All of the models above are designed to satisfy the requirements and conditions of the following specifications. All units above remained operational when tested for temperature, humidity and vibration to the specifications shown in Table 7-9.

Table 7-9. Test Specifications

	All Models
Temperature	Operating Temp. 0 to +40 °C, Storage Temp. -20 to +60°C
Humidity	5 to 85 % non – condensing

Networking with Datapanel

Model H (Mk2) Datapanel can be configured to network to a number of controllers on an RS-485 network, providing only one Datapanel is acting as communication master on the network. More than one Master on a network cannot be used. The controller must also be operating on the network. Other Datapanel can also be configured in this manner but will need an external RS-232 to RS-485 line converter.

Standard Comms Block Error Codes

101	Timeout
102	Checksum Received Error
103	Bad Character Received Format Error
104	Bad Message Framing Error
105	Bad Message Format Received
106	NAK Response Received
107	Comms Block Format Error
108	Invalid Command

System Error Codes

28	More than 64 comms blocks activated at the same frequency.
120	Tag Conversion error - unreasonable limits configured in an Analog Tag Record.
121	No Comms File.
122	No Comms Blocks.
123	Invalid Comms Block Time base.
124	Invalid Comms Block Type.

Controller Errors

If any errors are displayed which are not listed in the above tables, reference should be made to the configuration software Help system or to the controller documentation.

ACK	See Acknowledgment.
Acknowledgment	The action taken by the user to indicate the acceptance of the information presented by the system.
Alarm	An abnormal situation detected by the system, e.g., the violation of predefined limits by an input variable from the plant.
Alarm Limits	Limits set at the time the Datapanel was configured.
Alphanumeric	Alphabetic and numeric characters only.
Alphanumeric Display	A display of alphabetic and numeric characters only.
Analog	The characteristic of being able to take on any of a continuously variable range of values.
Analog Tag	An identifying name for an analog variable. See also Tag.
Analog Variable	A term used to describe a 16-bit integer, 32-bit integer, or floating-point number which may take many values.
ANSI	A character set optimized for the support of the French, German and Scandinavian characters.
Application Program	A user-defined program written to perform specific actions in addition to the system software functions.
Area Coloring	The coloring of a defined display area with a defined color.
ASCII	American Standard for Computer Information Interchange. Defines what numeric codes are used to represent numbers, punctuation and letters of the alphabet.
Attributes	The characteristics assigned to a graphic element such as: Blink, Position, Color.
Background Color	That part of the display that appears not to change as contrasted with a bar graph which changes with the value of the displayed parameter.
Backup	To copy and store data as a precaution against loss or damage. Also, the copy so created.
Bar Graph	A filled rectangular area whose height or horizontal length changes in proportion to a variable.
Baud, Baud Rate	User-configurable rates at which communication takes place between the system and the controller.
Bit	A binary value of 0 or 1. An area of memory dedicated to storing a binary value.
Bit Table	An area of memory dedicated to storing multiple bits.
Bitmap	A file that stores a graphic image in terms of bits. These bits are mapped to the screen to create the image.
Blinking	The effect created on a portion of a graphic which will allow it to change between two defined states at a specific rate.
Boot	
Browse	Scanning data in order to locate a required item.

Byte	A group of 8 consecutive bits.
Commands	Information sent from the Datapanel to the controller to control or modify the plant process.
Comms Block	See Communications Block.
Communications Block (Comms Block)	A group of user configured information describing a particular communications operation between the Datapanel and the controller.
Communications Protocol	The “language” to be used when the system communicates with a controller. It contains the rules used to establish contact, receive/transmit data, detect transmission errors, etc.
Configure	To set up the display system in accordance with the needs of a particular user. This includes user-specific displays, alarm criteria, etc.
Contiguous	A group of items stored in adjacent locations.
Controller	An industrial device that handles the Input/Output of plant voltages and signals, e.g., a Programmable Logic Controller.
Data	Information relating to the operation of the plant process.
Database	A structured set of data. In the Datapanel, databases are configured to customize the product to satisfy the needs of the user.
Datapanel	A self-contained, solid-state industrial display system incorporating its own display screen and keypad.
Datapanel Address	The Datapanel Register or Bit Table address to or from which data is to be transferred.
Digital	The characteristic of being able to take on only one of two possible states or conditions.
Digital Tag	An identifying name for a digital variable. See also Tag.
Download	Transmitting data from the configuration tool to the Datapanel.
Drive Out	The capability of the Datapanel which allows it to send information to the controller.
Drop-Down	A menu or list which appears in Windows upon selection of a menu item.
Dynamic	Any data element (tag value, graphic item, etc.) that can have changing values.
Firmware	Software (database, applications) stored in non-volatile memory, e.g., EPROM.
F-Key	See Function Key.
Flash memory	See Firmware.
Function Key	A key on a keyboard or keypad whose function is determined by software and may vary depending on the state of the software. Current definitions of the Datapanel function keys are displayed on the screen.
HMI (Human-Machine Interface)	Device enabling the two way transfer of data between a human and machine.
Host	Device on which the controlling software is resident.
I/O	See Input/Output.
Import	The ability to transfer configuration information into the Datapanel configuration tool from another application like a spread sheet.
Input/Output	A general expression for the input and output of binary data to or from a device.
Keyboard	A collection of physical keys used by the user to communicate with the computer system.
Keypad	An operator keyboard with a reduced number of keys, e.g., numeric and/or function keys.
LED	Light Emitting Diode. Typically used as a status indication light.
Macro	A collection of graphic elements used repeatedly thereafter in subsequent displays. This graphic application of the term differs from a macro instruction, a collection of instructions or program statements which can be activated collectively.
Master	The device controlling network communications.
Membrane	A continuous film intended to protect a device from the ingress of dust or liquid.

Mimic	A display which factually represents the plant. It provides the status of each displayed plant item. Mimics may be shown on monitors or wall displays.
Mini-Alarm Log	One of the Alarm area displays available when using the Datapanel. This display is found on all the Run Mode displays in the upper part of the screen.
NEMA	National Electrical Manufacturers Association. A group which sets American standards for enclosures which protect electronic equipment from the adverse affects of liquids, ingress of dust and physical shocks. Also, the standard created.
Network	An interconnected group of communicating devices.
Off-line	A condition where run time operations are suspended, so that system settings can be changed.
On-line	The system is communicating to external devices with dynamic data being updated.
Operator	The person who uses the system for its practical purpose such as to interface with the plant process. Not necessarily the one who configured the system. See also User.
Overview Group	A set of tags configured to be displayed together.
Page	One of 100 user configurable displays on the Datapanel.
Parallel	A data transfer mechanism using multiple transfer paths.
Parameter	A value set when the system is configured.
Parity	The means of checking the validity of a data character.
Password	A code used to show the authority of the user to gain access to various sensitive features of the system. For example, changes to the display design would normally be password-protected to guard against changes by unauthorized users.
PC	IBM Personal Computer or any computer generically similar.
Pixel	The smallest picture element of a display surface that can be independently assigned a color or intensity.
Plant Process	A series of actions or treatments designed to produce a desired end under the control or monitoring of a PLC or other intelligent controller.
PLC	Programmable Logic Controller.
Process	See Plant Process.
Process Variable	A variable parameter of the production process.
Programmable Logic Controller	An industrial device that handles the Input/Output of plant voltages and signals.
Protocol	The format, structure and procedure required to communicate with a controller.
RAM	Random Access Memory.
Ramp Drive-out	Pre-configured analog drive-out (Tag/Register) with a specific increment/decrement value.
Raw Data	Data read from the controller before being scaled into engineering values.
Real-Time Data	Current data.
Register	An internal memory location used for storing 16-bit representation of analog data in the Datapanel or controller.
Remote Address	The register or bit table address in the controller to or from which data is to be transferred.
Run Time	The operating state of the system. See also On-line.
Scaled Data	Raw data whose value has been modified to conform to prescribed engineering units.
Serial	A data transfer mechanism using a single transfer path.
Slave	The device which responds to a master over a network.
System Register	Same as any other register (see Register) but reserved for use by the system and cannot be modified by the user..
Tag	An analog or digital variable held in the Datapanel, usually representing an analog or digital variable in the controller. Includes additional information such as a name, size of the controller variable, scaling factors, alarm limits, etc.
Tag Record	An area of the database containing the information for a particular tag.

Tag Table	A group of Tag Values in the Datapanel.
Tag Value	The current value of the tag. This may be a scaled engineering value associated with the Tag Record.
Toggle	The action of inverting the value of a two-state item, such as a bit or a two-state digital tag.
Toolbar	A group of icons which provide easy access to other windows, menus or operations.
Touch Region	An area of the screen dimensionally defined to produce a program response when touched or pressed.
Trend	The graphical display of a variable in the form of a trace drawn with reference to X and Y coordinates.
Upload	Database transfer from Datapanel to WinCfg.
User	The person using WinCfg to configure a Datapanel. See also Operator.
WinCfg	A Windows-based tool for configuring Datapanel.

A

About menu, 6-2
Acknowledging Alarms, 1-2, 5-4
Additional Alarm Information, 5-4
Adjusting Display Attributes, 1-2
Alarm Conditions, 5-4
Alarms
 acknowledging, 1-2, 5-4
 additional information, 5-4
 displaying, 1-2, 5-4
 enabling and disabling, 6-9

B

Backlight, 7-1

C

Cables, 4-3
Capabilities, 2-1
Components of the System, 2-3
Configuration Software, 2-2
Configuring Host Communications, 6-9
Connecting Cables, 1-1
Connection Cables, 4-3

D

Data Retention, 7-7
Datapanel Models
 H, 3-3
 J+, 3-2
 K, 3-1
Datapanel
 mounting, 4-2
Display, 7-1
Display Attributes
 adjusting, 1-2
Display Control Menu, 6-2
Displaying Alarms, 1-2, 5-4
Drive Out Capabilities, 1-4

E

Electrical Specifications, 7-3
Enable/Disable Alarms, 6-9
Enhanced Drive Out, 5-7
Environmental Conformity, 7-8
Exit
 from Mode menu, 6-1

G

Glossary, B-4

H

Hardware requirements, 3-5
Hardware Specifications
 hardware, 7-1
Host Communications
 configuring, 6-9
Host Transfer, 6-8

K

Keypad, 7-2

M

Mode menu, 6-1
Modifying the Process, 1-3, 5-6
Mounting Datapanel, 4-2
Mounting the Datapanel, 1-1

N

Networking, 7-8

O

Off-line mode, 5-1
Off-Line Mode, 6-4
Operation, overview, 5-1
Overview Groups
 viewing, 1-2

P

Password Protection, 1-4, 5-6
Physical Characteristics, 4-1
Pinouts, 7-4
Ports, 7-4
Power Requirements, 7-3
Printing a Page, 1-2, 5-3

Q

Quick Start, 1-1

R

Real-Time Clock, 7-7
Requirements
 hardware, 3-5

Routine Processing, 5-3
Run mode, 5-1

S

Selecting a Tag and Entering a Value, 5-6
Serial Ports
 Configuring, 6-5
Setting the Time and Date Display, 1-2
Setting Time and Date Display, 6-6
Special Drive Out Capabilities, 5-7
Specifications, 7-1
 electrical, 7-3
 technical, 7-2
Startup, 1-1
System components, 2-3

T

Technical Specifications, 7-2
Time and Date Display
 setting, 1-2, 6-6
Typical Operation Scenarios, 5-3

V

Viewing Other Pages, 1-1, 5-3
Viewing Overview Groups, 1-2, 5-3