

**GFK-0448**  
**New In Stock!**  
**GE Fanuc Manuals**

[http://www.pdfsupply.com/automation/ge-fanuc-manuals/series-90-70-](http://www.pdfsupply.com/automation/ge-fanuc-manuals/series-90-70-9070/GFK-0448)

[9070/GFK-0448](http://www.pdfsupply.com/automation/ge-fanuc-manuals/series-90-70-9070/GFK-0448)  
**series-90-70-9070**

**1-919-535-3180**

User's Guide to Integration of 3rd Party VME Modules

[www.pdfsupply.com](http://www.pdfsupply.com)

**Email:** [sales@pdfsupply.com](mailto:sales@pdfsupply.com)

**GFK-0448**  
**New In Stock!**  
**~~GE Fanuc Manuals~~**

[http://www.pdfsupply.com/automation/ge-fanuc-manuals/series-90-70-](http://www.pdfsupply.com/automation/ge-fanuc-manuals/series-90-70-9070/GFK-0448)

[9070/GFK-0448](http://www.pdfsupply.com/automation/ge-fanuc-manuals/series-90-70-9070/GFK-0448)  
**series-90-70-9070**

**1-919-535-3180**

User's Guide to Integration of 3rd Party VME Modules

[www.pdfsupply.com](http://www.pdfsupply.com)

**Email:** [sales@pdfsupply.com](mailto:sales@pdfsupply.com)



# *GE Fanuc Automation*

---

*Programmable Control Products*

*Series 90™ -70  
Programmable  
Controller*

*User's Guide to Integration  
of 3rd Party VME Modules*

GFK0448E

December 1997

## *Warnings, Cautions, and Notes as Used in this Publication*

### **Warning**

**Warning notices are used in this publication to emphasize that hazardous voltages, currents, temperatures, or other conditions that could cause personal injury exist in this equipment or may be associated with its use.**

**In situations where inattention could cause either personal injury or damage to equipment, a Warning notice is used.**

### **Caution**

**Caution notices are used where equipment might be damaged if care is not taken.**

### **Note**

Notes merely call attention to information that is especially significant to understanding and operating the equipment.

This document is based on information available at the time of its publication. While efforts have been made to be accurate, the information contained herein does not purport to cover all details or variations in hardware or software, nor to provide for every possible contingency in connection with installation, operation, or maintenance. Features may be described herein which are not present in all hardware and software systems. GE Fanuc Automation assumes no obligation of notice to holders of this document with respect to changes subsequently made.

GE Fanuc Automation makes no representation or warranty, expressed, implied, or statutory with respect to, and assumes no responsibility for the accuracy, completeness, sufficiency, or usefulness of the information contained herein. No warranties of merchantability or fitness for purpose shall apply.

The following are trademarks of GE Fanuc Automation North America, Inc.

Alarm Master	Field Control	Modelmaster	Series 90
CIMPLICITY	GEnet	Motion Mate	Series One
CIMPLICITY Control	Genius	PowerMotion	Series Six
CIMPLICITY PowerTRAC	Genius PowerTRAC	ProLoop	Series Three
CIMPLICITY 90-ADS	Helpmate	PROMACRO	VuMaster
CIMSTAR	Logicmaster	Series Five	Workmaster

This manual provides the information necessary for evaluation of 3rd party VME modules for integration into a Series 90™-70 Programmable Logic Controller system.

## Revisions to This Manual

Revisions have been made to this manual to make additions, deletions, and corrections where necessary. Following is a list of the revisions to this manual as compared to the previous version, GFK-0448D.

- References have been made, where applicable, to programming and configuration of the Series 90-70 PLC using windows-based CIMPLICITY® Control programming software.
- Page 3-6, added information under *VME Interrupts* regarding the use of 3rd Party VME Interrupts in a Series 90-70 PLC system.
- Page 3-21 – 3-23, added information on *Interrupting the PLC CPU*.

## Content of this Manual

This manual contains the following information:

**Chapter 1. Introduction to the VMEbus Standard:** Provides a definition of the VMEbus standard including mechanical, electrical, and functional requirements.

**Chapter 2. Guidelines for Selection of 3rd Party VME Modules:** Describes the guidelines for successful integration of 3rd party VME modules in the Series 90-70 PLC.

**Chapter 3. Configuration of VME Modules:** Describes configuration requirements for addressing of VME modules in a Series 90-70 PLC system.

**Chapter 4. Installation of VME Modules:** Describes installation requirements for VME modules which must be adhered to when they are installed in a Series 90-70 PLC system.

**Chapter 5. Programming Requirements:** Describes the programming functions available with LogiMaster 90 software that allows the Series 90-70 PLC to communicate with 3rd Party VME modules.

**Appendix A. Commonly Used Acronyms and Abbreviations:** Provides a list of acronyms used throughout this guide, and their derivation.

**Appendix B. Why Do Restrictions Exist?:** Describes the reasons that some of the restrictions described in this guide exist for those who may require further explanation.

**Appendix C. Configuration Examples:** Provides examples of configuring 3rd Party VME Modules.

**Appendix D. Quick Compatibility Checklist:** Provides a checklist of key items to help you determine if a 3rd Party VME Module is compatible with the Series 90-70 PLC system.

**Appendix E. VMEbus International Trade Association:** Describes two documents which provide more information for users of VME-based products.

**Appendix F. VME Integrator Racks:** Data sheet providing detailed information about the GE Fanuc VME Integrator Racks.

**Appendix G. Application Bulletins:** Provides examples of applications using 3rd party VME modules into the Series 90-70 PLC system.

**Appendix H. Related VME Products:** Listing of VME products qualified by GE Fanuc for use with Series 90-70 PLC systems.

## Related Publications:

*GFK-0262: Series 90™ -70 Programmable Controller Installation Manual.* Describes system hardware components and provides installation and field wiring information for system planning and actual installation.

*GFK-0263: Logicmaster™ 90 Programming Software User's Manual.* Explains use of Logicmaster 90 software to configure a Series 90-70 Programmable Logic Controller and create application programs.

*GFK-0265: Series 90™ -70 Programmable Controller Reference Manual.* Describes the programming instructions used to create application programs for the Series 90-70 Programmable Logic Controller, system operation, fault explanations and corrections, and provides CPU performance data.

*GFK-0401: Workmaster® II PLC Programming Unit Guide to Operation.* Describes installation and operation of the Workmaster II computer, specifically when used as the programming device for a Series 90 Programmable Logic Controller.

*GFK-0552: VME Option Kit.* This is a data sheet describing the GE Fanuc VME Option Kit which is an accessory kit containing hardware for installing a J2 backplane.

*GFK-0637: Rack Fan Assembly.* This is a data sheet describing the GE Fanuc Rack Fan Assembly which is an option to provide forced air cooling for racks if required.

*GFK-0684: VME Integrator Racks - Front and Rear Mount.* This is a data sheet describing the GE Fanuc VME Integrator Racks for use with the Series 90-70 Programmable Logic Controller. The content of this data sheet is included in this manual as Appendix F.

*GFK-1179: Installation Requirements for Conformance to Standards.* Describes installation requirements for programmable control products used in industrial environments, specifically, in situations where more stringent requirements must be followed.

*GFK-1295: Using CIMPLICITY® Control.* Describes the features that are used to program the Series 90-70 PLCs using CIMPLICITY Control, which is a programming and configuration package that runs under either the Windows NT® (3.51 or 4.0) or Windows® 95 environments.

At GE Fanuc Automation, we strive to produce quality technical documentation. After you have used this manual, please take a few moments to complete and return the Reader's Comment Card located on the next page.

*Henry A. Konat*  
Senior Technical Writer

This page intentionally left blank.



<b>Chapter 1</b>	<b>Introduction to the VMEbus Standard</b>	<b>1-1</b>
	VMEbus Standard Definitions	1-1
	Mechanical Structure	1-1
	Power Supplies	1-3
	References	1-4
<b>Chapter 2</b>	<b>Guidelines for Selection of 3rd Party VME Modules</b>	<b>2-1</b>
	Environmental Considerations	2-1
	Use of Fans for Temperature Rating	2-2
	Power Supply	2-2
	Backplane Voltage Isolation	2-3
	Mechanical Restrictions	2-3
	VME Backplanes	2-4
	Series 90-70 PLC Support of Multi-Master Subsystems	2-5
	Categorization of Candidate Modules	2-6
	Bus Width	2-7
	Auxiliary VME Rack Capability	2-7
<b>Chapter 3</b>	<b>Configuration of VME Modules</b>	<b>3-1</b>
	VME System Overview	3-1
	Third Party Module Address Allocation	3-1
	GE Fanuc Series 90-70 Module Address Allocation	3-2
	Expansion Rack Considerations	3-4
	Bus Width Compatibility	3-5
	VMEbus Clock and System Functions	3-5
	VME Interrupts	3-6
	Slot Location Considerations for VME Modules	3-7
	VME Module Configuration	3-8
	Configuring 3rd Party Modules with Logicmaster 90-70	3-9
	Configuring a VME Module	3-10
	Selecting the Configuration Mode	3-11
	None Mode	3-11
	Interrupt Only Mode	3-12
	Bus Interface Mode	3-13
	Full Mail Mode	3-15
	Reduced Mail Mode	3-17
	I/O Scan Mode	3-19
	Interrupting the PLC CPU	3-21
<b>Chapter 4</b>	<b>Installation of VME Modules</b>	<b>4-1</b>
	Cooling for Optimum Operation	4-1
	Rack Standoffs for J2 Backplane Requirements	4-1
	Grounding Requirements	4-1
	Module Location in Racks	4-1

<b>Chapter 5</b>	<b>Programming Considerations</b> .....	<b>5-1</b>
	Programming Functions for Communicating with 3rd Party VME Modules . . . .	5-1
	Byte Significance Convention .....	5-1
	VME READ (VMERD) .....	5-2
	VME WRITE (VMEWRT) .....	5-5
	VMERead/MODIFY/WRITE(VMERMW) .....	5-8
	VME TEST AND SET (VMETST) .....	5-11
	VME_CFG_RD .....	5-14
	VME_CFG_WRT .....	5-16
	SWAP .....	5-18
<b>Appendix A</b>	<b>Commonly Used Acronyms and Abbreviations</b> .....	<b>A-1</b>
<b>Appendix B</b>	<b>Why Do Restrictions Exist?</b> .....	<b>B-1</b>
	Interrupts and a 3rd Party Interrupt Handler .....	B-1
	AM Codes and Expansion Racks .....	B-1
	Restrictions for AM Code 29H .....	B-1
	Restrictions for AM Code 39H .....	B-2
	Restrictions for AM Codes 0DH and 09H .....	B-2
	Restrictions for AM Code 2DH .....	B-2
<b>Appendix C</b>	<b>Configuration Examples</b> .....	<b>C-1</b>
	Example 1 - Single Slot Module Located in the Main Rack .....	C-1
	Example 2 - Single Slot Module Located in an Expansion Rack .....	C-3
<b>Appendix D</b>	<b>Quick Compatibility Checklist</b> .....	<b>D-1</b>
<b>Appendix E</b>	<b>VMEbus International Trade Association</b> .....	<b>E-1</b>
<b>Appendix F</b>	<b>VME Integrator Racks</b> .....	<b>F-1</b>
	Default Jumper Configurations .....	F-6
<b>Appendix G</b>	<b>Application Bulletins</b> .....	<b>G-1</b>
<b>Appendix H</b>	<b>Related VME Products</b> .....	<b>H-1</b>

Figure 3-1. VME Interrupts between 3rd Party Modules .....	3-6
Figure 3-2. VME Interrupts from 3rd Party Modules .....	3-21
Figure F-1. VME Integrator Rack .....	F-2
Figure F-2. VME Integrator Rack Dimensions for Rear (Panel) Mount Installation .....	F-3
Figure F-3. VME Integrator Rack Dimensions for Front (Rack) Mount Installation .....	F-3
Figure F-4. Example of Jumper Locations on Backplane .....	F-5
Figure F-5. Rack Number Jumpers .....	F-9
Figure F-6. Fan Assembly Mounted on Rack .....	F-11

Table 2-1. Important Environmental Specifications .....	2-1
Table 2-2. Series 90-70 PLC Power Supply Ratings .....	2-3
Table 2-3. VME Option Kit (IC697ACC715) .....	2-5
Table 3-1. AM Code Types .....	3-1
Table 3-2. GE Fanuc Series 90-70 Module Address Allocation for Short Access AM Codes - 29H and 2DH .....	3-2
Table 3-3. GE Fanuc Series 90-70 Module Address Allocation for Standard Access AM Code - 39H .....	3-3
Table 3-4. Programmed AM Codes for Short Non-Privileged Access code 29H .....	3-4
Table 3-5. Programmed AM Codes for Short Supervisory Access AM Code 2DH .....	3-5
Table 3-6. Modes of Configuration for 3rd Party VME Modules .....	3-8
Table 3-7. Third Party VME Features vs. Configuration Modes .....	3-9
Table 3-8. Parameters for INTERRUPT ONLY Configuration Mode .....	3-12
Table 3-9. Parameters for BUS INTERFACE Configuration Mode .....	3-13
Table 3-9. Parameters for BUS INTERFACE Configuration Mode – Continued .....	3-14
Table 3-10. Parameters for FULL MAIL Configuration Mode .....	3-16
Table 3-11. Parameters for REDUCED MAIL Configuration Mode .....	3-18
Table 3-12. Parameters for I/O Scan Configuration Mode .....	3-20
Table C-1. Example 1 - Series 90-70 Configuration 1 .....	C-1
Table C-2. Example 1 - Series 90-70 Configuration 2 .....	C-1
Table C-3. Example 1 - Configuration 1 Available Address Range .....	C-2
Table C-4. Example 1 - Configuration 2 Available Address Range .....	C-2
Table C-5. Example 2 - Series 90-70 Expansion Rack Configuration .....	C-3
Table C-6. Example 2 - Available Address Range .....	C-3
Table F-1. VME Integrator Rack Jumper Location and Function .....	F-7
Table F-2. VME Integrator Rack Specifications .....	F-12
Table F-3. VME Integrator Rack Ordering Information .....	F-12

# Chapter 1

## *Introduction to the VMEbus Standard*

---

---

VMEbus is an architecture for connecting and interfacing microcomputer based modules. Originally defined by Motorola, Mostek and Signetics corporations, it is now a recognized international standard:

IEEE/ANSI STD 1014-1987  
IEC 821 and 297

The abbreviation VME stands for VERSA Module Eurocard. When the first VMEbus specification was under development, the Eurocard format for printed circuit boards and racks was well established in Europe, with many sources for this hardware.

### **VMEbus Standard Definitions**

The VMEbus standard defines the mechanical and functional characteristics of the interconnection. It does not ensure the operating compatibility of VMEbus modules. There are many options to the VMEbus that may cause two VMEbus modules, both of which adhere to the standard, to be incompatible with each other.

VMEbus features and options include:

- 16, 24, and 32 bit address bus options
- 8, 16, and 32 bit data bus options
- up to seven interrupt levels
- a master-slave architecture
- multiple masters
- two heights of modules and racks
- one or two backplanes
- high data transfer rate between modules
- asynchronous data transfers - no clocks required to transfer data
- non-multiplexed bus - separate address and data pins.

### **Mechanical Structure**

The VMEbus mechanical structure consists of backplanes, boards or modules, slots and racks.

- two board and rack heights, designated as 3U and 6U
- up to 21 modules per rack
- slots on 0.8 inch centers
- maximum bus signal length of 19.37 inches (500 mm)

## Backplanes

All VME racks contain the J1 (upper) backplane. This backplane allows 16 and 24 bit addresses, and 8 and 16 bit data transfers. 3U (5.25 inch) high racks have only the J1 backplane and support only 3U size boards. 3U modules connect only to the J1 backplane.

6U (10.5 inch) high racks have the J1 backplane and, optionally, the J2 (lower) backplane. The J2 backplane provides additional standard lines for 32 bit addressing, 32 bit data and additional DC power. The J2 backplane also has unused lines which many manufacturers use for other busses or I/O.

6U modules are more popular than 3U modules. Like 3U high modules, they connect to the J1 backplane. In addition, 6U modules may connect to the J2 backplane. 6U modules which use 32 bit addressing or data, must be in a rack with a J2 backplane.

The connector on a module which plugs into the J1 backplane is referred to as P1; the connector on a module which plugs into the J2 backplane is referred to as P2. Racks may have up to 21 slots. The VMEbus standard refers to the mechanical structure containing the backplane(s) and slots as a subrack.

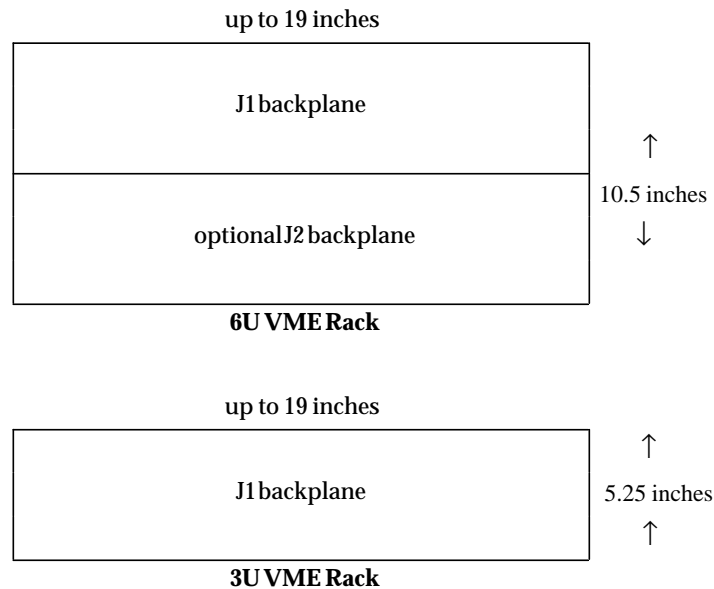

### ■ Functional Structure

The VMEbus contains numerous functional modules, only some of these are defined here. The VMEbus consists of four subbuses:

- Data Transfer Bus (DTB)
- Data Transfer Arbitration Bus
- Priority Interrupt Bus
- Utility Bus.

## Data Transfer Bus (DTB)

The Data Transfer Bus contains 32 data bits and 32 address bits. Associated with an address is a six-bit Address Modifier (AM) code. The AM code indicates the type and size of the address. An address may be one of three types:

- Short: 16 address bits
- Standard: 24 address bits
- Extended: 32 address bits.

A bus timer function is active during each Data Transfer Cycle. The bus timer monitors the time consumed by the transfer and terminates the cycle if the time becomes unreasonably long. The bus timer is typically located in the module in slot 1 (also called the slot 1 controller).

## Data Transfer Arbitration Bus

A functional module, the arbiter, determines which requesting module will be granted use of the DTB. This function is always located on the module in slot 1 (also called the *slot 1 controller*).

Master modules initiate data transfer cycles. Slave modules receive data transfer requests and respond to them. A module may act as a master sometimes and as a slave at other times. Or it may be strictly a master or strictly a slave. Slave boards look like memory to the VMEbus.

## Interrupt Priority Bus

The VMEbus standard defines up to seven interrupt priority levels. An interrupter asserts one of the interrupts lines - designated IRQ1 through IRQ7. An interrupt handler acknowledges the interrupt and takes some action based upon the interrupt. Interrupt handlers are usually found on CPU-type modules.

Interrupts are acknowledged via a daisy chained IACK line. Because this line is daisy chained, interrupts cannot function if there is an empty slot (J1 connector) between the interrupt requestor and the interrupt handler.

## Utility Bus

The Utility Bus contains power, ground, a system clock and signals for coordinating system reset, system failure and loss of power. Refer to VMEbus specifications for details see Appendix E).

## Power Supplies

There is no VME standard for interconnection of power supplies and backplanes. Power supplies for VMEbus systems come in both Eurocard and open frame form factors. Eurocard type supplies reside in the VME rack but do not have a direct backplane plug-in connection. They are instead cabled from the back of the supply to terminals on the rear of the backplane(s). Open frame supplies mount external to the rack, and are also cabled to the rear of the VME backplane(s).

VME-based systems can have high power requirements. Power supplies of 400 watts output per rack are not unusual. Most VME-based systems require cooling fans, often

for operation even at room (ambient) temperatures. A Rack Fan Assembly (catalog number IC697ACC721 for 120 VAC power source or IC697ACC724 for 240 VAC power source) is available from GE Fanuc for those applications which require additional cooling. These fans are available in fan trays which rack mount directly below the VME rack. Systems that include only GE Fanuc products do not need additional cooling over the specified temperature range, 0° to 60°C (32 ° to 140°F).

The VMEbus signals SYSRESET and ACFAIL are used for generating system reset at power up and for providing advance warning of power failure. These signals are provided either directly from the power supply, or from a separate power monitor module in the rack.

The optional SYSFAIL signal is user-defined in its causes and system response.

## References

Useful reference information on the VMEbus is available from several publications. All of these publications are available from the VMEbus International Trade Association (VITA). Refer to Appendix E for more information and the address of VITA.

### *The VMEbus Handbook*

An informative collection of useful information on VME, which is much easier reading than the VMEbus Specification.

### *VMEbus Specification*

This is the IEEE 1014-87 standard.

### *VME Compatible Products Directory*

Lists over 3000 boards (racks, software, etc.) from over 300 manufacturers, with capsule descriptions of each. Includes a fairly comprehensive cross reference. This directory is updated twice per year.



# Chapter 2

## Guidelines for Selection of 3rd Party VME Modules

This chapter describes the guidelines for successful integration of 3rd party VME modules in the Series 90™-70 PLC. VME is an international standard which defines physical board size, electrical and busing structure using standard DIN connectors for the interconnect of 8, 16, and 32 bit microprocessors.

Successful integration of 3rd party VME modules in the Series 90™-70 PLC is guided by the following criteria:

- The module selected must comply with the *VMEbus Specification REV C.1 (October 1985)*. No earlier version of this specification may be used.
- The module selected must be compatible with the particular characteristics of the Industrialized VMEbus (VME-I) as implemented on the GE Fanuc Series 90-70 PLC.
- The module selected must not interfere with the normal operation of the Series 90-70 PLC system.
- Bus slaves rather than bus masters are preferred, as they are easier to integrate into the Series 90-70 PLC system.
- No more than three 3rd Party VME modules may be placed in a standard Series 90-70 PLC rack.
- 3rd Party VME modules cannot be used in a remote Series 90-70 rack controlled by a Series 90-70 Remote I/O Scanner module.

Also refer to the checklist in Appendix D.

### Environmental Considerations

In selecting a VME module for operation with the Series 90-70 PLC system, it is necessary to pay close attention to the environmental ratings of the module since these individual module ratings may limit overall system rating. The specifications which need to be determined are listed below along with the corresponding Series 90-70 PLC ratings for each specification. For more detailed information on product agency approvals, standards, and general specifications for Series 90-70 products refer to data sheet GFK-0867.

Table 2-1. Important Environmental Specifications

Specification	Series 90-70 PLC Rating
Operating Temperature	0° to 60° C (32° to 140° F), (inlet air at bottom of rack)
Storage Temperature	-40° to 85° C (-40° to 185° F)
Humidity	5% to 95% (non-condensing)
Vibration	1G @40-150Hz, 0.012in p-p @10-40Hz
Shock	15 g's for 11 msec

In selecting VME modules, consideration must be given to maintaining acceptable component temperature when the VME module has other modules on either side of it, each dissipating up to 17 watts. The VME module itself should not exceed 17 Watts if this specification is to be met.

## Use of Fans for Temperature Rating

A characteristic of the Series 90-70 PLC Industrialized VMEbus (VME-I), is that low power technology is employed in order to achieve the full temperature rating for Series 90-70 PLC modules without the use of fans. When selecting VME modules from other vendors for use in the Series 90-70 PLC, it must be determined whether fans are required to achieve the specified VME module temperature rating in a Series 90-70 PLC installation. If fans are needed, an optional Rack Fan Assembly is available from GE Fanuc.

## Power Supply

The VMEbus includes both a +5 volt bus and " 12 volt busses; however, not all Series 90-70 PLC power supplies have a " 12 volt output, and the output current rating of the +5 volt bus depends on the model of Series 90-70 PLC power supply chosen. Also, a Two Rack Power Cable is available which allows two racks to be operated from a single Series 90-70 PLC power supply. The following limitations apply to power supplies:

- Only modules which use +5 volts may be used in the rack (second rack) without the power supply (the " 12 volt busses are not carried in the Two Rack Power Cable).
- Current rating of the +5 volt bus in the second rack (without power supply) is limited to 5.2 amperes or less.
- None of the Series 90-70 PLC power supplies fully support the +5 volt standby bus. The 55 Watt supply has no connection between the +5 volt standby backplane line and the +5 volt power bus. If +5 volt standby power is required by a VME module, a method must be supplied by the user to route power to that backplane line if the 55 watt power supply is being used. The other supplies connect the +5 volt standby power to the +5 volt bus during operation, but are electrically isolated from it following power down.
- Series 90-70 AC power supplies will ride through a 1 cycle loss of AC input power without system interruption. If the loss exceeds 1 cycle, the ACFAIL signal will be asserted and a shutdown procedure will begin after a 5 millisecond holdup time of backplane power busses.

### Note

The maximum current required for any single VME module is restricted to 4.5 amperes or less (worst case) on the +5 volt bus (3 amps recommended maximum) due to the J1 backplane connector capacity. If additional capacity is required some modules allow a J2 connector to carry additional current to the module.

Power supply ratings for the Series 90-70 PLC power supplies are listed below.

**Table 2-2. Series 90-70 PLC Power Supply Ratings**

Catalog Number	Description	Current Rating (Amps)		
		+5 VDC	+12 VDC	-12 VDC
IC697PWR710	Power Supply, 120/240 VAC or 125 VDC, 55W	11	n/a	n/a
IC697PWR711	Power Supply, 120/240 VAC or 125 VDC, 100W	20	2.0	1.0
IC697PWR724	Power Supply, 24 VDC, 90W	18	1.5	1.0
IC697PWR748	Power Supply, 48 VDC, 90W	18	1.5	1.0

n/a = not available

**Note**

For multiple output power supplies, the current ratings given are individual bus maximums. The total power of all three must not exceed the wattage rating of the power supply.

**Backplane Voltage Isolation**

Series 90-70 PLC Discrete and Analog I/O modules (called Model 70 I/O) provide 1500V opto-isolation between user (field) connections and the Series 90-70 PLC backplane to prevent system misoperation or damage in the event of transients which occur on user wiring to the modules. In selecting VME modules, preference should be given to those modules which provide such isolation.

**Note**

If no isolation from PLC backplane to field connections is provided, system noise immunity may be compromised.

**Mechanical Restrictions**

The standard Series 90-70 PLC racks (IC697CHS750/790/791) accommodate modules on 1.6" centers (double VME width). VME modules which are single width (0.8") require a cover plate for the unused half of the rack opening to keep out foreign objects. A cover plate made of non-conductive material is available from GE Fanuc. *DO NOT* use metal cover plates since they can short to the back of GE Fanuc I/O modules (which have electrically hot field wiring) as they are removed from or inserted into the rack.

VME Integrator racks (IC697CHS782/783) are available that have 17 slots and will accept 3rd Party VME modules in each slot which require 0.8" spacing. These racks also accept Series 90-70 modules which require two of these VME slots (1.6" spacing).

Certain VME modules have more than one PC board, each with a connection to the backplane. Modules having this type of construction in which the PC boards are on single-slot (0.8") spacing *CANNOT* be used with standard racks since the standard Series 90-70 PLC backplane has slots (card guides and connectors) on 1.6" centers only. These VME modules can be used when installed in a VME Integrator rack which has slots on 0.8" centers.

The Series 90-70 PLC rack accepts double-high modules designated as 6U in the *VMEbus Compatible Products Directory* in the *Compatibility* column. No direct provision is made for single high VME modules indicated by a 3U designation. However, such modules may be used if a commercially available 6U faceplate adapter is attached to the 3U module to allow securing it to the rack rails. Such faceplate adapters are often supplied by the vendor of the 3U high board.

## VME Backplanes

The VME standard specifies two backplanes, designated J1 and J2. The Series 90-70 PLC system only contains the J1 backplane; there is no J2 backplane. If the J2 backplane is required, you must purchase a VME Option Kit (IC697ACC715) which contains the hardware and rail necessary to install a J2 backplane *but does not contain a J2 backplane*. This kit also contains mounting standoffs to allow rear-mounted racks to have a J2 backplane added. The J2 backplane, which can be different widths, must be obtained from a VME vendor.

### Note

None of the standard Series 90-70 PLC Power Supplies make direct connection to the J2 backplane. However, the VME Integrator rack does provide for this connection through a cable.

If power is required on the J2 backplane, it must be connected by the user. One method is to use a modified Two Rack Power cable, IC697CBL700, normally used for second rack operation from one supply. The use of this cable allows +5 VDC power from a connector at the left end of the J1 backplane to be routed to the J2 backplane to make the required connection. If this technique is used, the ability to power a second rack from the power supply in this rack is lost. To use the cable in this manner, the connector at one end must be removed and adapted for connection to the selected J2 backplane. The +5 volts and common are each carried on several wires in this cable. It is necessary to maintain the parallel connection of these conductors to achieve the required current carrying capacity of the cable. Two wires in this cable, which carry the ACFAIL and SYSRESET signals, must be disconnected at the power supply end of the cable.

## J2 Backplane

Sometimes a J2 backplane is required in a Series 90-70 PLC system that includes 3rd party (non-GE Fanuc) modules. Since GE Fanuc modules do not use the J2 backplane, the selection of a J2 backplane depends on the requirements of the third party modules in the system.

J2 backplanes are available in many different lengths (typically 2 to 21 slots) and with different types of power pick-up connectors. Also, some backplanes pre-buss and terminate row **b** while allowing rows **a** and **c** to be user defined. Some backplanes allow totally user defined pinouts. Some backplanes include on-board termination, and some require off-board termination.

The J2 backplane can be used in many different ways by 3rd party modules. Sometimes it is required only to provide parallel power paths to the module (in addition to J1), and sometimes J2 is needed only to make user interface connections to the module. If 3rd party modules are communicating with each other using 32 bit addressing, then the J2 backplane is used for address bits 24 through 31 (and/or data bits 17 through 31). To determine the correct backplane option to use, the requirements of all the third party modules in the system must be taken into consideration. The manufacturers of the 3rd party modules may need to be consulted to determine the best backplane choice for your application.

J2 backplanes are available from many different vendors. A fairly complete list is available in the VITA Compatible Products Directory. Two vendors that are listed in this directory who have large selections of backplane products are listed on the following page.

BICC VERO ELECTRONICS  
1000 Sherman Avenue  
Hamden, CT 06514  
1-800-BICC-VME

DAWN VME PRODUCTS  
47073 Warm Springs Blvd.  
Fremont, CA 94539  
1-800-258-DAWN

### VME Option Kit Contents

The VME Option Kit contains sufficient parts to enable you to add a J2 backplane to a GE Fanuc rack. The kit consists of the following components.

Table 2-3. VME Option Kit (IC697ACC715)

Description	Quantity
Connector jumper	6
M2.5 threaded strip	2
Aluminum spacer	4
VME slot filler	4
Phillips screws, M2.5 x 8	20
Spring lock washers	20
Power cable	1
Manual, GFK-0448, Series 90-70 User's Guide to Integration of 3rd Party VME Modules	1

The J2 backplane is purchased from a 3rd party source. The width of the backplane is determined based on the number of slots required.

### Series 90-70 PLC Support of Multi-Master Subsystems

The Series 90-70 PLC system is based on the VME standard.

A Series 90-70 PLC system always requires a Series 90-70 PLC CPU to be located in slot 1 of rack 0 which performs the slot 1 controller functions. It is also a bus master, but only one Series 90-70 PLC CPU can be located in the same Series 90-70 PLC system.

A VME master is a device which is granted temporary control of the bus by the slot 1 controller. A bus master can initiate read and write functions to any supported VME address. The VME bus can support multiple master subsystems. Devices which are capable of master operation but which operate on;y as slaves are not considered masters in the context of this discussion.

Third party VME masters located in the same rack as the Series 90-70 PLC CPU may communicate directly with other 3rd party VME devices in a Series 90-70 PLC system which are in the main rack or in expansion racks without the PLC CPU application participating in the transaction.

Programmable Coprocessor Modules (PCMs) having revision J, or later, can also act as VME master in any Series 90-70 PLC rack.

**Restrictions:**

- Third party VME masters are not supported in racks with Bus Receiver Modules (BRMs), or Remote I/O Scanner modules, nor by Series 90-70 CPUs not supporting this feature (CPUs with catalog numbers earlier than IC697CPU731P, IC697CPU732D, IC697CPU771M, IC697CPU772D, IC697CPU781F, or IC697CPU782F). All versions of CPUs with catalog numbers IC697CPU780, IC697CPU788, IC697CPU789, IC697CPM914, and IC697CPM924 (CPM924 will be available in early 1994) all provide multi-master support.
- The Series 90-70 PLC does not have a dual ported memory with VME addresses and does not have facilities to allow association of VME interrupts with user applications and therefore VME masters cannot initiate communications with the Series 90-70 PLC CPU except by using a common VME memory which might be a dual ported memory on the VME master.
- Other Series 90-70 PLC modules use ASIC chips and an unpublished proprietary messaging protocol to communicate with the Series 90-70 PLC CPU and direct communications with these modules from third party VME masters is not supported.

**Categorization of Candidate Modules**

VME modules are categorized in several ways. The first is by whether they are bus master modules or bus slave modules. Bus Master modules control the transfer of data between themselves and other modules on the VMEbus. Bus slaves do not control the bus; typically, they have an interface to the VMEbus which can be addressed (data read or written) by a VMEbus master, for example, the Series 90-70 PLC CPU.

The second way of categorizing VME modules is by the number of address and data bits they support. The *VMEbus Compatible Products Directory* refers to these as the module's address and data width specification. Both categorization methods are discussed below.

**Bus Master Modules**

To control data transfers, bus master modules *control* the bus itself and can potentially interfere with the Series 90-70 CPU which also is attempting to use that bus for communication among modules on the bus. The use of foreign bus master modules is restricted so that improper interaction with the Series 90-70 CPU does not occur. These restrictions include:

- Must use a Series 90-70 CPU that allows foreign VME master support (see the above discussion on *Series 90-70 PLC Support of Multi-Master Subsystems*).
- The Series 90-70 CPU is always the *slot 1* controller. If a 3rd party bus master contains bus arbitration or clock circuitry, that circuitry must be disabled.
- Bus requests must be made only on Bus Request lines BR2 or BR3. Bus Request lines BR1 and BR0 are reserved by the Series 90-70 PLC. The priority of these lines in the Series 90-70 system is BR1 highest, followed by BR0, BR3, and BR2.
- Upon receipt of a Bus Clear (BCLEAR) signal, bus masters must release the bus within 40 microseconds (maximum).
- Bus masters *must* not use block move cycles.
- All bus access in the Series 90-70 CPU is limited to 8 or 16 data bits and 16 or 24 address bits. 3rd party modules may communicate with each other using up to 32 data bits and 32 address bits if a J2 backplane is used.

- Bus masters must never service interrupts IRQ5, IRQ6, or IRQ7. Refer to *Interrupts* on page 3-5 for more information on interrupts.
- Bus masters cannot be used in expansion racks.
- There is no dual-ported RAM memory on the Series 90-70 PLC CPU directly accessible from the VMEbus. Even with the Series 90-70 CPUs listed above, a foreign VME bus master cannot initiate a read or write to the Series 90-70 CPU.

## Bus Slave Modules

Slave VME modules often have a shared RAM interface through which the VME module data is exchanged with the VMEbus master. Flow of data between the slave module and the VMEbus is controlled by the bus master module. Certain slave modules may have interrupt capability which, if used, must be done with care and in such a way as not to interfere with the Series 90-70 PLC system (for details, refer to **Interrupts** on page 3-5). *Currently, VME modules may interrupt only each other, not Series 90-70 modules, Series 90-70 PLC I/O modules, or the Series 90-70 CPU.*

## Bus Width

VME modules transfer data in three widths: 8 bits, 16 bits, and 32 bits. Some modules support all three, some only two (typically 8 and 16 bits) and some only one. The Series 90-70 PLC supports data widths of 8 bits and 16 bits. *It does not support a data width of 32 bits.* Typically, only modules which transfer data in 8-bit or 16-bit widths are compatible with the Series 90-70 PLC.

VME module support up to three address widths: 16 bits, 24 bits and 32 bits. These are referred to, respectively, as Short (16 bits), Standard (24 bits) and Extended (32 bits). The Series 90-70 PLC supports address widths of 16 bits and 24 bits. *It does not support 32 bit address widths.* If your module requires a 32-bit address you may still be able to use it by either wiring the 25th through 32nd address bits or by installing a J2 backplane and driving the 25th through 32nd address lines external to the VME module. See **Appendix D, Why Do Restrictions Exist?** for additional information.

## Auxiliary VME Rack Capability

Sometimes functionality is required that can only be met with the use of a commercially available VMEbus extender or Reflective Memory module to interconnect a second, auxiliary VME rack to the Series 90-70 PLC. Such extenders have boards in both the Series 90-70 PLC rack and the auxiliary VME rack and are connected through a cable. When using these bus extenders, they must be set up to allow the two racks to communicate via a shared RAM interface on one of the boards (NOT as an electrical extension of the VMEbus). This shared RAM technique provides a means to structure the complete user-specific system in the auxiliary rack including bus masters, interrupts, etc. as desired with no direct effect on the Series 90-70 PLC operation. The Series 90-70 PLC Bus Transmitter Module and Bus Receiver Module do **NOT** provide this full capability as the Bus Receiver Module does not arbitrate or respect arbitration for bus mastership.

# Chapter 3

## Configuration of VME Modules

### VME System Overview

The address on a VMEbus consists of two parts: an address modifier (AM) code and address bits A0 through A31. All boards in a VME system are configured to respond to one or more AM codes and an address range. The AM code can be considered an extension of the address bus. The AM code consists of 6 bits and is used to select the type of VME access (that is, the number of address bits used). There are 64 possible AM codes which are divided into three categories:

- Defined
- Reserved
- User-Defined

The access types and address length for defined AM codes are given in Table 3-1.

Table 3-1. AM Code Types

Access Type	Address Length	Bits Used
Short	16 bits	A0 - A15
Standard	24 bits	A0 - A23
Extended	32 bits	A0 - A31

The GE Fanuc Series 90-70 modules use three of the defined codes:

- 29H *Short* non-privileged
- 2DH *Short* supervisory
- 39H *Standard* non-privileged

There are no reserved AM codes used in the Series 90-70 PLC. The Series 90-70 PLC system also uses all 16 of the user-defined AM codes, 10H through 1FH. These AM codes are discussed later in this chapter.

### Third Party Module Address Allocation

Address allocation for 3rd party modules is driven by three items: AM code, GE Fanuc Series 90-70 module location, and 3rd party module location.

Address assignments for 3rd party modules are typically setup with jumpers. The addresses assigned to 3rd party modules must not overlap installed GE Fanuc Series 90-70 modules or other 3rd party modules.



## GE Fanuc Series 90-70 Module Address Allocation

Addresses for the GE Fanuc Series 90-70 modules are allocated on a rack and slot basis. Address allocation is also based on the VME access type. The address allocation for GE Fanuc modules in the Series 90-70 system are given in the following tables. This information is necessary to determine what unused address space can be allocated to 3rd party modules.

The short access address allocation given in Table 3-2 is the same for each rack. Rack selection is discussed in *Expansion Rack Considerations* on page 3-3.

The standard access address allocation given in Table 3-3 is allocated on a rack/slot basis. Standard access address space allocated to a rack cannot be used for a 3rd party module located in another rack. For example, standard access address space allocated to a slot in rack 1 cannot be used by 3rd party modules in another rack.

GE Fanuc Series 90-70 modules plugged into slots indicated in these tables will respond to the listed address. Therefore, care must be taken to assure that a 3rd party module will not respond to an address allocated to a slot which contains a GE Fanuc Series 90-70 module. For example, a PCM residing in rack 0 slot 3 will respond to the following address:

- address range 1800H through 1FFFH for AM code 29H and 2DH;
- address range 020000H through 03FFFFH for AM code 39H

**Table 3-2. GE Fanuc Series 90-70 Module Address Allocation for Short Access AM Codes - 29H and 2DH**

Slot	Address Range †
PS	none
1	none
2	1000H-17FFH
3	1800H-1FFFH
4	2000H-27FFH
5	2800H-2FFFH
6	3000H-37FFH
7	3800H-3FFFH
8	4000H-47FFH
9	4800H-4FFFH
User Defined	5000H-FFFFH

† Addresses in Hexadecimal

### Note

If a 3rd party VME module responds to both AM codes 29H and 2DH, then it should be mapped in the *user defined* address range. Refer to Appendix B *Why Do Restrictions Exist?* for more details.

**Table 3-3. GE Fanuc Series 90-70 Module Address Allocation for Standard Access AM Code - 39H**

Rack Number	Slot Number/Address Allocation							
	2	3	4	5	6	7	8	9
0	00000 to 01FFFF	020000 to 03FFFF	040000 to 05FFFF	060000 to 07FFFF	080000 to 09FFFF	0A0000 to 0BFFFF	0C0000 to 0DFFFF	0E0000 to 0FFFFF
0	100000through 7FFFFFF User Defined for Rack 0 Only							
1	E0000 to E1FFFF	E20000 to E3FFFF	E40000 to E5FFFF	E60000 to E7FFFF	E80000 to E9FFFF	EA0000 to EBFFFF	EC0000 to EDFFFF	EE0000 to EFFFFF
2	D00000 to D1FFFF	D20000 to D3FFFF	D40000 to D5FFFF	D60000 to D7FFFF	D80000 to D9FFFF	DA0000 to DBFFFF	DC0000 to DDFFFF	DE0000 to DFFFFF
3	C00000 to C1FFFF	C20000 to C3FFFF	C40000 to C5FFFF	C60000 to C7FFFF	C80000 to C9FFFF	CA0000 to CBFFFF	CC0000 to CDFFFF	CE0000 to CFFFFF
4	B00000 to B1FFFF	B20000 to B3FFFF	B40000 to B5FFFF	B60000 to B7FFFF	B80000 to B9FFFF	BA0000 to BBFFFF	BC0000 to BDFFFF	BE0000 to BFFFFF
5	A00000 to A1FFFF	A20000 to A3FFFF	A40000 to A5FFFF	A60000 to A7FFFF	A80000 to A9FFFF	AA0000 to ABFFFF	AC0000 to ADFFFF	AE0000 to AFFFFF
6	900000 to 91FFFF	920000 to 93FFFF	940000 to 95FFFF	960000 to 97FFFF	980000 to 99FFFF	9A0000 to 9BFFFF	9C0000 to 9DFFFF	9E0000 to 9FFFFF
7	800000 to 81FFFF	820000 to 83FFFF	840000 to 85FFFF	860000 to 87FFFF	880000 to 89FFFF	8A0000 to 8BFFFF	8C0000 to 8DFFFF	8E0000 to 8FFFFF

† All addresses shown are in Hexadecimalformat

‡ Rack 0 is the CPU rack.

Note that GE Fanuc Series 90-70 modules will not respond to the user defined address space listed in the tables. For short access AM codes, 29H and 2DH, address range 5000H through FFFFH is user definable for each rack. For example, two 3rd party modules responding to AM code 29H and address 5000H through 7000H will not conflict if they reside in different racks.

The user definable address space for standard access AM code 39H is 100000H through 7FFFFFFH. This address space is available in rack 0 only. For example, a 3rd party module responding to address 100000H through 200000H must reside in rack 0.

An AM code not used by GE Fanuc Series 90-70 modules is 3DH. Therefore, 3rd party modules configured to respond only to standard access AM code 3DH and address range 000000H through FFFFFFFH will *never* interfere with GE Fanuc Series 90-70 modules. 3rd party modules configured to respond to 3DH *must* reside in the main rack.

Modules with large address space requirements are permitted in the Series 90-70 PLC system. They will simply occupy the address allocation for more than one slot. Care must be taken to assure that no GE Fanuc Series 90-70 modules reside in slots that a 3rd party module's address covers. For example, consider a module requiring 1Mbyte of standard access AM code 39H address space. This module can be located in rack 1 and configured to respond to address E00000H through EFFFFFFH. In this case, no Series 90-70 modules may reside in rack 1. Refer to Appendix C for configuration examples.

## Expansion Rack Considerations

Expansion racks are addressed differently for short access AM codes than they are for standard access AM codes. For short access the rack is addressed by the AM code. Tables 3-4 and 3-5 give the AM codes that the module must be configured to respond to and that must be programmed in the function block AM parameter (see Chapter 5, Programming Considerations) to select an expansion rack for short access. For standard access (AM code 39H) the address alone selects the expansion rack and slot (refer to Table 3-3).

For example, consider a Series 90-70 PLC system containing two 3rd party modules; one configured to respond to short access AM code 2DH address 3000H through 4FFFH resides in rack 5, and one which responds to standard access AM code 39H address EC0000H through EFFFFFFH residing in rack 1. Note that GE Fanuc developed Series 90-70 modules must not be in slots 6, 7, 8, and 9 in rack 5, and slots 8 and 9 in rack 1.

The following function block parameters must be programmed to address the module residing in rack 5 configured for short access AM code 2DH:

- AM code 12H
- desired address within range 3000H through 4FFFH

The following function block parameters must be programmed to address the module residing in rack 1 configured for standard access AM code 39H:

- AM code 39H
- desired address within range EC0000H through EFFFFFFH

**Table 3-4. Programmed AM Codes for Short Non-Privileged Access code 29H**

Rack	Programmed AM Code	Board Configured AM Code
0 †	29H	29H
1	1EH	29H
2	1DH	29H
3	1CH	29H
4	1BH	29H
5	1AH	29H
6	19H	29H
7	18H	29H
reserved	1FH	

† Rack 0 is the CPU Rack

Table 3-5. Programmed AM Codes for Short Supervisory Access AM Code 2DH

Rack	Programmed AM Code	Board Configured AM Code
0 †	2DH	2DH
1	16H	2DH
2	15H	2DH
3	14H	2DH
4	13H	2DH
5	12H	2DH
6	11H	2DH
7	10H	2DH
reserved	17H	

† Rack 0 is the CPU Rack.

### Bus Width Compatibility

The Series 90-70 VME backplane uses the J1 connector only; therefore the maximum number of address and data bits the backplane can support is:

- 24 address bits
- and

- 16 data bits

With this restriction the Series 90-70 PLC system can support modules which use:

- 16 address and 16 or 8 data bits
- and
- 24 address and 16 or 8 data bits

### VMEbus Clock and System Functions

The Series 90-70 PLC system provides the VMEbus clock and bus controller functions. VME modules which include this capability should have them disabled. The Series 90-70 PLC power supply generates the necessary power sequencing signals such as ACFAIL and SYSRESET. VME modules providing these functions must have them disabled. VME modules must *not* assert these signals under any condition.

## VME Interrupts

The Series 90-70 PLC CPU handles VME interrupts IRQ5, IRQ6, and IRQ7. 3rd party VME modules *must not* service these interrupts. Third party VME modules may interrupt each other on IRQ1, IRQ2, IRQ3, or IRQ4. Third party VME modules may interrupt the Series 90-70 PLC CPU on IRQ6. See *Interrupting the PLC CPU* (page 3-21) for more information on interrupting the PLC CPU on IRQ6.

If a 3rd Party VME module is physically located to the left of a module that can generate interrupts, then the 3rd Party VME module must pass the VME interrupt acknowledge daisy chain to the slot on the right. If the 3rd Party VME module does not pass the VME interrupt acknowledge daisy chain to the right, then it must be physically located to the right of all modules that can generate VME interrupts.

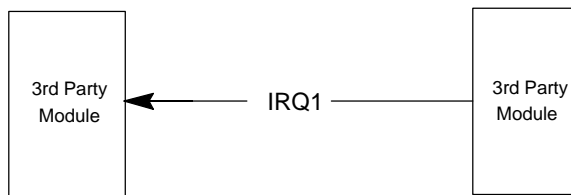

Figure 3-1. VME Interrupts between 3rd Party Modules

When an interrupt is used between 3rd party VME modules, only interrupts IRQ1 through IRQ4 can be used, and one of the modules must be the interrupt handler. This avoids interference with the processing of interrupts by the Series 90-70 PLC CPU. Special backplane jumpers must be installed in those slots which have VME modules that either generate or handle these interrupts (IRQ1 – IRQ4).

A list of these jumpers and their functions can be found in Table F-1 in Appendix F.

## Slot Location Considerations for VME Modules

Use the following guidelines to determine the slot location of VME modules in a Series 90-70 PLC system. The Series 90-70 PLC system has two types of racks, standard racks and VME Integrator racks.

### Standard Series 90-70 Racks and VME Integrator racks

To avoid potential problems with 3rd party modules which may not pass the VME daisy chain signals, the following guidelines are suggested.

- All Series 90-70 PLC modules should occupy lower numbered (that is, the leftmost) slots in the rack. All 3rd party VME modules must be installed to the right of the Series 90-70 PLC modules.
- There must not be any unused slots between Series 90-70 modules in the rack. Similarly, there must not be any unused slots between VME modules which must interrupt each other. And there must not be any unused slots between the PLC CPU and a VME module which handles interrupts. If an unused slot between modules is required (for example, to accommodate an over-wide module) a connector which daisy chains the interrupt signals must be used.

### VME Integrator Racks

- VME modules can be installed in any module slot (2PL - 9PL and 12PL - 19PL).
- Series 90-70 modules, when installed in a VME Integrator Rack, can only occupy slots 2PL - 9PL) since they require two VME slots. Jumpers on the backplane are configurable to allow the SYSFAIL signal to be enabled or disabled; to allow the LWORD signal to be inactive; to configure IRQ1/ - IRQ4/ signals for VME slots 12PL to 19PL; and to configure the Bus Grant signals for VME slots 12PL to 19PL.

### Note

3rd Party VME modules CANNOT be installed in a remote I/O system controlled by the Series 90-70 Remote I/O Scanner. The 3rd Party VME modules cannot communicate with the Series 90-70 CPU from a remote system since the VME instructions cannot be executed over the Genius I/O communications link.

## VME Module Configuration

When any features beyond the standard VME read and write function blocks are being used in conjunction with a 3rd Party VME module, the module must be specified in the Logicmaster 90-70 or CIMPLICITY Control I/O configuration. There are six mutually exclusive configuration modes for 3rd Party VME modules. Table 3-6 summarizes each of the configuration modes.

**Table 3-6. Modes of Configuration for 3rd Party VME Modules**

<b>Mode</b>	<b>Description</b>
None	The configuration of the module is used only as a placeholder.
Interrupt Only	The module will interrupt the PLC CPU to trigger logic execution.
Bus Interface	The module's memory is configured to be accessed via the VME config read and VME config write function blocks. In addition, the module may interrupt the PLC CPU to trigger logic execution.
FullMail	For use with the GE Fanuc Plug & Play PC Coprocessor.
ReducedMail	This mode is not yet supported by the PLC CPU.
I/Oscan	For use with the Series 90-70 Thermocouple Input module, catalog number HE697THM160.

If your particular application does not require any of the 3rd Party VME features provided by the PLC CPU or it is just using the standard VME read and VME write function blocks, then configuring the module in the rack/slot configuration is not required. Even if the configuration of the module is not required, you may wish to include the module in the configuration for documentation or configuration error checking purposes. Use the **NONE** configuration mode in this case. A 3rd party VME module with configuration mode **NONE** acts as a placeholder within the rack/slot configuration.

If your application does require use of a 3rd Party VME feature provided by the PLC CPU, then you are required to specify the module in the I/O configuration. Table 3-7 summarizes which configuration modes can be used with each of the particular PLC CPU features for 3rd Party VME Modules.

Table 3-7. Third Party VME Features vs. Configuration Modes

Feature	Configuration Modes
VME Read and VME Write Function Blocks (Chapter 5, pages 5-1 through 5-13)	None, Bus Interface, Interrupt Only, Full Mail, and I/O Scan (all modes)
VME Config Read and VME Config Write Function Blocks (Chapter 5, pages 5-14 through 5-17)	Bus Interface
Interrupting the PLC CPU (see page 3-21)	Interrupt Only and Bus Interface
Plug and Play PC Coprocessor module	Full Mail
Series 90-70 Thermocouple Input module	I/O Scan

### Configuring 3rd Party Modules with Logicmaster 90-70

#### Note

For information on configuration using CIMPLICITY Control programming software, refer to the CIMPLICITY Control online help.

*Note that the information in this paragraph applies to both Logicmaster 90-70 and CIMPLICITY Control programming software. There is one selection available for foreign VME modules in the I/O configuration software: 3RD PTY VME which is found under the VME menu. When 3RD PTY VME is selected, six modes of configuration are available (which are described above). If a 3rd Party VME module is placed to the left of a module that can generate interrupts, then it is assumed that the 3rd Party VME module passes the VME interrupt acknowledge daisy chain to the slot on the right. If the module does not pass the VME interrupt acknowledge daisy chain, then it must be placed to the right of all modules that can generate VME interrupts. The configuration software will flag an error if an empty slot is located to the left of a module which can generate interrupts.*



## Configuring a VME Module

To configure a VME module on the I/O Configuration Rack screen:

1. Move the cursor to the desired rack and slot location. The slot may be either unconfigured or previously configured.

### Note

When configuring the VME module in a VME Integrator Rack, the half-slot screen for a particular slot is displayed. This allows you to configure the half slots of that slot. The remainder of the configuration process is the same for the VME Integrator Rack as it is for a standard I/O rack.

2. Press VME (F7) and then VME (F1) from the I/O Configuration Rack screen to display a list of available modules.

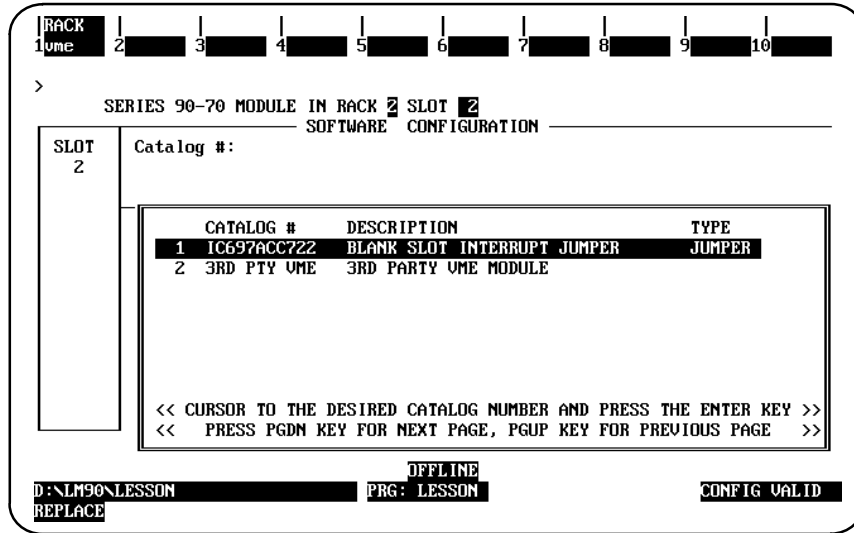

3. Position the cursor on the 3RD PARTY VME module, and press the Enter key to display the detail screen for that module.

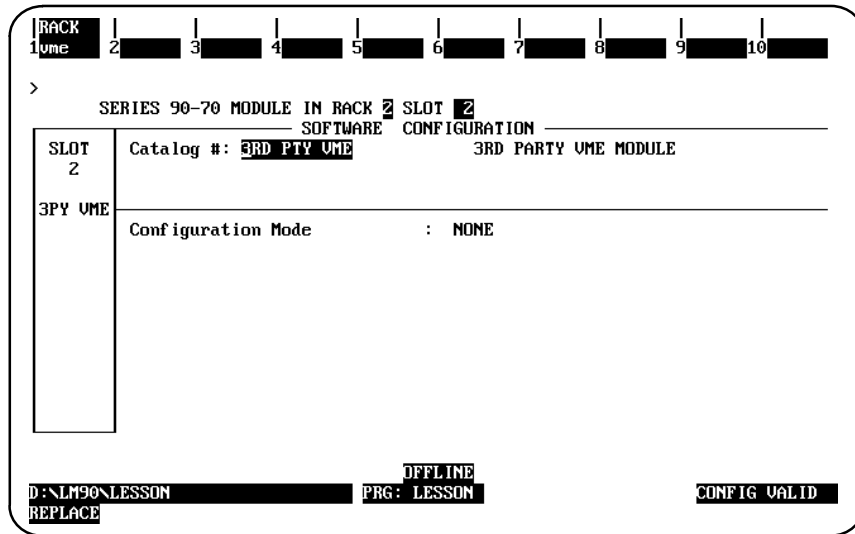

### Selecting the Configuration Mode

The configuration mode specifies how the module will be accessed. The configuration mode is selected in the **Configuration Mode** field on the module detail screen.

1. To select a different configuration mode, move the cursor to the **Configuration Mode** field and repeatedly press the Tab key until the desired mode is displayed on the screen. Then, press the Enter key.
2. Configure the module. Then, press Rack (Shift-F1) or the Escape key to return to the rack display.

### None Mode

When **NONE** mode is selected, the following VME detail screen is displayed.

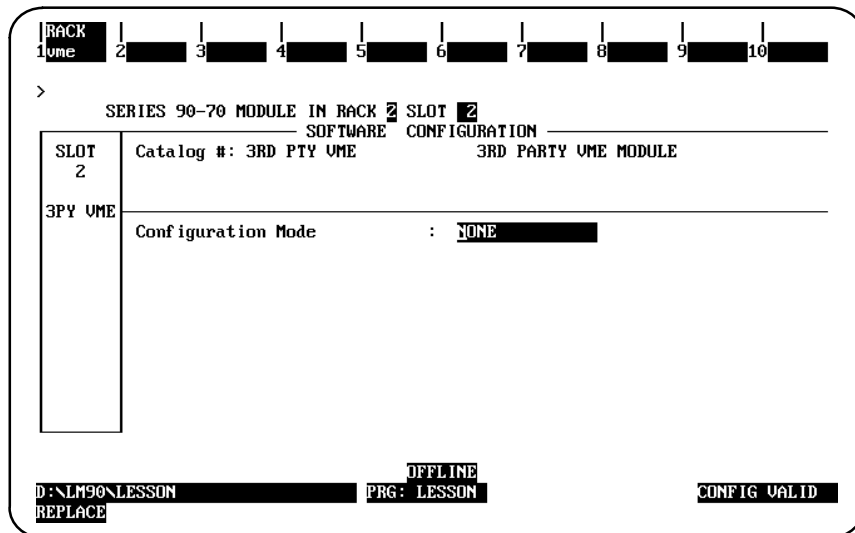

The configuration mode on this screen is set to **NONE**. There are no other parameters to be selected.

## Interrupt Only Mode

### Note

**INTERRUPT ONLY** mode is not supported by a Release 6 or earlier CPU.

When **INTERRUPT ONLY** mode is selected, the following VME detail screen is displayed.

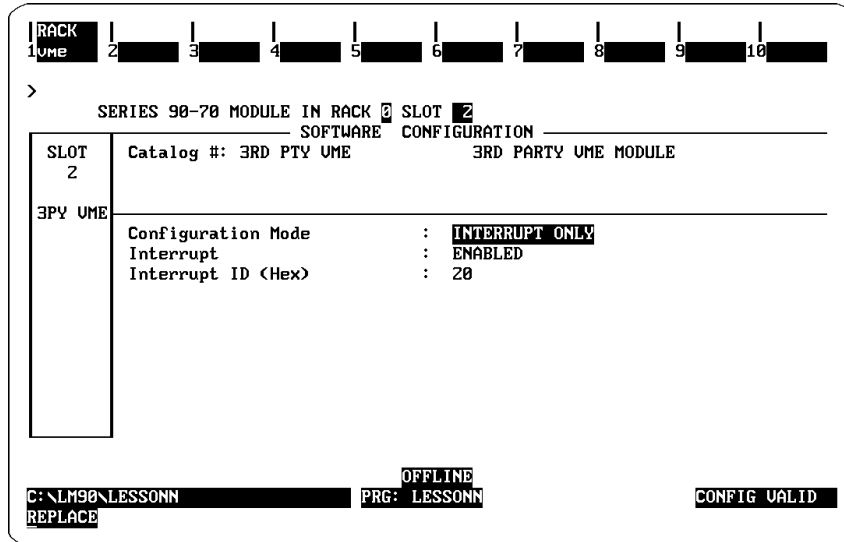

Table 3-8. Parameters for INTERRUPT ONLY Configuration Mode

Parameter	Description
ConfigurationMode	The configuration mode is set to <b>INTERRUPT ONLY</b> .
Interrupt	Select whether the interrupt is to be <b>ENABLED*</b> or <b>DISABLED</b> . If <b>ENABLED</b> , then PLC CPU will execute logic when the interrupt arrives. If <b>DISABLED</b> , the PLC CPU will not execute logic when the interrupt arrives.
Interrupt ID	A byte hexadecimal value which identifies the module driving the interrupt line. The value in this field must either be in the form <i>slot:rack</i> , based on the rack and slot the module is in, or a value in the range F0 to FE hex. For example, if a VME module is configured in slot 3 of rack 0, a value of 30 (30H; slot 3 rack 0) is displayed. Each VME module configured within the system must have a different interrupt ID.  The default value must be a value based on the rack and slot the module is in. The first half-slot configured for a slot (either A or B) will be assigned the slot:rack ID; the second half-slot configured for the slot (either A or B) will be in the range <b>F0 - FE</b> . The PLC CPU does not support interrupts from modules in slot B.

\* Default selection.

## Bus Interface Mode

### Note

**BUS INTERFACE** mode is supported by Release 4 and later CPUs. When **BUS INTERFACE** mode is selected, the following VME detail screen is displayed.

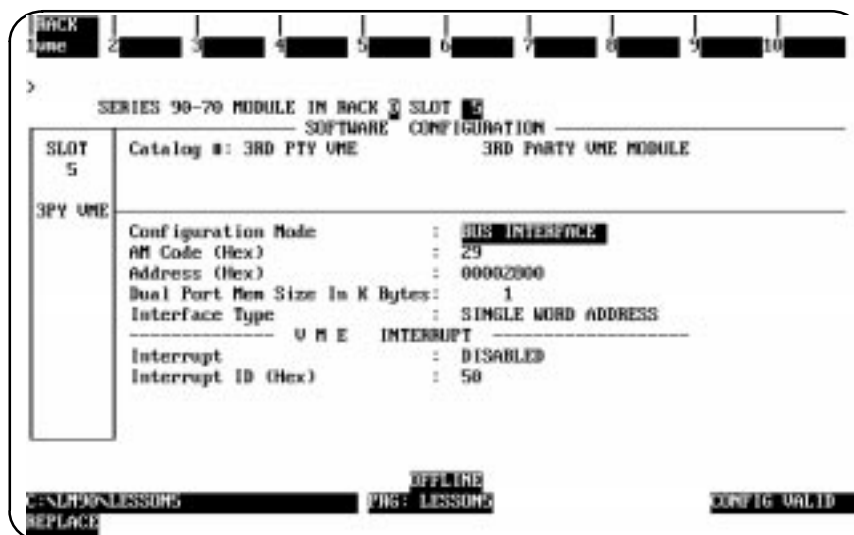

Table 3-9. Parameters for BUS INTERFACE Configuration Mode

Parameter	Description
Configuration Mode	The configuration mode is set to <b>BUS INTERFACE</b> .
AddressModifier Code	The memory space (in hexadecimal) on the VME bus that the module responds to. Choices are: 09H = extended non-privilege data access. 0AH = extended non-privilege program access. 0DH = extended supervisory data access. 0EH = extended supervisory program access. 29H* = short non-privilege access. 2DH = short supervisory access. 39H = standard non-privilege data access. 3AH = standard non-privilege program access. 3DH = standard supervisory data access. 3EH = standard supervisory program access.
Address	A 16-bit, 24-bit, or 32-bit hexadecimal value, depending on the AM mode selected. If the AM code is 29H or 2DH, the address range must be a 16-bit value, 0000 to 0000FFFF. If the AM code is 39H, 3AH, 3DH, or 3EH, the address range must be a 24-bit value, 0000 to 00FFFFFF. If the AM code is 09H, 0AH, 0DH, or 0EH, the address range must be a 32-bit value, 0000 to FFFFFFFF. (Although the Series 90-70 I/O rack does not contain the P2 backplane, the upper eight address lines of the 32-bit address can be jumpered to a fixed value on the module.) Default = 0000FFFF.

**Table 3-9. Parameters for BUS INTERFACE Configuration Mode – Continued**

Parameter	Description
Dual Port Memory Size in K Bytes	The size of the dual port memory (in 1K increments) for the VME module. Values are 1* to 16,384.
Interface Type	Specify how data is to be read/written to the VME module. Choices are: <b>WORD ACCESS:</b> Data is to be read/written a word at a time to consecutive addresses. <b>BYTE ADDRESS:</b> Data is to be read/written a byte at a time to consecutive addresses. <b>ODD BYTE ONLY:</b> Data is to be read/written only to odd bytes because the hardware cannot support even addresses. <b>SINGLE WORD ADDRESS:</b> also called same address. Data is to be read a word at a time from the same address on the ME bus into PLC memory and written a word at a time from consecutive words in PLC memory to the same address. <b>SINGLE BYTE ADDRESS:</b> Data is to be read a byte at a time from the same address on the VME bus into PLC memory and written a byte at a time from consecutive words in PLC memory to the same address.
Interrupt	Select whether the interrupt is to be <b>ENABLED*</b> or <b>DISABLED</b> . If <b>ENABLED</b> , the PLC CPU will execute logic when the interrupt arrives. If <b>DISABLED</b> , the PLC CPU will not execute logic when the interrupt arrives.
Interrupt ID	A byte hexadecimal value which identifies the module driving the interrupt line. The value in this field must either be in the form <i>slot:rack</i> , based on the rack and slot the module is in, or a value in the range F0 to FE hex. For example, if a VME module is configured in slot 3 of rack 0, a value of 30 (30H; slot 3 rack 0) is displayed. Each VME module configured within the system must have a different interrupt ID.  The default value must be a value based on the rack and slot the module is in. The first half-slot configured for a slot (either A or B) will be assigned the slot:rack ID; the second half-slot configured for the slot (either A or B) will be in the range F0 - FE. The PLC CPU does not support interrupts from modules in slot B.

\* Default selection.

## Full Mail Mode

### Note

FULL MAIL mode is supported by Release 5.5 and later CPUs.

When FULL MAIL mode is selected, the following VME detail screen is displayed.

```
BACK | 1 | 2 | 3 | 4 | 5 | 6 | 7 | 8 | 9 | 10 |
time  |  |  |  |  |  |  |  |  |  |  |

>
SERIES 90-70 MODULE IN RACK 2 SLOT 2
SOFTWARE CONFIGURATION
-----
SLOT 2 Catalog #: 3RD PTY VME 3RD PARTY VME MODULE
3PY VME
-----
Configuration Mode      : FULL MAIL
High Priority Mail      : ENABLED
Interrupt ID (Hex)     : 22
AM Code (Hex)          : 39
Address (Hex)          : 00E00000
Dual Port Mem Size In K Bytes: 16

OFFLINE
D:\LM90\LESSON PRG: LESSON CONFIG VALID
REPLACE
```

Table 3-10. Parameters for FULL MAIL Configuration Mode

Parameter	Description
Configuration Mode	The configuration mode is set to <b>FULL MAIL</b> .
High Priority Mail	Select whether high priority mail is to <b>ENABLED*</b> or <b>DISABLED</b> . The PLC CPU requires this parameter to be set to <b>ENABLED</b> .
Interrupt ID	<p>A byte hexadecimal value which identifies the module driving the interrupt line. The value in this field must either be in the form <i>slot:rack</i> based on the rack and slot the module is in, or a value in the range F0 to FE hex. For example, if a VME module is configured in slot 3 of rack 0, a value of 30 (30H; slot 3 rack 0) is displayed. Each VME module configured within the system must have a different interrupt ID.</p> <p>The default value must be a value based on the rack and slot the module is in. The first half-slot configured for a slot (either A or B) will be assigned the slot:rack ID; the second half-slot configured for the slot (either A or B) will be in the range F0 - FE. The PLC CPU does not support <b>FULLMAIL</b> modules in slot B.</p>
Address Modifier Code	<p>The memory space (in hexadecimal) on the VME bus that the module responds to. In rack zero, the choices are:</p> <ul style="list-style-type: none"> <li>09H = extended non-privilege data access.</li> <li>0AH = extended non-privilege program access.</li> <li>0DH = extended supervisory data access.</li> <li>0EH = extended supervisory program access.</li> <li>39H* = standard non-privilege data access.</li> <li>3AH = standard non-privilege program access.</li> <li>3DH = standard supervisory data access.</li> <li>3EH = standard supervisory program access.</li> </ul> <p>In racks 1 - 7, the AM code must be 39H.</p>
Address	<p>A 16-bit, 24-bit, or 32-bit hexadecimal value, depending on the AM code selected. In rack zero, for 24-bit addressing modes where the AM code is 09H, 0AH, 0DH, or 0EH, the address must be xxxx0000H. For 32-bit addressing modes where the AM code is 39H, 3AH, 3DH, or 3EH, the address must be 00xx0000H. (Default = 00100000H)</p> <p>In racks 1 - 7, the address must be 00xx0000H. Default = 10000H *  <math display="block">(((10H - \text{rack}) * 10H) + (2 * (\text{slot} - 2)))</math></p> <p>The hexadecimal digits represented by x may have any value from 0 through F, inclusive.</p> <p>Although the Series 90-70 I/O rack does not contain the P2 backplane, the upper eight address lines of the 32-bit address can be jumpered to a fixed value on the module.</p>
Dual Port Memory Size in K Bytes	The size of the dual port memory (in 1K increments) for the VME module. Values are 16* to 16,384.

\* Default selection.

## Reduced Mail Mode

### Note

REDUCED MAIL mode is not yet supported by the PLC CPU.

When REDUCED MAIL mode is selected, the following VME detail screen is displayed.

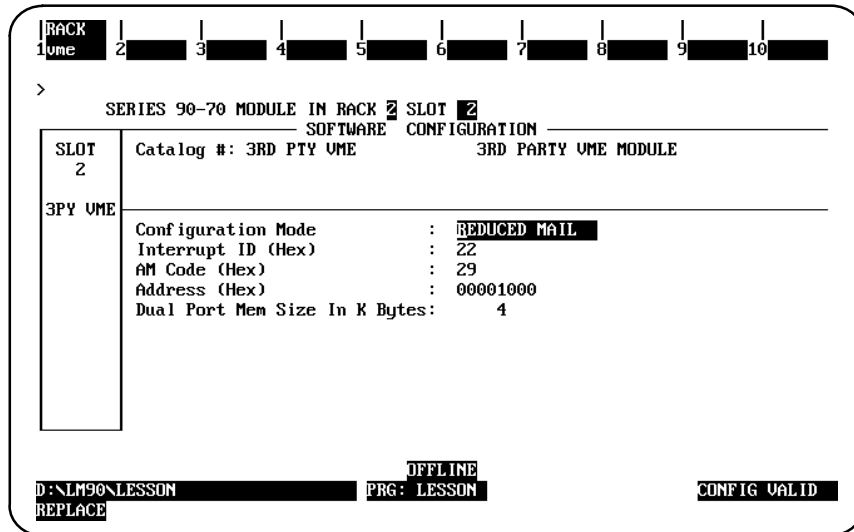



Table 3-11. Parameters for REDUCED MAIL Configuration Mode

Parameter	Description
Configuration Mode	The configuration mode is set to <b>REDUCED MAIL</b> .
Interrupt ID	A byte hexadecimal value which identifies the module driving the interrupt line. The value in this field must either be in the form <i>slot:rack</i> based on the rack and slot the module is in, or a value in the range F0 to FE hex. For example, if a VME module is configured in slot 3 of rack 0, a value of 30 (30H; slot 3 rack 0) is displayed. Each VME module configured within the system must have a different interrupt ID. The default value must be a value based on the rack and slot the module is in. The first half-slot configured for a slot (either A or B) will be assigned the slot:rack ID; the second half-slot configured for the slot (either A or B) will be in the range <b>F0 - FE</b> . The PLC CPU does not support interrupts from modules in slot B.
Address Modifier Code	The memory space (in hexadecimal) on the VME bus that the module responds to. Choices are:  <b>09</b> = extended non-privilege data access. <b>0A</b> = extended non-privilege program access. <b>0D</b> = extended supervisory data access. <b>0E</b> = extended supervisory program access. <b>29*</b> = short non-privilege access. <b>2D</b> = short supervisory access. <b>39</b> = standard non-privilege data access. <b>3A</b> = standard non-privilege program access. <b>3D</b> = standard supervisory data access. <b>3E</b> = standard supervisory program access.
Address	A 16-bit, 24-bit, or 32-bit hexadecimal value, depending on the AM mode selected. If the AM code is <b>29</b> or <b>2D</b> , the address range must be a 16-bit value, 0000 to 0000FFFF. If the AM code is <b>39</b> , <b>3A</b> , <b>3D</b> , or <b>3E</b> , the address range must be a 24-bit value, 0000 to 00FFFFFF. If the AM code is <b>09</b> , <b>0A</b> , <b>0D</b> , or <b>0E</b> , the address range must be a 32-bit value, 0000 to FFFFFFFF. (Although the Series 90-70 I/O rack does not contain the P2 backplane, the upper eight address lines of the 32-bit address can be jumpered to a fixed value on the module.) Default = 0000FFFF.
Dual Port Memory Size in K Bytes	The size of the dual port memory (in 1K increments) for the VME module. Values are <b>4*</b> to <b>16,384</b> .

\* Default selection.

# I/O Scan Mode

## Note

I/O SCAN mode is supported by Release 5.5 and later CPUs.

When I/O SCAN mode is selected, the following VME detail screen is displayed.

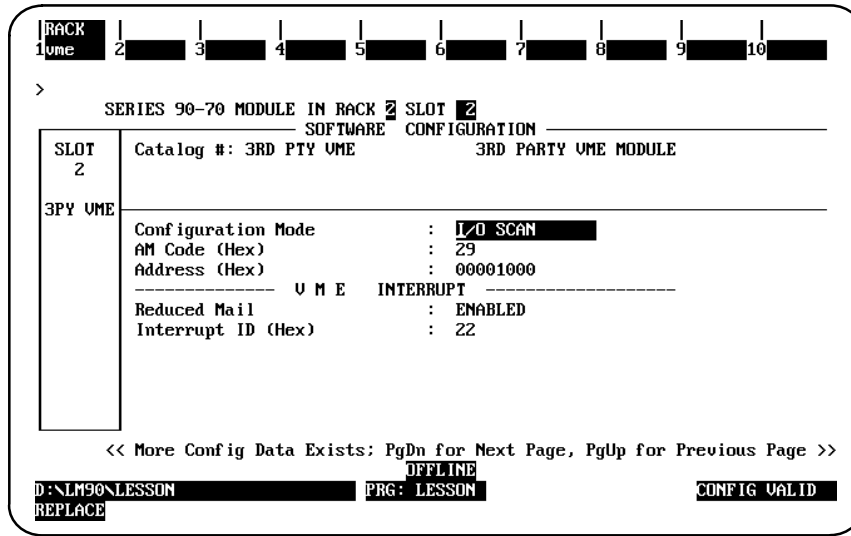

Press the Page Down key to display the reference address parameters.

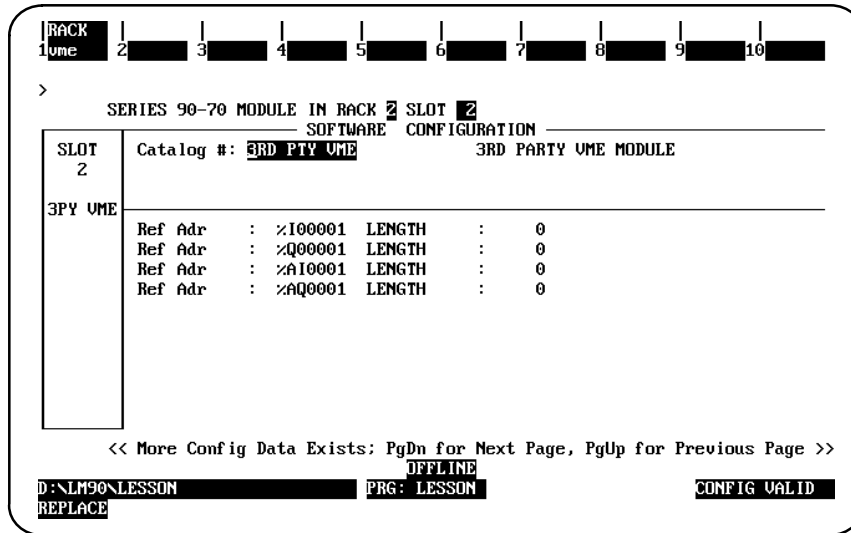

Table 3-12. Parameters for I/O Scan Configuration Mode

Parameter	Description
Configuration Mode	The configuration mode is set to <b>I/O SCAN</b> .
AddressModifier Code	<p>The memory space (in hexadecimal) on the VME bus that the module responds to. Choices are:</p> <p><b>09H</b> = extended non-privilege data access.  <b>0AH</b> = extended non-privilege program access.  <b>0DH</b> = extended supervisory data access.  <b>0EH</b> = extended supervisory program access.  <b>29H*</b> = short non-privilege access.  <b>2DH</b> = short supervisory access.  <b>39H</b> = standard non-privilege data access.  <b>3AH</b> = standard non-privilege program access.  <b>3DH</b> = standard supervisory data access.  <b>3EH</b> = standard supervisory program access.</p>
Address	A 16-bit, 24-bit, or 32-bit hexadecimal value, depending on the AM mode selected. If the AM code is <b>29H</b> or <b>2DH</b> , the address range must be a 16-bit value, 0000 to 0000FFFF. If the AM code is <b>39H</b> , <b>3AH</b> , <b>3DH</b> , or <b>3EH</b> , the address range must be a 24-bit value, 0000 to 00FFFFFF. If the AM code is <b>09H</b> , <b>0AH</b> , <b>0DH</b> , or <b>0EH</b> , the address range must be a 32-bit value, 0000 to FFFFFFFF. Default = (slot * 2K).
ReducedMail	Select whether high priority mail is to be <b>ENABLED*</b> or <b>DISABLED</b> . If <b>ENABLED</b> , the PLC CPU will send and receive high priority mail from this module.
Interrupt ID	<p>A byte hexadecimal value which identifies the module driving the interrupt line. The value in this field must either be in the form <i>slot:rack</i> based on the rack and slot the module is in, or a value in the range F0 to FE hexadecimal. For example, if a VME module is configured in slot 3 of rack 0, a value of 30 (30H; slot 3 rack 0) is displayed. Each VME module configured within the system must have a different interrupt ID.</p> <p>The default value must be a value based on the rack and slot the module is in. The first half-slot configured for a slot (either A or B) will be assigned the slot:rack ID; the second half-slot configured for the slot (either A or B) will be in the range <b>F0 - FE</b>.</p> <p>The PLC CPU does not support <b>I/O Scan</b> modules in slot B.</p>
Reference Address/Length	The %I, %Q, %AI, and %AQ offsets and lengths that will be scanned by the PLC. For %I and %Q, the valid range is from 0 to 16 bytes. For %AI and %AQ, the valid range is from 0 to 64 words.

\* Default selection.

## Interrupting the PLC CPU

Third party VME Modules may interrupt the Series 90-70 PLC CPU on IRQ6 to trigger the execution of logic in the Series 90-70 application program. Each interrupt can be used to trigger one LD interrupt block and up to the maximum number of standalone programs. CIMPLICITY Control (version 2.00 or higher) is required to use this feature. Also, CPU version 7.10 or higher is required.

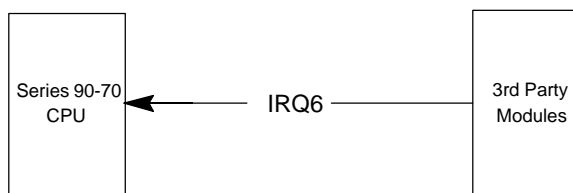

Figure 3-2. VME Interrupts from 3rd Party Modules

## Module Requirements

Third Party VME modules being used to interrupt the Series 90-70 PLC CPU must meet the following requirements.

### IRQ6

Third Party VME modules may only use IRQ6 to interrupt the PLC CPU. The module must release IRQ6 as soon as the PLC CPU completes the VME interrupt acknowledge cycle. If the module does not release IRQ6 immediately upon the acknowledge, then the PLC CPU will interpret this as a subsequent interrupt request and be forced to service the VME interrupt again. If this condition persists, the recurring interrupts could starve all of the other processes running in the PLC CPU and eventually cause the PLC system watchdog timer to expire. An expired watchdog timer will send the CPU to STOP/HAUT mode.

### Interrupt ID

When the 3rd Party VME module generates a VME interrupt, it must present an interrupt id during the interrupt acknowledge cycle. The id that the module presents is a byte value which must be either the binary coded decimal representation slot:rack (based on its physical location in the system) or a value between 0F0 and 0FEH. For example, if the VME module is placed in slot 5 of rack 1, its default interrupt id would be 51H (slot 5 rack 1). Alternatively, the module could use the value FBH as long as no other module in the system will use that value. It is acceptable for the interrupt id to be configurable either with hardware jumpers or with a VME write from within the application program.

### Dual Port Memory

Third Party VME modules being used to interrupt the Series 90-70 PLC CPU may optionally have dual port memory. This memory can be accessed by using the VME read or VME write function blocks. The VME address for the dual port memory must fit the allocation requirements described in pages 3-1 through 3-5.

## Module Configuration

Third party VME modules that will be used to interrupt the PLC CPU must be specified in the CIMPLICITY Control rack/slot configuration. To configure a third party VME module, chose Add Module from the Edit->Module Operations menu, select the VME tab from the Module Catalog, and then select 3rd Party VME. Third party VME modules may be placed in the main rack or in expansion racks. When using the Integrator's rack, 3rd Party VME modules used to interrupt the PLC CPU may only reside in a slot A; they may not be used in a slot B. Once the 3rd Party VME module is added, a parameters dialog with the following three parameters will appear.

### Configuration Mode

There are six mutually exclusive configuration modes for third party VME modules. The two valid configuration modes for interrupting the PLC CPU are **Interrupt Only** and **Bus Interface**. Although VME interrupts can be generated by 3rd party modules using other configuration modes (such as Full Mail and I/O Scan), those interrupts are used strictly for high priority mail messages. They cannot be used to trigger the execution of a block or program.

### Interrupt

This parameter is used to mask the interrupt from this 3rd Party VME module. When this parameter is set to *Enabled*, the PLC CPU will process the interrupt from this module and schedule the associated block and programs for execution. When this parameter is set to *Disabled*, the PLC CPU will process the interrupt from this module but will **not** schedule the associated block or programs for execution. When the interrupt is *Disabled* in the rack/slot configuration, it cannot be unmasked via Service Request Function Block #17.

### Interrupt ID (Hex)

Each VME module in the system (3rd Party or otherwise) must have a unique interrupt identifier. The interrupt identifier is a byte hexadecimal value which identifies the module driving the interrupt line and must be entered on the configuration screen. The 3rd Party VME module may either use its physical location (slot:rack) or an unused value between F0 and FE hexadecimal as its interrupt id. For example, if a VME module is configured in slot 3 of rack 0, its default interrupt id would be 30H (slot 3 rack 0). Alternatively, the module could use the value F5H as long as no other module in the system is using that value. (CIMPLICITY Control programming software configuration function will prevent the user from selecting the same interrupt id for more than one module.) Only one interrupt id is allowed for each module. The interrupt id that the module in this rack and slot is using must match the interrupt id entered as this configuration parameter.

## Associating Interrupt with Logic

In addition to configuring the 3rd Party VME module in the rack/slot configuration within CIMPLICITY Control, the association between the interrupt and the block and/or program(s) that are to be executed needs to be specified within the resource editor. CIMPLICITY Control provides a set of pre-defined names which correspond to all of the possible interrupt ids that a 3rd Party VME module could use. Each of these names can be used as the SINGLE input for an IEC task. The form for these names is *VME\_xx*,

where xx is the interrupt id (for example, VME\_30, VME\_F5). The VME\_xx name form is **only** for use with interrupts from 3rd party VME modules. (Series 90-70 discrete and analog interrupts are named by their corresponding %I and %AI references.)

A single interrupt source (that is, one VME\_xx name) can be used as the trigger to multiple IEC tasks with different priorities. However, a single interrupt source can only trigger one LD interrupt block. The VME\_xx variable is not a real physical variable that can be accessed and tested by a program; it is simply a name to satisfy the SINGLE input to the IEC task. *For more information about defining IEC tasks, refer to the CIMPPLICITY Control online help.*

## Frequency and Queuing

The Series 90-70 PLC system allows VME interrupts from discrete, analog, and 3rd Party modules to trigger LD interrupt blocks and standalone programs in the PLC. The queuing and frequency of the 3rd Party interrupts are subject to the same rules that apply to the discrete and analog interrupts. (See *Interrupt Handling* in Chapter 2 in the Series 90-70 Programmable Controller Reference Manual, GFK-0265G, and later revisions for more information.)

## Dynamic Masking of the Interrupt

The Series 90-70 PLC CPU provides a service to dynamically mask and unmask interrupts from 3rd Party VME modules from within the application logic. This operation is analogous to how interrupts from Series 90-70 discrete and analog modules are masked and unmasked via Service Request Function Block #17.

To mask or unmask an interrupt from a 3rd Party VME module, the application logic will pass VME\_3PY\_INT\_ID (17 decimal, 11H) as the memory type and the interrupt id as the offset to SVC\_REQ #17. When the interrupt is not masked, the PLC CPU will process the interrupt and schedule the associated block and programs for execution. When the interrupt is masked, the PLC CPU will process the interrupt but will **not** schedule the associated block or programs for execution. When the interrupt is *Disabled* in the rack/slot configuration, it cannot be unmasked via Service Request Function Block #17. For more information on Service Request Function Block #17, see GFK-0265, the *Series 90-70 Programmable Controller Reference Manual*.

# Chapter 4

## Installation of VME Modules

---

---

### Cooling for Optimum Operation

As indicated previously, if any selected VME modules require forced air for cooling, the installation of fans to ensure that those cooling requirements are met must be done by the user. Additionally, certain industrial applications may require the presence of loss-of-fan detection. Rack Fan Assemblies (IC697ACC721 and IC697ACC724) are available from GE Fanuc as an option for those applications requiring additional cooling.

### Rack Standoffs for J2 Backplane Requirements

When specifying components for those applications requiring the J2 backplane, be aware that many commercially available J2 backplanes have wirewrap pins that extend beyond the Series 90-70 PLC backplane. Subsequent use of the J2 backplane will require that the panel-mount version of the rack be mounted on standoffs attached to the panel to ensure clearance between the wirewrap pins and the panel. Refer to Table 2-3, which lists the items in the VME option kit for mounting a J2 backplane. The front-mount version may use standard rack mounting techniques.

### Grounding Requirements

VME modules used in a Series 90-70 PLC rack must use proper grounding practices. VME modules often use the module front as the ground point with the top and bottom screws which secure the module to the rack as the ground connection. The user should therefore be certain that the mounting screws are securely attached, and the module should not be removed from the rack unless external connections to the module are first removed.

#### Warning

**If the external connections are not removed as described above, potentially hazardous voltages may exist on the module. Additionally, no grounding point exists after the mounting screws have been disconnected.**

### Module Location in Racks

All VME modules installed in a standard Series 90-70 PLC rack should be physically located with consideration for empty slots as described under **Slot Location Considerations for VME modules** in the previous chapter on page 3-5. Location of VME modules in a VME Integrator Rack are also described on that page.

This page intentionally left blank.



# Chapter 5

## Programming Considerations

---

---

This chapter describes the programming functions which allow the Series 90-70 PLC to communicate with 3rd party VME modules. For additional information on Series 90-70 PLC programming, refer to GFK-0263, Logicmaster™ 90 Programming Software User's Manual and GFK-0265, Logicmaster™ 90 Programming Software Reference Manual, or CIMPLICITY Control online help (as applicable to your programming software).

### Programming Functions for Communicating with 3rd Party VME Modules

A group of functions (instructions) is available with Logicmaster 90 software to allow the Series 90-70 PLC CPU to communicate with VME modules obtained from 3rd Party manufacturers. These functions include:

- VME READ (VMERD)
- VME WRITE (VMEWRT)
- VMERead/MODIFY/WRITE(VMERMW)
- VME TEST AND SET (VMETST)
- VME CONFIG READ (VME\_CFG\_RD)
- VME CONFIG WRITE (VME\_CFG\_WRT)
- SWAP

### Byte Significance Convention

When transferring data between the Series 90-70 PLC and a 3rd party VME module, proper consideration must be given to byte significance convention. The Series 90-70 PLC uses the *Intel* convention for storing word data in bytes, that is, the least significant bits (LSB) of a word are stored in the even byte. Many VME modules follow the *Motorola* convention of storing the least significant bits of a word in the odd byte.

The VMEbus access circuitry of the Series 90-70 PLC keeps byte addresses straight, that is, byte address 1 is the same storage location whether accessed from the Series 90-70 PLC or a Motorola convention CPU. However, because of the difference in byte significance, transfers of word and multiword data, for example, 16 bit integers (INT, UINT), 32 bit integers (DINT) or floating point (REAL) numbers, will require adjustment on transfers to or from Motorola convention modules.

In these cases, the two bytes in each word must be swapped, either before or after the transfer (the SWAP function is available for this purpose). In addition, for multiword data items, the words must be swapped end-for-end on a word basis. For example, a 64-bit real number transferred to the Series 90-70 PLC from a Motorola convention module must be byte swapped and word reversed, either before or after reading, as follows:

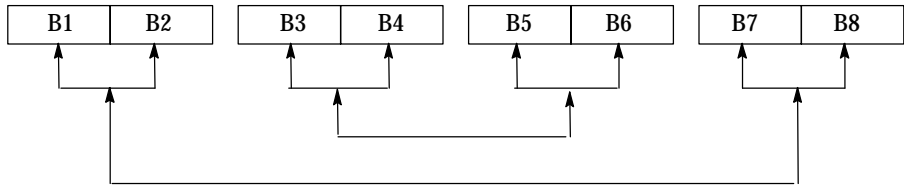

Character (ASCII) strings or BCD data require no adjustment since the Intel and Motorola conventions for storage of character strings are identical.

### VME READ (VMERD)

The VMERD function reads data from the dual-port RAM of VME modules located in the Series 90-70 PLC rack. Typically, these are not GE Fanuc modules, but may include some GE Fanuc modules, such as the Programmable Coprocessor Module (PCM). This function should be executed before the data is needed in the program.

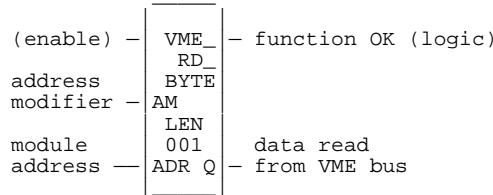

### Parameter Description

- ENABLE:** power flow input which, when energized, enables the execution of the function.
- TYPE:** function type, either BYTE or WORD, to select the corresponding type of VMEbus access to be performed.
- LEN:** internal parameter which specifies the number of bytes or words to be transferred (depends on function type). LEN may be from 1 to 32,767.
- AM:** hexadecimal value coded to specify the rack in which the module resides and the access mode of the VMEbus access to be performed. See Series 90-70 Module Address Allocation on page 3-2.
- ADR:** double word which specifies the hexadecimal address of the first word or byte to be accessed. May be a constant or the reference address of the first (low) word of two words containing the module address. The address is based on the rack and slot the module is located in. See Series 90-70 Module Address Allocation on page 3-2.
- OK:** power flow output which is energized when the function is enabled and the data is successfully read.
- Q:** specifies the first location in the PLC user reference into which the data read from the VME module is to be stored.

When the VMERD function receives power flow through its enable input, the function accesses the VME module at the specified address (ADR) and address modifier (AM) and copies LEN data units (WORDS or BYTES) from the VME module to PLC locations beginning at output reference (Q). The VMERD function passes power to the right via its OK output when its operation is successful.

Refer to Chapter 3 for a discussion on VME module addressing using address and address modifier codes.

## Example of VMERD Function

In the following example, when enabling input %I00001 goes true, 256 bytes of Short space data are read from a module in rack 4, slot 7 into registers %R00001 through %R00128. Unless an error occurs while reading the data, output coil %Q00001 will be set to true.

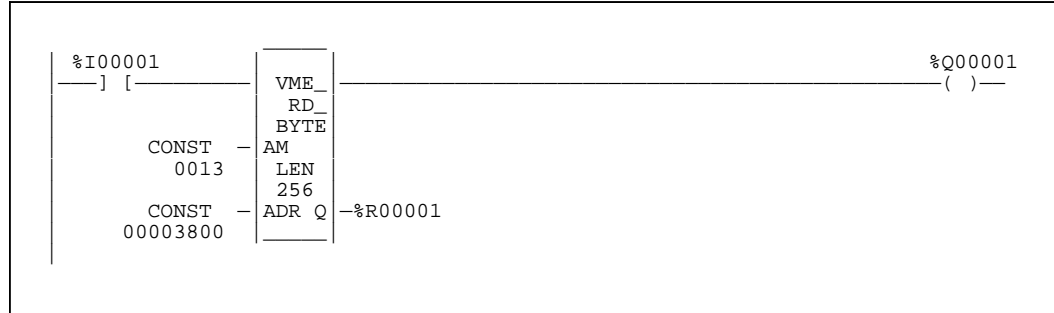

## Entering a VMERD Function

1. Enter enable input permissive logic either before or after selecting the VMERD function. Position the cursor to allow a doubleword function to be entered, that is, allow 2 blank cursor positions to the left of the cursor.
2. Select DATAMV (Shift F6). Select MORE (F9), then VMERD (F1). The screen displays:

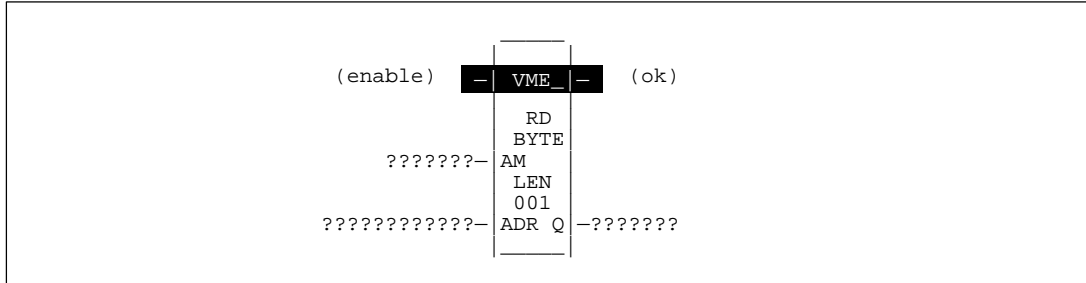

3. The function can read either byte or word data; the default selection is BYTE. If this should be changed to WORD, select TYPES (F10) then WORD (F2).
4. The default data length is 1 (either 1 word or 1 byte). To specify a different amount of data to be read, leave the cursor on the block and type in the number. Press the Enter key.
5. Move the cursor to the left of AM and enter the hexadecimal number that represents the address modifier code. To enter a hexadecimal number, enter a zero, the hexadecimal digits, and the letter H. Press the Enter or Tab key.
6. Move the cursor to the left of ADR and enter either a hexadecimal constant or the beginning (low) reference where the address of the VME module is stored.
7. Move the cursor to the right of Q and enter the beginning (low) output reference to receive the data that is read.
8. If the program should check the execution of the VMERD function, move the cursor to the upper right and enter the appropriate logic.

9. When the rung is complete, use the keypad + or Esc key to accept it.

The following memory types can be used for parameters of the VMERD function:

**Valid Memory Types:**

Parameter	flow	%I	%Q	%M	%T	%S	%G	%R	%P	%L	%AI	%AQ	const	none
enable	•													
AM	•							•	•	•	•	•	•	
ADR	•							•	•	•	•	•	•	
ok	•													•
Q	o	o	o	o	o		o	•	•	•	•	•		

Note: Indirect referencing is available for all register references (%R, %AI, %AQ, %P, and %L)

• = Valid data type, or place where power may flow through the function.

o = Valid reference for BYTE data only.

## VME WRITE (VMEWRT)

The VMEWRT function writes data to the dual-port RAM of VME modules located in the Series 90-70 PLC rack. Typically, these are not GE Fanuc modules, but may include some GE Fanuc modules, such as the PCM. Locate the function at a place in the program where the output data will be ready to send.

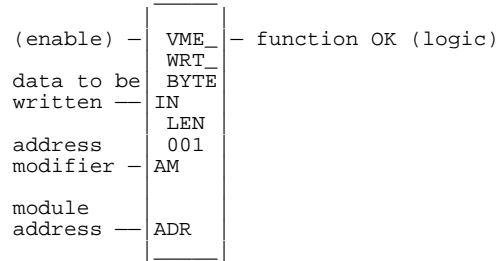

### Parameter Description

- ENABLE:** power flow input which, when energized, enables the execution of the function.
- TYPE:** function type, either BYTE or WORD, to select the corresponding type of VMEbus access to be performed.
- LEN:** internal parameter which specifies the number of bytes or words to be transferred (depends on function type). LEN may be from 1 to 32,767.
- IN:** specifies the first location in the PLC memory where the data to be written to the VME module is stored. This parameter may be a constant, in which case that value is written to all VME addresses covered by the function's length.
- AM:** hexadecimal value coded to specify the rack in which the module resides and the access mode of the VMEbus access to be performed. See Series 90-70 Module Address Allocation on page 3-2.
- ADR:** double word which specifies the hexadecimal address of the first word or byte to be accessed. May be a constant or the reference address of the first (low) word of two words containing the module address. The address is based on the rack and slot the module is located in. See Series 90-70 Module Address Allocation on page 3-2.
- OK:** power flow output which is energized when the function is enabled and completes successfully.

When the VMEWRT function receives power flow through its enable input, the LEN data units from the PLC locations beginning at input reference (IN) are written to the VME module at the specified address (ADR) and address modifier (AM). The VMEWRT function passes power to the right via its OK output when its operation is successful.

See Chapter 3 for a discussion on VME module addressing using address and address modifier codes.

### Example of VMEWRT Function

In the following example, every sweep that enabling input %M00001 is true, the hexadecimal value FFFF is written to each of 20 words on the VME bus, the first (lowest address) being specified by the contents of %R00019 (low word) and %R00020 (high word). Unless an error occurs while writing the data, internal coil %M00055 will be set to true.

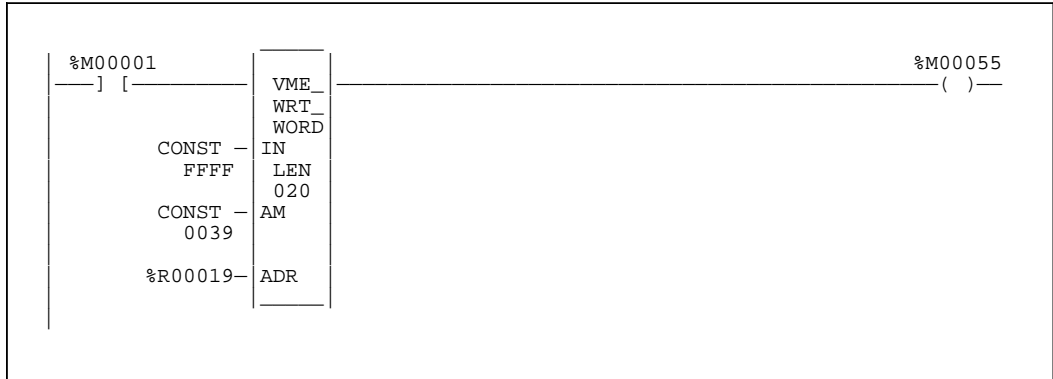

### Entering a VMEWRT Function

1. Enter enable input permissive logic either before or after selecting the VMEWRT function. Position the cursor to allow a doubleword function to be entered, that is, allow 2 empty cursor positions to the left of the cursor.
2. Select DATAMV (Shift F6). Select MORE (F9), then VMEWRT (F2). The screen displays:

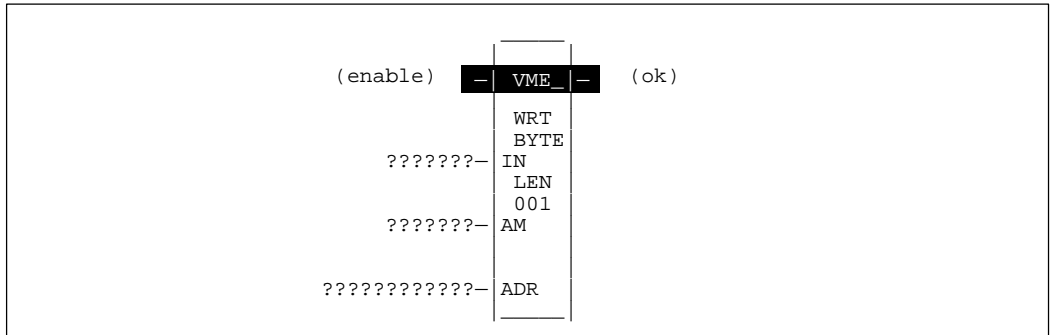

3. The function can write either byte or word data. The default selection is BYTE. If this should be changed to WORD, select TYPES (F10) then WORD (F2).
4. The default data length is 1 (either 1 word or 1 byte). To specify a different amount of data to be written, leave the cursor on the block and type in the number. Press the Enter key.
5. Move the cursor to the left of IN and enter a reference or constant for the data to be written. To enter a hexadecimal number, enter a zero, the hexadecimal digits, and the letter H. Press the Enter or Tab key.
6. Move the cursor to the left of AM and enter the hexadecimal number that represents the address modifier code.

7. Move the cursor to the left of ADR and enter either a hexadecimal constant or the beginning (low) reference where the address of the VME module is stored.
8. If the program should check the execution of the VMEWRT function, move the cursor to the upper right and enter the appropriate logic.
9. When the rung is complete, use the keypad + or Esc key to accept it.

The following memory types can be used for parameters of the VMEWRT function:

**Valid Memory Types:**

Parameter	flow	%I	%Q	%M	%T	%S	%G	%R	%P	%L	%AI	%AQ	const	none
enable	•													
IN	•	o	o	o	o		o	•	•	•	•	•	•	
AM	•	•	•	•	•		•	•	•	•	•	•	•	
ADR	•							•	•	•	•	•	•	
ok	•													•

Note: Indirect referencing is available for all register references (%R, %AI, %AQ, %P, and %L)

• = Valid data type, or place where power may flow through the function.

o = Valid reference for BYTE data only.

## VME READ/MODIFY/WRITE (VMERMW)

The VMERMW function updates a data element in the dual-port RAM of VME modules located in the Series 90-70 PLC rack. Typically, these are not GE Fanuc modules, but may include some GE Fanuc modules, such as the PCM.

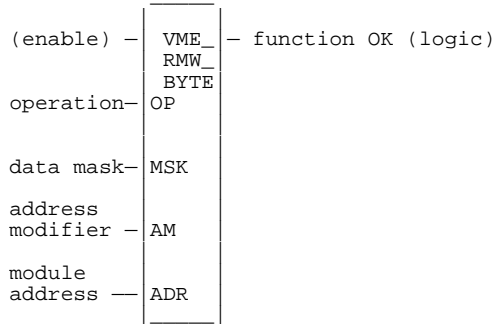

### Parameter Description

- ENABLE:** power flow input which, when energized, enables the execution of the function.
- TYPE:** function type, either BYTE or WORD, to select the corresponding type of VMEbus access to be performed.
- OP:** a constant which specifies whether an AND or OR function is to be used to combine the data and the mask. 0 specifies AND, 1 specifies OR.
- MSK:** a word value containing a mask to be ANDed or ORed with the data read from the bus. If TYPE is BYTE only the low 8 bits of the mask are used.
- AM:** hexadecimal value coded to specify the rack in which the module resides and the access mode of the VMEbus access to be performed. See Series 90-70 Module Address Allocation on page 3-2.
- ADR:** double word which specifies the hexadecimal address of the first word or byte to be accessed. May be a constant or the reference address of the first (low) word of two words containing the module address. The address is based on the rack and slot the module is located in. See Series 90-70 Module Address Allocation on page 3-2.
- OK:** power flow output which is energized when the function is enabled and completes successfully.

When the VMERMW function receives power flow through its enable input, the function reads a word or byte of data from the module at the specified address (ADR) and address modifier (AM). This byte or word of data is combined (AND/OR) with the data mask MSK. Selection of AND or OR is made using the OP input. If byte data is specified, only the lower 8 bits of MSK are used. The result is then written back to the same VME address from which it was read. The VMERMW function passes power flow to the right via its OK output whenever power is received when its operation is successful.

See Chapter 3 for a discussion on VME module addressing using address and address modifier codes.



### Example of VMERMW Function

In the following example, when enabling input %M00044 is energized, the hexadecimal value 80H is ORed with the byte of data read from address 106010H on the VME bus in rack 0 (the main rack); this should be a module in slot 5. Unless an error occurs while accessing the data, coil %Q00027 will be set to true.

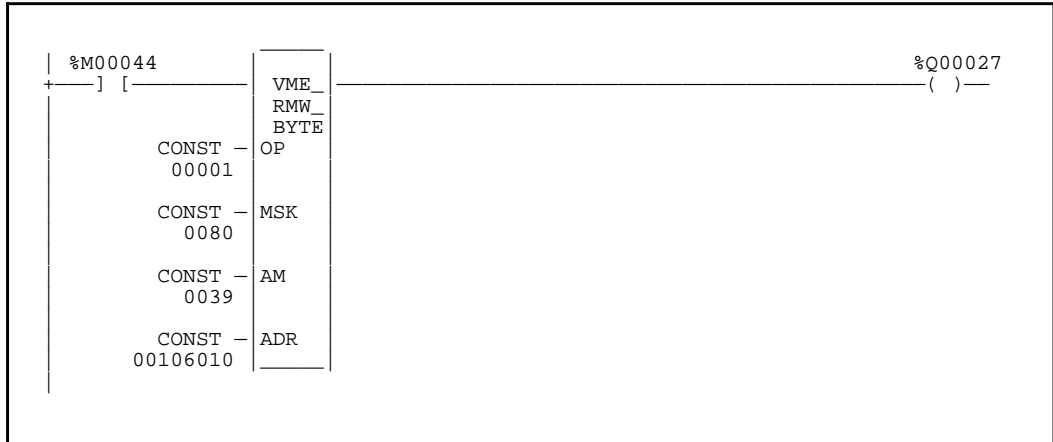

### Entering a VMERMW Function

1. Enter enable input permissive logic before or after selecting VMERMW function. Position cursor to allow a doubleword function to be entered, that is, 2 blank cursor positions to left of cursor.
2. Select DATAMV (shift F6). Select MORE (F9), then VMERMW (F3). The screen displays:

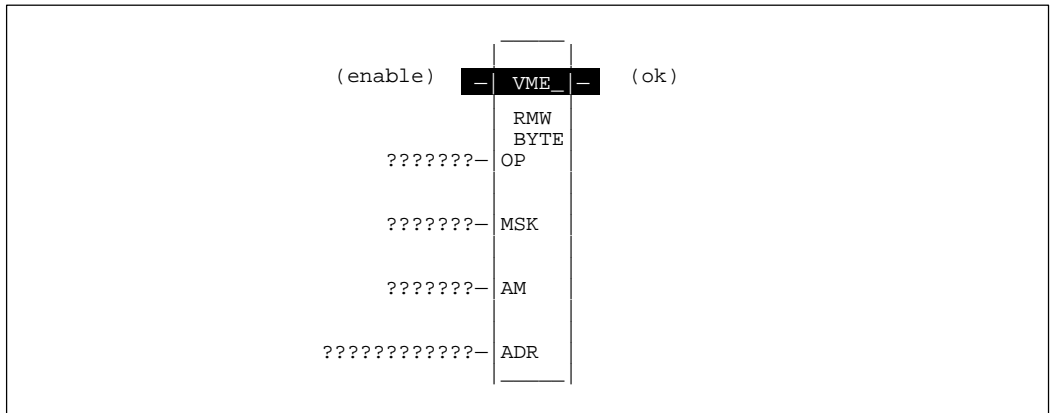

3. The function can operate on either byte or word data. The default selection is BYTE. If this should be changed to WORD, select TYPES (F10) then WORD (F2).
4. Move the cursor to the left of OP and enter the number that represents the type of operation to be performed: 0 for AND, 1 for OR. Press the Enter or Tab key.
5. Move cursor to left of MSK and enter the mask value or reference containing the mask value.
6. Move the cursor to the left of AM and enter the hexadecimal number that represents the address modifier code. To enter a hexadecimal number, enter a zero, the hexadecimal digits, and the letter H. Press the Enter or Tab key.

7. Move the cursor to the left of ADR and enter either a hexadecimal constant or the beginning (low) reference where the address of the VME module is stored.
8. If the program should check the execution of the VMERMW function, move the cursor to the upper right and enter the appropriate logic.
9. When the rung is complete, use the keypad + or Esc key to accept it.

The following memory types can be used for parameters of the VMERMW function:

**Valid Memory Types:**

Parameter	flow	%I	%Q	%M	%T	%S	%G	%R	%P	%L	%AI	%AQ	const	none
enable	•													
OP													•	
MSK	•	•	•	•	•		•	•	•	•	•	•	•	
AM	•	•	•	•	•		•	•	•	•	•	•	•	
ADR								•	•	•	•	•	•	
ok	•													•

Note: Indirect referencing is available for all register references (%R, %AI, %AQ, %P, and %L)

• = Valid data type, or place where power may flow through the function.

† = %SA, %SB, %SC only; %S cannot be used.

## VME TEST AND SET (VMETST)

The VMETST function handles semaphores located in the dual-port RAM of VME modules located in the Series 90-70 PLC rack. Typically, these are not GE Fanuc modules, but may include some GE Fanuc modules, such as the PCM. The VMETST function exchanges a boolean true (1) for the value currently at the semaphore location. If that value already was true, then the VMETST function does not acquire the semaphore. If the existing value was false, then the semaphore is set and the VMETST function has the semaphore and the use of the memory area it controls. The semaphore is cleared and ownership relinquished by using the VMEWRT function to write a 0 to the semaphore location.

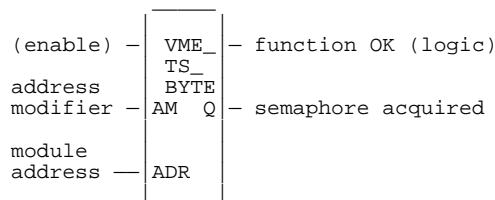

### Parameter Description

- ENABLE:** power flow input which, when energized, enables the execution of the function.
- TYPE:** function type; either BYTE or WORD to select the corresponding type of VMEbus access to be performed.
- AM:** hexadecimal value coded to specify the rack in which the module resides and the access mode of the VMEbus access to be performed. See Series 90-70 Module Address Allocation on page 3-2.
- ADR:** double word which specifies the hexadecimal address of the first word or byte to be accessed. May be a constant or the reference address of the first (low) word of two words containing the module address. The address is based on the rack and slot the module is located in. See Series 90-70 Module Address Allocation on page 3-2.
- OK:** power flow output which is energized when the function is enabled and completes successfully.
- Q:** set to true if the semaphore was acquired. Set to false if the semaphore was not available, that is, was owned by another task.

When the VMETST function receives power flow, a boolean true is exchanged with the data at the address specified by ADR using the address mode specified by AM. The VMETST function sets the Q output to true if the semaphore (false) was available and acquired. The VMETST function passes power flow to the right through its OK output whenever power is received and its operation is successful.

See Chapter 3 for a discussion on VME module addressing using address and address modifier codes.

### Example of VMETST Function

In the following example, the VMERD, VMEWRT, and VMETST functions are used to read data protected by a semaphore into the PLC.

When enabling input %M00047 is set true (elsewhere in the program), the VMETST function is executed to acquire the semaphore (semaphore VME address stored in %R00041 and %R00042). When this is successful, coil %M00047 is reset and coil %M00048 is set. When %M00048 is set, the VMERD function reads the data (20 words of data whose VME address is stored in %R00043 and %R00044; data read into %R00200 through %R00219). If the read is successful (if it is not - something is misprogrammed or broken), the VMEWRT function relinquishes the semaphore. Coil %M00048 is reset when the VMEWRT is successful. %M00049 is set to indicate to later logic that fresh data is now available.

If the semaphore was not available, VMERD and VMEWRT are not executed. The net effect is that the setting of %M00047 causes the PLC to check the semaphore each sweep until the semaphore is available. When it becomes available, the semaphore is acquired, the data is read and the semaphore is relinquished. No further action is taken until %M00047 is set again.

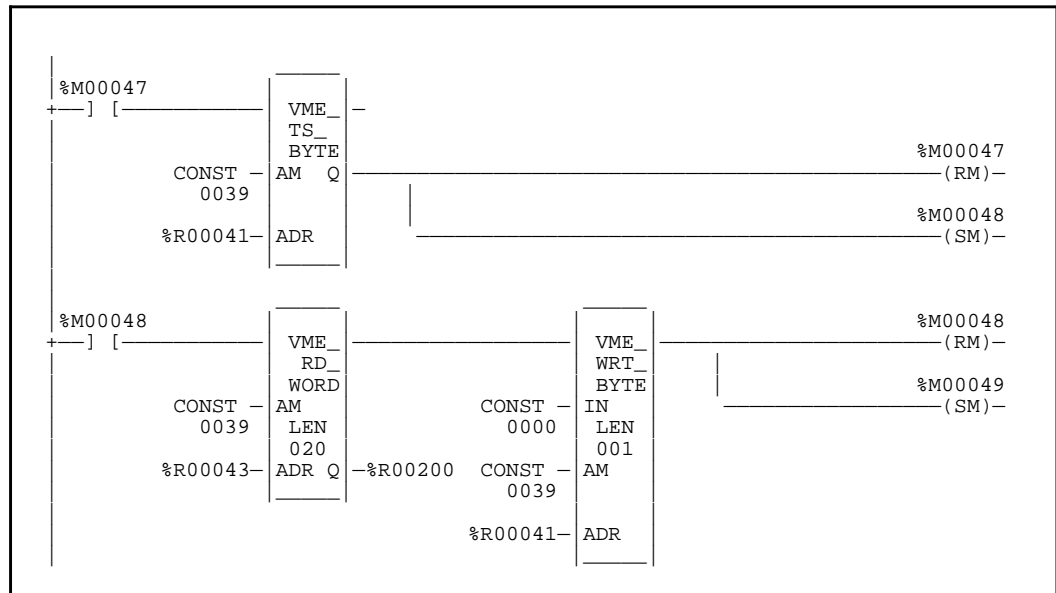

## Entering a VMETST Function

1. Enter enable input permissive logic either before or after selecting the VMETST function. Position the cursor to allow a double word function to be entered, that is, allow 2 blank cursor positions to the left of the cursor.
2. Select DATAMV (shift F6). Select MORE (F9), then VMETST (F4). The screen displays:

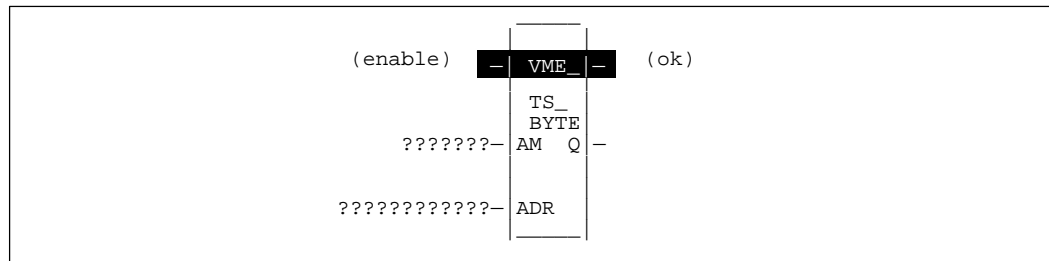

3. The function can operate on either byte or word data. The default selection is BYTE. If this should be changed to word, select TYPES (F10) then WORD (F2).
4. Move the cursor to the left of AM and enter the hexadecimal number that represents the address modifier code. To enter a hexadecimal number, enter a zero, the hexadecimal digits, and the letter H. Press the Enter or Tab key.
5. Move the cursor to the left of ADR and enter either a hexadecimal constant or the beginning (low) reference where the address of the VME module is stored.
6. Move the cursor to the right of Q and enter a coil, or logic that uses the semaphore.
7. If the program should check the execution of the VMETST function, move the cursor to the upper right and enter the appropriate logic.
8. When the rung is complete, use the keypad + or Esc key to accept it.

The following memory types can be used for parameters of the VMETST function:

### Valid Memory Types:

Parameter	flow	%I	%Q	%M	%T	%S	%G	%R	%P	%L	%AI	%AQ	const	none
enable	•													
AM	•							•	•	•	•	•	•	
ADR	•							•	•	•	•	•	•	
ok	•													•
Q	•													•

Note: Indirect referencing is available for all register references (%R, %AI, %AQ, %P, and %L)

• = Valid data type, or place where power may flow through the function.

## VME\_CFG\_RD

Use the VME\_CFG\_RD function to read the configuration for a VME module. The VME\_CFG\_RD function has five input parameters and three output parameters. When the function receives power, the data elements (N) are read from the VME bus at the location defined by rack (R), slot (S), and dual port offset (OFF). The data read is placed in output Q. The status of the operation is placed in the status word output (ST). The function has a length specification (LEN) of the maximum size of the output array.

If the function is completed successfully, ok is set ON; otherwise, it is set OFF. It is also set OFF when:

- The number of data elements (N) is greater than the length (LEN) specified.
- The rack/slot value (R and S) is out of range or is not a valid VME location.
- The most significant byte of the dual port offset (OFF) is not zero.
- The most significant byte of the dual port address plus the dual port offset is not zero.
- Read beyond the end of dual port memory.
- Specified rack/slot not configured for a Third-Party VME module in **BUS INTERFACE** mode.
- If the dual port offset is an even number, configure for the odd byte only. If the dual port offset is an odd number, configure for word or single word.

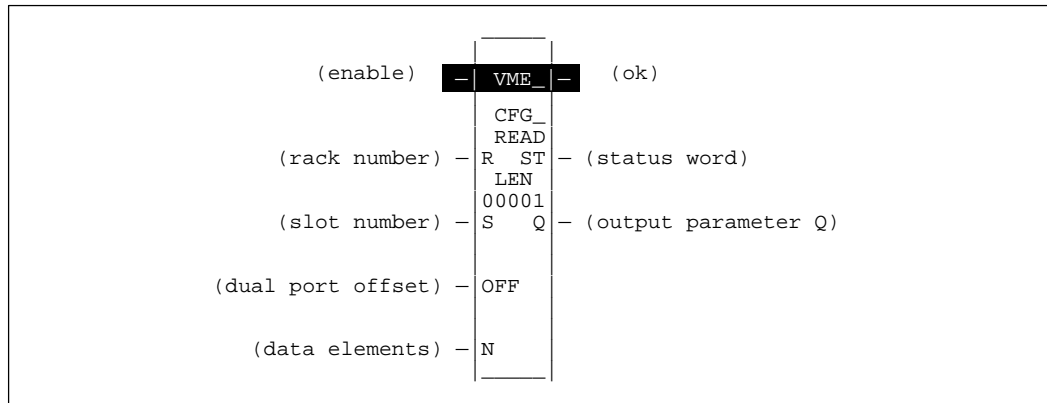

### Parameters:

Parameter	Description
enable	When the function is enabled, the data initialization is performed.
R	The rack number is specified in R.
S	The slot number is specified in S.
OFF	OFF specifies the dual port offset.
N	N contains the amount of data (data elements) to be read from the VME bus.
ok	The ok output is energized when the function is performed without error.
ST	The status word contains the status of the operation.
Q	When the function is performed, the data is read to array Q.
LEN	LEN is the length of the output array in bytes.

**Valid Memory Types:**

Parameter	flow	%I	%Q	%M	%T	%S	%G	%U	%R	%P	%L	%AI	%AQ	%UR	const	none
enable	•															
R	•	•	•	•	•	•	•		•	•	•	•	•	•	•	
S	•	•	•	•	•	•	•		•	•	•	•	•	•	•	
OFF	•					•			•	•	•	•	•	•	•	
N	•	•	•	•	•	•	•		•	•	•	•	•	•	•	
ok	•															•
ST	•	•	•	•	•	†	•		•	•	•	•	•	•		
Q	•	•	•	•	•	†	•		•	•	•	•	•	•		

- Valid reference or place where power may flow through the function
- † %SA, %SB, %SC only; %S cannot be used.

**Example:**

In the following example, when enable is ON, VME data at rack 1, slot 3 and dual port offset defined by %R00100 is read into %R00101 through %R00110 of the array %R00101 through %R00116. If an error was encountered, the status word %AQ0001 will contain an error code.

```

%I00001  VME_  -
-| |-----  CFG_  -
              READ
CONST - R  ST  -%AQ0001
00001   LEN
              00016
CONST - S  Q   -%R00101
00003
%R00100- OFF

CONST - N
00010
    
```

## VME\_CFG\_WRT

Use the VME\_CONFIG\_WRITE function to write the configuration to a VME module. The VME\_CFG\_WRT function has six input parameters and two output parameters. When the function receives power, the data elements (N) are written from the data array (IN) to the VME bus at the location defined by rack (R), slot (S), and dual port offset (OFF). The status of the operation is placed in the status word output (ST). The function has a length specification (LEN) of the maximum size of the output array.

If the function is completed successfully, ok is set ON; otherwise, it is set OFF. It is also set OFF when:

- The number of data elements (N) is greater than the length (LEN) specified.
- The rack/slot value (R and S) is out of range or is not a valid VME location.
- The most significant byte of the dual port offset (OFF) is not zero.
- The most significant byte of the dual port address plus the dual port offset is not zero.
- Read beyond the end of dual port memory.
- Specified rack/slot not configured for a Third-Party VME module in **BUS INTERFACE** mode.
- If the dual port offset is an even number, configure for the odd byte only. If the dual port offset is an odd number, configure for word or single word.

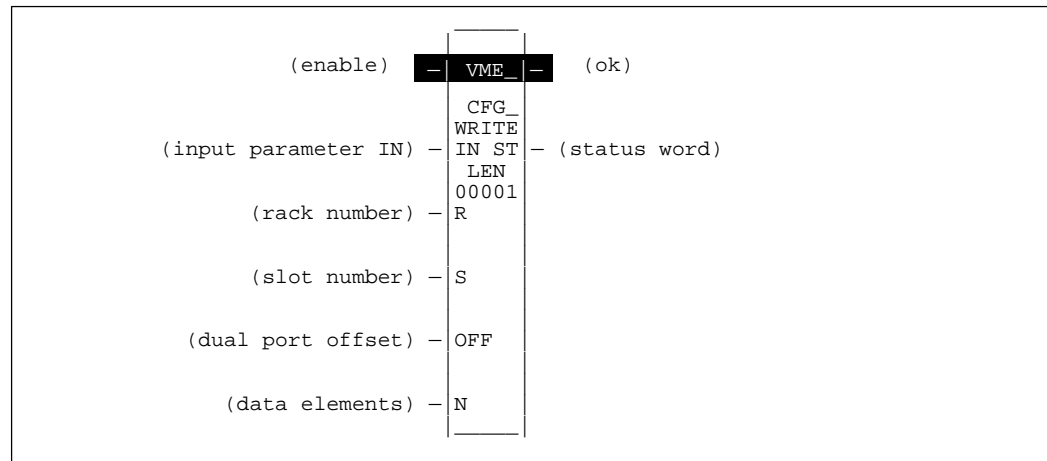



**Parameters:**

Parameter	Description
enable	When the function is enabled, the data initialization is performed.
IN	IN contains the data to be written to the VME bus at the location defined by rack (R), slot (S), and dual port offset (OFF).
R	The rack number is specified in R.
S	The slot number is specified in S.
OFF	OFF specifies the dual port offset.
N	N contains the amount of data (data elements) to be written to the VME bus.
ok	The ok output is energized when the function is performed without error.
ST	The status word contains the status of the operation.
LEN	LEN is the length of the input array in bytes.

**Valid Memory Types:**

Parameter	flow	%I	%Q	%M	%T	%S	%G	%U	%R	%P	%L	%AI	%AQ	%UR	const	none
enable	•															
IN	•	•	•	•	•	•	•		•	•	•	•	•	•		
R	•	•	•	•	•	•	•		•	•	•	•	•	•	•	
S	•	•	•	•	•	•	•		•	•	•	•	•	•	•	
OFF	•					•			•	•	•	•	•	•	•	
N	•	•	•	•	•	•	•		•	•	•	•	•	•	•	
ok	•															•
ST	•	•	•	•	•	†	•		•	•	•	•	•	•		

- Valid reference or place where power may flow through the function
- † %SA, %SB, %SC only; %S cannot be used.

**Example:**

In the following example, when enable is ON, data from %R00101 through %R00110 of the array %R00101 through %R00116 is written to the VME bus at rack 1, slot 3 and dual port offset defined by %R00100. If an error was encountered, the status word %AQ0001 will contain an error code.

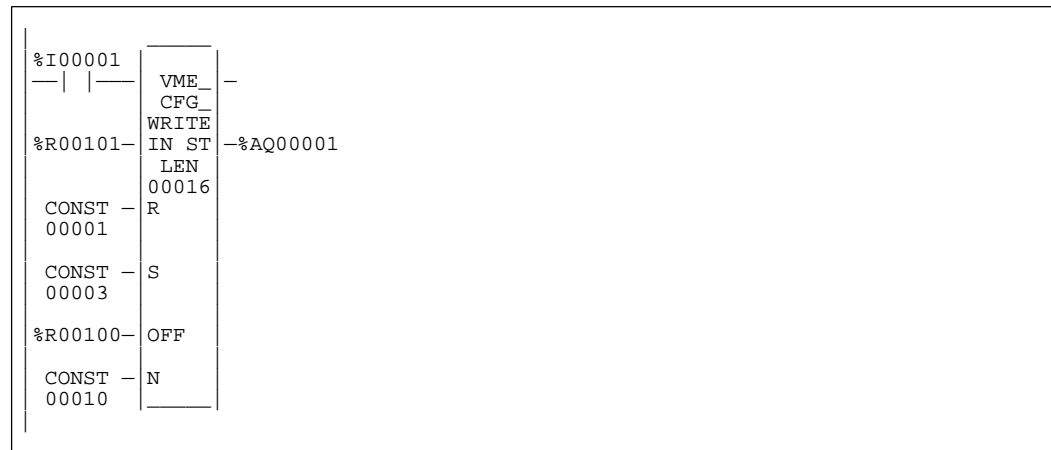

## SWAP

The SWAP function is used to swap two bytes within a word, or two words within a double word. The necessity of doing this swap was described previously in *Byte Significance Convention* at the beginning of this chapter. The SWAP can be performed over a wide range of memory by specifying a length greater than 1 for the function. If this is done, each word or double word of data within the specified length will be appropriately swapped.

The SWAP function has two inputs and two outputs:

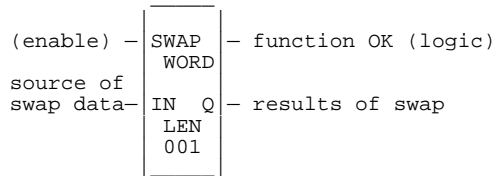

### Parameter Description

- ENABLE:** power flow input which, when energized, enables the execution of the function.
- TYPE:** function type; either BYTE or WORD to select the corresponding type of swap to be performed.
- IN:** specifies the location in PLC memory for the beginning reference for data to be swapped.
- OK:** power flow output which is energized when the function is enabled and completes successfully.
- Q:** specifies the location in PLC memory where the swapped data will be stored.

When the SWAP function receives power flow, it performs the swap operations on each word or double word of data within the specified area. The results of the swap are stored to output Q. The SWAP function passes power to the right whenever power is received.

### Example of SWAP Function

In the following example, when enabling input %I00001 goes true, two bytes located in word %I00033 through %I00048 are swapped. The result of the swap is stored in %L00007. Unless an error occurs while swapping the bytes, output coil Q00001 will be set to true.

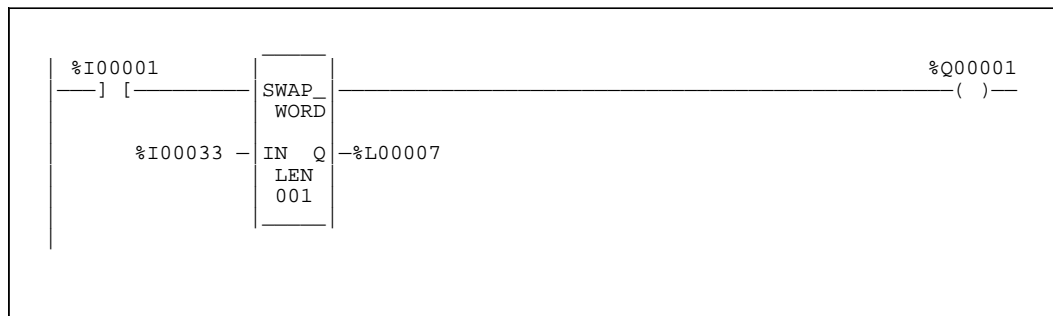

## Entering a SWAP Function

1. Enter enable input permissive logic either before or after selecting the SWAP function.
2. Select DATAMV (Shift F6). Select MORE (F9), then SWAP (F6). To change the data type, select TYPES (F10), then DWORD (F2). The screen displays:

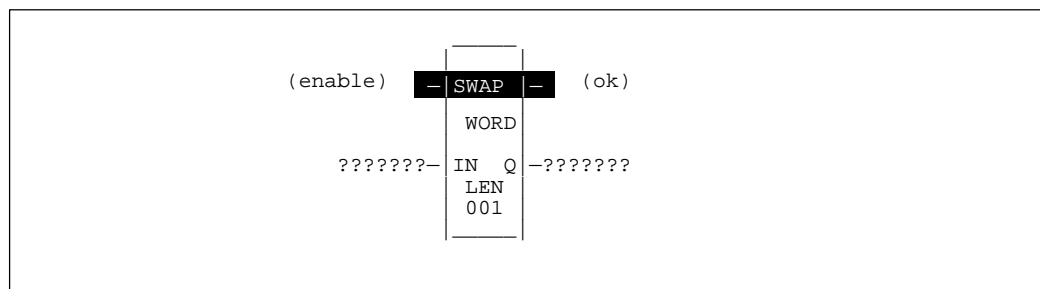

3. The function can swap either bytes or words. The default length for the swap is 1 (either 1 word or 1 double word). To specify a swap length that is different than 1, leave the cursor on the block and type in the number. Press the Enter key.
4. Move the cursor to the left of IN and enter the beginning reference for data to be swapped (the table below shows the types of inputs and outputs you can enter for this function). Press the Enter key.
5. Move the cursor to the right of Q and enter the reference where the swapped data will be stored. Press the Enter key.
6. If the program should check the execution of the SWAP function, move the cursor to the upper right and enter the appropriate logic.

The following memory types can be used for parameters of the SWAP function:

### Valid Memory Types:

Parameter	flow	%I	%Q	%M	%T	%S	%G	%R	%P	%L	%AI	%AQ	const	none
enable	•													
IN	•	o	o	o	o		o	•	•	•	•	•	•	
ok	•													•
IN	•	o	o	o	o		o	•	•	•	•	•		

Note: Indirect referencing is available for all register references (%R, %AI, %AQ, %P, and %L)

- = Valid data type, or place where power may flow through the function.
- o = Valid reference for WORD data only.

# Appendix

# A

## *Commonly Used Acronyms and Abbreviations*

---

---

Following is a list of acronyms used throughout this manual. The acronym is listed first followed by its derivation or description.

ACFAIL	AC Fail (power sequencing signal)
ADR	Address
AM	AddressModifier
ASCII	American National Standard Code for InformationInterchange
BCD	Binary Coded Decimal
BCLEAR	Bus Clear signal
BRM	Bus Receiver Module
BRx	Bus Request line (x is the Bus Request line number)
BTM	Bus TransmitterModule
CPU	Central ProcessingUnit
H	Hexadecimal
IRQx	Interrupt Request (x is the Interrupt Request number)
LSB	Least Significant Bit
PLC	ProgrammableLogicController
RAM	RandomAccessMemory
SYSFAIL	System Fail (power sequencing signal)
SYSRESET	System Reset (power sequencing signal)
VITA	VME International TradeAssociation
VME	VERSA Module Europe
VME-I	IndustrializedVMEbus
VMERD	VME Read function
VMERMW	VME Read/Modify/Write function
VMETST	VME Test and Set function
VMEWRT	VME Write function

This page intentionally left blank.

# Appendix B

## *Why Do Restrictions Exist?*

---

---

The body of this manual describes a number of restrictions and recommendations for adding 3rd party VME modules to the Series 90-70 PLC. This appendix describes the reasons for certain of these restrictions. This appendix is intended for use by those of you who want more information than is provided in the body of this manual.

### **Interrupts and a 3rd Party Interrupt Handler**

If it is necessary to use interrupts 1 through 4, a 3rd party interrupt handler is required. The 3rd party handler must be configured to handle interrupt requests IRQ1 through IRQ4 only.

In the Series 90-70 PLC system IRQ1 through IRQ4 are used for slot identification. Jumper locations are provided to disable slot identification and connect IRQ1 through IRQ4 to the backplane. Therefore, when using 3rd party interrupt handlers, it is necessary to install jumpers on the backplane at the slots that contain the interrupt handler and 3rd party boards that will request interrupts.

A foreign interrupt handler becomes a bus master when servicing interrupts, therefore all foreign bus master restrictions apply.

### **AM Codes and Expansion Racks**

The Series 90-70 VME bus is extended to expansion racks through the Bus Transmitter and Bus Receiver modules. During short access the Series 90-70 user defined AM codes, 10H through 1FH, are used by the Bus Transmitter Module to determine if the short access is directed towards the main or expansion racks. During a short access the Bus Receiver Module uses the Series 90-70 user defined AM code to determine if its rack has been selected.

During standard access the Bus Transmitter Module and Bus Receiver Modules use the address to determine which rack the modules reside in. When a Bus Transmitter Module receives an address allocated to an expansion rack it drives the VME bus in the main rack and transmits the address to the Bus Receiver Modules in the system. Any Bus Receiver Module present will then respond to the VME access if the address is allocated to the rack it resides in.

### **Restrictions for AM Code 29H**

During short access the Bus Receiver Module waits to receive the Series 90-70 defined AM code for its rack. The Bus Receiver Module then converts the Series 90-70 defined

AM code to the corresponding short access AM code. After converting an AM code, the Bus Receiver module takes control of the VME bus transferring control signals and data to and from its rack. For example, assume that you have programmed AM code 18H and address 4000H in a VME byte write function block. The Bus Transmitter Module will take control of the VME bus in the main rack and transmit AM code 18H and address 4000H. The Bus Receiver Module present in rack 7 will convert AM code 18H to 29H and transmit it, the control address, and data to the local bus in rack 7.

## Restrictions for AM Code 39H

The user defined address 100000H through 7FFFFFFH for AM code 39H is restricted to rack 0. This is due to the fact that the Bus Transmitter Module will not pass rack 0 allocated addresses to extended racks. If a Bus Transmitter Module is not present address 100000H through 0FFFFFFH is unused address space and can be allocated to 3rd party modules.

When a Bus Transmitter Module is present unused address space allocated to expansion racks cannot be assigned to 3rd party modules in the main rack. This restriction is due to the fact that the Bus Transmitter Module will always drive the backplane when an address allocated to an expansion rack is used. This occurs with or without the expansion rack present.

Unused address space in expansion racks must only be assigned to 3rd party modules located in that rack. This restriction is due to the Bus Receiver Module. The Bus Receiver Module will only respond to addresses allocated to the rack it resides in.

## Restrictions for AM Codes 0DH and 09H

It is possible to use extended addressing (32 bit address) in the main rack only. To use extended addressing you must pull the upper address bits A24 through A31, located on the P2 connector, to a known state. You can then program a VME access function block with the correct extended AM code and address. Extended access will not interfere with Series 90-70 modules.

## Restrictions for AM Code 2DH

Immediately after a power cycle or after Logicmaster 90 has downloaded a new configuration to the CPU, the Series 90-70 CPU will check for the presence of GE Fanuc modules in each available rack and slot. Using AM code 29H, the CPU will attempt to read the module "VME ID" bytes from each of the short address ranges listed in the table on page 3-2. If any data can be read successfully, indicating the presence of a module, then the CPU will set a diagnostic bit at offset address 1 using AM code 2DH.

When using a non-GE Fanuc module, the effect of such a write to the board should be carefully considered. If this could cause a problem, it is recommended that the module addressing be configured to respond in the "user defined" range as listed. Another alternative might be to disable the board response to AM code 2DH.

# Appendix C

## Configuration Examples

---

---

This appendix contains three examples of configuring 3rd party VME modules. These configuration examples include:

1. Two examples of a single slot board in the main (CPU) rack;
2. A 3rd party VME module in an expansion rack.

### Example 1 - Single Slot Module Located in the Main Rack

The following assumptions are made:

- A. The module can be configured as a D16/A16 or D16/A24.
- B. The address and AM code are configurable.

The module will be configured for two different Series 90-70 configurations.

Table C-1. Example 1 - Series 90-70 Configuration 1

Slot	Module
1	IC697CPU731- CPU
2	IC697PCM711 - PCM
3	IC697MDL650 - 32 point, 24VDC Input
4	IC697MDL740 - 32 point 24/48VDC Output
5	IC697BEM713 - Bus TransmitterModule
6	3rd Party VME Module

Table C-2. Example 1 - Series 90-70 Configuration 2

Slot	Module
1	IC697CPU771- CPU
2	IC697PCM711 - PCM
3	IC697MDL650 - 32 point, 24VDC Input
4	IC697MDL740 - 32 point 24/48VDC Output
5	3rd Party VME Module



### Example 1 - Configuration 1

For Configuration 1 the 3rd party module must be located in slot 6. The following address ranges are available:

**Table C-3. Example 1 - Configuration 1 Available Address Range**

AM Code	Address Range
29H	3000H- FFFFH
2DH	3000H- FFFFH
39H	080000H- 7FFFFFFH
3DH	000000H- 7FFFFFFH

The best address choice is AM code 3DH. With this configuration, the module will be out of the Series 90-70 address range. This allows for Series 90-70 module expansion without having to reconfigure the 3rd party module.

### Example 1 - Configuration 2

For configuration 2, the 3rd party module must be located in slot 5. Without the Bus Transmitter Module the following address ranges are available:

**Table C-4. Example 1 - Configuration 2 Available Address Range**

AM Code	Address Range
29H	2800H- FFFFH
2DH	2800H- FFFFH
39H	080000H- 7FFFFFFH
3DH	000000H- 7FFFFFFH

The best address choice is AM code 3DH. As with the previous example, this will allow for Series 90-70 module expansion. If a Bus Transmitter Module will never be present in the system, then AM code 39H with address range 100000H through FFFFFFFH will also allow for Series 90-70 module expansion within the main rack.

## Example 2 - Single Slot Module Located in an Expansion Rack

In this example, a 3rd party module will be located in an expansion rack. It is assumed that the module's AM code and address range are configurable. The module will be located in expansion rack 4 which has the following configuration:

**Table C-5. Example 2 - Series 90-70 Expansion Rack Configuration**

Slot	Module
1	IC697BEM711- Bus Receiver Module
2	IC697MDL650 - 32 point, 24VDC Input
3	3rd party VME module

With this configuration the available address range is as shown in the following table. As stated previously, AM code 3DH is not available in expansion racks.

**Table C-6. Example 2 - Available Address Range**

AM Code	Address Range
29H	1800H - FFFFH
2DH	1800H - FFFFH
39H	B20000H - BFFFFFFH

The best choice for this configuration is to use either AM code 29H or 2DH and address range 5000H through FFFFH. This will allow for expansion within this rack without having to reconfigure the 3rd party VME module. When using a short access to address this module the AM code programmed must be 1BH for configured AM code 29H and 13H for configured AM code 2DH.

# Appendix D

## Quick Compatibility Checklist

---

---

This appendix provides a checklist to be used as a quick reference to help select Series 90-70 PLC compatible 3rd party VME modules. There may also be other factors which determine compatibility. Refer to the text in this manual for more detailed information.

- The module must comply with VMEbus Specification Revision C.1.
- Series 90-70 CPUs that allow operation with foreign masters were available beginning with the first quarter of 1992. Catalog numbers of these CPUs are: IC697CPU731P, IC697CPU732D, IC697CPU771M, and IC697CPU772D (or later revision of each model), and all newer CPU models. Previous revisions may not work properly when used with foreign masters.
- The Series 90-70 rack accommodates 6U modules; 3U modules require the use of adapter hardware or a 6U faceplate to support the smaller 3U module.
- The standard Series 90-70 rack has only a J1 backplane. To use modules with both P1 and P2 connectors you must add a J2 backplane to the Series 90-70 rack and provide the required power connections. No Series 90-70 module uses the J2 backplane.
- The standard Series 90-70 racks (catalog numbers IC697CHS750/790/791) provide card guides for every other VME slot. Multiple slot modules, or modules which have daughter boards can not plug into these racks without modification. The VME Integrator racks (IC697CHS782/783) provide card guides and connectors for every VME slot (17 slots).
- The module must be A24 (standard) or A16 (short) address compatible. Although the Series 90-70 PLC system does not support A32 (extended) bit addressing, such modules may be used if the upper 8 address bits (A24 through A31) are strapped to a fixed value.
- The module must be compatible with D16 (16 data bits) and D8 (8 data bits) data transfers. The Series 90-70 PLC system does not support D32 (32 data bits) data transfers. 16 bit data transfers are preferred.
- The module must respond to one or any combination of the following address modifier (AM) codes:
  - 2DH, 29H Short Access
  - 39H, 3DH Standard Access
- Modules responding to AM code 3DH must reside in the main rack.
- The module must not respond to Series 90-70 defined AM codes 10H through 1FH.
- Modules requiring " 12VDC must reside in a rack powered by the GE Fanuc 100W AC/DC, 90W 24 VDC or 90W 48 VDC power supply.

- Per connector current requirements for any VME module must not exceed 4.5A at 5 VDC and 1.5A at " 12 VDC at 25°C (77°F). The GE Fanuc power supplies provide:
  - 55W AC/DC power supply: 11 amps of 5 volt DC power;
  - 90W 24 VDC power supply: 18 amps of 5 volt DC power, 1.5 amps of +12 volt DC power, and 1 amp of -12 volt DC power;
  - 90W 48 VDC power supply: 18 amps of 5 volt DC power, 1.5 amps of +12 volt DC power, and 1 amp of -12 volt DC power;
  - 100W AC/DC power supply: 20 amps of 5 volt DC power, 2 amps of +12 volt DC power, and 1 amp of -12 volt DC power.
- Multi-board sets which have 0.8" centers will not fit in the standard Series 90-70 rack since the rack backplane connectors and card guides are on 1.6" centers. To use these these types of modules requires the VME Integrator rack, which has connectors and card guides on 0.8" centers.
- Cooling fans may be required for non GE Fanuc modules to meet the 0 to 60°C (32 to 140°F) operating temperature range of the Series 90-70 PLC. For applications requiring additional cooling, an optional rack fan assembly (IC697ACC721) is available.
- The range of addresses to which the module responds must be configurable to prevent overlap with those used by any Series 90-70 modules present in the system.
- All Bus Arb functions must be disabled at power-up.
- Modules must not assert the signals ACFAIL and SYSRESET. If they do, the system will not operate properly. If the module asserts SYSFAIL, it must do so only at power-up, and must drive SYSFAIL for no longer than one second.
- Masters must not use Address Only (ADO) cycles.
- The module must be able to recover from SYSFAIL which is asserted by the Series 90-70 CPU during power-up, and during I/O configuration.
- Modules must not generate block transfer cycles.
- VITA categorizes modules by address width, data width, data transfer type, and master/slave. Modules which are most likely to be integrated into the Series 90-70 PLC System are characterized by one or more of the following acronyms (the acronyms are explained in both the VITA catalog and the VMEbus Specification).

A16	D8
A24	D16
A32	D32
SAD016	SD8(O)
SAD024	SRMW8(O)
SD8	SD16
SBLT8	SBLT16
SRMW8	SRMW16
SALL8	SALL16

Appendix  
*E*

## *VMEbus International Trade Association*

---

---

The VMEbus International Association (VITA) publishes three documents which may be helpful to users of VME-based products. These documents are:

The *VMEbus Compatible Products Directory*, which contains listings of VMEbus compatible products.

The *VMEbus Specifications*, which describes the VMEbus.

The *VMEbus Handbook*, which is a user's guide to VMEbus board design.

The Introduction to the *VMEbus Compatible Products Directory* describes VITA as:

The VMEbus International Trade Association is an incorporated non-profit organization of vendors and users having common market interests. The functions performed by VITA are both technical and promotional. They are aimed at increasing the total market size, providing vendors greater market exposure and affording users more timely technical and product availability information. VITA also provides users with a channel of communication. VITA operates through its various committees and has offices in the USA and Europe. For additional information, please contact:

VITA  
10229N. Scottsdale Road  
Suite B  
Scottsdale, Arizona 85253  
U.S.A.  
(602)951-8866

VITA - Europe  
P.O. Box 192  
NL - 5300 AD Zaltbommel  
The Netherlands  
31.4180.14661

This page intentionally left blank.

# Appendix *F*

## VME Integrator Racks

---

---

This appendix describes the Series 90-70 VME Integrator Racks available from GE Fanuc. Two versions of VME Integrator racks are available. Catalog numbers for the VME Integrator racks are as follows:

**17-Slot, Rear Mount - IC697CHS782**

**17-Slot, Front Mount - IC697CHS783**

### Features

- Accepts 3rd Party VME modules which require 0.8 inch spacing.
- Accepts all Series 90™-70 PLC module types.
- Rear mount rack mounts in a 10 inch (254 mm) deep enclosure.
- Front mount rack mounts in a standard 19 inch (483 mm) rack.
- Accepts plug-in AC/DC and DC GE Fanuc power supplies, or can use external supply (Power Supply Adaptor module required).
- Provision for two rack operation from single power supply.
- Provision for power supply for high-current configurations.
- Optional accessory kit available for adding J2 backplane.
- Optional fan assembly (for high-power 3rd Party modules and Series 90-70 CPU modules that require forced air cooling).

### Functions

The available VME Integrator Racks for the Series 90-70 Programmable Logic Controller can be used for all Series 90-70 CPU and I/O configurations (except redundancy applications), and 3rd party VME modules. This rack has a 17-slot backplane and is designed to provide easy integration of 3rd party VME modules into a Series 90-70 PLC system. ***Integration of 3rd Party VME modules must be in accordance with guidelines described in this manual, the User's Guide to Integration of 3rd Party VME Modules, GFK-0448B, or later.***

Backplane connectors are spaced on 0.8 inch centers to accommodate 3rd party VME modules. Series 90-70 modules each use two of these slots. *Standard Series 90-70 racks have slots spaced on 1.6 inch centers for Series 90-70 modules.* VME modules that require 0.8 inch spacing for installation will not fit in standard Series 90-70 racks (IC697CHS750/790/791).

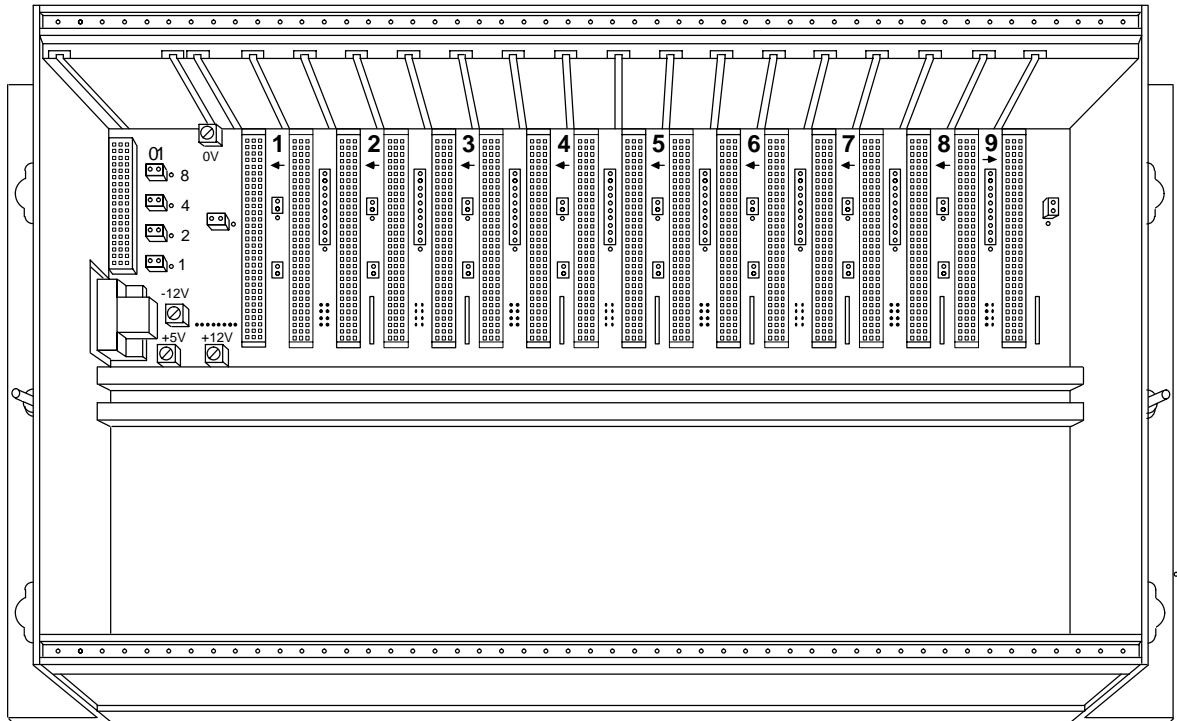

**Figure F-1. VME Integrator Rack**

Each rack configuration will accept one power supply in the leftmost module position, and either

1. 17 3rd Party VME modules
2. 9 Series 90-70 modules, or
3. a combination of Series 90-70 and 3rd Party VME modules.

**Note**

The power supply capacity may limit the maximum number of modules in a rack. *No more than three VME modules can be used in a rack with Series 90-70 modules.*

The flexibility of this rack to allow both 3rd party VME and Series 90-70 modules is accomplished through the use of jumpers on the backplane to configure slots. The VME Integrator rack is factory configured to accept standard Series 90-70 modules. Integration of 3rd party VME modules is done by moving these jumpers to different positions. The exact jumper configuration depends on the requirements of each 3rd Party VME module.

Two racks can be interconnected to share a single power supply for applications having extended I/O requirements. A Power Supply Extension Cable kit (IC697CBL700) is available for such applications. There are also four *powercube* screw connections (+5V, +12V, -12V, 0V) on the backplane for use with a Series 90-70 power supply when used to supply power to an optional P2 backplane. *These connections are not intended for direct connection to a 3rd Party power supply.*

Each rack provides slot sensing for rack-type I/O modules designed for the Series 90-70 PLC. No jumpers or DIP switches on the I/O modules are required for module addressing.

Overall rack dimensions are:  
*height = 11.15 inches (283mm)*  
*width = 19 inches (483mm)*  
*depth\* = 7.25 inches (184mm).*

\* Depth is 8.25 inches (209mm) with spacers in VME option kit installed.

Slots are 0.8 inch wide except the power supply slot which is 2.4 inches wide.



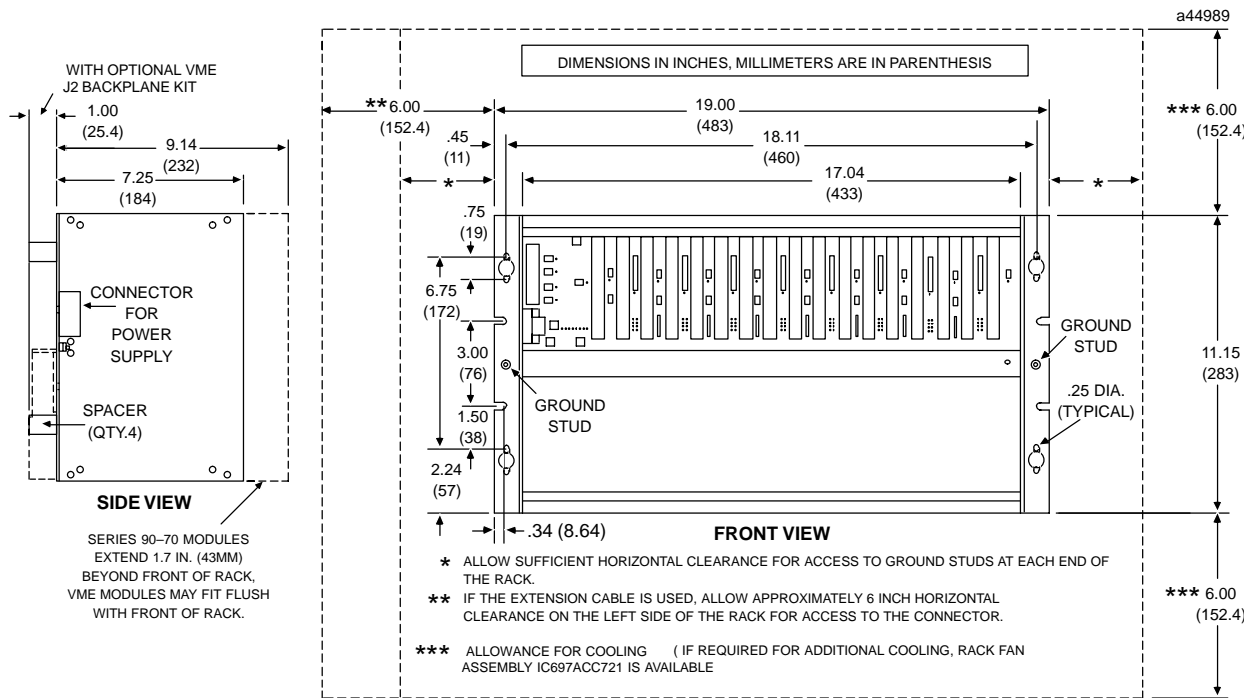

**Figure F-2. VME Integrator Rack Dimensions for Rear (Panel) Mount Installation**

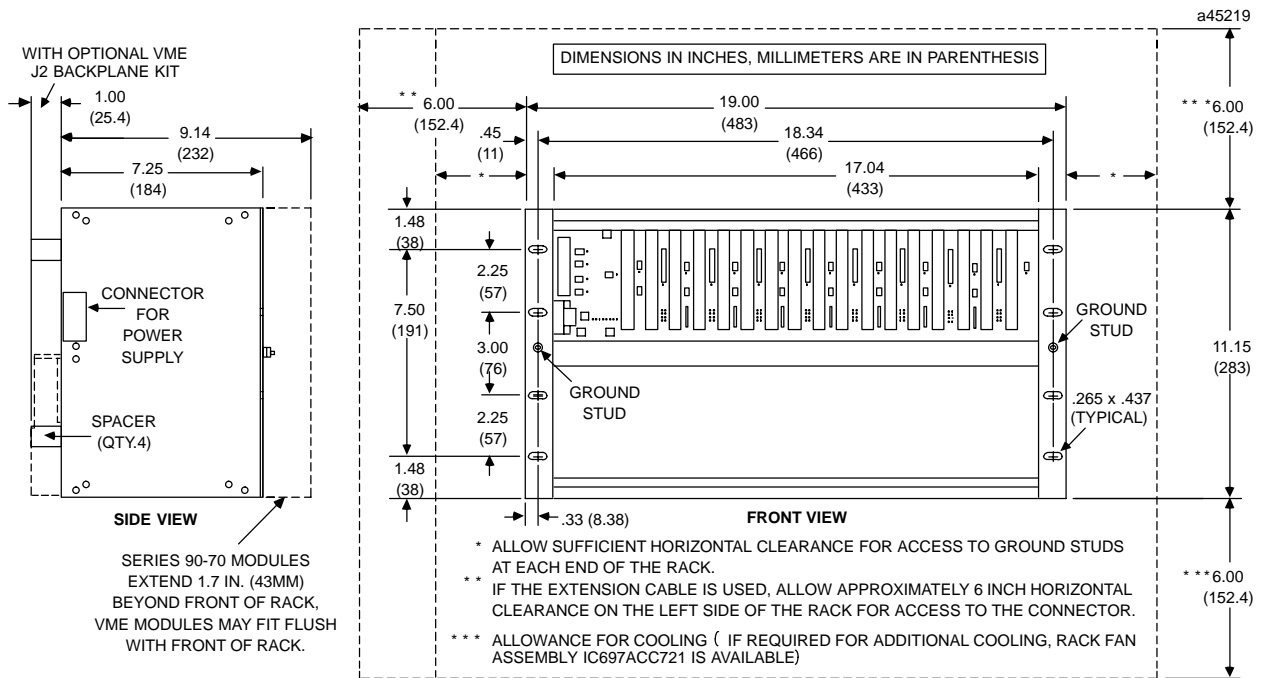

**Figure F-3. VME Integrator Rack Dimensions for Front (Rack) Mount Installation**

## Rack Mounting

Racks are available for either rear (panel) or front (rack) mounting. Rack dimensions and installation information for each type or rack is shown in Figures F-2 and F-3 on the previous page. The rack must be mounted in the orientation shown in the figures. Sufficient space must be left around the rack as shown to allow air flow for module cooling. A Rack Fan Assembly is available for installations requiring forced air cooling.

The mounting requirements (either front or rear mount) must be determined according to the application and the proper rack ordered. Refer to the illustrations on the previous page for mounting dimensions of these racks. Mounting flanges are an integral part of rack side panels and are installed at the factory.

## I/O Connections

The VME Integrator racks accommodate two module types.

First, they accommodate rack-type Series 90-70 high-density I/O modules, which use a detachable field wiring terminal board. Each I/O module will accept up to forty AWG #14 (2.1 mm<sup>2</sup>) wires. The wire bundle is routed out the bottom of the terminal board cavity where a cleat is provided for a tie wrap to secure the bundle to the terminal board housing.

Second, they accommodate VME modules which may have varying methods of connecting to field devices.

## Configuring a VME Integrator Rack

A series of jumper positions are located on the backplane near each slot. These jumpers provide for flexibility in the types of modules to be installed, either VME modules in single slots (0.8 inch spacing between centers) or Series 90-70 modules, which require two slots (1.6 inch spacing between centers).

Table F-1 shows the relationship of the slot numbers to the jumper numbers. Configurable functions and signals are:

- *select rack ID* for multiple rack systems (Series 90-70 feature)
- configure *SYSFAIL* signal to be enabled or disabled (per slot)
- *LWORD* signal in slot 1 configurable to be inactive
- configure *IRQ1/ - IRQ4/* signals for VME slots 12PL to 19PL
- configure *Bus Grant* signals for VME slots 12PL to 19PL

The following figure is an example of the location of these jumpers on the backplane. The jumpers shown are referenced in the text following the figure.

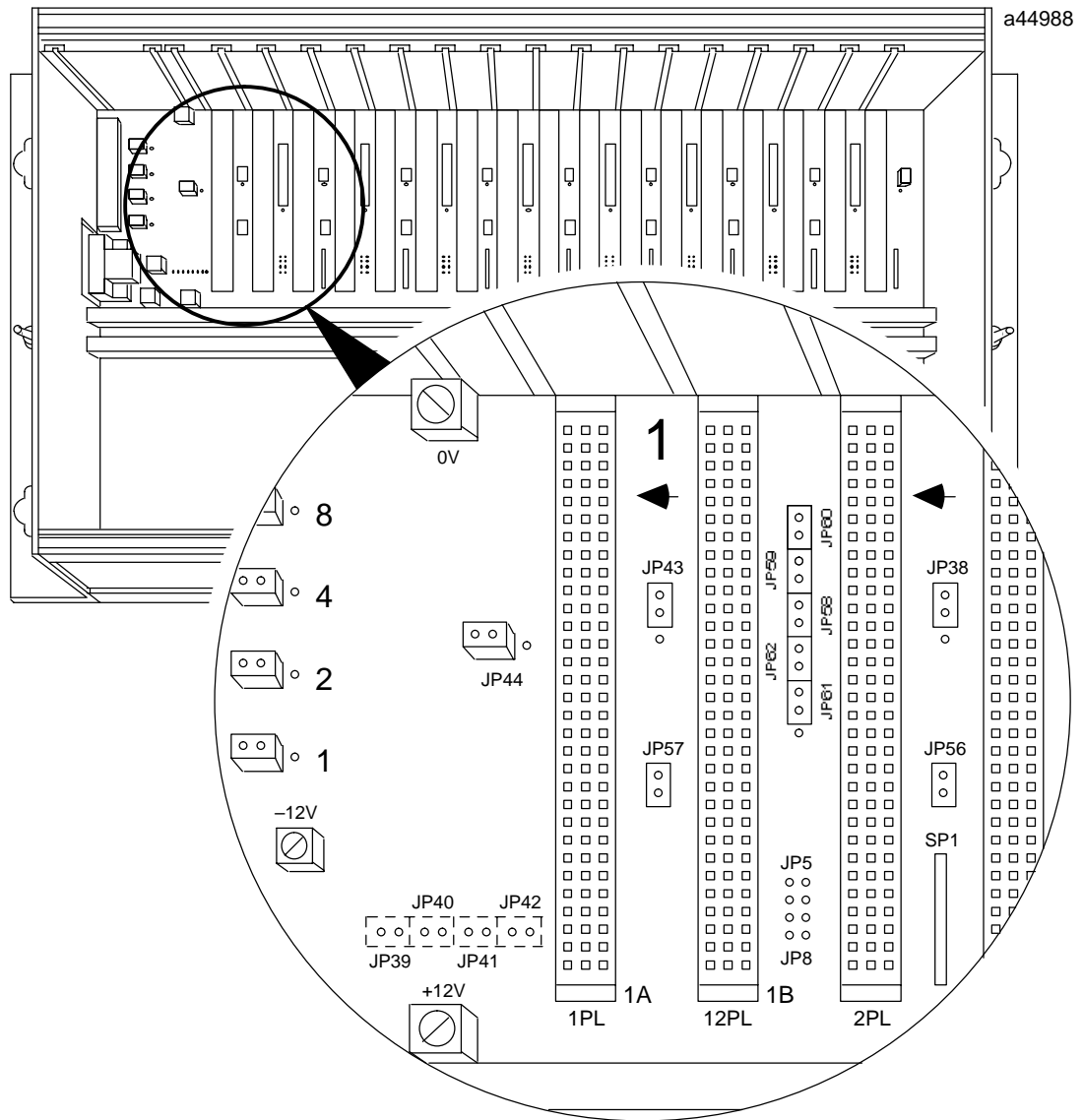

Figure F-4. Example of Jumper Locations on Backplane

## Default Jumper Configurations

The following table describes the jumper configuration for each of the configurable VME rack signals. The default jumper configuration for each of these signals is shown following the table. Table F-1 on the next page lists all of the jumper numbers and their associated slots.

Signal Name or Function	See	Applicable Jumpers	Description
Rack ID Select	-	JP1 to JP4	Selects rack ID number 0 -7, see text for settings ( <i>default rack ID = 0</i> )
SYSFAIL/	<b>A</b>	See Table 1 for jumper numbers.	Enabled or disabled for each slot ( <i>default = enabled</i> ).
LWORD/	<b>B</b>	JP44	Slot 1 only, set to active or inactive ( <i>default=inactive</i> ).
IRQ1/ to IRQ4/ (Interrupt lines)	<b>C</b>	See Table 1 for jumper numbers	Select for Series 90-70 module slots 1PL to 9PL. If VME module in slot uses these signals, install jumpers ( <i>default = no jumpers</i> ).
Bus Grant 0 - 3/ and IACK/	<b>D</b>	See Table 1 for jumper numbers	If VME modules are installed that pass daisy chain signals, jumpers must be removed in VME slots 12PL to 19P ( <i>default = jumpers</i> ).

A configuration selection consists of a jumper plug which is placed over two adjacent pins. In some cases (such as LWORD jumper), this pin is placed over 2 of 3 in-line pins; other selections require the jumper plugs to be present or not be present. Factory default jumper positions are shown below with shaded areas representing a jumper that is present. **The configuration example shown below is for slot 12PL. The physical arrangement for the other connectors is the same, only the jumper numbers (JPxx) are different.**

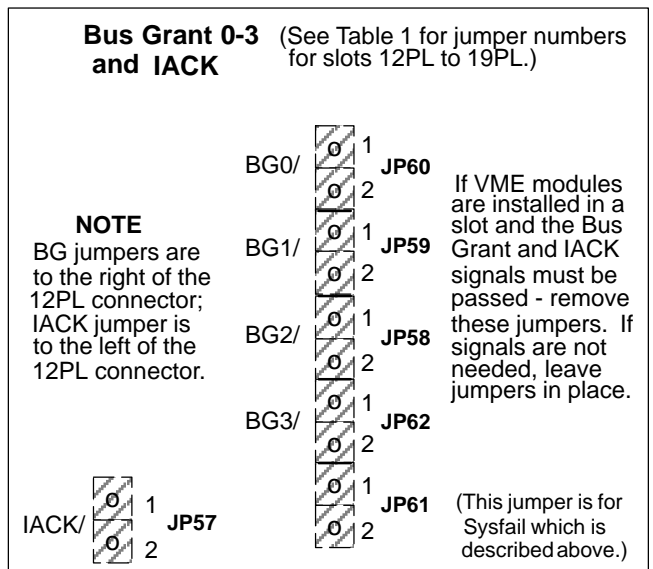
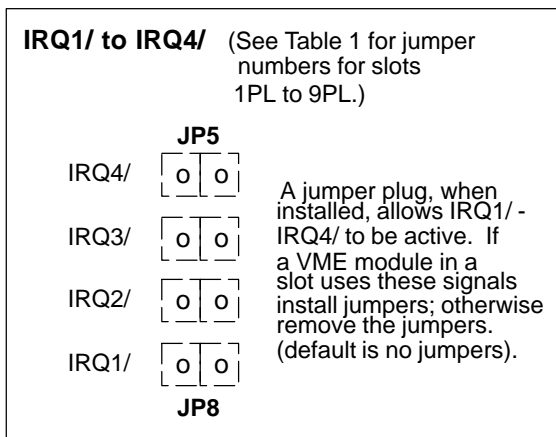
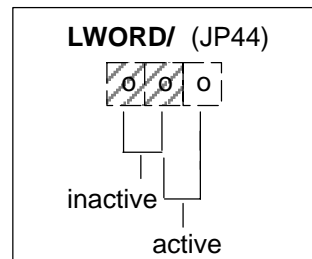
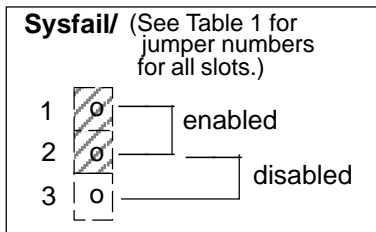

\* shaded boxes represent default positions

The following table is a list of the slots, and jumpers associated with each slot. Multiple jumpers listed in a column under a signal are shown in the same nu-

merical order as they appear on the back-plane (that is, left to right or top to bottom).

**Table F-1. VME Integrator Rack Jumper Location and Function**

Slot Number	Bus Grant 0→3 Jumpers	IACK Jumper	Sysfail Jumper	IRQ1/ to IRQ4/ Jumper
1VME-12PL(1B)	JP60, 59, 58, 62	JP57	JP61	-
2VME-13PL(2B)	JP53, 54, 55, 51	JP56	JP52	-
3VME-14PL(3B)	JP66, 65, 64, 68	JP63	JP67	-
4VME-15PL(4B)	JP72, 71, 70, 74	JP69	JP73	-
5VME-16PL(5B)	JP78, 77, 76, 80	JP75	JP79	-
6VME-17PL(6B)	JP84, 83, 82, 86	JP81	JP85	-
7VME-18PL(7B)	JP90, 89, 88, 92	JP87	JP91	-
8VME-19PL(8B)	JP96, 95, 94, 98	JP93	JP97	-
1GEF-1PL(1A)	-	-	JP43	JP39, 40, 41, 42
2GEF-2PL(2A)	-	-	JP38	JP5, 6, 7, 8
3GEF-3PL(3A)	-	-	JP99	JP9, 10, 11, 12
4GEF-4PL(4A)	-	-	JP45	JP13, 14, 15, 16
5GEF-5PL(5A)	-	-	JP46	JP17, 18, 19, 20
6GEF-6PL(6A)	-	-	JP47	JP21, 22, 23, 24
7GEF-7PL(7A)	-	-	JP48	JP25, 26, 27, 28
8GEF-8PL(8A)	-	-	JP49	JP29, 30, 31, 32
9GEF-9PL(9A)	-	-	JP50	JP33, 34, 35, 36

There are three basic configurations of modules that can be accommodated by the VME Integrator rack:

1. Standard (Series 90-70 modules only)
2. Series 90-70 controller, and Series 90-70 modules and/or 3rd party VME modules, or
3. 3rd party VME modules only. Refer to Table F-1 for jumper numbers and their functions.

**(1) Standard Configuration**

This configuration consists of a Series 90-70 CPU or Bus Receiver in slot 1PL and Series 90-70 modules in the remaining applicable slots (2PL to 9PL).

**Note**

Do not install Series 90-70 modules in VME slots 12PL to 19PL.

**Standard Configuration Jumper Positions**

Refer to Figure F-4 which is an example of jumper positions and numbers per slot.

- JP1 through JP4 (rack ID jumpers) jumpered to the proper position for Rack ID, where applicable.
- JP43 remains in its default position (as shipped from factory). This allows the SYSFAIL signal to be activated by the Series 90-70 CPU.
- JP44 remains in its default position. This jumpers the LWORD signal in slot 1 to be inactive allowing only 16-bit wide data transfers.
- All other jumpers remain in their factory set default positions.

**(2) Series 90-70/VME Configuration**

This configuration consists of a Series 90-70 CPU or Bus Receiver module in slot 1PL and a combination of Series 90-70 modules and 3rd party VME modules in the remaining slots. Series 90-70 modules can

be placed in slots 2PL to 9PL only. 3rd party VME modules can use the VME slots 12PL to 19PL and slots 2PL to 9PL. Note that all slots have a jumper that allows you to disable the SYSFAIL/ signal to that slot by removing the appropriate jumper.

### Note

Integration of 3rd Party VME modules must be in accordance with guidelines described in this manual (*User's Guide to Integration of 3rd Party VME Modules*, GFK-0448B, or later).

#### Series 90-70/VME Jumper Positions

- JP 1 through JP4 (rack ID jumpers) jumpered to the proper position for Rack ID.
- JP43 remains in its default position (as shipped from factory). This allows the SYSFAIL signal to be activated by the Series 90-70 CPU (SYSFAIL required by Series 90-70 I/O modules).
- JP44 remains in its default position. This jumper the LWORD signal in slot 1 to inactive (for GE Fanuc modules) allowing only 16-bit wide data transfers.
- VME modules can be installed in either the Series 90-70 module slots (2PL to 9PL) or in the VME slots (12PL to 19PL).
- If VME modules are installed in the Series 90-70 module slots (2PL to 9PL) and they use the IRQ1/ - IRQ4/ signals, then you must install the four jumpers in positions that are located to the immediate left of the Series 90-70 slots in use.
- If the VME modules are installed in VME slots (12PL to 19PL), and the board must pass the Bus Grant and IACK signals, you must remove five jumpers for each slot being used. *Leave these jumpers in if the board does*

*not need to pass the Bus Grant and IACK signals on a daisy chain.* These jumpers are the top four to the immediate right of the slot being used and the lower (of two jumpers) to the immediate left of the slot being used.

### (3) VME Configuration

This configuration consists of a 3rd party Controller in slot 1PL and 3rd party VME modules in the remaining slots (2PL to 9PL and 12PL to 19PL). Note that each slot has a jumper that allows the SYSFAIL/signal to be disabled to that slot since all VME modules may not require access to that signal.

#### VME Jumper Positions

- To configure slot 1 for a 3rd party controller, five jumpers must be removed. There are four jumpers behind the power supply (JP1 to JP4) that must be moved to positions JP39 to JP42. Jumper JP44 must be moved from its default position to the right.
- If VME modules are installed in the Series 90-70 module slots (2PL to 9PL) and they use the IRQ1/ - IRQ4/ signals, then you must install four jumpers in the positions that are located to the immediate left of the Series 90-70 slots in use.
- If the VME modules are installed in VME slots (12PL to 19PL), and the board must pass the Bus Grant and IACK signals, you must remove five jumpers for each slot being used. *Leave these jumpers in if the board does not need to pass the Bus Grant and IACK signals on a daisy chain.* These jumpers are the top four to the immediate right of the slot being used and the lower (of two jumpers) to the immediate left of the slot being used.

## Power Supply Extension Cable

For many applications, one power supply is sufficient for the power requirements of two racks. This two-rack operation from a single power supply can be implemented if only 5 volt power of 5.2 amperes or less is required in the second rack.

A 3-foot Power Supply Extension cable available from GE Fanuc (see the Ordering Information at end of this appendix) provides the necessary interconnection. In addition to +5 volt power, the extension cable includes power sequencing signals necessary for proper system operation.

The Power Supply Extension cable attaches to a 9-pin D-type connector located on the backplane. Access to the connector is through a hole in the left side of the rack as shown in the outline drawing (Figure F-1). Adequate clearance (approximately 6 inches) must be provided on the left side of the rack for access to the connector.

This connector can also be used to provide power to a user installed 3rd party J2 backplane. An option kit (IC697ACC715) is available for installing a J2 backplane. Maximum power that can be supplied to the J2 backplane is 5 VDC at 5.2 amps.

The Power Supply Extension cable must be secured before power is applied. It must not be disconnected during system operation.

## Slot Addressing

The Series 90-70 PLC system allows user configuration of I/O point references for modules in a rack without the need for board address DIP switches or jumpers. The address structure is described below. Configuration is done with the configurator function of the Logicmaster™ 90-70 Programming Software package. For more information on configuration, see GFK-0263, the Logicmaster 90 Programming Software User's Manual.

### Note

In order to configure slots 12PL to 19PL, you must have version 4.xx, or later of Logicmaster 90 Programming Software.

## Rack Number

Multiple racks in a system must be assigned a rack number from 0 to 7; the CPU rack is always Rack 0. The PLC determines the number of each rack in the system from the configuration of four binary-encoded jumpers on the rack's backplane. These jumpers are located on the backplane directly behind the power supply, which must be removed to gain access to the jumpers.

To set the rack number, move the jumpers corresponding to the 1, 2, 4, and 8 bits to either the 0 or 1 position. The sum of the digits in the 1 position equals the desired rack number. For example, as shown below, rack number 2 would have the 2 bit jumper in the 1 position and the 1, 4 and 8 bit jumpers in the 0 position.

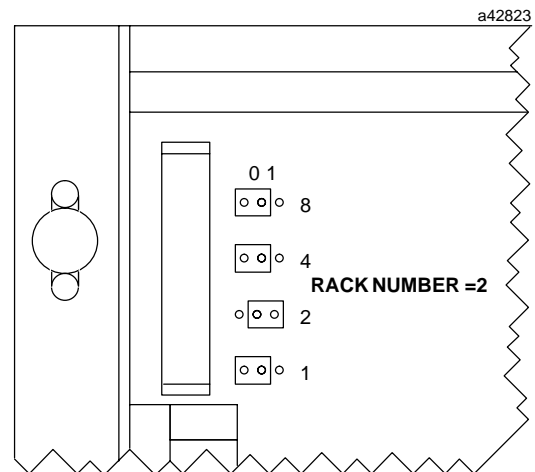

Figure F-5. Rack Number Jumpers

## Shield Ground

The bottom rail of the rack is used for module shield grounding. Some Series 90-70 I/O modules have a ground clip that contacts the conductive bottom rail when the module is fully inserted. Shield connections in the user connectors are routed to this ground clip through conductors on the module.

## Safety Ground

The ground lug on either side of the rack must be connected to earth ground with not less than an AWG #12 (3.3 mm<sup>2</sup>) wire. The ground lugs are #8-32.

### Warning

**If the ground lug is not connected to earth ground, the rack is not grounded. The rack must be grounded to minimize electrical shock hazard which may result in severe personal injury.**

## System Noise Immunity

Three easy steps must be taken to properly ground the Series 90-70 PLC system to reduce the possibility of errors due to electrical noise.

1. Make sure that the power supply mounting screws, especially the bottom two, are properly secured.
2. The GND terminal on the power supply must be connected to the GND terminal on either side of the rack using AWG # 12 wire. Use of a ring terminal and star washer is recommended.
3. The GND terminal on the rack must be connected to a good earth ground.

## Module Retention

Series 90-70 I/O modules have molded latches that automatically snap onto the upper and lower rails of the rack when the module is fully inserted (**3rd party VME modules do not have these latches**). Optionally, M2.5x8 screws may be used to secure the modules to the rack for high vibration applications.

To remove a Series 90-70 module, first remove the field half of the terminal board (if it is an I/O module), then grasp the top and bottom of the module to depress the latch releases while pulling the module out. For more detailed information on removing I/O terminal boards, refer to the *Series 90-70 Programmable Controller Installation Manual* or individual data sheets for I/O modules.

### Warning

**Do not remove (or insert) modules when either the Series 90-70 PLC power supply or any externally connected power sources are on. Hazardous voltages may exist. Personal injury, damage to the module or unpredictable operation of the device or process being controlled may result.**

If M2.5x8 screws have been used to secure modules to the rack, remove the screws before removing the modules.

A blank faceplate is available to cover two consecutive unused slots in the rack. See the Ordering Information on page F-12.



## Rack Fan Assembly

An optional Rack Fan Assembly is available in two versions (IC697ACC721 for 120 VAC power source and IC697ACC724 for 240 VAC power source) for installation on the bottom of the rack for additional cooling if forced air cooling is required when a number of high-power VME modules are installed in the rack and heat build-up could be a problem.

The fan assembly consists of three fans wired in parallel. The fans have a low noise level and are assembled using ball bearings for extended life.

The three fans on the fan assembly are wired in parallel. The fan on the left (looking at front of rack) has a three foot cable to be wired to the AC power source.

The other two fans are connected through a cable/connector assembly to this fan. It is recommended that the fans be wired to the same source of power as the Series 90-70 PLC so that the fans are energized regardless of whether or not the PLC is energized. This will ensure that the fans are running when the PLC is active.

The following illustration shows the position of the fan assembly when it is mounted on a rack. Note that it is mounted on the bottom of the rack with air flow from the bottom towards the top of the rack. For detailed specifications and installation instructions, refer to the data sheet for the Rack Fan Assembly, GFK-0637D, or later version.

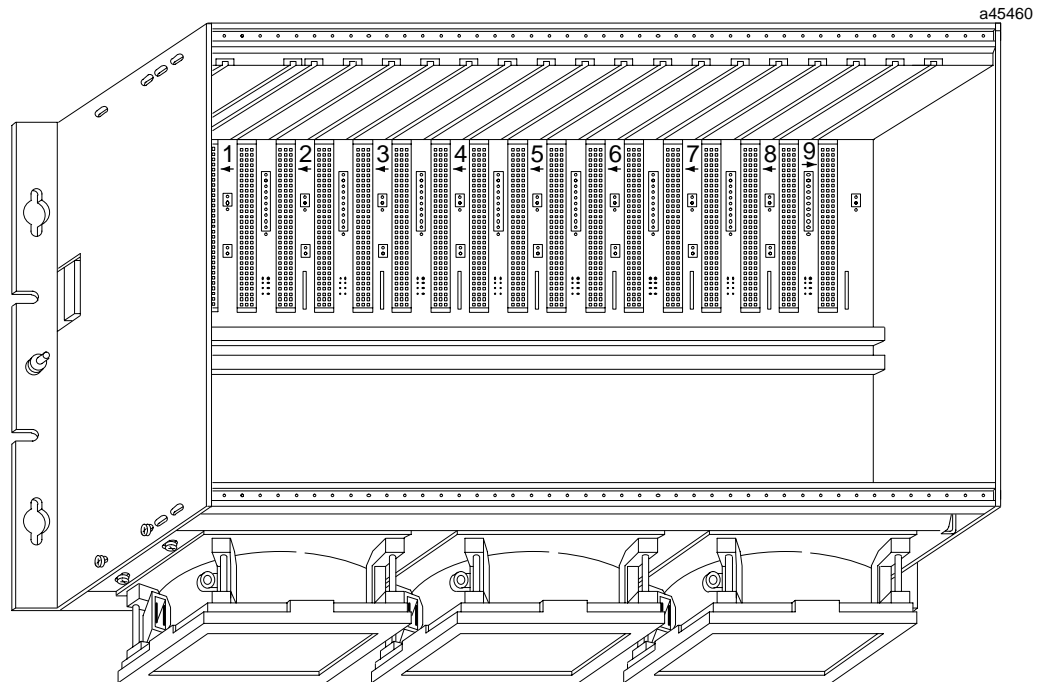

Figure F-6. Fan Assembly Mounted on Rack

**Table F-2. VME Integrator Rack Specifications**

<b>Number of Slots:</b>	17 on 0.8 inch centers plus power supply slot		
<b>Maximum 5 Volt Current (from standard Series 90-70 power supplies):</b>	20 amps (100 watt 120/240 VAC or 125 VDC power supply) 11 amps (55 watt 120/240 VAC or 125 VDC power supply) 18 amps (90 watt 24 VDC power supply) 18 amps (90 watt 48 VDC power supply)		
<b>Maximum current from user supplied (not Series 90-70) Power Supply, slot J1 only:</b>	3.3 amps (+5 VDC) 1.1 amps (Ç 12 VDC)		
<b>I/O References:</b>	User configurable with Logicmaster 90-70 configuration software.		
<b>Rack Identification:</b>	Four jumpers (JP1 - JP4) behind rack power supply.		
<b>VME/Series 90-70 slot configuration:</b>	Via jumpers on backplane (refer to text).		
<b>Dimensions- 17-Slot Rack:</b>	<i>Height</i> 11.15" 283mm	<i>Width</i> 19.00" 483mm	<i>Depth</i> 7.25" 184mm
<b>Note</b>			
All Series 90-70 modules extend 1.7" (43mm) beyond the front of the rack; 3rd party VME modules may fit flush with or extend from front of rack.			
<b>VME</b>	System designed to support VME standard C.1.		

Refer to GFK-0867B, or later for product standards and general specifications.

**Table F-3. VME Integrator Rack Ordering Information**

Description	Catalog Number
VME Integrator Rack - 17 slots, rear mount	IC697CHS782
VME Integrator Rack - 17 slots, front mount	IC697CHS783
Power Supply Cable Kit (includes cable and faceplate for vacant power supply slot)	IC697CBL700
Option Kit for J2 Backplane Installation (backplane not included)	IC697ACC715
Blank Slot Filler (Qty. 6)	IC697ACC720
Rack Fan Assembly (optional), 120 VAC	IC697ACC721
Rack Fan Assembly (optional), 240 VAC	IC697ACC724

*Appendix*  
***G***

*Application Bulletins*

---

---

This appendix provides examples of applications using 3rd party VME modules in the Series 90-70 PLC system.



# Application Bulletin

---

Number: H-03-91-6

To: 1, 2A, 3, 4, 8, 10, 11, 12

---

## Application Note for Xycom XVME-420 Intelligent Peripheral Controller Module

### Overview

The following application note describes a successful integration of a third party VME module into the Series 90-70 PLC system. Note that the Xycom XVME-420 is NOT a fully qualified third party module and has not gone through the Vendor Qualification Program. The application was not intended to represent a real situation, and was constructed only to demonstrate that the Xycom XVME-420 module could be successfully integrated, and made to work as described in its own manual.

The Xycom XVME-420 *Intelligent Peripheral Controller module* is ideally suited for cost sensitive applications which need more than 1 or 2 serial interfaces for devices such as terminals, bar code readers, and weigh scales. There are four RS-232 (or four TTL compatible) ports per module, as well as an IEEE-P959 expansion port. Internal buffering is available, so it is not necessary for the module to interrupt the CPU, or for the CPU to handle each serial character as it arrives at the port.

Although the module has many different programmable characteristics, the application described in this document is basic and uses two of the four ports. In this application, the module is NOT used as an interrupter, and is used only as a slave, not as a master on the VME bus. Once this application has been successfully duplicated, more complex applications can be attempted.

The XVME manual used for this demonstration was Xycom part number 74420 and was dated 1984.

### IMPORTANT NOTE

The standard XVME-420 module needs to be modified slightly to work with the Series 90-70 PLC. The standard module will not correctly recover from the SYSFAIL signal, which is asserted by the PLC during I/O configuration at power up. Xycom is aware of the modification which is required. When ordering this module, be sure to mention the modification.

### Application Description

A serial RS-232 Bar Code Reader was connected to port 1 to input data to the PLC. The PLC stores the bar code in registers, verifies it for the correct number of characters and then causes the bar code to be transmitted through port 2 of the module with a *BAD BAR CODE* error message if appropriate. A Dumb Terminal was connected to port 2 of the module to receive the *echoed* bar code and any error message due to mis-verification.

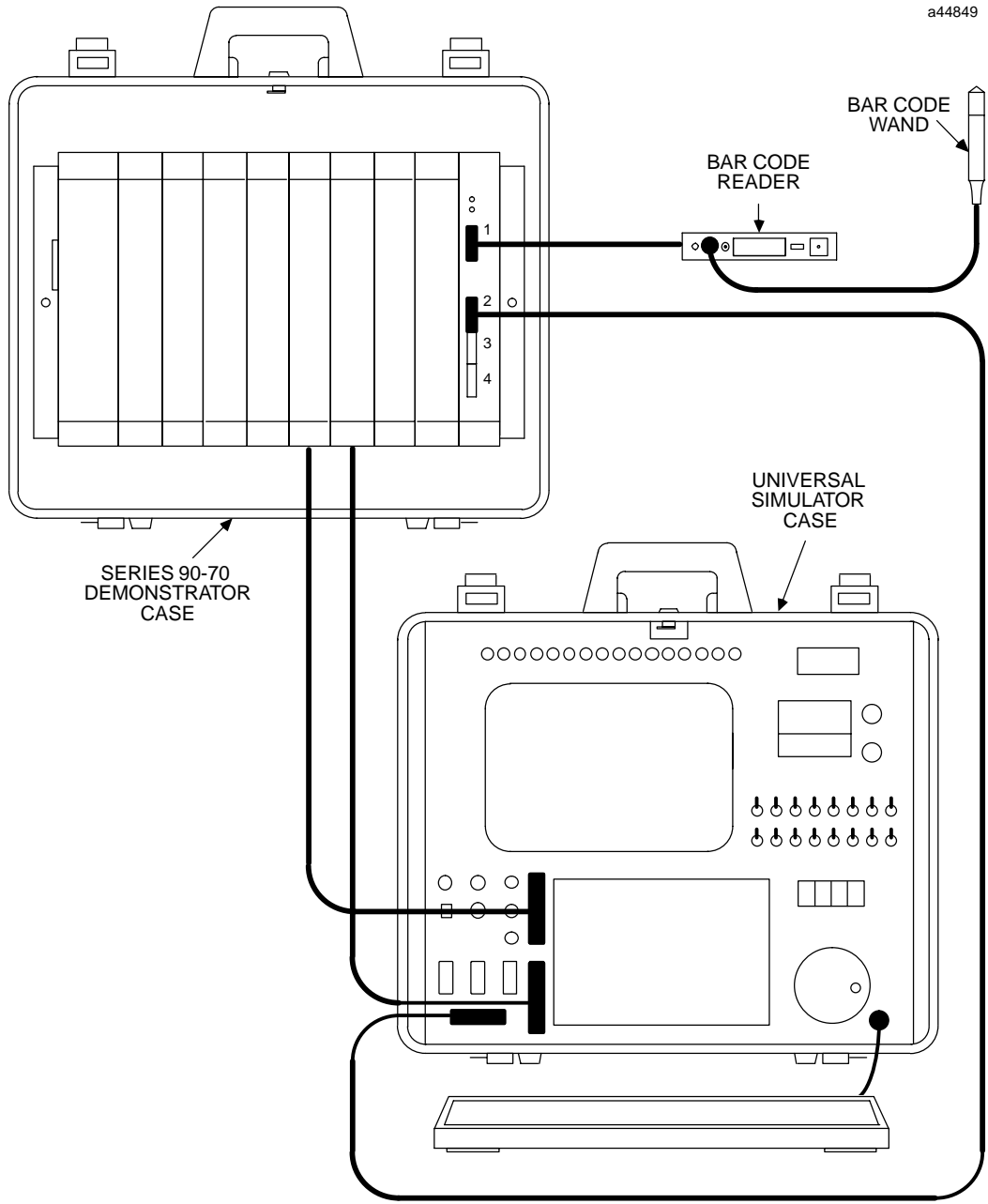

## System Configuration

The system configuration for this demonstration consists of the standard Series 90-70 Demo Case with a 100 watt power supply (*the module does require +/- 12 VDC*). All modules were left in the Series 90-70 Demo rack (with the exception of the power supply being changed to a 100 watt) and the XVME-420 was put in slot 9 which was previously empty. If a bar code reader is not available, it could be exchanged for a dumb terminal or a PC running terminal emulation software on which a bar code could be manually entered (typed). The XVME-420 defaults to look for a carriage return as the record terminator character, although it can be changed. The Universal Simulator Case display unit was used as the dumb terminal for Port 2. The XVME-420 ports default to 9600 baud, 8 bits/character, no parity, 1 stop bit, full duplex. The only thing that needs to be reconfigured at the universal simulator display unit is the baud rate from 19.2K to 9600 baud. For the demonstration, cables to and from the XVME-420 ports require only transmit, receive and ground to be wired.

The module must be assigned a starting address in the VME address space. You must use address modifier 2DH, and the address must be in the short address space. Although the manual states that AM code 29H can also be used, this will result in attempts by the module to access external global memory instead of its own on-board memory. The module uses 1K byte in the short address space, and the start address can be assigned to any one of 16 specific 1K byte boundaries ranging from 0000H to 3C00H. Note that the short address space that would be used by a Series 90-70 I/O module, for slot 9 of the Series 90-70 CPU rack starts at 4800H, which is outside of the range the XVME-420 can respond to.

To accommodate the XVME-420 in slot 9 for this demonstration, address 2800H was used, which is the start of the address space that would be used by a Series 90-70 I/O module, for slot 5. This is possible because the address modifier code used to get to the VME-420 is 2DH and NOT 29H. The discrete I/O module in slot 5 of the demo cases does not respond to AM code 2DH so there is no conflict between the two modules. Base address 2800H was set with J4 and J7 IN, and with J5 and J8 OUT. In general, any previously unused short VME address space can be used by a 3rd party module.

The bus request jumpers were set to J1=A, J2=B, J6=A. These should not have any effect since the board will not be used as a master.

Jumpers J10-J13 were all set to the A position, and J15-J16 were set to the B position. This is NOT as described in the manual, but it was the way the product was shipped to us, and Xycom confirmed that it was correct. The explanation for the difference is that these jumpers may be set differently depending on the types of memory devices used on the module.

The application was done with J3 IN, but this may work better with J3 OUT. J3=OUT restricts the module to responding to address modifier 2DH instead of 2DH and 29H.

## Programming

All of the serial operating parameters such as baud rate, parity, stop bits, and others are programmable on a port by port basis. As noted above, the power-up default parameters were used for this demonstration (the entire power up default list is on page 4-25 of the Xycom manual).

There are 2 basic modes of operation - character read/write, and record read/write. Character read/write basically turns the board into a four port USART, and requires that the Series 90-70 CPU handle each character individually. This would have severely limited the baud rate which could be handled without missing characters coming into the port, and would have required the construction of a PLC based buffer handler for the data.

The record read/write mode was used, since this takes advantage of the internal buffers on the module. This application closely followed the example in the Xycom manual on page 3-12 to 3-14 (reading a record under polled operation).

With reference to this example, the host base address is 0, the base address of the I/O interface block is 2800H, the command block is at 2A00H, the data buffer is at 2A14H, and the command is set to read a maximum of 48 bytes.

As noted above, with the default board parameters, the *end of record* for incoming data is defined as a carriage return. If more than 48 characters arrive before a carriage return arrives, then only the first 48

characters will be available in the buffer. There are several other ways to configure the XVME-420 to terminate a record including ending the record if a specific number of characters has arrived.

The following describes what is necessary to receive a record on port 1 of the XVME-420. Since the default port and module parameters were used, the remaining tasks for the Series 90-70 CPU are to:

1. Write the *commandblock* described below to address 2A00H. There is nothing magic about address 2A00H except that it is in the module's dual ported address space, and it is not used for anything else. The command block basically tells the module/port what to do. But it doesn't do it until it gets a go command (see item 3). For the Series 90-70, you **MUST** use an AM code of 2DH at address 2A0DH in the command block or the module might (depending on J3 jumper setting) use its inherent mastership capability to attempt an access of the external (non-existent) global memory and cause erroneous operation of the CPU.
2. Write the *commandblock pointer* described below to address 2892H. The command block pointer for each port is at its own fixed location in memory compared to the base of 2800H, and tells the module where to find the command block (item 1 above). Remember you **MUST** use an AM code of 2DH at address 2893H or the CPU might crash as described above in item 1.
3. Write 01H to the I/O channel 1 request register at 2882H. This tells the module to look at 2892H to find out where its command is, then execute the command.
4. When the command block is written in step 1, addresses 2A06H and 2A02H are set to FF. These are the *response word* and *response flag* respectively. When the CARRIAGE RETURN is received on the port, indicating the end of record, the FF is set to a 0 by the module. The CPU must poll 2A06H to see if the record is complete. If so, then go to step 5.

If the command block contains an invalid command, the address 2A02H will contain a non-0 error code.

5. After the above steps are completed, the data block can be read at address 2A14H by the 90-70 CPU. The command block which we used for the read record function is:

<u>Address</u>	<u>Even</u>	<u>Odd</u>
2A00H	00	05 (06 for a write record)
2A02H	FF	FF
2A04H	00	00
2A06H	FF	FF
2A08H	00	00
2A0AH	00	00
2A0CH	00	2D † <i>DON'TUSE29H</i>
2A0EH	00	00
2A10H	2A	14
2A12H	00	00

The command block pointer is:

2892H	00	2D † <i>DON'TUSE29H</i>
2894H	00	00
2896H	2A	00

Writing a record out of port 2 is almost identical to the above description, except you first have to write the data you want to transmit to the module's dual ported address space (unless it is already there, as it is with the bar code). Change the command to 06H instead of 05H and write the command block pointer for port 2 instead of port 1 (starts at address 2898H instead of 2892H. Also to execute the command, write 01H to the I/O channel 2 request register at 2883H instead of 2882H.

A commented ladder program is included on the following pages.

02-14-91 16:22 GE FANUC SERIES 90-70 DOCUMENTATION (v2.04) Page 1  
Demonstration Program for XYCOM XVME-420

MAIN PROGRAM STRUCTURE

```
MAIN
+---BAR_RDR
    +-----INIT
    +-----RECV
    +-----VERIFY
    +-----TRANS
        +---BADCODE
```

PROGRAM BLOCK CALL COUNT

BLOCK NAME / CALL COUNT

```
BAR_RDR      1
INIT         1
RECV         1
TRANS        1
BADCODE      1
VERIFY       1
```

Program: XYCOM

C:\LM90\XYCOM



02-14-91 16:22 GE FANUC SERIES 90-70 DOCUMENTATION (v2.04) Page 2  
 Demonstration Program for XYCOM XVME-420

```

| << RUNG 0 >>
|
| [ START OF LD PROGRAM XYCOM ]
|
| << RUNG 1 >>
|
| [ VARIABLE DECLARATIONS ]
|
| << RUNG 2 >>
|
- [ START OF PROGRAM BLOCK DECLARATIONS ]
|
| +-----+ (* BAR CODE READER INTERFACE *)
| | BAR_RDR |
| +-----+
|
| +-----+ (* INITIALIZE COMMANDS *)
| | INIT |
| +-----+
|
| +-----+ (* SEND READ RECORD CMMD TO CHAN 0 *)
| | RECV |
| +-----+
|
| +-----+ (* SEND WRITE RECORD CMMD TO CHAN 1 *)
| | TRANS |
| +-----+
|
| +-----+ (* XMIT BAD BAR CODE MSG *)
| | BADCODE |
| +-----+
|
| +-----+ (* VERIFY BAR CODE *)
| | VERIFY |
| +-----+
|
- [ END OF PROGRAM BLOCK DECLARATIONS ]
|
| << RUNG 3 >>
|
- [ START OF INTERRUPTS ]
|
|
- [ END OF INTERRUPTS ]
|
Program: XYCOM C:\LM90\XYCOM Block: _MAIN

```

02-14-91 16:22 GE FANUC SERIES 90-70 DOCUMENTATION (v2.04) Page 3  
Demonstration Program for XYCOM XVME-420

<< RUNG 4 >>

[ START OF PROGRAM LOGIC ]

<< RUNG 5 >>

+-----+  
+CALL BAR\_RDR+  
+-----+

[ END OF PROGRAM LOGIC ]

Program: XYCOM

C:\LM90\XYCOM

Block: \_MAIN

02-14-91 16:22 GE FANUC SERIES 90-70 DOCUMENTATION (v2.04) Page 4  
 Demonstration Program for XYCOM XVME-420

```

<< RUNG 0 >>

+[ START OF LD BLOCK BAR_RDR ]

<< RUNG 1 >>

[ VARIABLE DECLARATIONS ]

<< RUNG 2 >>

+[ START OF BLOCK LOGIC ]

<< RUNG 3 >>

FST_SCN
%S00001 +-----+
--] [-----+CALL INIT +
+-----+

<< RUNG 4 >>

LENGTH
(* COMMENT *)

(*****
(* Read a value from the Thumbwheel switches which will be used for the *)
(* length verification of the barcode. The value is stored in %R501 when *)
(* %I0001 is closed. *)
(*****

<< RUNG 5 >>

SETLNGT
%I00001 +-----+
--] [----+ BCD4+--
      |   |
      |   | TO_ |
      |   | UINT|
THUM_WH | UINT|
%I00017--+IN Q+--%R00501
      +-----+

<< RUNG 6 >>

STRTRVY STRTXMT STRTRCV
%M00013 %M00014 %M00001
--]/[-----]/[----- (SM) --

Program: XYCOM C:\LM90\XYCOM Block: BAR_RDR
  
```

02-14-91 16:22 GE FANUC SERIES 90-70 DOCUMENTATION (v2.04) Page 5  
Demonstration Program for XYCOM XVME-420

```
<< RUNG 7 >>
ALW_ON STRTXMT
%S00007 %M00014
+--] [----- (RM) -

<< RUNG 8 >>
STRTRCV
%M00001 %M00100
+--] [----- (^) --

<< RUNG 9 >>
STRTRCV
%M00001 +-----+
+--] [-----+CALL RECV +
+-----+

<< RUNG 10 >>
STRTRCV
%M00013 +-----+
+--] [-----+CALL VERIFY +
+-----+

<< RUNG 11 >>
STRTXMT
%M00014 +-----+
+--] [-----+CALL TRANS +
+-----+

+[ END OF BLOCK LOGIC ]
```

Program: XYCOM

C:\LM90\XYCOM

Block: BAR\_RDR

02-14-91 16:22 GE FANUC SERIES 90-70 DOCUMENTATION (v2.04) Page 6  
Demonstration Program for XYCOM XVME-420

```
<< RUNG 0 >>

+[ START OF LD BLOCK INIT ]

<< RUNG 1 >>

[ VARIABLE DECLARATIONS ]

<< RUNG 2 >>

+[ START OF BLOCK LOGIC ]

<< RUNG 3 >>

INIT1
(* COMMENT *)

(*****
(* Initialize the command block which causes the XVME-420 to read a record. *)
*****)
```

Program: XYCOM

C:\LM90\XYCOM

Block: INIT

02-14-91 16:22 GE FANUC SERIES 90-70 DOCUMENTATION (v2.04)  
Demonstration Program for XYCOM XVME-420

Page 7

<< RUNG 4 >>

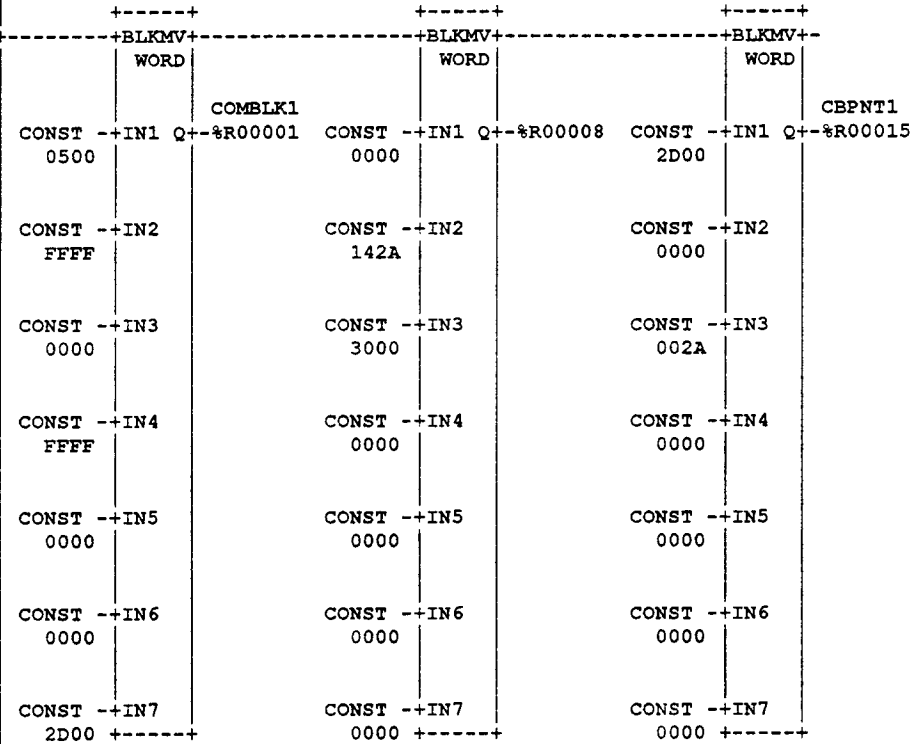

<< RUNG 5 >>

```

INIT2
(* COMMENT *)

(*****
(* Initialize the command block which causes the XVME-420 to write a      *)
(* record (the message "BAD BAR CODE").                                     *)
(*****

```

Program: XYCOM

C:\LM90\XYCOM

Block: INIT

# Application Note for Xycom XVME-420 Intelligent Peripheral Controller Module

```

02-14-91 16:22 GE FANUC SERIES 90-70 DOCUMENTATION (v2.04) Page 8
Demonstration Program for XYCOM XVME-420

<< RUNG 6 >>

+-----+ +-----+ +-----+
+BLKMV+ +BLKMV+ +BLKMV+
| WORD | | WORD | | WORD |
|       | |       | |       |
| CMDBLK2 | |       | | CBPTR2 |
CONST --IN1 Q+--%R00031  CONST --IN1 Q+--%R00038  CONST --IN1 Q+--%R00045
0600 | | 0000 | | 2D00 |
|       | |       | |       |
CONST --IN2 | | CONST --IN2 | | CONST --IN2 |
FFFF | | 6A2A | | 0000 |
|       | |       | |       |
CONST --IN3 | | CONST --IN3 | | CONST --IN3 |
0000 | | 1100 | | 002A |
|       | |       | |       |
CONST --IN4 | | CONST --IN4 | | CONST --IN4 |
FFFF | | 0000 | | 0000 |
|       | |       | |       |
CONST --IN5 | | CONST --IN5 | | CONST --IN5 |
0000 | | 0000 | | 0000 |
|       | |       | |       |
CONST --IN6 | | CONST --IN6 | | CONST --IN6 |
0000 | | 0000 | | 0000 |
|       | |       | |       |
CONST --IN7 | | CONST --IN7 | | CONST --IN7 |
2D00 +-----+ | | 0000 +-----+ | | 0000 +-----+

<< RUNG 7 >>

INIT3
(* COMMENT *)

(*****
(* Initialize the registers that store the ASCII characters that make up *)
(* the message "BAD BAR CODE". *)
(*****

Program: XYCOM C:\LM90\XYCOM Block: INIT

```

02-14-91 16:22 GE FANUC SERIES 90-70 DOCUMENTATION (v2.04) Page 9  
Demonstration Program for XYCOM XVME-420

<< RUNG 8 >>

	+-----+		+-----+
	BLKMOV		MOVE
	WORD		WORD
CONST --IN1 Q--%R00061	MSG1	CONST --IN Q--%R00068	
0A0A		003A	LEN
			001
CONST --IN2			
4142			
CONST --IN3			
2044			
CONST --IN4			
4142			
CONST --IN5			
2052			
CONST --IN6			
4F43			
CONST --IN7			
4544	+-----+		

<< RUNG 9 >>

INIT4  
(\* COMMENT \*)  
  
 (\*\*\*\*\*)  
 (\* Initialize the registers that store the command block which causes the \*)  
 (\* XVME-420 to transmit a record (echo the bar code that was just read). \*)  
 (\*\*\*\*\*)

Program: XYCOM

C:\LM90\XYCOM

Block: INIT



Application Note for Xycom XVME-420 Intelligent Peripheral Controller Module

02-14-91 16:22 GE FANUC SERIES 90-70 DOCUMENTATION (v2.04)  
Demonstration Program for XYCOM XVME-420

Page 10

<< RUNG 10 >>

+-----+		+-----+		+-----+	
BLKMOV		BLKMOV		BLKMOV	
WORD		WORD		WORD	
CONST --IN1 Q+-%R00091	CMDBLK3	CONST --IN1 Q+-%R00098		CONST --IN1 Q+-%R00105	CBPTR3
0600		0000		2D00	
CONST --IN2		CONST --IN2		CONST --IN2	
FFFF		142A		0000	
CONST --IN3		CONST --IN3		CONST --IN3	
0000		3000		002A	
CONST --IN4		CONST --IN4		CONST --IN4	
FFFF		0000		0000	
CONST --IN5		CONST --IN5		CONST --IN5	
0000		0000		0000	
CONST --IN6		CONST --IN6		CONST --IN6	
0000		0000		0000	
CONST --IN7		CONST --IN7		CONST --IN7	
2D00 +-----+		0000 +-----+		0000 +-----+	

+ [ END OF BLOCK LOGIC ]

Program: XYCOM

C:\LM90\XYCOM

Block: INIT

02-14-91 16:22 GE FANUC SERIES 90-70 DOCUMENTATION (v2.04) Page 11  
Demonstration Program for XYCOM XVME-420

```

<< RUNG 0 >>

+[ START OF LD BLOCK RECV ]

<< RUNG 1 >>

[ VARIABLE DECLARATIONS ]

<< RUNG 2 >>

+[ START OF BLOCK LOGIC ]

<< RUNG 3 >>

RCV_CB
(* COMMENT *)

(*****)
(* When the receive block is active the following command is written to *)
(* port 1 on the Xycom module: *)
(* *)
(* 1R = 0500 = Xycom command #5 = Read Record Command. *)
(* 2R = FFFF = Response word set to FFFF so board can respond with *)
(* 0000 which means command complete O.K. or some other *)
(* value which is error code. *)
(* 3R = 0000 = No interrupts used. *)
(* 4R = FFFF = Upper byte means no command block chaining. *)
(* Lower byte is response flag which will get set to 0000 *)
(* when command is complete. *)
(* 5R = 0000 = Don't care. *)
(* 6R = 0000 = Don't care. *)
(* 7R = 2D00 = AM Code for dual access memory. *)
(* 8R = 0000 = Upper byte of address of data buffer on Xycom board. *)
(* 9R = 142A = Lower bytes of address of data buffer on Xycom board. *)
(* 10R = 3000 = Maximum number of characters to read (48 decimal). *)
(* *)
(* The Xycom board is addressed at 2800h. The first 200h addresses are *)
(* used by the board for: storage of identification data *)
(* I/O request registers *)
(* Command block pointer storage *)
(* Channel status and character buffers. *)
(* *)
(* This command is written to address 2A00 on the Xycom board. *)
(*****)

```

Program: XYCOM

C:\LM90\XYCOM

Block: RECV

Application Note for Xycom XVME-420 Intelligent Peripheral Controller Module

<< RUNG 4 >>

```

%M00100          +-----+                               %M00002
+--] [-----+ VME +-----+----- (SM) -
                WRT_
                BYTE
COMBLK1         +IN
                LEN
                020
CONST --+AM
                002D
                +ADR
CONST --+ADR
                00002A00 +-----+

```

<< RUNG 5 >>

```

CB_PTR
(* COMMENT *)

(*****
(* This VME write, writes the starting address of the above command block *)
(* (2A00h) to port 1's "Command Block Pointer" (2892h). Address Modifier *)
(* 2D is used. *)
(*****

```

<< RUNG 6 >>

```

%M00002          +-----+                               %M00003
+--] [-----+ VME +-----+----- (SM) -
                WRT_
                BYTE
CBPNT1         +IN
                LEN
                006
CONST --+AM
                002D
                +ADR
CONST --+ADR
                00002892 +-----+

```

02-14-91 16:22 GE FANUC SERIES 90-70 DOCUMENTATION (v2.04) Page 13  
Demonstration Program for XYCOM XVME-420

<< RUNG 7 >>

CHK\_WRT

(\* COMMENT \*)

(\*\*\*\*\*  
(\* This VME read, reads the response flag and tests for FF to insure that \*)  
(\* the command block got written. \*)  
(\*\*\*)

<< RUNG 8 >>

```

%M00003          +-----+          +-----+
+---] [-----+ VME +-----+ EQ +---
                RD_          INT
                BYTE
CONST --+AM          CONST --+I1 Q-----+ %M00004
002D  LEN          +00255 (SM) -
                001
CONST --+ADR Q+-%L00001 %L00001--+I2
00002A06 +-----+          +-----+
    
```

<< RUNG 9 >>

EXECUTE

(\* COMMENT \*)

(\*\*\*\*\*  
(\* This VME write of a "1" to address 2882 (the I/O request reg for port 1) \*)  
(\* causes the read command to be executed. \*)  
(\*\*\*)

Application Note for Xycom XVME-420 Intelligent Peripheral Controller Module

02-14-91 16:22 GE FANUC SERIES 90-70 DOCUMENTATION (v2.04) Page 14  
Demonstration Program for XYCOM XVME-420

<< RUNG 10 >>

```

%M00004          +-----+                                %M00005
+---] [-----+ VME +-----+ (SM) -
                WRT_
                BYTE
                CONST --IN
                0001  LEN
                001
                CONST --AM
                002D
                CONST --ADR
                00002882 +-----+

```

<< RUNG 11 >>

```

%M00005          %M00002
+---] [-----+ (RM) -
                %M00003
                +-----+ (RM) -
                %M00004
                +-----+ (RM) -
                %M00005
                +-----+ (RM) -
                %M00006
                +-----+ (SM) -

```

<< RUNG 12 >>

```

CHK_RSP
(* COMMENT *)

(*****
(* The response word (2A02h) and response flag (2A06h) are read and tested *)
(* in the following two rungs. When they both go to 0 it means a bar code *)
(* has been received at port 1. *)
(*****

```

02-14-91 16:22 GE FANUC SERIES 90-70 DOCUMENTATION (v2.04) Page 15  
Demonstration Program for XYCOM XVME-420

<< RUNG 13 >>

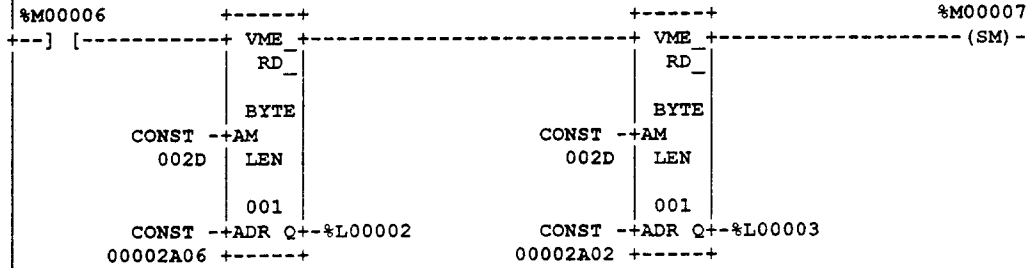

<< RUNG 14 >>

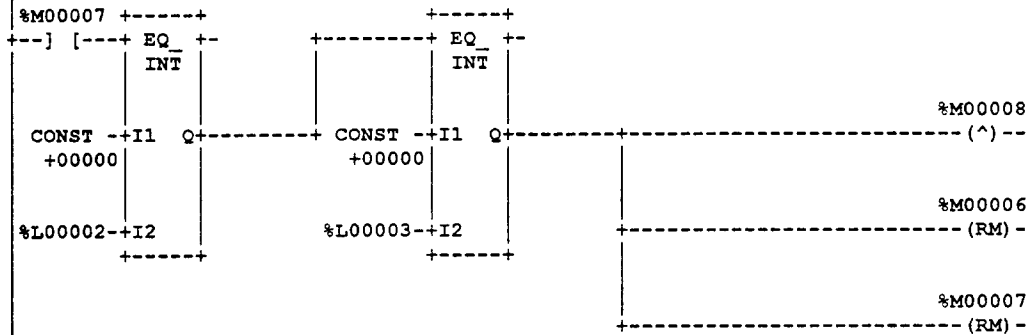

<< RUNG 15 >>

RD\_BUFF  
(\* COMMENT \*)

(\*\*\*\*\*)  
(\* Read the received bar code from where it was buffered at 2A14h and store \*)  
(\* it in 201R - 248R. \*)  
(\* \*)  
(\* \*)  
(\*\*\*)

Application Note for Xycom XVME-420 Intelligent Peripheral Controller Module

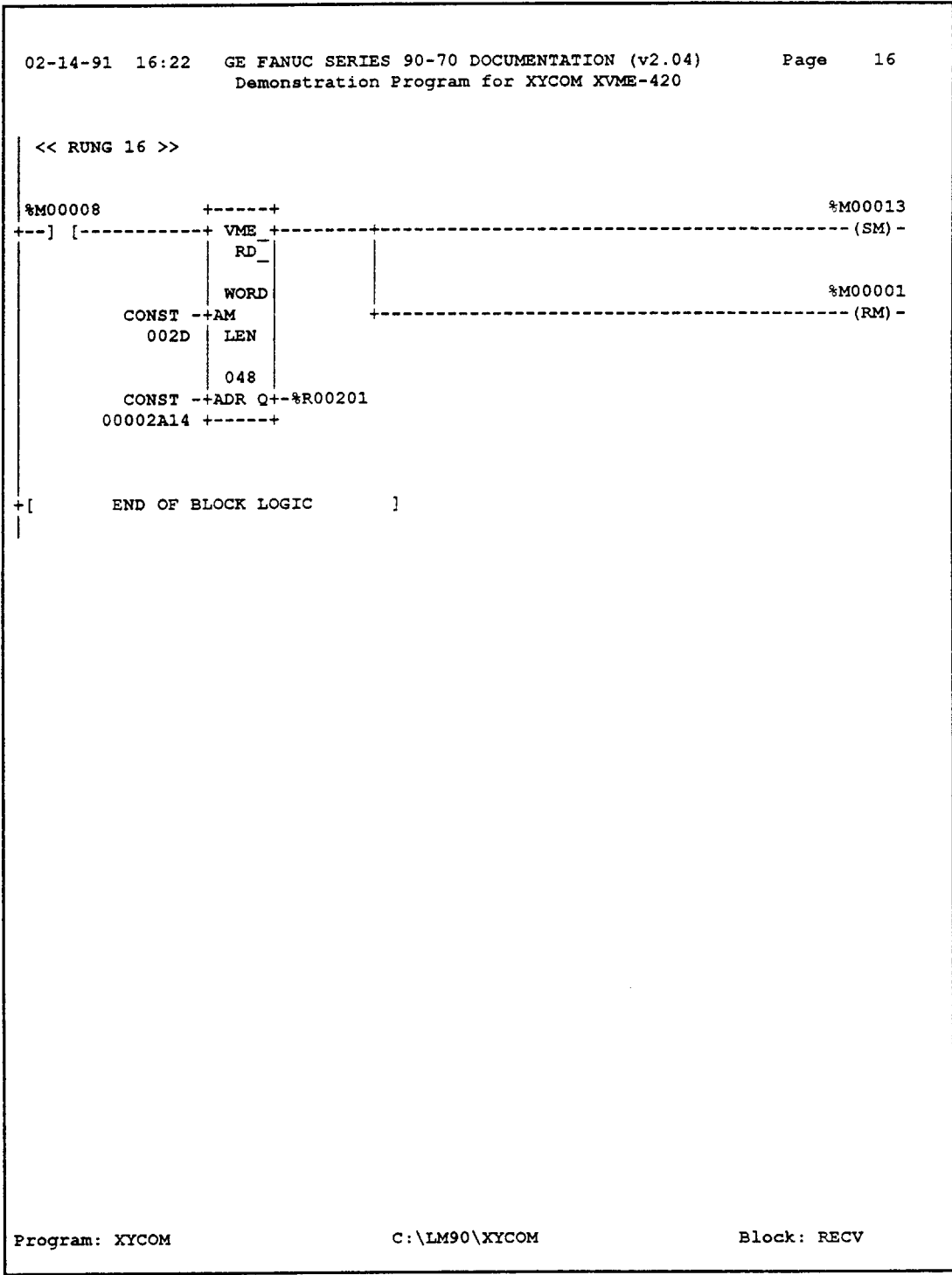

```
02-14-91 16:22 GE FANUC SERIES 90-70 DOCUMENTATION (v2.04) Page 17
                Demonstration Program for XYCOM XVME-420

<< RUNG 0 >>

+[ START OF LD BLOCK TRANS ]

<< RUNG 1 >>

[ VARIABLE DECLARATIONS ]

<< RUNG 2 >>

+[ START OF BLOCK LOGIC ]

<< RUNG 3 >>

BADCODE
(* COMMENT *)

(*****
(* %Q0001 = On if length is not equal to that previously programmed with *)
(* the thumbwheel switch. If length is verified OK (%Q0001 = then the *)
(* BADCODE program block is not executed and the "BAD BAR CODE" error *)
(* message does not get transmitted with the bar code value. *)
(*****

<< RUNG 4 >>

%Q00001 +-----+
+---] [---+CALL BADCODE+
          +-----+

<< RUNG 5 >>

WRT_CB
(* COMMENT *)

Program: XYCOM                C:\LM90\XYCOM                Block: TRANS
```



## Application Note for Xycom XVME-420 Intelligent Peripheral Controller Module

02-14-91 16:22 GE FANUC SERIES 90-70 DOCUMENTATION (v2.04) Page 18  
 Demonstration Program for XYCOM XVME-420

```
(*****)
(* When the transmit block is active the following command is written to *)
(* port 2 on the Xycom module: *)
(* *)
(* 1R = 0600 = Xycom command #6 = Write Record Command. *)
(* 2R = FFFF = Response word set to FFFF so board can respond with *)
(* 0000 which means command complete O.K. or some other *)
(* value which is error code. *)
(* 3R = 0000 = No interrupts used. *)
(* 4R = FFFF = Upper byte means no command block chaining. *)
(* Lower byte is response flag which will get set to 0000 *)
(* when command is complete. *)
(* 5R = 0000 = Don't care. *)
(* 6R = 0000 = Don't care. *)
(* 7R = 2D00 = AM Code for dual access memory. *)
(* 8R = 0000 = Upper byte of address of data buffer on Xycom board. *)
(* 9R = 142A = Lower bytes of address of data buffer on Xycom board. *)
(* Start of buffer where previously read bar code value is *)
(* stored. *)
(* 10R = 3000 = Maximum number of characters to write (48 decimal). *)
(*****)
```

<< RUNG 6 >>

```
ALW ON
%S00007 +-----+ %M00025
+--] [-----+ VME +-----+ (SM)-
          WRT_
          CMDBLK3 BYTE
          %R00091--IN
          LEN
          020
          CONST --+AM
          002D
          CONST --+ADR
          00002A00 +-----+
```

<< RUNG 7 >>

```
CB_PTR
(* COMMENT *)
```

```
(*****)
(* This VME write, writes the starting address of the above command block *)
(* (2A00h) to port 2's "Command Block Pointer" (2898h). Address Modifier *)
(* 2D is used. *)
(*****)
```

Program: XYCOM

C:\LM90\XYCOM

Block: TRANS

```
02-14-91  16:22  GE FANUC SERIES 90-70 DOCUMENTATION (v2.04)        Page   19
              Demonstration Program for XYCOM XVME-420
```

```
<< RUNG 8 >>
```

```
%M00025          +-----+                               %M00026
+-- ] [-----+  VME_+----- (SM) -
                WRT_
                  |
CBPTR3          BYTE
%R00105--+IN
              |
              LEN
                  |
              006
CONST -+AM
          |
          002D
                |
CONST -+ADR
          |
          00002898 +-----+
```

```
<< RUNG 9 >>
```

```
EXECUTE
```

```
(* COMMENT *)
```

```
(*****
(* This VME write of a "1" to address 2883 (the I/O request reg for port 2) *)
(* causes the write command to be executed. *)
(*****
```

```
<< RUNG 10 >>
```

```
%M00026          +-----+
+-- ] [-----+  VME_+-----
                WRT_
                  |
                  BYTE
CONST -+IN
          |
          0001  LEN
                  |
                  001
CONST -+AM
          |
          002D
                |
CONST -+ADR
          |
          00002883 +-----+
```

02-14-91 16:22 GE FANUC SERIES 90-70 DOCUMENTATION (v2.04) Page 20  
Demonstration Program for XYCOM XVME-420

```
<< RUNG 11 >>
ALW_ON
%S00007 +-----+
+---] [---+ BLK_ +---+
          | CLR_
          |
          | WORD
%M00017--+IN
          | LEN
          | 003
          +-----+

+[      END OF BLOCK LOGIC      ]
```

Program: XYCOM

C:\LM90\XYCOM

Block: TRANS

02-14-91 16:22 GE FANUC SERIES 90-70 DOCUMENTATION (v2.04) Page 21  
Demonstration Program for XYCOM XVME-420

<< RUNG 0 >>

+ [ START OF LD BLOCK BADCODE ]

<< RUNG 1 >>

[ VARIABLE DECLARATIONS ]

<< RUNG 2 >>

+ [ START OF BLOCK LOGIC ]

<< RUNG 3 >>

MSG  
(\* COMMENT \*)

(\*\*\*\*\*  
(\* Write the ASCII characters that make up the message "BAD BAR CODE" which \*)  
(\* are stored starting at %R601, to the shared ram on the XVME-420 at \*)  
(\* address 2A6AH, so that they can be transmitted by the execution of the \*)  
(\* command written by the next rung below. \*)  
(\*\*\*)

<< RUNG 4 >>

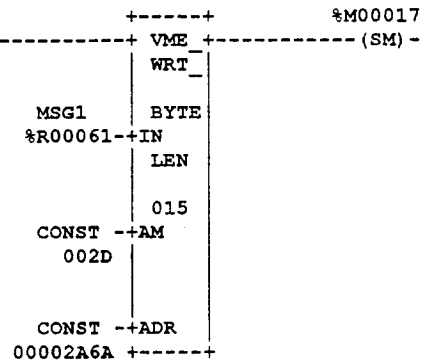

<< RUNG 5 >>

WRT\_CB  
(\* COMMENT \*)

Program: XYCOM

C:\LM90\XYCOM

Block: BADCODE

## Application Note for Xycom XVME-420 Intelligent Peripheral Controller Module

02-14-91 16:22 GE FANUC SERIES 90-70 DOCUMENTATION (v2.04) Page 22  
 Demonstration Program for XYCOM XVME-420

```

    (*****
    (* When the badcode block is active the following command is written to *)
    (* port 2 on the Xycom module: *)
    (* *)
    (* 1R = 0600 = Xycom command #6 = Write Record Command. *)
    (* 2R = FFFF = Response word set to FFFF so board can respond with *)
    (* 0000 which means command complete O.K. or some other *)
    (* value which is error code. *)
    (* 3R = 0000 = No interrupts used. *)
    (* 4R = FFFF = Upper byte means no command block chaining. *)
    (* Lower byte is response flag which will get set to 0000 *)
    (* when command is complete. *)
    (* 5R = 0000 = Don't care. *)
    (* 6R = 0000 = Don't care. *)
    (* 7R = 2D00 = AM Code for dual access memory. *)
    (* 8R = 0000 = Upper byte of address of data buffer on Xycom board. *)
    (* 9R = 6A2A = Lower bytes of address of data buffer on Xycom board. *)
    (* (Start of buffer where the message BAD BAR CODE is stored.) *)
    (* 10R = 1100 = Maximum number of characters to write (17 decimal). *)
    (*****
  
```

<< RUNG 6 >>

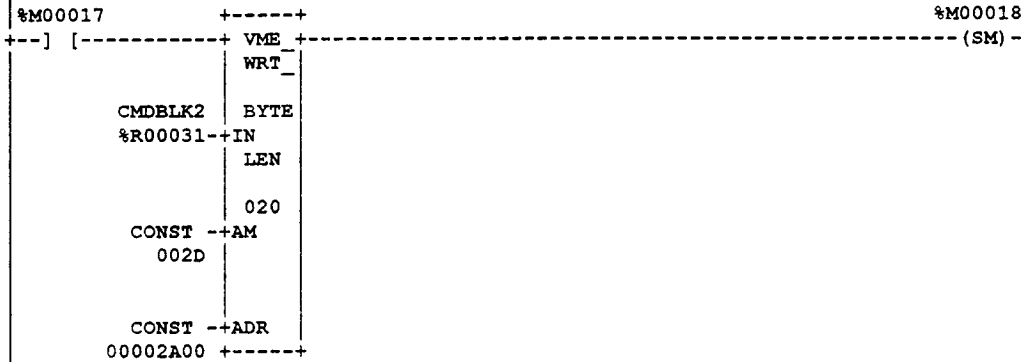

<< RUNG 7 >>

```

CB_PTR
(* COMMENT *)
  
```

```

    (*****
    (* This VME write, writes the starting address of the above command block *)
    (* (2A00h) to port 2's "Command Block Pointer" (2898h). Address Modifier *)
    (* 2D is used. *)
    (*****
  
```

Program: XYCOM

C:\LM90\XYCOM

Block: BADCODE

02-14-91 16:22 GE FANUC SERIES 90-70 DOCUMENTATION (v2.04) Page 23  
Demonstration Program for XYCOM XVME-420

<< RUNG 8 >>

```
%M00018          +-----+                                %M00019
+--] [-----+ VME -----+ (SM)-
                | WRT |
                +---+
                |     |
                | CBPTR2 | BYTE
                | %R00045 | IN
                |     |
                |     | LEN
                |     |
                |     | 006
                | CONST --+AM
                | 002D |
                |     |
                |     |
                | CONST --+ADR
                | 00002898 |
                +-----+
```

<< RUNG 9 >>

EXECUTE

(\* COMMENT \*)

```
(*****
(* This VME write of a "1" to address 2883 (the I/O request reg for port 2) *)
(* causes the write command to be executed. *)
(*****
```

<< RUNG 10 >>

```
%M00019          +-----+                                %M00021
+--] [-----+ VME -----+ (SM)-
                | WRT |
                +---+
                |     |
                |     |
                | CONST --+IN
                | 0001 | LEN
                |     |
                |     |
                |     | 001
                | CONST --+AM
                | 002D |
                |     |
                |     |
                | CONST --+ADR
                | 00002883 |
                +-----+
```

02-14-91 16:22 GE FANUC SERIES 90-70 DOCUMENTATION (v2.04) Page 24  
 Demonstration Program for XYCOM XVME-420

<< RUNG 11 >>

```

%M00021          +-----+
+--] [-----+ VME +-----+ VME +
                |RD |      |RD | | |
                |   |      |   |
                |BYTE|      |BYTE|
                |   |      |   |
                |CONST --AM|  |CONST --AM|
                | 002D |LEN|  | 002D |LEN|
                |   |      |   |
                | 001 |      | 001 |
                |CONST --ADR Q+-%L00002|  |CONST --ADR Q+-%L00003|
                |00002A06 +-----+|  |00002A02 +-----+|
  
```

+ [ END OF BLOCK LOGIC ]

02-14-91 16:22 GE FANUC SERIES 90-70 DOCUMENTATION (v2.04) Page 25  
Demonstration Program for XYCOM XVME-420

<< RUNG 0 >>  
+[ START OF LD BLOCK VERIFY ]

<< RUNG 1 >>

[ VARIABLE DECLARATIONS ]

<< RUNG 2 >>

+[ START OF BLOCK LOGIC ]

<< RUNG 3 >>

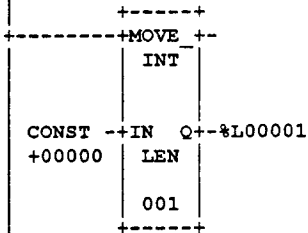

<< RUNG 4 >>

LENGTH  
(\* COMMENT \*)

```
(*****)  
(* Read the actual length of the received record where it is returned in *)  
(* the 18th and 19th bytes of the command block (XVME-420 memory address *)  
(* 2A13H). Subtract 2 from it to account for the carriage return and *)  
(* line feed from the bar code reader and output the length value on the *)  
(* universal simulator's 7-segment display at %Q0017.. *)  
(***)
```

Program: XYCOM

C:\LM90\XYCOM

Block: VERIFY



Application Note for Xycom XVME-420 Intelligent Peripheral Controller Module

<< RUNG 5 >>

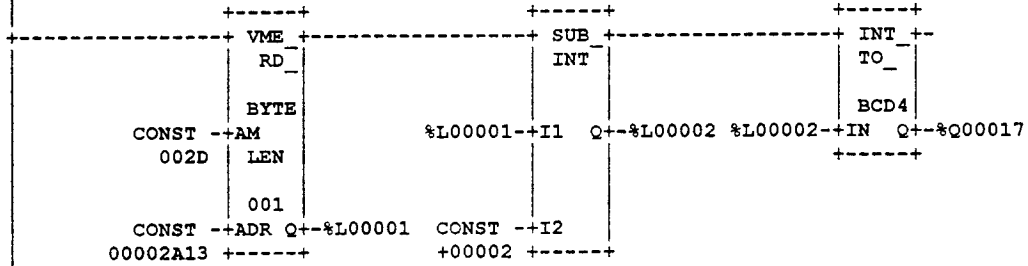

<< RUNG 6 >>

COMPARE

(\* COMMENT \*)

(\*\*\*\*\*  
 (\* Compare the actual length read from the XVME-420 with the value to be \*)  
 (\* tested for which was previously input from the thumbwheel switches into \*)  
 (\* %R501. %Q0001 is then used to enable or disable the transmission of the \*)  
 (\* message "BAD BAR CODE". \*)  
 (\*\*\*\*\*)

<< RUNG 7 >>

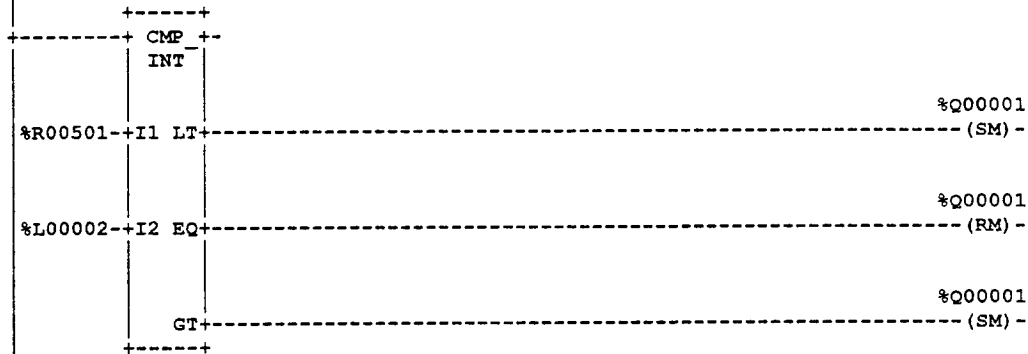

02-14-91 16:22 GE FANUC SERIES 90-70 DOCUMENTATION (v2.04) Page 27  
Demonstration Program for XYCOM XVME-420

<< RUNG 8 >>

ALW\_ON  
%S00007

%M00013

+ ] [ - +----- (RM) -

%M00014

+----- (SM) -

+ [ END OF BLOCK LOGIC ]

Program: XYCOM

C:\LM90\XYCOM

Block: VERIFY



---

## High Speed Inter-Rack Communications Using Reflective Memory

### SUMMARY

There has been considerable interest on the part of traditional VME users to apply the Series 90™-70 in their applications. Many users require a configuration which allows a Series 90-70 system to be tied to a separate VME system via a high speed inter-rack link. In addition, many Series 90-70 users need a very high speed communications link among multidropped Series 90-70 CPUs.

The VMIVME-5550, a product from VME Microsystems International, was investigated as a possible answer to these needs. A cursory investigation revealed that the VMIVME-5550 is essentially compatible with the Series 90-70 at the VME interface level, and would be useful in some applications. Some restrictions were identified, and are noted on the next page.

No attempt was made to simulate any specific *real* application beyond the testing for basic Series 90-70 compatibility, and the actual transmission of data between the Series 90-70 systems.

### OVERVIEW

The VMIVME-5550 is a *reflective memory* board. Its primary use is to connect multiple VME and/or Series 90-70 racks together in a multidrop parallel communications link. Each rack must have a master, which can read and write memory on the 5550 board. In a Series 90-70 system, the Series 90-70 CPU is the master. In a more general case, the master is typically a CPU based on a Motorola 680X0 chip.

The inter-rack link can be up to 1000 feet long, with up to 16 nodes on the bus. The bus can run at 20 Mbytes per second over short distances between compatible VME systems. In the Series 90-70 the transfer rate is limited to 10 Mbytes per second due to absence of Lword transfers. Long cables also restrict the maximum data rate.

Any data written by a master to one of the cards is transmitted immediately to all other nodes on the bus to the same relative address in the other cards.

The 5550 might be useful in applications which require

- A high speed communication link between Series 90-70 racks.
- A high speed communication link between Series 90-70 racks and standard VME racks.
- Data sharing between separate systems.
- A Genius™ tie-in to a traditional VME based computer. This would be done using a standard Series 90-70 and Genius Bus Controller, with a CPU program providing the data transfer between the CPU Genius I/O tables and the reflective memory board.

The board is a single wide 6U board, which contains both J1 and J2 connectors. The board is available with different amounts of memory. As tested, the modules contained 256K of dual ported memory, and a 512 byte FIFO. This was the least expensive configuration. Per VMIC's price list of February 1991, these modules would cost \$2195 each in small quantities. This configuration appears to be more than adequate for use in most Series 90-70 related systems.

## RESTRICTIONS

Application restrictions which were noted are as follows:

- The board needs 7A at 5V to operate. In many instances, the 100W Series 90-70 power supply would be required to support a configuration which includes this board. A detailed power analysis should be done before deciding on the 55W supply.
- A P2 backplane would be strongly recommended due to the power consumption of the board. The board was run successfully using only a J1 backplane, however this is NOT recommended for a real installation. A P2 kit is available from GE Fanuc as part number IC697ACC715. This kit contains hardware necessary to mount a P2 backplane, which must be purchased from another source. The P2 backplane would only need to be of sufficient length to support this board, unless additional third party modules in the system also require P2.
- Due to the power consumption noted above, forced air cooling is strongly recommended for an industrial environment. The GE Fanuc Series 90-70 Rack Fan Assembly IC697ACC721 or IC697ACC724 could be used. In a lab environment, forced air cooling may not be required. If in doubt, temperature measurements should be made, and compared with VMIC's specifications.
- The ribbon cables which are used as the link transmission media may not be suitable for lengthy cable runs in an industrial environment. VMIC should be consulted if this is a problem.
- Many of the components are on sockets, including a crystal oscillator. It is possible that these components could come loose in a high vibration environment. This board is not recommended for a high vibration environment. Also, be sure to check that all components are seated before plugging in the boards.
- The board includes the ability to interrupt its local CPU when data is received from one of the other racks. This capability must be disabled with the present versions of the Series 90-70. Future versions of the Series 90-70 may allow interrupts of this type to be used. The board is useful even without this function.

This function would still be usable in a standard VME rack with a non Series 90-70 master.

- Discipline is required by each of the masters to ensure that they do not write to the same memory areas as the other masters (at least not at the same time). One approach is to allow all the masters to read the entire memory, but restrict (in local CPU software) write access for each master to a different area of the memory.
- If modification of a common *data base* by multiple masters is required, a mechanism must be set up in master firmware to ensure that modification of a data byte is not attempted simultaneously by more than one master.
- Extensive compatibility testing, quality testing, and so forth, was not done on this board by GE Fanuc. Although the board appears to work properly in the application described here, this does not guarantee that it will operate in all environments, or in all applications.

## High Speed Inter-Rack Communications Using Reflective Memory

---

### SETUP

The test that was conducted consisted of connecting two Series 90-70 systems together with the 5550 cards, and transmitting data in both directions. In CPU 0, data was read from the reflective memory, incremented, then passed to CPU 1. In CPU 1, the data was read from the reflective memory, then written back to CPU 0.

The two 5550 cards were both mapped at the CPUs VME address 100,000H, and were accessed with AM code 39H. It is not required, however, that all cards on the link have the same base address. The cards could be mapped to different address spaces in each CPU. When the master accesses the board, it is looking for data at an address relative to the base address of the board, not at any absolute address.

For example, if card A is mapped at 100,000H and card B is mapped at 200,000H, then data written to address 100,100H in card A can be read in card B at 200,100H.

The jumpers on both cards were set identically, except for the node ID jumper.

### JUMPERS

J12,J13    **IN**     full speed link  
 J11       **OUT**    Extended addressing disabled  
 J10       **IN**     Accepts both non-privileged and supervisory AM codes

J9         **IN/OUT,IN,IN,IN**  
 (top to bottom), sets the node address at 0 or 1, IN is address 0, OUT is address 1 for the Least Significant bit.  
**OUT,OUT,IN,IN** (top to bottom) -- sets the maximum node number at 3

(Note: The link should run slightly faster if the maximum node was set to 1 instead of 3).

J8         **IN,IN,OUT,IN,IN,IN,IN,IN**  
 (out is the A20 bit, which will set the start address to 100,000H in the CPUs VME address space).

J7,J6,J5,J4,J3,J2,J1 **ALL IN** (factory set for amount of on-board memory) .

The SIP resistor termination networks were left in for both cards, but should be removed for *middle* units if more than two units are connected. When more than two units are connected, an additional *vampire* connector is also used (VMIC part number 999-064).

Additional information regarding VME integration into the Series 90-70 is available in GFK-0448 (this manual). Additional information from VMIC regarding the 5550 may be obtained by calling Steve May - VMIC at 205-880-0444.

The information used for this setup was obtained from the 5550 instruction manual dated March 1991.

R. H. Matthews  
 Program Manager

**GE Fanuc Automation North America, Inc., Charlottesville, Virginia**

## High Speed Inter-Rack Communications Using Reflective Memory

---

### PHYSICAL CONFIGURATION

PS	1	2	3	4	5	6	7	8	9
RACK 0									
PROGRAMMED CONFIGURATION									
PWR710	CPU 771 #0	BEM 713	FOREIGN						
55W		XMTR	VME						
	64 KB		5550 Node 0						

2 - VMIC cables part --->  
number 000-64-010

PS	1	2	3	4	5	6	7	8	9
RACK 0									
PROGRAMMED CONFIGURATION									
PWR710	CPU 731 #1	BEM 713	FOREIGN						
55W		XMTR	VME						
			5550 Node 1						

## High Speed Inter-Rack Communications Using Reflective Memory

THE PROGRAM IN CPU #0

This program writes 0 to address 100005H on the first scan, this turns off the FAIL LED. This is normal operating procedure for the board. Then data is read from the 5550 at address 100100H, the data is incremented, then it is written to the 5550 at address 100200H. Although a feedback bit is available to determine if the transmit FIFO is empty, this bit was not used in this program.

```
[ START OF LD PROGRAM VMI5550 ]          (*          *)
[ VARIABLE DECLARATIONS ]
[ PROGRAM BLOCK DECLARATIONS ]
[ INTERRUPTS ]
[ START OF PROGRAM LOGIC ]

<< RUNG 5 >>
FST SCN          +-----+
+---]7[-----+ VME +-
                | WRT |
                | BYTE|
          CONST +-+IN |
          0000 | LEN  |
                |00001|
          CONST +-+AM |
          0039 |     |
                |     |
          CONST +-+ADR|
          00100005 +-----+

<< RUNG 6 >>
FST SCN          +-----+
+---]7[-----+ VME +------+ ADD +-
                | RD  |
                | BYTE|
          CONST +-+AM |
          0039 | LEN  |
                |00002|
          CONST +-+ADR Q+-%R00001
          00100100 +-----+
                                CONST +-+I1 Q+-%R00010
                                +0000000001 |
                                |
                                %R00001+-+I2 |
                                +-----+

<< RUNG 7 >>
FST SCN          +-----+
+---]7[-----+ VME +-
                | WRT |
                | BYTE|
          %R00010+-+IN |
                | LEN  |
                |00002|
          CONST +-+AM |
          0039 |     |
                |     |
          CONST +-+ADR|
          00100200 +-----+

[ END OF PROGRAM LOGIC ]
```

## High Speed Inter-Rack Communications Using Reflective Memory

---

THE PROGRAM IN CPU #1

On the first scan, the FAIL LED is reset by writing 0 to the 5550 address 100005H. Also, the data at 100100H is set to 0. On later scans, data from the other CPU is read at 100200H, then written back to the other CPU at 100100H. Although a feedback bit is available to determine whether or not the transmit FIFO is empty, this bit was not used in this program.

```

[ START OF LD PROGRAM VMI5551 ]          (*)
[ VARIABLE DECLARATIONS ]
[ PROGRAM BLOCK DECLARATIONS ]
[ INTERRUPTS ]
[ START OF PROGRAM LOGIC ]

<< RUNG 5 >>

|FST_SCN          +-----+
+---] [-----+ VME +-
          | WRT |
          | BYT |
          |-----|
          |CONST --+IN
          | 0000 | LEN |
          |-----|
          | 00001 |
          |CONST --+AM
          | 0039 |
          |-----|
          |CONST --+ADR
          | 00100005 +-----+

<< RUNG 6 >>

|FST_SCN          +-----+
+---] [-----+ VME +-
          | WRT |
          | BYT |
          |-----|
          |CONST --+IN
          | 0000 | LEN |
          |-----|
          | 00002 |
          |CONST --+AM
          | 0039 |
          |-----|
          |CONST --+ADR
          | 00100100 +-----+

<< RUNG 7 >>

|FST_SCN +-----+
+---] [---+MOVE +-
          | INT |
          |-----|
          |CONST --+IN Q+-%R00001
          | +00000 | LEN |
          |-----|
          | 00002 |
          +-----+

```



## High Speed Inter-Rack Communications Using Reflective Memory

---

```

| << RUNG 8 >>
| FST SCN          +-----+
+---]7[-----+ VME +-
|                 | RD   |
|                 | BYTE |
|   CONST --+AM   |
|     0039 | LEN  |
|         |00002 |
|   CONST --+ADR Q+-%R00001
| 00100200 +-----+

| << RUNG 9 >>
| FST SCN          +-----+
+---]7[-----+ VME +-
|                 | WRT  |
|                 | BYTE |
| %R00001--+IN   |
|         | LEN  |
|   CONST --+AM  |
|     0039 |
|
|   CONST --+ADR |
| 00100100 +-----+

| [   END OF PROGRAM LOGIC   ]

```



Number: H-12-91-35

To: 1, 2A, 3, 4, 8, 10, 11, 12

## Integration of a 68030 CPU with OS-9™ into the Series 90™ -70 PLC

### 1. Overview

Adding a foreign CPU to a Series 90-70 PLC is an excellent way to provide additional processing power, add an additional operator interface platform, or incorporate a high-level process controller to the system. A real-time operating system such as OS-9 is ideally suited for such an application. OS-9 is a high performance multi-tasking, ROMable operating system for Motorola 680x0 microprocessors. OS-9 provides a complete software development environment including a file system, editors and compilers in a UNIX-like environment.

Several customers have already written applications for OS-9, which are running on non-PLC platforms. By integrating a 68030 CPU with OS-9 into the Series 90-70 PLC, customers with OS-9 experience and/or canned applications can now take advantage of the industrial I/O provided by the Series 90-70 PLC. Users who have traditionally used OS-9 (quite often in conjunction with other VME platforms) may find the ability to interface to true industrial I/O in the Series 90-70 PLC particularly appealing.

The application example which follows describes the integration of a 68030 based module, with OS-9 into the Series 90-70 PLC system.

### 1.1 The Hardware Platform

The Matrix CPU330 is a high performance 68030 based CPU which provides a fast, extended temperature platform for OS-9 applications. Options are available to run at speeds up to 33 Mhz with up to 8 Mbytes of on-board dynamic ram. It provides a variety of real-time controller functions, and includes a Dbus-68 daughterboard interface with many available options.

Matrix is a participant in the GE Fanuc *Recommended VME Vendor* program, and has developed a custom CPU330 package specifically for use in the Series 90-70 PLC. The part number for this custom version is GE-CPU331-N-2. This part number includes the standard extended temperature CPU330 board with 1 Mbyte of RAM memory, custom OS-9 software, a 25 MHZ clock, and documentation specifically for use in the Series 90-70 PLC.

### 1.2 The Application

This application note demonstrates the CPU330 being used as both a VME slave and VME master in a Series 90-70 PLC system. No attempt has been made to use the complete set of hardware functionality of the CPU330 board; rather, an easy to understand application was developed primarily to demonstrate the successful integration of the CPU330 board and OS-9 into a Series 90-70 PLC system and provide a framework for more complex applications.

™ OS-9 is a trademark of Microware Systems Corporation.

™ Series 90 is a trademark of GE Fanuc Automation North America, Inc.

## Integration of a 68030 CPU with OS-9 into the Series 90-70 PLC

---

To demonstrate the mastership capability of the Matrix CPU board in the Series 90-70 system, a XYCOM XVME-428 8-port serial card was included in the setup. It not only provides dual port memory for the Matrix CPU to access, but also demonstrates a realistic application in conjunction with the Matrix CPU330 as a smart bar code reader. The CPU330 is programmable in C, which is provided with the *Professional OS-9* package supplied by Matrix. Version 3.2 was used to develop the code shown at the end of this application bulletin.

Also included in the setup is a Matrix DSM module containing a 50 Mbyte hard disk and 3-1/2 inch floppy disk drive. The DSM module contains the OS-9 system software for the disk-based Professional OS-9 and application software. The CPU330 and DSM communicate across the VME backplane. Keep in mind that the DSM is not needed to run the application. In this example, the CPU330 was used as the development environment, as well as the run time platform. The DSM was required only for development of the application program. A program could be developed on a totally different platform, then put into ROM or downloaded for execution on the CPU330.

### 2. Setup

The setup for this demonstration consists of the following:

- Series 90-70 9 slot rack
- 100 Watt power supply (The Matrix CPU330, DSM and XYCOM 428 all require 12V provided by the 100 Watt power supply).
- SLOT 1: Series 90-70 CPU772 with expansion memory daughterboard. The CPU used must have multiple master support. This will be explained further below. The CPU772 is connected to a Workmaster II through a serial cable. The Workmaster II was used to develop the 90-70 CPU ladder program.
- SLOT 2: Matrix GE-CPU331-N-2 with 1 Mbyte DRAM, 25 MHz - 68030, and two Serial ports. Professional GE-OS9 EPROMs installed. The CPU330 is configured to respond to 400000h - 4FFFFFFh in standard address space (AM Codes 39h or 3Dh).
- SLOT 3: Matrix GE-DSM-SF-FFF-050 with 1Mb 3.5I floppy disk drive and 50 Mb hard drive with controller. The DSM is configured to respond to 5000h - 507Fh in short address space (AM Codes 29h or 2Dh).
- SLOT 4: XYCOM XVME-428 Intelligent asynchronous serial communication module. The XVME-428 is, configured as a slave only, responding to 3800h - 3BFFh in short address space (AM Codes 29h and 2Dh).

RACK 0									
PS	1	2	3	4	5	6	7	8	9
P R O G R A M M E D C O N F I G U R A T I O N									
PWR711	CPU 772	FOREIGN	FOREIGN	FOREIGN					
100W	FLOAT 512 KB	VME	VME	VME					

## Note

A separate application note for the XVME-420/428 in a 90-70 environment has been published, if you would like additional information, contact GE Fanuc).

Please refer to GE Fanuc publication GFK-0448 (this manual) for additional information regarding integration of 3rd party VME modules into the Series 90-70 PLC environment.

## 2.1 Setup Notes

1. A Standard EIA-232 cable is connected between Serial Port B of CPU330 front panel and a VT100 terminal set for 9600 baud, no parity. This terminal is used as the CPU330 system console.
2. A serial cable assembly number XVME-930, available from XYCOM is connected between JK1 on the XVME-428 front panel and a VT100 terminal set for 9600 baud, no parity. Of the four D-connectors from the cable assembly, the one corresponding to serial port 0 is used. This VT100 is used for data entry into the XVME-428 board and can be replaced by any serial device such as a bar code reader (the OS-9 program, written in C, would need to be modified to accommodate the particular protocol of the bar code reader).
3. The Matrix DSM uses interrupt request 4 to communicate to the CPU330 board. Special backplane jumpers must be installed in the slots occupied by the CPU330 and the DSM to handle this interrupt. In this demonstration, the jumpers for IRQ4 at slot 2 (JP5) and slot 3 (JP 9) must be installed.
4. Since multiple VME master capability is demonstrated in this application note, a multiple-master Series 90-70 CPU is required. Multiple-master capability has been phased into Series 90-70 CPU models. Please contact GE Fanuc for details on which CPU revisions support multiple VME masters.
5. The CPU330, DSM and XVME-428 in this application all require " 12 VDC, therefore the 100 Watt power supply is needed.
6. A minor mechanical incompatibility problem exists between the Matrix Dbus-68 daughterboards and a standard Series 90-70 PLC rack. None of these daughterboards were used in this application. If you would like to use one of these Dbus-68 daughterboards, you will have to use a GE Fanuc Integrator rack (IC697CHS782/783) instead of the standard 9 slot rack.
7. GE Fanuc Series 90-70 products require only convection cooling when operating in a 0 - 60 degrees Celsius environment. Both the CPU330 and XVME-428 will also operate in this environment with convection cooling only. The DSM module however, is only rated at 4 - 45 degrees Celsius and would require fans if operating outside this range. This is not normally a problem since the DSM is typically only used for development (most likely in a controlled environment) and can be removed from many target systems.

## 2.2 Matrix GE-CPU330 Configuration

The Matrix GE-CPU330 is a standard MD-CPU330 shipped from the factory with jumpers already configured for operation in a Series 90-70 PLC and the special GE-OS9 firmware installed. Please verify that the jumpers are properly installed as described below before applying power to the system. A brief discussion of each jumper setting follows - refer to the MD-CPU330 User's Manual for more information:

SystemController - Jumpers J7, J11:	Disable system controller functions by removing J7 and J11. There can be only one <b>slot one</b> controller in the system, and this <b>MUST</b> be the Series 90-70 CPU.
EPROM Size - Jumper J4:	This jumper is set by the factory to match the EPROMs installed. Do not modify the factory setting.
Reset/AbortSwitchEnable - Jumper J5:	This jumper should be configured to disable the Reset/Abort switch by removing J5. Using the switch to reset the CPU330 causes SYSFAIL to be activated, thus forcing all Series 90-70 output boards to their default state. Disabling the switch prevents this from happening. The preferred method to reset the CPU330 is to power cycle the entire system.

VMEbusRequest Level - Jumpers J8, J9, J10:	These jumpers are shipped with Bus Request level 3 set. The Series 90-70 PLC has a fixed priority arbiter with BR1 as the highest priority followed by BR0, BR3 and BR2. Foreign VME masters are only allowed to use BR3 and BR2.
Serial Port A Flow Control - Jumper J3:	This is configured for RTS/CTS flow control as shipped from the factory. It should be set to match the user's Port A serial device.
Serial Port A Interface Selection	SPA-330-422 is installed in the DTE configuration as shipped from the factory. It depends on Port A option ordered. Set orientation to select DCE or DTE according to the user's Port A needs.

The standard professional/industrial OS-9 EPROMS were specially modified by Matrix for use in a Series 90-70 PLC. Make sure you specify these EPROMs when ordering OS-9 from Matrix. When you order the GE-CPU330, the special EPROMs come already installed.

The special GE Fanuc modifications made to the OS-9 EPROMs are as follows:

- The CPU330 VME slave address is at 0400000h. The standard CPU330 slave address was changed to avoid potential conflicts with *reserved* Series 90-70 PLC addresses.
- A special 4K of memory is reserved for data transfers to/from the Series 90-70 PLC. The use of this memory is completely user defined. This memory starts at offset 0400h from the base address of the board.
- VME IRQ4 is the only VME interrupt enabled. Use of IRQ5-7 is not allowed by foreign VME boards.
- The professional OS-9 EPROMs will look for the DSM module at address 5000h in short address space. The standard DSM slave address was changed to avoid potential conflicts with Series 90-70 PLC *reserved* addresses.

### 2.3 The Matrix DSM Configuration

THE GE-DSM is the standard DSM shipped from the factory with jumpers already configured for operation in a Series 90-70 PLC. Please verify that the jumpers are properly installed as described below before applying power to the system. A brief discussion of each jumper setting follows - refer to the MD-SCSIFLP User's Manual for more information:

Base Address - Jumpers J4:	Set jumpers for base address of 5000h. The jumpers <b>MUST</b> be set for this address in order for the GE-CPU330 to find the DSM.
AM Code Response - Jumper J6:	Remove J6 to allow both supervisory and non-privileged access (Am codes 29h and 2Dh). Will work either way.
Interrupt Request Level - J3:	Set for Interrupt Request level 4. <b>MUST</b> be set for this level for the GE-CPU330 to recognize the interrupt.

---

VMEbus Request Level - Jumper J5:	These jumpers are shipped with Bus Request level 3 set. The Series 90-70 PLC has a fixed priority arbiter with BR1 as the highest priority followed by BR0, BR3 and BR2. Foreign VME masters are only allowed to use BR3 and BR2.
Bus Grant Daisy-Chain - Jumpers J7:	Must be set to correspond with Bus request level which in this case is Bus Grant 3 Daisy-chain.
SCSI Termination Power - Jumper J1:	Remove J1 for no termination power.
High Density Drive - Jumper J2:	Will be set by factory to correspond to DSM model ordered.

## 2.4 XYCOM XVME-428 Configuration

The XVME-428 Jumper settings were modified slightly from their factory defaults. A brief discussion of each follows - refer to the XVME-428 User's Manual for more information:

Base address - Jumpers J4, J5, J7, J8:	Set jumpers for base address at 3800h. Set J4=IN; J5, J7, J8=OUT.
Address modifier - Jumper J3:	Install J3 for recognition in both supervisory and non-privileged short I/O space (AM Codes 29h and 2Dh).
Bus Request level - Jumpers J1, J2, J6:	Use factory default of Bus Request level 3. This is not used since XVME-428 will not be used as a bus master in this application.
Memory range select - Jumpers J9-J14:	These are set by the factory to match the memory installed in the board. Do not modify the factory settings.
P2 Power - Jumpers J17, J18, J19:	Keep all jumpers in B position - no power supplied to P2 connector.

## 3. Application Programs

### 3.1 Overview

In this application, the Matrix CPU330 board will collect data from both the XYCOM serial card and the Series 90-70 CPU, sort it and display the data in a simple bar graph. The data consists of three digit ASCII numbers which will be sorted and displayed by ranges (that is, 100-200, 500-900, and so forth).

The Series 90-70 CPU will periodically write data to the dual port ram on the Matrix CPU and set a flag indicating that data is available. The Matrix CPU330 polls this flag and when it is set, will read the data and reset the flag. This demonstrates use of the CPU330 as a VME slave.

The Matrix board collects data from the XVME-428 board by commanding it to read three characters. The Matrix CPU then polls the read complete flag. When the read command is complete this flag is set and the Matrix CPU will read the data from the XVME-428 dual port ram. The three digit data is entered at the VT100 keyboard but could come from any serial device such as a bar code reader (the three digit data could represent a three digit bar code for instance). When the three digit data is read by the Matrix CPU, it will echo the data back to the XVME-428 by issuing a write command. The data will then appear on the VT100 terminal. All commands are written to the XYCOM XVME-428 board by the CPU330. This demonstrates use of the CPU330 as a VME master.

Data collected from the Series 90-70 CPU and XVME-428 is checked, sorted and displayed on the Matrix system console (VT100) in bar graph format. When invalid data is detected, an error flag will be set in the Matrix dual port ram to inform the Series 90-70 CPU of an error (the CPU does nothing with this error).

The C program on the CPU330, and the ladder logic in the Series 90-70 CPU are described later in this document.

### 3.1.1 Controlling the XVME-428 Serial Card

The XVME-428 power up default settings are used for this application:

- 8bits/character, 1 stop bit, no parity
- 9600 baud
- no line control
- incoming characters not echoed
- record I/O mode (transmit/receive strings of characters)
- no request acknowledge interrupt

Commanding the XVME-428 to execute a transmit/receive is a three step process. The first step is to write a command block to the XVME-428 dual port ram. This command block will tell the XVME- 428 what to do and also contains an area for the transmit or receive data (only if 6 bytes or less of data). The second step is to write a pointer to the command block into the Command block pointer for channel 0. This tells the XVME-428 where the command block is located. The third step is to write to the I/O request register for channel 0, initiating command execution.

For simplicity in this application, the Response Flag (byte 6 of the command block) will be polled to determine when the operation has completed. The XVME-428 is also capable of generating an interrupt to the CPU330 upon command completion. Using this method instead would cut down on bus traffic and possibly improve system performance.

The XVME-428 addresses are constructed as follows:

$$\begin{array}{ll}
 0\text{xff}00000 & \text{access to VME short address space from CPU330} \\
 + 0\text{x}00003800 & \text{base address of XYCOM 428 board} \\
 + 0\text{x}00000092 & \text{XYCOM 428 pointer register offset} \\
 \hline
 = 0\text{xff}03892 & \text{address of XYCOM 428 pointer register}
 \end{array}$$

For more information on programming the XVME-428 please refer to the XYCOM XVME-428 Intelligent Asynchronous Serial Communication Module Users Manual, and the XVME420/428 application note which was previously published.

### 3.1.2 Series 90-70 CPU and Matrix CPU330 Communications

The Matrix board is used strictly as a slave when communicating to the Series 90-70 CPU. Data is written directly by the Series 90-70 CPU into the Matrix dual port ram. To make this type of communication easy to use, Matrix has reserved a 4K block of dual port memory for transfers between the Series 90-70 PLC and the CPU330. This block of memory does not need to be allocated. It is hidden from OS-9 and therefore will never be used by the operating system or allocated to any application programs. This 4K block of memory is located at offset 0400h from the base address of the CPU330 and is only available on the special GE-OS9 firmware (prom set).

The use of this 4K block of memory is completely up to the user. If you need to use more than 4K bytes of memory for Series 90-70 PLC to Matrix CPU data transfers, have your OS-9 program execute a memory request and store a pointer to this newly allocated memory in the default 4K block. This will allow the PLC to find the extra memory block.

## 3.2 Matrix C Program Source Code

```

/* -----
MATAPP: This routine collects three digit ascii data from a
90-70 CPU and XYCOM serial card and displays the information in
bar graph format.
DDS      9-12-91
----- */

#include <stdio.h>

void blank_screen();
void title_page();
void overlay();
void cmd_428();
int poll_428();
void graph_xvme_data();
void graph_plc_data();
int verify_ascii_data();

#define XVME_CMD_ADDR 0xfff03a00
#define XVME_PTR_ADDR 0xfff03892
#define XVME_REQ_ADDR 0xfff03882
#define PLC_DATA_ADDR 0x0400
#define PLC_FLAG_ADDR 0x0410
#define PLC_ERROR_ADDR 0x0420

char *xvme_cmd_ptr = XVME_CMD_ADDR;
char *xvme_ptr_ptr = XVME_PTR_ADDR;
char *xvme_req_ptr = XVME_REQ_ADDR;
char *plc_data_ptr = PLC_DATA_ADDR;
int *plc_flag_ptr = PLC_FLAG_ADDR;
int *plc_error_ptr = PLC_ERROR_ADDR;

/* data counters */
int x0,x1,x2,x3,x4,x56789 = 0;
int p0,p1,p2,p345,p678,p9 = 0;

char xvme_rd_cmd[14] = {0,0x05,0xff,0xff,0,0,0xff,
                      0xff,0,0,0,0,0x03,0x03};
char xvme_wr_cmd[14] = {0,0x06,0xff,0xff,0,0,0xff,
                      0xff,0,0,0,0,0x04,0x04};
char xvme_clr_cmd[14] = {0,0x02,0,0,0,0,0,0,0,0,0,0,0,0};
char xvme_ptr_cmd[6] = {0,0x2d,0,0,0x3a,0};

main()
{
    blank_screen();
    title_page();          /* display title page */
    blank_screen();
    overlay();
    *plc_flag_ptr = 0;
    cmd_428(xvme_clr_cmd); /* command XYCOM 428 clear */
    while (poll_428() == 0) ; /* wait for cmd compl */
    cmd_428(xvme_rd_cmd); /* command XYCOM 428 read */
}

```



```

while(1) {
    if (poll_428() == 1) {
        /* When XYCOM 428 has data available, verify the
           data and plot it. If data is invalid, flag error.
           Echo data back by issuing a XYCOM 428 write
           command. When complete, command new data read. */

        if (verify_ascii_data(&xvme_cmd_ptr[14])) {
            graph_xvme_data();
        } else {
            *plc_error_ptr = 0xff;
        }
        *(xvme_cmd_ptr + 17) = '\n';
        cmd_428(xvme_wr_cmd);
        while (poll_428() == 0) ; /* wait write compl */
        cmd_428(xvme_rd_cmd); /* cmd XYCOM 428 read */
    }
    if (*plc_flag_ptr) {
        /* When PLC has data available, verify the data
           and plot it. If data is invalid, flag error. */

        if (verify_ascii_data(plc_data_ptr)) {
            graph_plc_data();
        } else {
            *plc_error_ptr = 0xff;
        }
        *plc_flag_ptr = 0;
    }
}

}

/* -----
BLANK_SCREEN: Clears the system terminal screen
----- */
void blank_screen()
{
    int lines;

    for (lines = 0; lines < 28; lines++) {
        putchar('\n');
    }
}

/* -----
TITLE_PAGE: Displays title page for 2 seconds.
----- */
void title_page()
{
    printf("  MATRIX CPU-330 with OS-9 APPLICATION NOTE\n\n");
    printf("  GE FANUC AUTOMATION, Charlottesville, VA\n\n");
    printf("  WRITTEN BY: Dan Schnittka\n");
    printf("\n\n\n\n\n\n\n\n\n\n");
    sleep(2);
}

```

```

/* -----
OVERLAY: Displays the bar graph overlay.
----- */
void overlay()
{
    printf("\033[H");
    printf("          XVME BAR CODE GRAPH\n");
    printf("          -----\n\n");
    printf("000-099 : \n");
    printf("100-199 : \n");
    printf("200-299 : \n");
    printf("300-399 : \n");
    printf("400-499 : \n");
    printf("500-999 : \n\n\n\n");
    printf("          PLC BAR CODE GRAPH\n");
    printf("          -----\n\n");
    printf("000-099 : \n");
    printf("100-199 : \n");
    printf("200-299 : \n");
    printf("300-599 : \n");
    printf("600-899 : \n");
    printf("900-999 : \n");
}

/* -----
CMD_428: Write command to XYCOM 428 serial port board. Pass in
pointer to command array.
----- */
void cmd_428()
char *data;
{
    int i;

    /* Write command to XVME 428 dual port ram */
    for (i=0; i<14; i++) {
        *(xvme_cmd_ptr + i) = data[i];
    }
    /* Write pointer to command in Command Block Pointer
       (channel 0) */
    for (i=0; i<6; i++) {
        *(xvme_ptr_ptr + i) = xvme_ptr_cmd[i];
    }
    /* Write channel 0 I/O request register to start command
       execution */
    *xvme_req_ptr = 0x01;
}

```

```

/* -----
POLL_428: Poll the XVME 428 for command complete. Return TRUE if
complete, FALSE otherwise.
----- */
int poll_428()
{
    /* Check response flag (byte 6 of command block) for command
    complete */
    if ( *(xvme_cmd_ptr + 6) == 0) {
        return(1);
    } else {
        return(0);
    }
}

/* -----
XVME_GRAPH_DATA: Produces bar graph of XVME 428 data after
sorting the data by value.
----- */
void xvme_graph_data()
{
    int i;

    /* Data is contained in command block starting at byte 14 */
    switch ( *(xvme_cmd_ptr + 14)) {

        case '0' :
            /* move cursor to correct row */
            printf("\033[4;12H");
            i = ++x0;
            break;
        case '1' :
            /* move cursor to correct row */
            printf("\033[5;12H");
            i = ++x1;
            break;
        case '2' :
            /* move cursor to correct row */
            printf("\033[6;12H");
            i = ++x2;
            break;
        case '3' :
            /* move cursor to correct row */
            printf("\033[7;12H");
            i = ++x3;
            break;
        case '4' :
            /* move cursor to correct row */
            printf("\033[8;12H");
            i = ++x4;
            break;
        default :
            /* move cursor to correct row */
            printf("\033[9;12H");
            i = ++x56789;
            break;
    }
}

```

```

/* Prevent overwriting screen */
if (i>65) i=65;

/* Write bar for this row, 1 X per count */
for ( ; i>0; i--) {
    printf("X");
}
printf("\n");
}

/* -----
PLC_GRAPH_DATA: Produces bar graph of 90-70 CPU data after
sorting the data by value.
----- */
void plc_graph_data()
{
    int i;

    /* Data is contained in command block starting at byte 14 */
    switch (*plc_data_ptr) {

        case '0' :
            /* move cursor to correct row */
            printf("\033[16;12H");
            i = ++p0;
            break;

        case '1' :
            /* move cursor to correct row */
            printf("\033[17;12H");
            i = ++p1;
            break;

        case '2' :
            /* move cursor to correct row */
            printf("\033[18;12H");
            i = ++p2;
            break;

        case '3' :
        case '4' :
        case '5' :
            /* move cursor to correct row */
            printf("\033[19;12H");
            i = ++p345;
            break;

        case '6' :
        case '7' :
        case '8' :
            /* move cursor to correct row */
            printf("\033[20;12H");
            i = ++p678;
            break;

        default :
            /* move cursor to correct row */
            printf("\033[21;12H");
            i = ++p9;
            break;
    }
}

```

```
/* Prevent overwriting screen */
if (i>65) i=65;

/* Write bar for this row, 1 X per count */
for ( ; i>0; i--) {
    printf("X");
}
printf("\n");
}

/* -----
VERIFY_ASCII_DATA: Verifies that 3 digit data are all valid ascii
numbers. Pass in pointer to 3 digit data. Returns TRUE if data
valid, FALSE otherwise.
----- */
int verify_ascii_data()

char *data_ptr;
{
    /* Check all three digits for valid ascii numeral */
    if ( (data_ptr[0] >= '0') && (data_ptr[0] <= '9')) {
        if ( (data_ptr[1] >= '0') && (data_ptr[1] <= '9')) {
            if ((data_ptr[2] >= '0') && (data_ptr[2] <= '9')){
                return(1);
            }
        }
    }
    return(0);
}
```

### 3.3 90-70 Ladder Logic Description

```
[ START OF LD PROGRAM MATAPP ]
[ VARIABLE DECLARATIONS ]
[ PROGRAM BLOCK DECLARATIONS ]
[ INTERRUPTS ]
[ START OF PROGRAM LOGIC ]
```

```
<< RUNG 5 >>
```

```
FST_SCN +-----+
+---] [---+BLKMV+-
      |      |
      |      | WORD
      |      |
CONST --+IN1 Q+--%Q00001
      |      |
      |      | 3031
      |      |
CONST --+IN2
      |      |
      |      | 3233
      |      |
CONST --+IN3
      |      |
      |      | 3334
      |      |
CONST --+IN4
      |      |
      |      | 3536
      |      |
CONST --+IN5
      |      |
      |      | 3738
      |      |
CONST --+IN6
      |      |
      |      | 3935
      |      |
CONST --+IN7
      |      |
      |      | 3331 +-----+
```

```
<< RUNG 6 >>
```

```
+-----+
+-----+ ROL +-----+
+-----+ WORD +-----+
+-----+
%Q00001--+IN Q+--%Q00001
      |      |
      |      | LEN
      |      | 00007
CONST --+N
      |      |
      |      | 00008 +-----+
```



*Appendix*

*H*

*Related VME Products*

---

---

This appendix is a partial listing of VME products which have been used successfully with Series 90-70 PLC systems.



FULLY QUALIFIED VME PRODUCTS

MANUFACTURER	MODEL	FUNCTION	GE FANUC CONTACT	STATUS
RADISYS 19545 N.W VON NEUMANN DR BEAVERTON, OR 97006 (503) 690-1229	EPC-1	IBM AT COMPATIBLE 386 EGA	JOE CIERI	QUALIFIED, App note is available. Rep agreement.
ITRAN 670 N Commercial St. Manchester, NH 03101 603-669-6332	DS-10 FS-10	Dimension Sensor Feature Sensor (vision)	Mike Smith Bob Herbert Dick Matthews	QUALIFIED, Notes 4,5. App note avail. Rep agreement.
DELTA TAU 21119 OSBORNE ST. CANOGA PARK, CA. 91304 (818) 998-2095	SMCC-VME	2 AXIS MOTION CONTROL	BOB HERBERT KENT DAVIS	QUALIFIED App note is available.
DELTA TAU	PMAC	4/8 AXIS MOTION CONTROLLER	KENT DAVIS BOB HERBERT	QUALIFIED. App note avail.
VMIC 12090 S. MEMORIAL PKWAY HUNTSVILLE ALABAMA, 35803 (205) 880-0444	VMIVME-3230	8 CHANNEL THERMOCOUPLE	JOE CIERI	QUALIFIED. App note is available. Notes 1,2,3
VMIC	VMIVME-3220	8 CHANNEL RTD/STRAIN GAUGE	JOE CIERI	Notes 1,2,3

Note 1 : This board has not been tested to the manufacturer's vibration specifications.  
 Note 2 : The board manufacturer recommends the use of fans for this product.  
 Note 3 : This product does not have electrical isolation between the user connections and the 90-70 backplane.  
 Note 4 : No published vibration or shock specifications.  
 Note 5 : Product is rated at 45 degrees C without forced air.

VME Contacts in addition to those listed above -- BILL FOUNTAIN 8\*277-5771, Dick Matthews 8\*277-5704

VME PRODUCTS WITH PENDING QUALIFICATION

MATRIX	MULTIPLE ITEMS -- SEE VENDOR PAGE	
ITRAN	PS-10	Position Sensor
		Mike Smith Jill Willson Dick Matthews
		CHVL 8*277-5056 CHVL 8*277-5747 CHVL 8*277-5704
		QUALIFICATION IN PROGRESS.
DELTA COMPUTER	VMC 186/40	TEMPOSONICS MOTION CONTROLLER
11719 NE 95TH ST, Suite D		BILL MADISON
VANCOUVER WA. 98682		Dick Matthews
(206) 254-8688		8*446-7130 8*277-5704
Dave Lee		QUALIFICATION UNDERWAY.

-----  
 NOTE: THE FOLLOWING PRODUCTS ARE PENDING QUALIFICATION AS A BOARD SET. THEY ALLOW GENIUS I/O TO BE CONNECTED TO A 90-70 RACK (no 90-70 CPU) WITH A RESIDENT AB PLC5/VME PROCESSOR. IT SHOULD BE NOTED THAT THIS BOARD HAS BEEN SUCCESSFULLY USED WITH THE AB PLC5/VME PRODUCT AVAILABLE AT THE TIME THE TEST WAS CONDUCTED. THE PLC5/VME ITSELF WAS NOT EVALUATED AS PART OF THE TESTING.

Although it is possible to use the GSM-100 in conjunction with a 90-70 CPU, associated interface logic is complex, and use of the standard GE Fanuc Genius bus controller is preferred.

The GE Fanuc contact below should be consulted before using this module.

Cimple Products  
 P.O. Box 1038  
 Cary, NC. 27512-1038  
 919-233-9349

Joe Cieri      8\*277-5720

-----

NOTE: ITEMS ON THIS PAGE HAVE BEEN INTEGRATED INTO THE 90-70 IN AT LEAST ONE APPLICATION; HOWEVER SUITABILITY MUST BE INDIVIDUALLY EVALUATED FOR OTHER APPLICATIONS.

VME Contacts in addition to those listed above -- BILL FOUNTAIN 8\*277-5771, Dick Matthews 8\*277-5704

December 13, 1991

VME VENDORS WITH SIGNIFICANT 90-70 EXPERIENCE

The "broad line" VME board vendors listed below have all successfully integrated at least one of their modules into a 90-70 system. Modules claimed by the vendor to be successfully integrated are also listed. GE Fanuc does not make any guarantees with regard to the applicability of these modules, or their integratability into the 90-70 system. Those items with which GE Fanuc has had some actual experience are noted in the comments. These vendors should be able to provide application assistance with regard to any of their products. These vendors have a 90-70 at their facilities.

VENDOR	PART NUMBER	DESCRIPTION	COMMENTS
XYCOM Dave Garrison 313-429-4971	XVME-420	4 port intelligent serial port card	GE Fanuc has verified
	XVME-428	8 port intelligent serial port card	GE Fanuc has verified
	XVME-230	High speed counter	GE Fanuc has verified
	XVME-100	SRAM memory	Standard address space only
	XVME-110	SRAM memory	
	XVME-686	386 based CPU	
	XVME-955	Floppy / Hard disk	
	XVME-602	68020 based CPU	
	XVME-951	XT expansion module (with 686)	Uses 90-70 addresses from rack 4, slot 2 and requires 6U adaptor
	XVME-684	486 DX AT computer	GE Fanuc appnote note available
VMIC Steve May 205-880-0444	VMIVME-3220	Thermocouple	QUALIFIED
	VMIVME-3230	RTD	QUALIFIED
	VMIVME-3114	Analog, 12 bit, 8 channel, 125khz	Call Joe Cieri - 8*277-5720
	VMEVME-3115	Analog, 12 bit, 4 channel, 2 MHZ	IN DEVELOPMENT - call VMIC
	VMEVMI-5550	Reflective memory - rack to rack	IN DEVELOPMENT - call VMIC
	GE-CPU331-N-2	68030 CPU board, OS-9, 1MB	APPLICATION TEST SUCCESSFUL
	GE-DSM-SF-FFF-050	Hard/floppy disk 50MB, 1.44M	Call Dick Matthews 8*277-5704
	GE-P/SIO2-22T6	Serial port daughter board for 331	for the status and/or information.
	DB-ETH6F	Ethernet daughter board for 331	An app note will be available.
	GE-CPUE101-N2NN	CPU with Ethernet	Successful applications have been written.
MATRIX 919-231-8000 (Chris Busch)	GE-CPU-321	68020 CPU / OS-9	Integrated successfully at CHVL, but requires (legally) a P2 backplane to supply adequate current. We ran it with only P1. Will not be qualified since the 331 above is a better choice.
	GE-CPUE101-N2NN	CPU with Ethernet	

There are special part numbers for the Matrix boards which customize the boards for use in the 90-70. Be sure to mention this when ordering. Matrix has other 68000 based boards which are also under consideration for qualification.

HIGH INTEREST VME PRODUCTS WITH LIMITED INTEGRATION TESTING

MANUFACTURER	MODEL	FUNCTION	GE FANUC CONTACT	COMMENTS
SUTHERLAND-SCHULTZ LTD Brian Thomson/Ian Suttie 519-743-4123	5136-AB-VME VME TO AB DATA HIGHWAY	Mike Smith 8*277-5056	App note is available.	
XYCOM Dave Garrison 313-429-4921 X365	XVME-230 HIGH SPEED COUNTER	Jeff Leonard 8*389-4951	Special order/mod required to disable SYSFAIL response.	
XYCOM Dave Garrison 313-429-4921 X365	XVME-420 4 PORT INTELLIGENT SERIAL PORT CARD	Dick Matthews Mike Smith 8*277-5704 8*277-5056	Special order/mod required to disable SYSFAIL response. APP note is available for BAR CODE applications.	

NOTE: ITEMS ON THIS LIST HAVE BEEN INTEGRATED INTO THE 90-70 IN AT LEAST ONE APPLICATION; HOWEVER SUITABILITY MUST BE INDIVIDUALLY EVALUATED FOR OTHER APPLICATIONS. MODULES ON THIS LIST HAVE NOT BEEN QUALIFIED AND, EXCEPT AS NOTED, ARE NOT UNDER CONSIDERATION FOR THE QUALIFICATION PROCESS.

VME Contacts in addition to those listed above -- BILL FOUNTAIN 8\*277-5771, Dick Matthews 8\*277-5704

December 13, 1991

OTHER VME PRODUCTS WITH LIMITED INTEGRATION TESTING

MANUFACTURER	MODEL	FUNCTION	GE FANUC CONTACT	COMMENTS
Nissho Bob Bauer 714-261-8811	N5280-T41XC1B-A0 N7210-T112BX-A0	386 SX AT COMPUTER 40 MB HD, 1.44 MB FD	Dick Matthews 8*277-5704	Turbine control, Compressors.
Allen-Bradley	PLC5/VME	AB CPU	Joe Cieri Mike Smith 8*277-5720 8*277-5056	APP NOTE AVAILABLE
MICRODIMENSIONS (216) 974-8070	VME-1000	HIGH SPEED DATA COLLECTION	JOE CIERI DAVE GEORGE 8*277-5720 8*766-6058	APP NOTE AVAILABLE
DATEL (508) 339-3000	DVME-602T	4 CHANNEL THERMOCOUPLE		PC BOARD PLATING. NOT AS EASY TO USE AS VME VMIVME3230.
IIC DATA DEVICE (516) 567-5600	BUS6522/23	MIL-STD-1553 BUS CNTRL		AEBG APPLICATION
RADISYS (503) 690-1229	EPC-3	IBM-AT COMPATIBLE 386SX VGA	Joe Cieri 8*277-5720	GE FANUC PLC LAB ALBANY CIMPPLICITY LAB (POSSIBLE FUTURE QUALIFICATION)
BIT-3 COMPUTER (612) 881-6955	403	VME-IBM PC/AT BUS INTERFACE Note: This module has limited usefulness. SNP provides a lower cost, well supported alternative for accessing and controlling PLC data from a PC/AT.		GE FANUC PLC LAB
BIT 3 COMPUTER CORP	412	VME-VME BLOCK MODE DMA ADAPTOR		LAB TEST
ASTROSYSTEMS, INC. (516) 328-1600	BVME-1020	RESOLVER/ENCODER INTERFACE	SPIROS GEORGIU 8*269-7160	LAB TEST
THEMIS COMPUTER (415)-734-0870	TSVME-206	RAM MEMORY WITH BATTERY BACKUP	Dick Matthews 8*277-5704	LAB TEST
PROSYST France 011-33-27-42-44-06	AIDIAG (90-70)	Chronogram display of I/O	Dick Matthews Vince Lytle 8*277-5704 8*277-5750	LAB TEST
FORCE	CPU-30	68030 BASED CPU	DAVE GEORGE 8*766-6058	Contact George before using.

NOTE: ITEMS ON THIS LIST HAVE BEEN INTEGRATED INTO THE 90-70 IN AT LEAST ONE APPLICATION; HOWEVER SUITABILITY MUST BE INDIVIDUALLY EVALUATED FOR OTHER APPLICATIONS. MODULES ON THIS LIST HAVE NOT BEEN QUALIFIED AND, EXCEPT AS NOTED, ARE NOT UNDER CONSIDERATION FOR THE QUALIFICATION PROCESS.

VME Contacts in addition to those listed above -- BILL FOUNTAIN 8\*277-5771, Dick Matthews 8\*277-5704

December 13, 1991

December 13, 1991

-----  
FULLY QUALIFIED VME PRODUCTS - WITH REP AGREEMENT

RADISYS           EPC-1           IBM AT COMPATIBLE 386 EGA  
ITRAN            DS-10          Vision Dimension Sensor  
ITRAN            FS-10          Vision Feature Sensor

FULLY QUALIFIED VME PRODUCTS - NO REP AGREEMENT

DELTA TAU        SMCC-VME       2 AXIS MOTION CONTROL  
DELTA TAU        VMCC           4/8 AXIS MOTION CONTROL  
VMIC            VMIVME-3230    8 CHANNEL THERMOCOUPLE  
VMIC            VMIVME-3220    8 CHANNEL RTD/STRAIN GAUGE

-----  
VME PRODUCTS WITH PENDING QUALIFICATION

QUALIFICATION OF THE FOLLOWING MODULES IS NOT COMPLETE. REMEMBER THAT UNTIL QUALIFICATION IS COMPLETE, FULL INTEROPERABILITY WITH THE 90-70 CANNOT BE ASSURED. THESE PRODUCTS HAVE RECEIVED LIMITED INTEGRATION TESTING, HOWEVER.

ITRAN            PS-10          Position Sensor  
DELTA COMPUTER   VMC 186/40     TELESONICS MOTION CONTROLLER  
IEP             GCM-100       AB PLC-5/VME to Genius Interface  
MATRIX          GSM-100       card set (pair)  
                MDCPU-330     68030 CPU and ACCESSORIES, OS-9

-----  
VME PRODUCTS WITH LIMITED INTEGRATION TESTING

NOTE: ITEMS ON THIS LIST HAVE BEEN INTEGRATED INTO THE 90-70 IN AT LEAST ONE APPLICATION; HOWEVER SUITABILITY MUST BE INDIVIDUALLY EVALUATED FOR OTHER APPLICATIONS. MODULES ON THIS LIST HAVE NOT BEEN QUALIFIED.

Allen-Bradley    PLC5/VME       AB CPU  
MICRODIMENSIONS VME-1000       HIGH SPEED DATA COLLECTION  
DATEL            DVME-602T      4 CHANNEL THERMOCOUPLE  
ILC DATA DEVICE BUS65522/23   MIL-STD-1553 BUS CNTNR  
RADISYS          EPC-3          IBM-AT COMPATIBLE 386SX VGA  
BIT-3 COMPUTER   403            VME-IBM PC/AT BUS INTERFACE  
BIT 3 COMPUTER   412            VME-VME BLOCK MODE  
ASTROSYSTEMS, INC. BVMC-1020     RESOLVER/ENCODER INTERFACE  
THEMIS COMPUTER   TSVME-206     RAM MEMORY WITH BATTERY BACKUP  
FORCE            CPU-30         68030 BASED CPU  
MATRIX          CPU320         68020 BASED CPU  
SUTHERLAND-SCHULTZ LTD 5136-AB-VME   AB I/O Scanner  
XYCOM            XVME-230       High speed counter  
                XVME-420       intelligent 4 port Serial card  
                XVME-428       intelligent 8 port serial card  
                XVME-686       386 based processor  
                XVME-955       Hard disk / floppy  
                XVME-620       68020 CPU  
                XVME-100       SRAM MEMORY  
                XVME-684       486 DX AT computer  
VMIC            VMIVME-3114     High speed analog  
                VMEVME-3115   Super high speed analog  
                VMEVMI-5550   Reflective memory - rack to rack 20  
                          Mbytes per second communications  
NISSHO          N5280-T41XC1B-A0 386 SX AT Computer  
                N7210-T112BX-A0 40 MB HD and 1.44 MB 3.5 inch FD  
PROSYST         AIDIAG (90-70) AI Diagnostic Chronograms

CONTACT BILL FOUNTAIN 8\*277-5771 or DICK MATTHEWS 8\*277-5704 FOR INFORMATION

## Numbers

3rd party VME interrupt support, 3-21

3U module, single-high, 2-3

6U module, double-high, 2-3

## A

Access types for AM codes, 3-1

ACFAIL signal, 1-4

Address allocation, 3rd party, 3-1

Address allocation, Series 90-70, 3-2

Address length for AM codes, 3-1

Addressing, slot, F-9

AM codes, 3-1

    Short nonprivileged, 3-1

    Short supervisory, 3-1

    Standard nonprivileged, 3-1

AM codes, access types and address length, 3-1

Application examples, G-1

Arbiter, 1-3

Arbitration bus, 1-3

## B

Backplane voltage isolation, 2-3

Backplane, description of, 1-2

Backplane, J2, 2-4

Backplanes, J1 and J2, 2-4

Bus extender, 2-7

Bus master modules, 2-6

Bus slave modules, 2-7

Bus timer function, 1-3

Bus width, 2-7

Bus width compatibility, 3-5

Bus, data transfer, 1-3

Bus, utility, 1-3

Byte significance convention

    Intel, 5-1

    Motorola, 5-1

Byte swapping, example of, 5-1

## C

C.1, VMEbus specification, 2-1

Cable, power supply extension, F-9

Categorization, candidate modules, 2-6

Checklist, compatibility, D-1

CIMPLICITY Control, 3-21

Clock function, 3-5

Codes, AM, 3-1

Communications, Genius I/O, 3-7

Compatibility checklist, D-1

Compatibility, bus width, 3-5

Configuration, VME, 3-8

Configuration mode, 3-11

    selecting the configuration mode for a VME module, 3-11

Configuration, interrupt (3rd party), 3-22, 3-23

Configuring a VME module, 3-10

Cooling with rack fan assembly, 1-4

Cooling, additional, F-11

Cooling, fans, 2-2

Cooling, rack, 4-1

CPU, interrupting, 3-21

Current, VME module, 2-2

## D

Data move functions

    VME\_CFG\_RD, 5-14

    VME\_CFG\_WRT, 5-16

Data sheet, VME integrator rack, F-1

Data transfer arbitration bus, 1-3

Data transfer bus, 1-3

Definition, VMEbus, 1-1

Dual-ported memory, 2-7

## E

Environmental considerations, list of, 2-1

Expansion racks, 3-4  
Extender, VMEbus, 2-7

## F

Fan assembly, rack, 1-4, 4-1, F-11  
Fans for cooling, 2-2  
Full mail mode, 3-15

## G

Genius I/O communications link, 3-7  
Grounding requirements, 4-1

## H

Handlers, interrupt, 1-3

## I

I/O configuration, VME, 3-8  
I/O scan mode, 3-19  
IEC 821 and 297, 1-1  
IEEE/ANSI STD 1014-1987, 1-1  
Installation, VME modules  
    cooling requirements, 4-1  
    grounding requirements, 4-1  
    location in rack, 4-1  
    rack standoffs, J2 backplane, 4-1  
Integration of 3rd party VME modules,  
    2-1  
Integrator rack, VME, 3-7, F-1  
International trade association, VITA, E-1  
Interrupt configuration (3rd party), 3-22,  
    3-23  
    configuration mode, 3-22  
    interrupt, 3-22  
    interrupt ID (hex), 3-22  
Interrupt handlers, 1-3  
Interrupt only mode, 3-12  
Interrupt priority bus, 1-3  
Interrupt support, 3rd party VME, 3-21

Interrupting the PLC CPU, 3-21  
Isolation, backplane voltage, 2-3

## J

J1 backplane, 2-4  
J2 backplane, 2-4  
J2 option kit, 2-4, 2-5

## L

Location, slot for VME modules, 3-7  
Logicmaster 90, programming with, 5-1

## M

Mechanical restrictions, 2-3  
Mechanical structure, 1-1  
Memory, dual-ported, 2-7  
Module address allocation, 3rd party, 3-1  
Module address allocation, Series 90-70,  
    3-2  
Module configuration, 3-8  
Module location in rack, 4-1  
Module requirements, 3rd party, 3-21  
    dual port memory, 3-21  
    interrupt ID, 3-21  
    IRQ6, 3-21  
Modules, bus master, 2-6  
Modules, bus slave, 2-7  
Modules, categorization, 2-6

## N

Noise immunity, F-10  
None mode, 3-11

## O

Option kit, VME, 2-4, 2-5

## P

Power requirements, VME-based systems,  
    1-4



Power supplies, 1-3  
Power supply extension cable, F-9  
Power supply, description of, 2-2  
Products, VME qualified, H-1  
Programming considerations, 5-1  
Programming functions, VME  
  list of, 5-1  
  SWAP, 5-18  
  VME READ, 5-2  
  VMEREAD/MODIFY/WRITE, 5-8  
  VME TEST AND SET, 5-11  
  VME WRITE, 5-5

## Q

Qualified VME products, H-1  
Quick compatibility checklist, D-1

## R

Rack  
  dimensions, VME integrator, F-3  
  mounting, VME integrator, F-3  
Rack cooling, 4-1  
Rack fan assembly, 1-4, 4-1, F-11  
Rack, module location, 4-1  
Rack, VME integrator, 2-3, 3-7, F-1  
Racks, expansion, 3-4  
Racks, standard, 3-7  
Reduced mail mode, 3-17  
Remote I/O scanner, 3-7  
Requirements for grounding, 4-1  
Restrictions, mechanical, 2-3  
Retaining modules in rack, F-10

## S

Scanner, remote I/O, 3-7  
Screen, example of configuration, 3-8  
Selection of 3rd party VME modules,  
  guidelines for, 2-1  
Series 90-70 module address allocation,  
  3-2

## Signals

ACFAIL, 1-4  
SYSFAIL, 1-4  
SYSRESET, 1-4

Slot addressing, F-9

Slot location, VME modules, 3-7

Specification, C.1, 2-1

Standard racks, 3-7

Structure, mechanical, 1-1

Subbuses, VME structure, 1-2

Supply, power, 2-2

SYSFAIL signal, 1-4

SYSRESET signal, 1-4

System function, 3-5

## T

Third party module address allocation, 3-1

3rd party module address allocation, 3-1

Trade association, international, VITA, E-1

Two rack power cable, 2-4

## U

Utility bus, 1-3

## V

### VITA

addresses, E-1  
definition of, 1-4  
documents, E-1

### VME

abbreviation definition, 1-1  
compatible products directory, 1-4  
guidelines for selection of 3rd party  
  VME modules, 2-1  
modules, installation, 4-1  
modules, slot location, 3-7  
option kit for J2, 2-4, 2-5  
system, 3-1

VME integrator rack, 2-3, F-1

  fan assembly option, F-11

  functions of, F-1

  grounding considerations, F-9

- I/O connections, F-4
    - jumper configuration, F-4, F-7
    - jumper location and function, F-7
    - mounting, F-4
    - ordering information, F-12
    - rack number ID, F-9
    - rack outline drawing, F-2
    - Series 90-70/VME configuration, F-7
    - slot addressing, F-9
    - specifications, F-11
    - standard configuration, F-7
    - VME configuration, F-8
  - VME Integrator Racks, mounting requirements, F-3
  - VME integrator racks, 3-7
  - VME Interrupt handling, 3-6
  - VME interrupt support, 3rd party, 3-21
  - VME Interrupts, 3-6
  - VME module, 3-8
    - full mail mode, 3-15
    - I/O scan mode, 3-19
    - interrupt only mode, 3-12
    - none mode, 3-11
    - reduced mail mode, 3-17
    - selecting the configuration mode, 3-11
  - VME module, configuration, 3-8
  - VME modules, examples of applications, G-1
  - VME products, qualified, H-1
  - VME READ (VMERD) function, 5-2
  - VME read configuration function, 5-14
  - VME READ/MODIFY/WRITE (VMERMW), 5-8
  - VME SWAP function, 5-18
  - VME TEST AND SET (VMETST), 5-11
  - VME WRITE (VMEWRT), 5-5
  - VME write configuration function, 5-16
  - VME\_CFG\_RD, 5-14
  - VME\_CFG\_WRT, 5-16
  - VMEbus
    - 3U modules, 1-2
    - 6U modules, 1-2
    - backplane, 1-2
    - extender module, 2-7
    - features and options, 1-1
    - functional structure, 1-2
    - handbook, 1-4
    - mechanical structure, 1-1
    - standard definition, 1-1
- ## W
- Width compatibility, bus, 3-5
  - Width, bus, 2-7