

Hardware User's Guide

6" QuickPanel View

IC754VGB06MTD

IC754VHB06MTD

May 2004

GFK-2328

All rights reserved. No part of this publication may be reproduced in any form or by any electronic or mechanical means, including photocopying and recording, without permission in writing from GE Fanuc Automation Americas, Inc.

Disclaimer of Warranties and Liability

The information contained in this manual is believed to be accurate and reliable. However, GE Fanuc Automation Americas, Inc. assumes no responsibilities for any errors, omissions or inaccuracies whatsoever. Without limiting the forgoing, GE Fanuc Automation Americas, Inc. disclaims any and all warranties, expressed or implied, including the warranty of merchantability and fitness for a particular purpose, with respect to the information contained in this manual and the equipment or software described herein. The entire risk as to the quality and performance of such information, equipment and software, is upon the buyer or user. GE Fanuc Automation Americas, Inc. shall not be liable for any damages, including special or consequential damages, arising out of the use of such information, equipment and software, even if GE Fanuc Automation Americas, Inc. has been advised in advance of the possibility of such damages. The use of the information contained in the manual and the software described herein is subject to GE Fanuc Automation America's standard license agreement, which must be executed by the buyer or user before the use of such information, equipment or software.

Notice

GE Fanuc Automation Americas, Inc. reserves the right to make improvements to the products described in this publication at any time and without notice.

© 2004 GE Fanuc Automation Americas, Inc. All rights reserved. QuickPanel View is a trademark of GE Fanuc Automation Americas, Inc. Any other trademarks referenced herein are the property of their respective owners and used solely for purposes of identifying compatibility with the products of GE Fanuc Automation Americas, Inc.

The 6" QuickPanel View has been tested and found to meet or exceed the requirements of U.S. (47 CFR 15), Canadian (ICES-003), Australian (AS/NZS 3548) and European (EN55022) regulations for Class A digital devices when installed in accordance with guidelines noted in this manual.

The FCC requires the following note to be published according to FCC guidelines:

This equipment generates, uses and can radiate radio frequency energy and, if not installed in accordance with this instruction manual, may cause harmful interference to radio communications. It has been tested and found to comply with the limits of a Class A digital device pursuant to Part 15 of the FCC rules, which are designed to provide reasonable protection against harmful interference when operated in a commercial environment. Operation of this equipment in a residential area is likely to cause harmful interference, in which case users will be required to correct the interference at their own expense.

Industry Canada requires the following note to be published:

This Class A digital apparatus complies with Canadian ICES-003.

The following statements are required to appear for Class I Div 2 Hazardous Locations.

1. EQUIPMENT LABELED WITH REFERENCE TO CLASS 1, DIVISION 2, GROUPS A, B, C AND D, HAZARDOUS LOCATIONS IS SUITABLE FOR USE IN CLASS 1, DIVISION 2, GROUPS A, B, C AND D, OR NON-HAZARDOUS LOCATIONS ONLY.
2. WARNING - EXPLOSION HAZARD -SUBSTITUTION OF COMPONENTS MAY IMPAIR SUITABILITY FOR CLASS I, DIVISION 2.
3. WARNING - EXPLOSION HAZARD - DO NOT CONNECT OR DISCONNECT EQUIPMENT UNLESS POWER HAS BEEN SWITCHED OFF OR AREA IS KNOWN TO BE NON-HARZARDOUS.

For a complete list of agency qualifications, please refer to appendix A1.

We want to hear from you. If you have any comments, questions, or suggestions about our documentation, send them to the following email address: doc@gefanuc.com.

Contents

1	Welcome	1
	Getting Started	.2
	Basic Setup	.2
	QuickPanel View Unit Runtime Setup	.3
	Startup	.3
	Shutdown	.4
	Panel Cutouts	.4
	Technical Support	.8
2	Overview	9
	QuickPanel View Hardware	.10
	Layout Diagram	.10
	Block Diagram	.11
	QuickPanel View Software	.12
	Windows CE.NET	.12
	Working with Windows CE	.12
	Backup	.14
	Storage Manager	.15
	System Information	.15
	Emulate PPC	.15
	HTTP File Transfer Utility	.17
3	Detailed Operation	19
	Touch Screen Display	.20
	Touch Screen	.22
	Keyboard	.25
	Soft Input Panel	.25
	Communication Port	.29
	COM1- Serial	.29
	Working with the COM port	.30
	Ethernet	.33
	DIP Switches	.37
	Memory	.39
	Flash Memory	.39
	DRAM Memory	.39

Boot Loader ROM	40
Other Subsystems	41
Power Management	41
Battery Backup	41
Real-time Clock	42
A1 Design Specifications	45
Physical	45
DC Power	45
Display	46
Front Panel	46
Touch Screen	46
CPU	46
Memory	47
Communication Port	47
Environmental	47
Battery	48
Calendar/Clock	48
Agency Qualifications	48
A2 Troubleshooting	49
Power up	49
Index	51

1

Welcome

Congratulations on your purchase of a QuickPanel View, the most advanced compact HMI computer available. The QuickPanel View is available in different configurations to suit your requirements. Equally at home in a networked environment or as a stand-alone unit, the QuickPanel View is the ideal solution for factory floor HMI.

Powered by Microsoft Windows CE.NET™, today's embedded operating system of choice, the QuickPanel View provides a fast track for application program development. The commonality with other versions of Windows simplifies porting your existing program code. Another benefit of Windows CE is the familiarity of the user interface, shortening the learning curve for operators and developers alike. The availability of third-party application software makes this operating system even more attractive.

The 6" QuickPanel View is an all-in-one microcomputer designed for maximum flexibility. The design, based on an advanced Intel® microprocessor, brings together a high-resolution operator interface with standard I/O options that connect to most industrial equipment.

The QuickPanel View is equipped with several memory types to satisfy even the most demanding applications. A 16 MB section of DRAM is split between the operating system, an object store, and application memory. A 16 MB section of non-volatile FLASH memory, functioning as a virtual hard drive, is divided between the operating system and persistent storage for application programs.

The many features of the QuickPanel View make it an obvious choice for a world of applications. Your smart choice will provide reliable operation for years to come.

GETTING STARTED

Basic Setup

Your 6" QuickPanel View is shipped ready for use after a few configuration steps. To power up all you need to do is connect a DC power supply via the supplied quick-connect plug. Depending on your application, you may also want to connect and configure communications ports (see page 29).

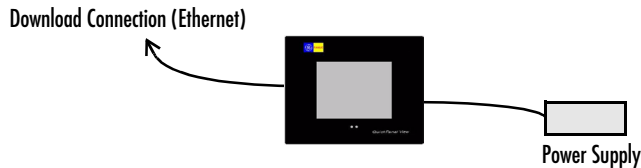

Caution - Electrical Shock Hazard: To avoid personal injury or damage to equipment, ensure that the DC supply is disconnected from power and that the leads are not energized before attaching them to the unit's power supply plug.

To connect a DC power supply

1. Using the three screw terminals shown in the following diagram, attach a 24VDC, 24W power supply to the plug supplied with the QuickPanel View. See the **DC Power** section starting on page 45 for power supply and conductor specifications.
2. Insert the plug into the power supply socket and securely tighten the attaching screws.

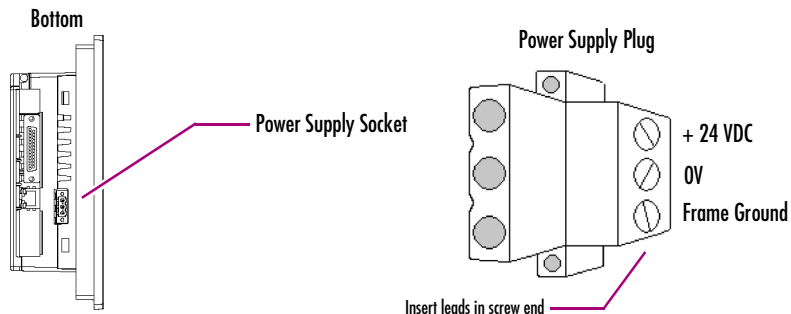

QuickPanel View Unit Runtime Setup

To download an application to a QuickPanel View, you must set up a data link between it and your development workstation. For more information, see “Ethernet” (page 33) and look up “Downloading a Machine Edition Project” in the Machine Edition online help.

Startup

When you first start up the QuickPanel View, a few configuration steps are necessary.

To start the QuickPanel View





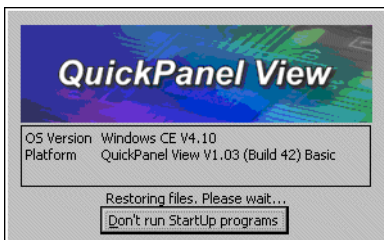



1. Apply AC power to the 24VDC supply.

Once power is applied, the QuickPanel View begins initializing. The first thing to appear on the display is the splash screen.



2. To skip running any programs included in the StartUp folder, tap **Don't run StartUp programs**.

The splash screen disappears automatically after about 5 seconds. The Windows CE desktop then becomes visible.

3. Tap  **Start**, point to  **Settings**, then tap  **Control Panel**.
4. In the Control Panel, double-tap  **Display** to configure the LCD display (see page 20).
5. In the Control Panel, double-tap  **Stylus** to configure the touch screen (see page 22).
6. In the Control Panel, double-tap  **Date and Time** to configure the system clock (see page 42).
7. In the Control Panel, double-tap  **Network and Dial-up Connections** to configure network settings (see page 34).
8. On the desktop, double-tap  **Backup** to save any new settings through a power cycle (see page 14).

Shutdown

There are no specific dangers associated with a power failure or other unplanned shutdown of the QuickPanel View. In general, programs are retained in FLASH memory. Some operating system settings are kept only with user intervention, so in order to carry out a graceful shutdown of the QuickPanel View, we recommend you perform the following procedure.

To shut down the QuickPanel View

1. Quit any programs that are running and wait for all file operations to complete.
2. To save new configuration settings or Windows desktop changes, double-tap  **Backup** on the desktop (see page 14). When backup is complete, tap **OK**. Unsaved changes are lost when power is removed.
3. Remove AC power from the 24VDC supply.

Panel Cutouts

For convenience and versatility, this version of the QuickPanel View can be mounted in cutouts of two different specifications. Refer to the appropriate section that follows.

Small Cutout Dimensions.

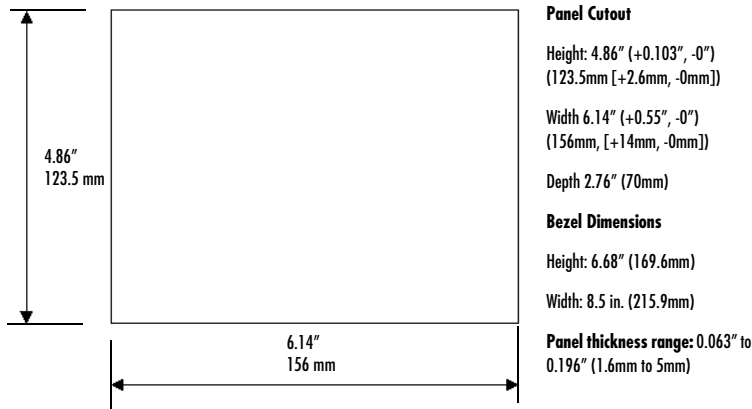

The unit will **not** fit through the small cutout with any cables connected, or with the power supply plug inserted in the socket.

To secure the QuickPanel View to a panel with the small cutout, use the four included mounting clips, which hook into the openings located on the top and bottom of the housing as shown in the following illustration..

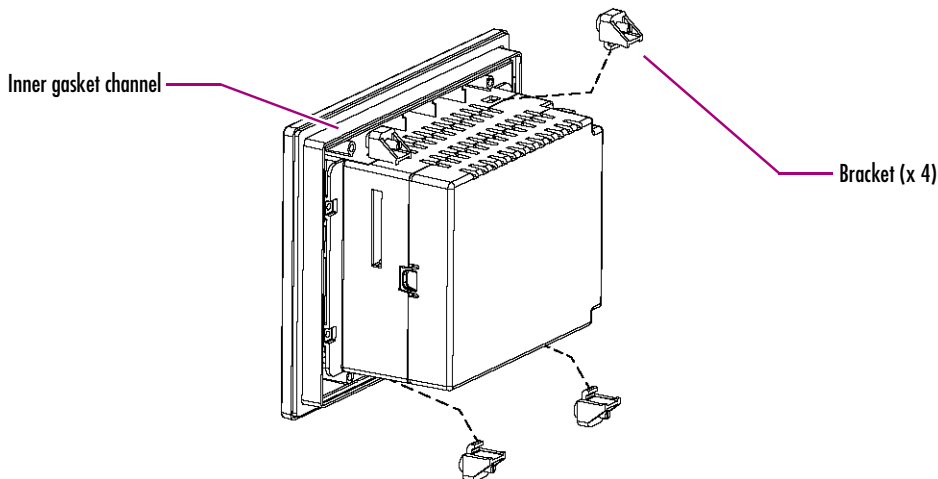

To mount the unit in a panel with small cutout dimensions

1. Separate the small cutout gasket from the supplied gasket sheet (the small cutout gasket is nested within the larger one, and has two notches on each long side). Avoiding damage to the gasket, carefully remove the covering over its adhesive backing, and then apply the gasket with its adhesive surface toward the inner gasket channel (see the illustration above).
2. Verify that the gasket is properly seated in the gasket channel, then insert the unit into the panel cutout.
3. Insert the hook of each mounting bracket in the housing openings.
4. Tighten the screws to 2.6-4.4 inch/lbs (0.3-0.5 Nm).

Notes:

- For compliance to NEMA 4, 4x and 12 qualification, the unit must be mounted in a comparably NEMA rated (IP56 or equivalent) panel or enclosure.
- For compliance to ATEX agency qualification, the unit must be mounted in an IP66 panel or enclosure.
- Do not damage the gasket attached to the back of the unit's bezel. This gasket prevents shock hazards and damage caused by liquids accidentally entering the unit after installation. Also, limit the number of times you remove and reinstall the unit. Too many installations may cause gasket "set" and degradation of the seal. The mounting clips hold the unit in place by tension alone. No drilling is required.

Large Cutout Dimensions

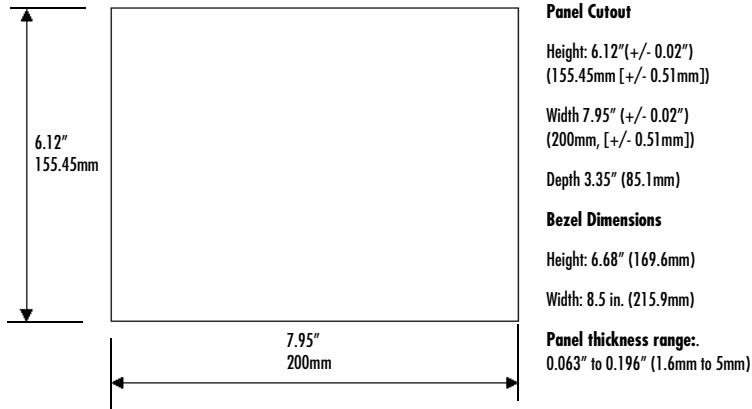

To secure the QuickPanel View to a panel with the large cutout, use the four included mounting clips, which hook into the openings located on the top and bottom of the housing, as well as the four included clip extensions, which slide over the inner portion of the bezel as shown in the following illustration..

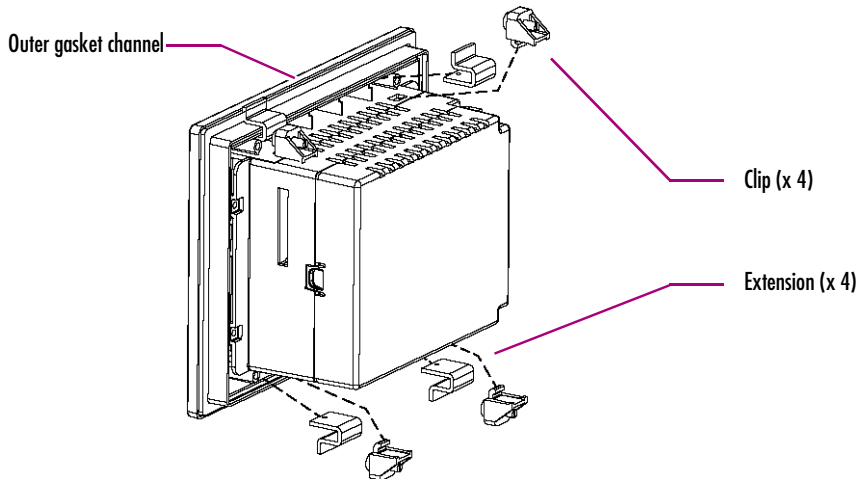

To mount the unit in a panel with large cutout dimensions

1. Separate the large cutout gasket from the supplied gasket sheet (the large cutout gasket surrounds the outside of the sheet). Avoiding damage to the gasket, carefully remove the covering over its adhesive backing, and then apply the gasket with its adhesive surface toward the outer gasket channel (see the illustration above).
2. Verify that the gasket is properly seated in the gasket channel, then insert the unit into the panel cutout.
3. Slide the clip extensions over the inner portion of the bezel, at the location of the mounting clip holes in the housing.
4. Insert the hook of each mounting clip in the housing openings.
5. Tighten the screws to 2.6-4.4 inch/lbs (0.3-0.5 Nm).

Notes:

- For compliance to NEMA 4, 4x and 12 qualification, the unit must be mounted in a comparably NEMA rated (IP56 or equivalent) panel or enclosure.
- For compliance to ATEX agency qualification, the unit must be mounted in an IP66 panel or enclosure.
- Do not damage the gasket attached to the back of the unit's bezel. This gasket prevents shock hazards and damage caused by liquids accidentally entering the unit after installation. Also, limit the number of times you remove and reinstall the unit. Too many installations may cause gasket "set" and degradation of the seal. The mounting clips hold the unit in place by tension alone. No drilling is required.

TECHNICAL SUPPORT

If you have technical problems that cannot be resolved with the information in this guide, please contact us by telephone, fax, or email; or visit one of the links on our website:

Telephone: 1-800-GE-FANUC (1-800-433-2682)

Fax: (780) 420-2049

Email: support@gefanuc.com

Comments about our manuals or help: doc@gefanuc.com

Web: www.gefanuc.com/support (to locate the Technical Advisor page, click on the Operator Interface Product Family link or choose QuickPanel View from the Product List).

For GE Fanuc support, you can also visit:

<http://iglobalcare.gefanuautomation.com>.

2

Overview

This chapter provides introductory information on the 6" QuickPanel View hardware and software with descriptive procedures for completing some of the most common tasks you will encounter.

In this chapter:

QUICKPANEL VIEW HARDWARE	10
Layout Diagram	10
Block Diagram	11
QUICKPANEL VIEW SOFTWARE	12
Windows CE.NET	12
Working with Windows CE	12
To place a program in the Start menu	13
Backup	14
To run the Backup program	14
To reboot the system	14
Storage Manager	15
System Information	15
To run the System Information program	15
Emulate PPC	15
To use Emulate PPC during an ActiveSync session	15
HTTP File Transfer Utility	16
To use the HTTP utility	16

QUICKPANEL VIEW HARDWARE

Layout Diagram

In addition to the primary touch screen interface, the 6" QuickPanel View supports an RS232/485 serial communications port for connection to a wide variety of controllers. The following diagram shows the physical layout of the QuickPanel View and the locations of ports and connections.

The left LED below the display is green when power is applied and amber if the backlight fails;¹ the right LED is tricolor (green, red, or amber) and programmable.

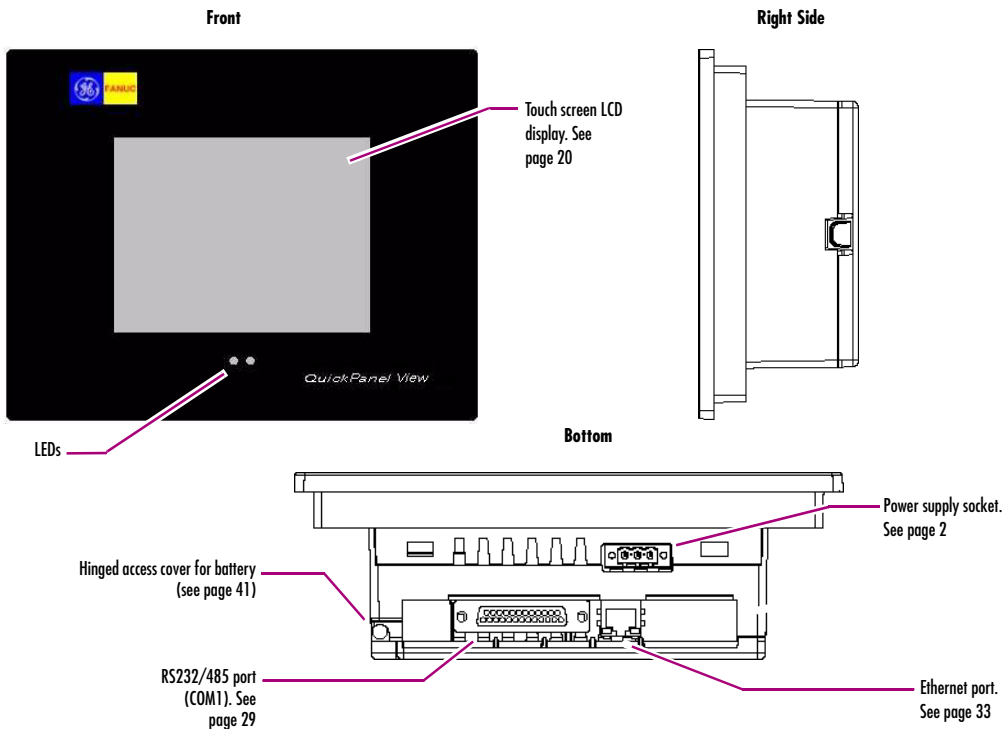

¹ Backlight is not field replaceable.

Block Diagram

The 6" QuickPanel View is based on the Intel® XScale™ PXA255 microprocessor, and employs large-scale integration to provide high performance with a small footprint. The following block diagram illustrates the major functional areas of the QuickPanel View and the interfaces between them.

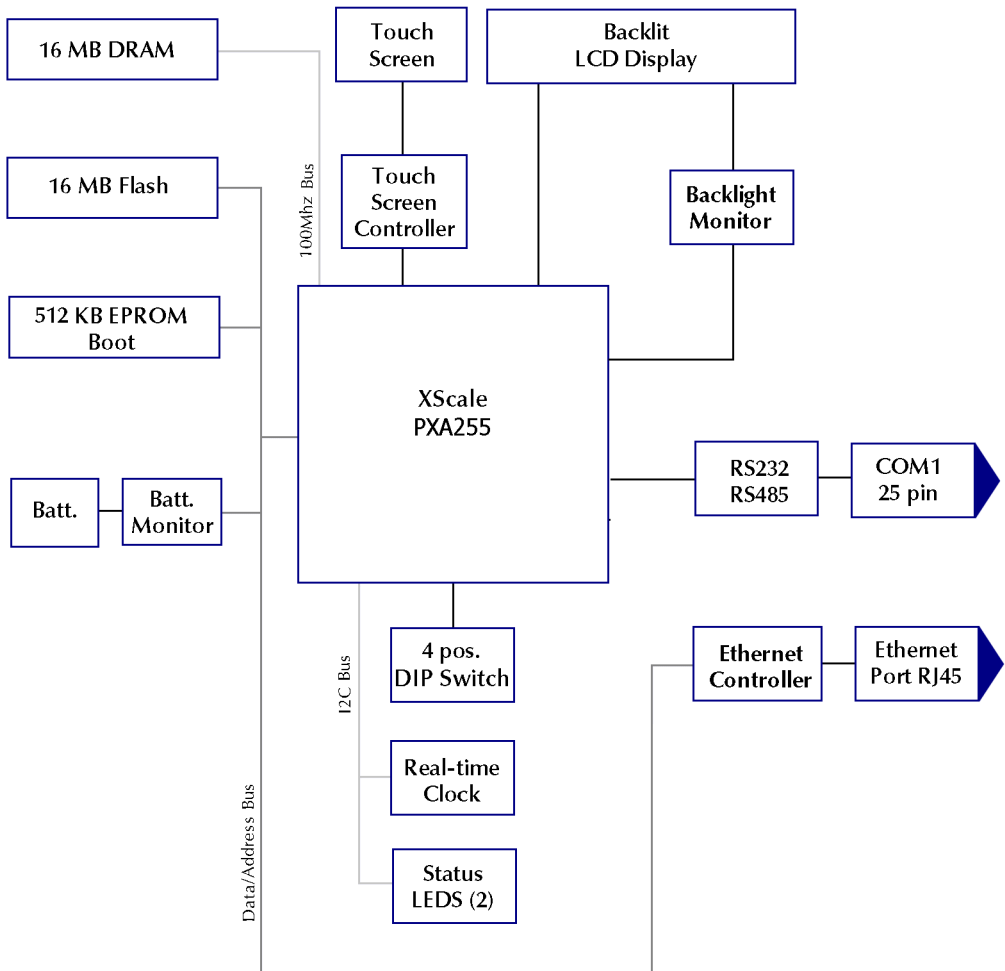

QUICKPANEL VIEW SOFTWARE

Windows CE.NET

Microsoft Windows CE.NET is the operating system for the QuickPanel View. It is a full 32-bit O/S with a graphical user interface. This operating system is finding widespread application in hand-held PCs and embedded HMI's, such as the QuickPanel View. From a user's perspective, the familiar look and feel of the Windows CE environment shortens the learning curve for those having experience with Windows 95/98/NT/2000/ME/XP. From the software developer's perspective, the CE environment is a subset of the WIN32 application programming interface, simplifying the porting of existing software from other versions of Windows.

The QuickPanel View operating system is stored in a 10 MB block of flash memory and executes directly from flash. The operating system also uses a small portion of DRAM. The operating system starts automatically following a power-up or reset of the QuickPanel View.



For more on Windows CE visit www.microsoft.com/windows/embedded/ce.

Working with Windows CE

Although the main user input device when working with Windows CE is the touch screen, it can often be convenient to use keyboard shortcuts, such as those described in the following table.

Keyboard Shortcut	Action
CTRL+ESC or 	Opens the Windows CE Start menu. Use arrow keys to select a program and ENTER to run it.
ALT+TAB	Starts the Task Manager. Use it to quit unresponsive programs.
CTRL+ALT+=	Starts the touch screen calibration.
SPACEBAR	Equivalent to single-tap.
ENTER	Equivalent to double-tap. In a dialog box, equivalent to OK .
TAB	In a dialog box, select next control.
SHIFT+TAB	In a dialog box, select previous control.
CTRL+TAB	In a tabbed dialog box, open the next tab.
ESC	Close dialog box, discarding changes.
ARROW KEYS	In a dialog box, select controls or items from a list .

To place a program in the Start menu

1. Start  Windows Explorer.
2. Navigate to the program you want to place in the  Start menu.
3. Tap the program's icon to select it.
4. From the **Edit** menu, choose **Copy**.
5. Navigate to the ^\Windows\Programs\^ folder.
6. From the **Edit** menu, choose **Paste Shortcut**.
7. Run the  **Backup** program to retain the change through a power cycle (see page 14).

Backup

Backup is a utility that saves any changes made to the Windows Registry or Desktop. This utility is required because, unlike typical handheld Windows CE platforms, the QuickPanel View is not battery powered. Specifically, the Backup command does the following:

- The Windows CE registry (including any control panel settings) is stored in the Flash registry
- Any changes (additions) made to the 'Windows' subtree of the file system are stored in the user block of FLASH memory.

The **Backup** program should be run whenever configuration changes are made to the operating system or installed applications, and prior to shutting down the QuickPanel View.

To run the Backup program



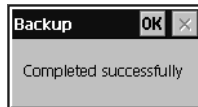

1. On the desktop, double-tap  **Backup**.

The **Backup** dialog box appears.



2. Tap **OK**.

To reboot the system

1. Run the  **Backup** program to retain any changes.
2. Tap  **Start**, point to  **Programs**, then the  **System** folder, and tap  **Reboot**.

A confirmation dialog box appears.

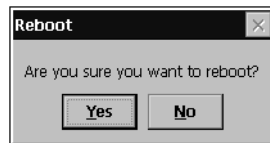

3. Tap "Yes"

The operating system restarts.

Storage Manager

Storage Manager can repair or format some types of lost or corrupted data volumes, but not those existing in the main flash file system. It is not used on this model.

System Information

System Information is a custom utility that displays a splash screen with the following information:

- **Operating System version.** For example, 'Windows CE 4.10'.
- **Platform.** Identifies the host hardware, its version and build number.

Tapping **More Info** on the splash screen opens the Advanced System Information window, which provides information such as hardware version and serial number, CPU type and specifications, etc. This information can be especially useful if you are contacting GE Fanuc Support.

To run the System Information program

1. On the desktop, double-tap  **System Information**.

The **System Information** splash screen appears.

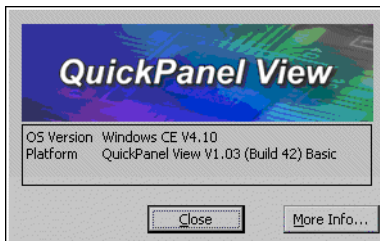

2. Tap **More Info** to open the Advanced System Information window, or tap **Close** to continue.

Network information alone can be viewed by double-tapping the  **LAN** icon displayed on the taskbar for each connection.

Emulate PPC

Emulate PPC is a utility that allows the QuickPanel to emulate a Pocket PC 2003 during an ActiveSync session, enabling the download of third-party Pocket PC 2003 software.

To use Emulate PPC during an ActiveSync session

1. Start  **Windows Explorer**, double tap  **Windows**, then double tap  **EmulPPC**.

The Emulate PPC dialog box appears.

2. Start the ActiveSync session. When installation of third-party software is complete, close the dialog box to deactivate Emulate PPC.

HTTP File Transfer Utility



The HTTP File Transfer Utility (HFTU) is a small, standalone command line program that allows you to send and delete files to and from computers over a network. The HFTU uses the HTTP protocol, so you can even send files to computers over the Internet.

Run the HTTP utility from a command line prompt, from a batch file (.BAT) or as an application call in a script. The HTTP utility is an executable (.EXE) file included in the 6" QuickPanel View's operating system.

The HTTP utility currently supports two file transfer commands: COPY and DELETE.

Note: In order to function, the HTTP File Transfer utility requires both computers to have web servers that support PUT functionality. (Most web servers support PUT, including the CIMPLICITY Machine Edition web server installed with the runtimes for View and Logic Developer - PC.) If in doubt, check the documentation for your web server.

To use the HTTP utility

1. From Programs in the  **Start** menu, choose  Programs, then choose  **Command Prompt**.
The **Command Line** editor appears.

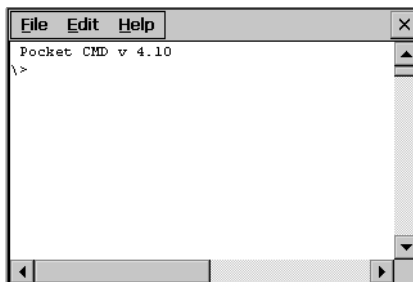

2. Type commands as required.
3. Use the following syntax:

HTTPUTIL COPY source destination

Where "source" is the URL of the source file, and "destination" is the URL of the destination file. For example:

```
HTTPUTIL COPY \MyFile.txt http://MyServer/webfiles/MyFileBACKUP.txt
```

Overview*QuickPanel View Software*

Copies a file called MyFile.txt on drive C: of the local computer to the webfiles folder under the web server at //MyServer. Note that you can rename a file as you copy it.

HTTPUTIL DELETE url

Where "url" is the remote URL of the file you want to delete. This URL must use the "/" or "HTTP:/" syntax. For example:

```
HTTPUTIL DELETE http://MyServer/webfiles/MyFileBACKUP.txt
```

Deletes a file called MyFileBACKUP.txt from the webfiles directory under the web server at HTTP://MyServer.

3

Detailed Operation

In this chapter:

Touch Screen Display	20
To adjust the display contrast	20
To set backlight for auto turn off	21
To calibrate the touch screen	22
To set the double-tap sensitivity	23
Keyboard	25
To show/hide the Soft Input Panel	25
To display the Soft Input Panel icon in the system tray	25
To change key configurations	27
Communication Port	29
To add a new remote networking connection	30
To change the default device properties	31
To change the default TCP/IP settings	32
Ethernet	33
To set an IP address	34
To set up access to a Windows network	35
To access a remote resource on a Windows network	36
DIP Switches	37
To configure startup behavior with DIP switch 2	38
Memory	39
To change the DRAM memory allocation	40
Other Subsystems	41
To access the Power Properties control panel	41
To remove the internal battery	42
To set the real-time clock	42
To display the time on the taskbar	43

TOUCH SCREEN DISPLAY

The QuickPanel View has an integrated backlit flat-panel monochrome display measuring 5.7" diagonally. It uses passive FSTN technology and has a resolution of 320 x 240 pixels, with 256 shades of gray.

To extend backlight life, a timer can be configured to turn it off automatically.

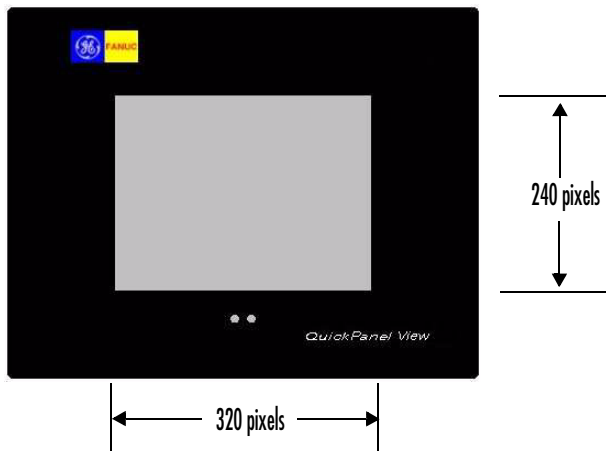

To adjust the display contrast

1. In the Control Panel, double-tap  **Display** and choose the **Contrast** tab.

The **Contrast** dialog box appears.

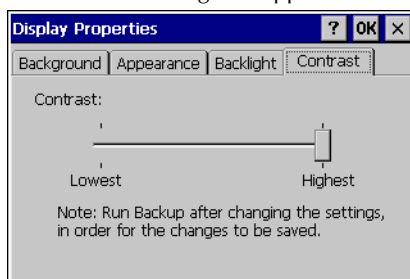



2. Drag the **Contrast** slider between **Lowest** and **Highest**.
3. Tap **OK** to exit the control panel.
4. Run the  **Backup** program to save settings through a power cycle (see page 14).

To set backlight for auto turn off

1. In the Control Panel, double-tap  **Display** and choose the **Backlight** tab.

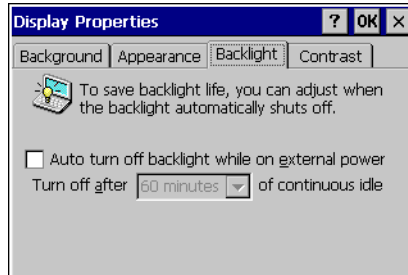
The **Backlight** dialog box appears.



2. Select **Auto turn off backlight while on external power**.
3. Tap **OK** to exit the control panel.
4. Run the  **Backup** program to save settings through a power cycle (see page 14).

Touch Screen

The QuickPanel View display is coupled to a resistive touch panel with 12-bit resolution. When the QuickPanel View is properly calibrated, this translates into a grid of touch cells on the face of the display. Although you can use your finger to actuate the touch screen, use of a blunt stylus is recommended.

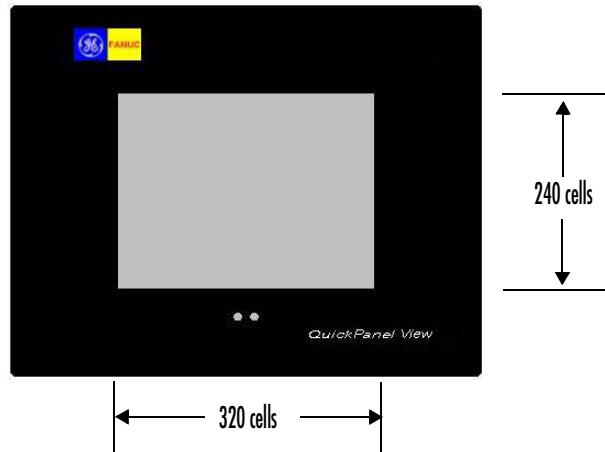

To calibrate the touch screen

1. In the Control Panel, double-tap  **Stylus**.

The **Stylus Properties** dialog box appears.



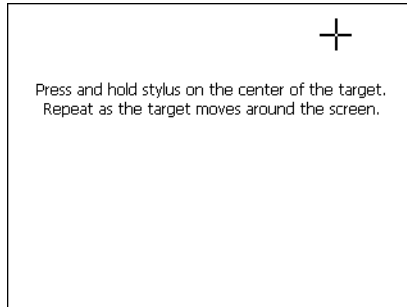

2. Choose the **Calibration** tab
3. Tap the **Recalibrate** button.

A cross hair target is displayed.

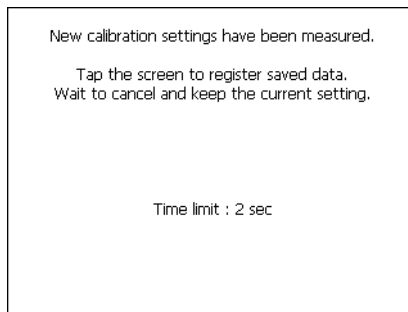

4. Follow the directions given to calibrate the touch screen.
5. Tap the screen to preserve the new setting or wait out the time limit to revert to previous settings.



6. Run the  **Backup** program to save the settings through a power cycle (see page 14).

To set the double-tap sensitivity

1. In the Control Panel, double-tap  **Stylus**.

The **Stylus Properties** dialog box appears.

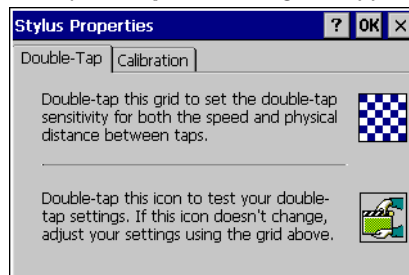

Detailed Operation

Touch Screen Display

2. Choose the **Double-Tap** tab.
3. Double-tap the grid to enter a setting.
4. Double-tap the test icon to check the setting.

If the test icon doesn't change when you double-tap it, double-tap the grid again.

5. Tap **OK** to finish.
6. Run the  **Backup** program to save the settings through a power cycle (see page 14).

KEYBOARD

The QuickPanel View can be configured to use a software emulation keyboard as the operator input device.

Soft Input Panel

The Soft Input Panel (SIP) is a touch screen version of a standard keyboard, which can be used in place of a standard hardware keyboard.

An icon in the system tray lets you view or hide the SIP.

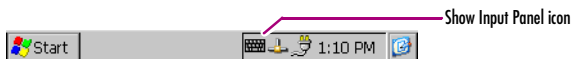

To show/hide the Soft Input Panel

- On the system tray of the task bar, double-tap the  icon. The Soft Input Panel appears/disappears.

Note: When the SIP is visible, it can be dragged around the screen by its title bar to reveal different parts of the screen that would be obstructed from view by the SIP.

To display the Soft Input Panel icon in the system tray

1. In the Control Panel, double-tap  **Input Panel**.

The **Input Panel Properties** dialog box appears.

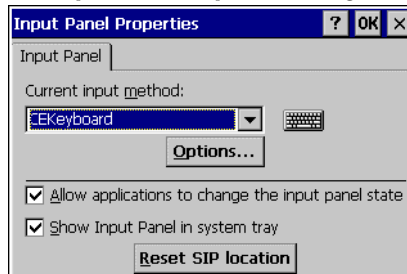

2. Select the **Allow applications to change the input panel state** check box.
3. Select or clear the **Show Input Panel in system tray** check box.
4. Tap **Reset SIP location** to reset the SIP to its original location on the desktop when displayed.
5. Tap **OK**.
6. Run the  **Backup** program to retain the new setting through a power cycle (see page 14).

The Soft Input Panel has two basic configurations: **Small key** and **Large key**.

Detailed Operation

Keyboard

Small Key configuration: Provides a standard QWERTY key layout with numeric keys at the top row as illustrated in the following picture.

Input Panel															
Esc	1	2	3	4	5	6	7	8	9	0	-	=	←		
Tab	q	w	e	r	t	y	u	i	o	p	[]			
CAP	a	s	d	f	g	h	j	k	l	;	'				
Shift	z	x	c	v	b	n	m	,	.	/		←			
Ctl Alt	~											↓	↑	←	→

Small key: lower case

Uppercase characters are accessed by pressing the SHIFT key once. This is equivalent to holding down the SHIFT key on a conventional keyboard. The SHIFT key is active while the next key is pressed then reverts back to its unselected state. The CAP key does the same thing as SHIFT but does not revert to lower case after another key is pressed. Rather, the Soft Input Panel remains in the Uppercase mode until the CAP key is pressed again. The CTRL and ALT keys behave the same as the SHIFT key

Input Panel															
Esc	!	@	#	\$	%	^	&	*	()	_	+ Del			
Tab	Q	W	E	R	T	Y	U	I	O	P	{	}			
CAP	A	S	D	F	G	H	J	K	L	:	"				
Shift	Z	X	C	V	B	N	M	<	>	?		←			
Ctl Alt	~											↓	↑	←	→

Small key: upper case

Large Key configuration: Provides alphabetic or numeric keys alone. No numeric keys are displayed at the top of the alpha panel; alpha keys are not displayed on the numeric panel.

Input Panel															
Esc	q	w	e	r	t	y	u	i	o	p		←			
Tab	a	s	d	f	g	h	j	k	l	*					
Shift	z	x	c	v	b	n	m	:	'			←			
123 Ctl Alt	@	&										,	.	/	?

Large key: lower case

As with the small key configuration, upper or lower case alpha keys can be displayed by using the SHIFT key.



Large key: upper case

Pressing the **123** key once locks the panel in numeric mode until the **123** key is pressed again.

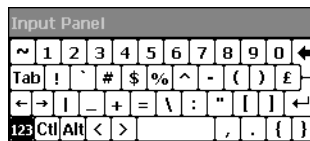

Large key: numeric

To change key configurations

1. In the Control Panel, double-tap  **Input Panel**.

The **Input Panel Properties** dialog box appears.

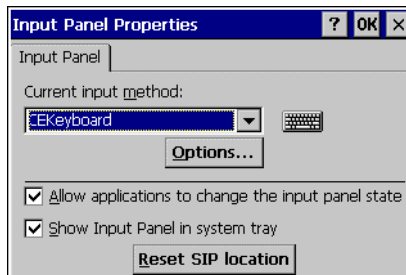

2. From the **Current input method** list, choose **CE Keyboard**.
3. Tap **Options**.

The **Soft Keyboard Options** dialog box appears.

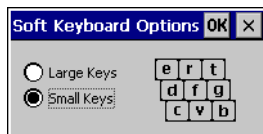

4. Select **Large Keys** or **Small Keys**.

Detailed Operation*Keyboard*

A preview of the key size is displayed on the dialog box.

5. Tap **OK** twice to finish.
6. Run the  **Backup** program to save the settings through a power cycle (see page 14).

COMMUNICATION PORT

The QuickPanel View has one serial data communication port (COM1).

COM1 - Serial

The COM1 port is a general purpose bidirectional serial data channel that supports the EIA232C and EIA485 electrical standards. The COM1 port can be accessed and configured:

- as a direct or dial-up remote networking connection.
- from a user-created application program.

A connection can be configured to reside on a network supporting a TCP/IP protocol.

A DB25S (female) connector, mounted on the side of the enclosure, provides standard signals as described in the following table.

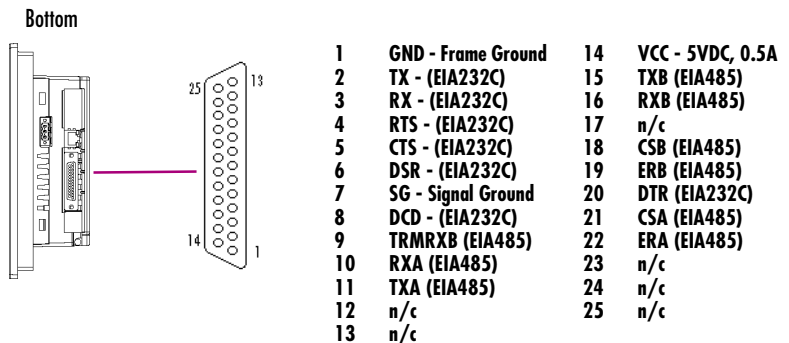



Notes:

- Pin 14 is fused with a field-replaceable, 1A fast-blow fuse.
- Twisted pair cabling is required when using EIA485 communications.
- When using in EIA485 mode, RXA/RXB termination should be used if the unit is the last node on the 485 network. A termination resistor is included and is used by connecting pin 9 to pin 10.
- When using in EIA485 mode, pin 7 (ground) should not be used.

Working with the COM port

To add a new remote networking connection

1. From the  **Start** menu, tap  **Settings**, then  **Network and Dial-up Connections**.
The **Connection** window appears.

2. Double-tap  **Make New Connection**.

The **Make New Connection** wizard appears.

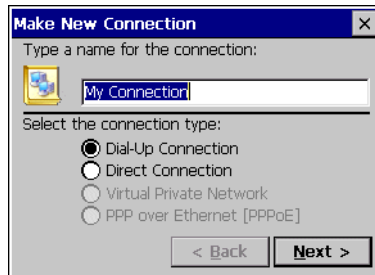

3. Type a name for the new connection.
4. Choose a connection type.
5. Tap **Next**.

The **Modem** or **Device** dialog box appears, depending on the connection type.

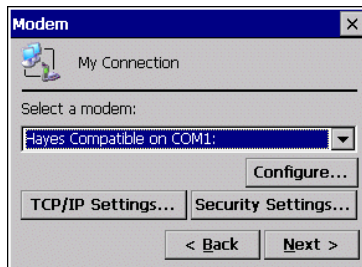

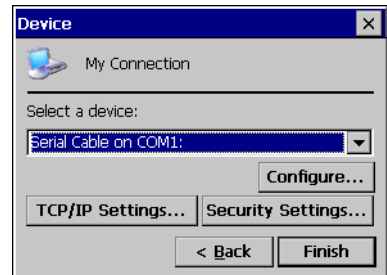

or

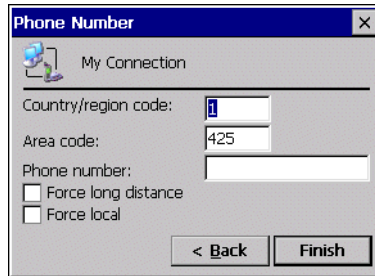

6. From the list, choose the device or modem you want to use.
You can **Configure** your device or **TCP/IP Settings** at this time if you wish.
7. Tap **Finish** for direct connection (Device dialog box) or **Next** for dial-up (Modem dialog box).

If you are adding a dial-up connection the following dialog box appears.



8. Type the destination **Country/region code**, **Area code**, and **Phone number** in the appropriate boxes.
9. Select or clear the **Force Long Distance** or **Force Local** check boxes.
10. Tap **Finish**.
11. Run the  **Backup** program to save the settings through a power cycle (see page 14).

To change the default device properties

1. From either the Device or Modem dialog box, tap **Configure**.

The **Device Properties** dialog box appears.

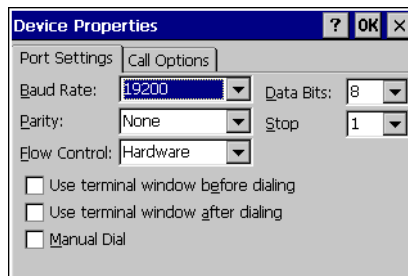



2. In the **Port Settings** tab, choose settings for all connection preferences.
3. If the connection is for terminal emulation, select or clear the terminal-related check boxes.

To change the default TCP/IP settings

1. Obtain correct TCP/IP settings from your network administrator.
2. From either the **Device** or **Modem** dialog box, tap **TCP/IP Settings**.

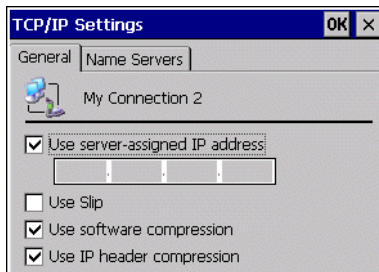
The **TCP/IP Settings** dialog box appears.



3. Use the TCP/IP settings from your internet provider.
4. Run the  **Backup** program to save the settings through a power cycle (see page 14).

ETHERNET

The QuickPanel View is equipped with a 10/100BaseT auto-negotiate Ethernet port (IEEE802.3), and you can connect an Ethernet network cable (unshielded, twisted pair, UTP CAT 5) to the unit via the RJ45 connector on the bottom of the enclosure. LED indicators on the port indicate channel status. Access to the port is possible either by Windows CE network communications, or by your custom application. The following diagram shows the location, orientation, and pin out of the Ethernet port.

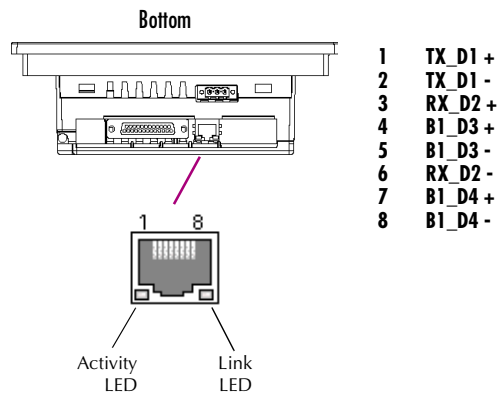

There are two methods for setting an IP address on the QuickPanel View:

- **DHCP (Dynamic Host Configuration Protocol).** This is the default method that is carried out automatically.

Note: There must be a DHCP server on the connected network for a valid IP address to be assigned. Contact your network administrator to ensure correct DHCP server configuration.

- **Manual method.** The user uniquely specifies the numeric addresses for the QuickPanel View, the Subnet Mask (if applicable), and the Default Gateway.

Note: Use a crossover cable to connect the QuickPanel View to a PC directly; when connecting to a LAN HUB, use a straight through cable. Contact your network administrator if you require further information.

To set an IP address

1. From the Control Panel, tap  **Network and Dial-up Connections**.

The **Connection** window appears.



2. Select a  connection and choose  **Properties**.

The **Built-in Ethernet Port Settings** dialog box appears.

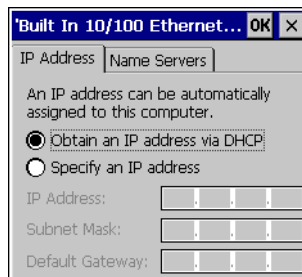

3. Select a method:
 - **Obtain an IP address via DHCP** (automatic).
 - **Specify an IP address** (manual).
4. Enter the **IP Address**, **Subnet Mask** and **Default Gateway** numbers obtained from your network administrator (manual method only).
5. Tap **OK**.
6. Run the  **Backup** program to retain the new settings through a power cycle (see page 14).
7. **Restart the QuickPanel View.**

If the DHCP method was selected, the network server will assign an IP address while the QuickPanel View is initializing. (You must be connected to the network).

After setting an IP address for the QuickPanel View, you can access any network drives or shared resources for which you have permission.

To set up access to a Windows network

1. In the Control Panel, double-tap  **System**.

The **System Properties** dialog box appears.

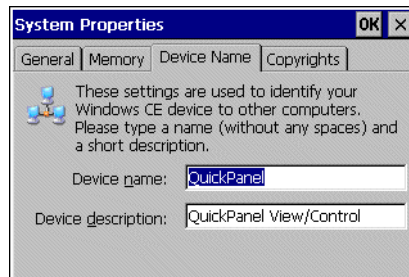

2. On the **Device Name** tab, in the **Device name** box, type a unique name for your QuickPanel View. In the **Device description** box, type a description.
3. Tap **OK**.
4. In the Control Panel, double-tap  **Owner**.

The **Owner Properties** dialog box appears.

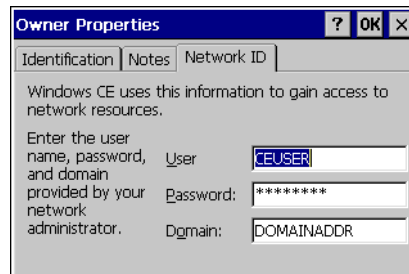

5. On the **Network ID** tab, type your assigned **User name**, **Password** and **Domain**.
6. Tap **OK**.
7. Run the  **Backup** program to retain the settings through a power cycle (see page 14).

Using Windows CE Explorer, you can now access anything on your local network for which you have permission.

To access a remote resource on a Windows network

1. Start  **Windows Explorer**.

The **Explorer** window appears.

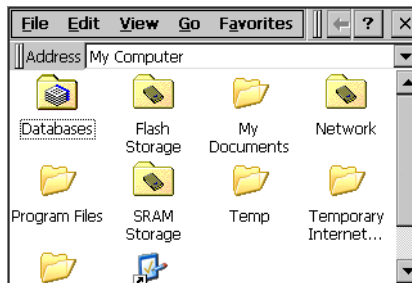

2. Type in the **Address** box, or choose from a list, the path to a remote resource.

For example ‘\\MyRemoteComputer\MyFolder’ specifies the folder named ‘MyFolder’ on a computer with the name ‘MyRemoteComputer’.

3. Press **ENTER**.

The resource specified is displayed as a collection of files and folders. It can take a few moments to retrieve the data from your local network.

Note: You can use the NET command from the shell to map a network resource to the QuickPanel View for frequent access. The resource then appears in the

 **Network** folder.

DIP SWITCHES

The QuickPanel View is equipped with four DIP switches that each control separate functions.

DIP switches are set to “OFF” by default in the factory. DIP switch 2 is the Force Startup switch. Turning this switch on forces the startup applications to run when the operating system is started.

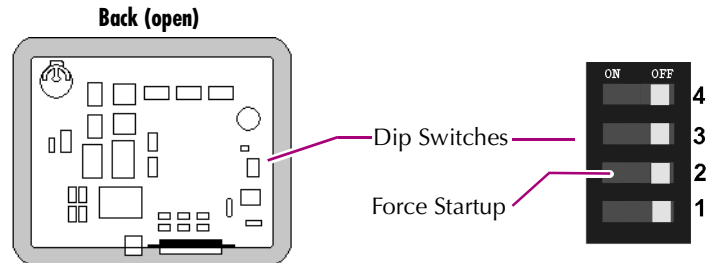

When the switch is set to “OFF”, the QuickPanel View operates normally, displaying the startup splash screen. You can skip running the startup applications by tapping the “Don’t run StartUp Programs” button on the startup splash screen.

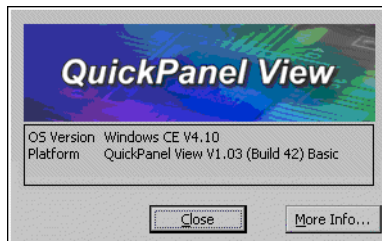

When the switch is set to “ON”, the startup programs are forced to run and the “Don’t run Startup Programs” button is not available on the startup splash screen.

Note: Do not adjust switches other than switch 2. They are reserved for factory functions. Also note that the “On” position of the switches is toward the inside of the unit, “Off” toward the outside edge, and that switch 1 is closest to the bottom.

To configure startup behavior with DIP switch 2



Caution: Remove power from the QuickPanel View before opening the back. Working on a “live” unit may result in damage to equipment and injury to personnel. Always use anti-static precautions (i.e. grounded wrist strap) when accessing the interior of the unit.

1. Open the back cover of the QuickPanel View.
2. Locate the DIP switches and set DIP switch 2 to “ON”.

The startup applications are now forced.



Note: Do not adjust the other switches. They are reserved for factory functions.

MEMORY

The QuickPanel View supports a variety of memory subsystems to ensure the requirements of your application are met. All system memory is tied directly to the microprocessor's address and data busses for fastest access.

Flash Memory

This 16 MB block of non-volatile memory is the main long-term program storage for the QuickPanel View, operating like a virtual hard drive from the point of view of Windows CE. It is divided into two areas, of which only one is accessible from Windows CE Explorer. The  **Flash Storage** folder represents a 6 MB block of memory (approximately) available for long-term storage of user application programs. The other 10 MB is used to store the Windows CE operating system, and is not directly accessible from Windows CE Explorer.

The operating system executes directly from flash while application programs are transferred from flash to DRAM for execution. Any user additions to the  **Windows** folder are retained in  **Flash Storage** when the  **Backup** utility is run.

FLASH memory has a limited write-cycle lifetime. That is, the physical memory devices wear out after approximately 100,000 cycles (minimum), so it is advisable to limit file operations such as copy, delete, etc.

The write cycle is much slower for FLASH than it is for other portions of RAM, therefore FLASH is not recommended for the storage of program variables, or any data items whose values are dynamic.

DRAM Memory

The QuickPanel View is equipped with approximately 16 MB of dynamic RAM, which is split between an object store for temporary file storage and the main memory for running programs.

Typically, compressed programs stored in FLASH are expanded and moved to DRAM for execution. Temporary storage of program variables or data files is also provided by DRAM—any data stored in DRAM will not be retained through a power cycle.

The split between program memory and storage memory may be adjusted as necessary to make more room for one or the other, depending on your specific application needs. For example, if you find that an application is short of memory, use the System Properties dialog box to alter DRAM memory allocation.

Detailed Operation

Memory

Caution: Setting Program Memory too low may prevent additional applications from starting, or may cause currently running applications to fail due to lack of memory. Setting Storage Memory too low may prevent the saving of files into the object store portion of the file system, which may also cause application failures.

To change the DRAM memory allocation

1. In the Control Panel, double-tap  **System**.

The **System Properties** dialog box appears.

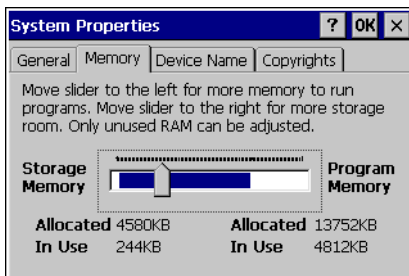

2. On the **Memory** tab, drag the slider to divide the DRAM into Storage and Program memory.

The amount of memory allocated to and used by each area is displayed numerically. The blue bar indicates the current amount of unallocated DRAM and determines the boundaries within which the slider can move.

3. Tap **OK** to apply the new setting.
4. Run the  **Backup** program to retain the new setting through a power cycle (see page 14).

Boot Loader ROM

The Boot Loader ROM provides 512 KB of non-volatile storage for the QuickPanel View's initialization program. This program configures the QuickPanel View hardware then starts the operating system's execution. This memory is not accessible from Windows CE Explorer, nor should any attempts be made to modify the contents of this ROM.

OTHER SUBSYSTEMS

Power Management

The QuickPanel View's Power Properties control panel displays the status of the backup battery. The  Battery Very Low Or Missing icon displays in the taskbar when the battery is either missing or very low.

To access the Power Properties control panel

1. In the Control Panel, double-tap  Power.

The Power Properties dialog box appears.



Battery Backup

Auxiliary backup power for the real-time clock and SRAM is provided by a **non-rechargeable**, internal lithium battery (+3VDC, CR2032), ensuring that no loss of data occurs when the main 24VDC supply is removed. Backup power is enabled or disabled by installing or removing the battery, accessed via the rear panel as shown in the following illustration.

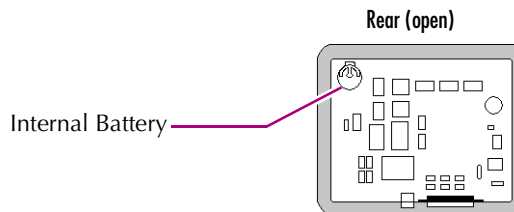

Caution: Remove power from the QuickPanel View before opening the back. Working on a “live” unit may result in damage to equipment and injury to personnel. Always use anti-static precautions when accessing the interior of the QuickPanel View.



To remove the internal battery

1. Disconnect AC power from the 24VDC supply.
2. Open the rear access panel.
3. Release the battery by *gently* lifting it from the completely exposed side, past the small protrusions. To avoid breaking the battery retainer clips, do not apply excessive upward pressure.
4. Slide the battery out of its carrier, noting the arrow on the carrier indicating the direction of removal.

Real-time Clock

The QuickPanel View has a programmable real-time clock capable of reporting the current time in Year/Month/Day/Hour/Minute/Second. The time is set from the Windows CE interface and retained through a power cycle if battery backup is available. Automatic adjustment for daylight savings time is enabled by a check box within the dialog box. The time can be displayed in the system tray on the task bar.

To set the real-time clock

1. In the  Control Panel, double-tap  **Date/Time**.

The **Date/Time Properties** dialog box appears.

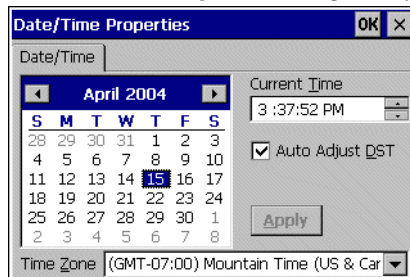

Note: Tap Apply after making changes in any box.

2. Tap the year to choose a new year; tap the month to choose a new month.
3. Tap a date to specify the day of month.
4. From the **Time Zone** box, choose your zone.
5. Select **Auto Adjust DST** to have the clock automatically compensate for daylight savings time.
6. In the **Current Time** box, adjust the hours, minutes and seconds.
7. Tap **OK** to finish.

To display the time on the taskbar

1. From the  **Start** menu, choose  **Settings**, then  **Taskbar and Start Menu...**

The **Taskbar Properties** dialog box appears.

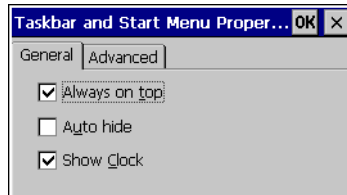

2. On the **Taskbar Options** tab, select **Show Clock**.
3. Tap **OK**.

An hours and minutes display now appears in the taskbar.

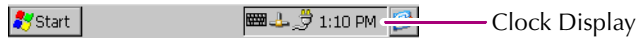

A1

Design Specifications

The specifications listed in this appendix are the design goals for the QuickPanel View. In most cases the “as built” or tested specifications are identical. See page 48 for a list of agency approvals for environmental service and safety.

Physical

Enclosure dimensions	Height: 4.852 in (123.2mm) Width: 6.14 in (156mm) Depth: 2.76 in (70mm)
Bezel dimensions	Height: 6.68 in (169.6mm) Width: 8.50 in. (215.9mm) Depth: 1.13 in (28.7mm) - using small cutout 0.28 in (7.11mm) - using large cutout
Weight	2.5lb (1.16 kg)
Cutout dimensions	Small: Height: 4.86", +0.103", -0" (123.5mm, +2.6mm, -0mm) Width: 6.14", +0.55", -0" (156mm, [+14mm, -0mm]) Large: Height: 6.12", +/- 0.02" (155.45mm [+/- 0.51mm]) Width: 7.95", +/- 0.02" (202mm, [+/- 0.51mm])

DC Power

Input Voltage	10.8 to 30 VDC (12 VDC +/- 10% regulated power supply; 24 VDC +/- 20% power supply)
Real Power	9W Power requirement nominal for startup when DC supply is already powered and stable. Applying power to the supply while connected to the QuickPanel View increases total inrush current requirements. In this case, supply should be rated at 10x the nominal startup current. Otherwise, an interposing relay or switch must be used between the DC supply and the QuickPanel View. NOTE : For compliance with UL 1604, switches or relays in-line with the DC power wiring cannot be used in hazardous locations.
Connector (Vendor, p/n)	Phoenix Contact, 1777992

Design Specifications

Power Supply Conductor Size	12 to 18 AWG For compliance to CE Mark, the isolated frame ground must be connected. Recommended frame ground connection is via the shortest possible route, using a 14 AWG conductor.
-----------------------------	--

Display

Size	5.75" 14.6 cm
Colors	256 shades of gray
Resolution	320 X 240
Fabrication	Passive FSTN
Backlight	Cold Cathode Fluorescent (CCFL) - rated half life: 50,000 hours Backlight not field replaceable.

Front Panel

Bezel Material	Valox 357U For material specifications, visit www.gepolymerland.com
Membrane Material	Lexan HP60 For material specifications, visit gestructuredproducts.com
LEDs	
Left	Power status indicator (green with power applied, amber if backlight fails)
Right	Programmable tri-color (green, red, amber)

Touch Screen

Type	Resistive, 12 bit
Resolution	X axis- 320 cells Y axis - 240 cells (after calibration)

CPU

Processor	Intel XScale PXA255
Clock speed	200 Mhz

Memory

FLASH	16 MB
DRAM	16 MB
ROM	512 KB (Boot loader)

Communication Port

Ethernet	IEEE 802.3 10/100BaseT RJ45 connector Two status LEDs Maximum cable length: 30M
Serial COM1	EIA232C/EIA485, DP25S (female)
Speed	300 bps - 115200 bps
Mounting h/w	M2.6 jackscrew
Fuse	1.0A, 125V fast blow cartridge type, Littlefuse part #154001

Environmental

Operating Temperature	14°F to 140°F (-10°C to 60°C)
Operating Humidity	10% to 85%, non-condensing
Storage Temperature	-4 to 158°F -20 to 70 °C
Storage Humidity	10% to 85%, non-condensing
NEMA Rating	4, 4x, and 12 when mounted in a panel (IP65 equivalent)
Operational Vibration	IEC 68-2-6 10 - 57Hz, 0.012" peak to peak displacement 57 - 500Hz, 1.0g acceleration
Operational Shock	IEC 68-2-27 15g, 11ms (sine wave)

Battery

Type	CR2032 (3V, 190mAh, lithium)
Life (Approximate)	5 years

Calendar/Clock

Resolution	1 second
Retention	Life of battery

Agency Qualifications

Model # ES0600

Description	Agency Standard or Marking	Comments
North American Safety for Industrial Control Equipment	UL 508/C-UL	Certification by Underwriter's Laboratories to UL standard and equivalent CSA standard
North American Safety for Hazardous Locations Class I, Div. 2, Groups A, B, C, D	UL 1604/C-UL	Certification by Underwriter's Laboratories to UL standard and equivalent CSA standard
Explosive Atmospheres Directive European Safety for Hazardous Locations Equipment Group II, Category 3	ATEX (pending)	Certification in accordance with European directives; refer to Declaration of Conformity and Independent 3 rd Party Assessment Certificate
Low Voltage Directive European Safety for Industrial Control Equipment	CE	Self-declaration in accordance with European directives; refer to Declaration of Conformity
Electromagnetic Compatibility Directive European EMC for Industrial Control Equipment	CE	Certification by competent body in accordance with European directives; refer to Declaration of Conformity

A2

Troubleshooting

The tables contained in this appendix can be used to identify and remedy problems that can occur with the 6" QuickPanel View.

Power up

Problem	Suggested remedy
Blank screen.	Check all power connections to the QuickPanel View. Note: Left LED glows amber when backlight fails.

Index

A

- accessing
 - Windows network 35, 36
- adding
 - connections 30
- addresses
 - IP 34
- adjusting
 - display contrast 20

B

- backlight
 - (note) 10, 46
 - set for auto turn off 21
- backup 14
- battery 41
 - specifications 48
 - status 41
- baud rate 31
- bezel 46
- block diagram 11
- boot loader ROM 40

C

- calibrating
 - touch screen 22
- clock 42
- COM1 29
- communication ports 29, 47
- configuring
 - set IP address 34
 - TCP/IP settings 32
- connections
 - adding 30
 - set IP address 34
 - TCP/IP settings 32
 - Windows network 35

contrast 20

- cutout 4
 - see also design specifications

D

- design specifications 45
- device properties, configuring 31
- DHCP (Dynamic Host Configuration Protocol) 33
- dial-up connection 30
- dip switches 37
- displaying
 - real-time clock 43
- double-tap sensitivity
 - setting 22, 23
- DRAM 39
 - partition DRAM memory 40
 - partitioning 39

E

- Emulate PPC 15
- Ethernet 33
 - port settings 34

F

- flash 39
- flow control 31
- front panel 10, 46
 - bezel 46
 - LEDs 10, 46
 - membrane 46

I

- input panel 25
 - displaying 25
- IP address
 - setting 34

K

- key configurations
 - changing 27
 - large 26
 - small 26
- keyboard 25
- keyboard shortcuts 12

L

- LEDs
 - Ethernet 33, 47
 - front panel 10, 46

M

- membrane 46
- memory 39, 47
 - boot loader ROM 40
 - DRAM 39
 - flash 39
 - partition DRAM memory 40
- modem configuration 30
- mounting
 - dimensions 4
 - hardware 5, 6
 - mounting directions 5, 7
- mounting brackets 5, 7

P

- panel cutout 4
 - see also design specifications
- parity 31
- partitioning
 - DRAM 39
- physical layout 10
- ports
 - communication 29, 47
 - Ethernet 33

- keyboard 25
- locations 10
- serial 29
- power management 41
 - control panel 41
- power supply 2
- power supply terminals
 - location 10
- product support 8
- programs
 - start menu 13

R

- real-time clock 42
 - displaying 43
 - setting 42

S

- serial ports 29

- setting
 - double-tap sensitivity 23
 - sensitivity 22
 - IP address 34
 - real-time clock 42
- setup
 - basic 2
 - runtime 3
- shutdown 4
- specifications 45
- start menu 13
- startup 3
 - configuring behavior 38
 - force startup switch 37
 - stop startup programs 37
- storage card 39
- storage manager 15
- support 8
- switches, dip 37

- System Information 15

T

- Technical Advisor 8
- technical support 8
- touch screen 22
 - calibrating 22
- troubleshooting 49

U

- utilities
 - backup 14
 - System Information 15

W

- Windows CE 12
- Windows network
 - accessing 35, 36