

GFK-1411

[Buy GE Fanuc Series 90-30 NOW!](#)

GE Fanuc Manual Series 90-30

System Manual for Windows Users

1-800-360-6802
sales@pdfsupply.com



GE Fanuc Automation

Programmable Control Products

*Series 90™-30 System Manual
for Windows® Users*

GFK-1411C

May 2000

Warnings, Cautions, and Notes as Used in this Publication

Warning

Warning notices are used in this publication to emphasize that hazardous voltages, currents, temperatures, or other conditions that could cause personal injury exist in this equipment or may be associated with its use.

In situations where inattention could cause either personal injury or damage to equipment, a Warning notice is used.

Caution

Caution notices are used where equipment might be damaged if care is not taken.

Note

Notes merely call attention to information that is especially significant to understanding and operating the equipment.

This document is based on information available at the time of its publication. While efforts have been made to be accurate, the information contained herein does not purport to cover all details or variations in hardware or software, nor to provide for every possible contingency in connection with installation, operation, or maintenance. Features may be described herein which are not present in all hardware and software systems. GE Fanuc Automation assumes no obligation of notice to holders of this document with respect to changes subsequently made.

GE Fanuc Automation makes no representation or warranty, expressed, implied, or statutory with respect to, and assumes no responsibility for the accuracy, completeness, sufficiency, or usefulness of the information contained herein. No warranties of merchantability or fitness for purpose shall apply.

The following are trademarks of GE Fanuc Automation North America, Inc.

Alarm Master	Genius	PROMACRO	Series Six
CIMPLICITY	Helpmate	PowerMotion	Series Three
CIMPLICITY 90-ADS	Logicmaster	PowerTRAC	VersaMax
CIMSTAR	Modelmaster	Series 90	VersaPro
Field Control	Motion Mate	Series Five	VuMaster
GEnet	ProLoop	Series One	Workmaster

This manual accompanies Control software versions 2.4 and later, VersaPro software versions 1.0 and later, and is applicable to version 10.0 of the Series 90-30 PLC CPUs.

Revisions to This Manual

The following changes have been made to this manual (GFK-1411C) as compared to the previous version (GFK-1411B).

- Added an example in Chapter 2 (page 2-17) of the maximum number of nested calls for subroutine blocks allowed and text immediately before and after the example.
- I/O scan time contributions for the DSM314 motion control module have been added to Table 2-2 on page 2-5.
- DSM314 communications with the PLC has been added in Chapter 2 (page 2-11).
- A description of Local Logic Programs for the DSM314 motion control module has been included in Chapter 2 (page 2-39).
- Description of a new feature, Reboot After Fatal Failure, has been added in Section 1 of Chapter 3 (page 3-4).
- Other corrections and clarifications as needed.

Content of This Manual

- Chapter 1. Introduction:** provides an overview of the Series 90-30 PLCs.
- Chapter 2. System Operation:** describes PLC sweep, program organization and user references, power-up and power-down sequences, clocks and timers, system security, and other information about the Series 90-30 system.
- Chapter 3. Fault Explanation and Correction:** describes fault handling and both PLC and I/O fault table explanations.
- Appendix A. Instruction Timing:** lists the memory size in bytes and execution time in microseconds for each programming instruction.
- Appendix B. Interpreting Fault Tables:** describes how to interpret the message structure format when reading the fault tables.
- Appendix C. Using Floating-Point Numbers:** describes special considerations when using floating-point numbers.

Appendix D. Setting Up a Modem: describes how to set up 32-bit modem communications with your PLC using the Windows programming software and the Communications Configuration Utility (CCU)

Related Information

Manuals

<i>VersaPro User's Guide</i>	GFK-1670
<i>TCP/IP Ethernet Communications for the Series 90™ PLC</i>	GFK-1541
<i>Using Control Software</i>	GFK-1295
<i>Host Drivers and Communications Configuration Software for Windows® Environments</i>	GFK-1026
<i>C Programmer's Toolkit for Series 90 PLCs User's Manual</i>	GFK-0646
<i>Series 90™-30 PLC Installation and Hardware Manual</i>	GFK-0356

Other

GE Fanuc General Automation Online Support

<http://www.gefanuc.com/support/plc/default.htm>

GE Fanuc PLC Hotline Fax on Demand System (FaxLink) 804-978-5824

GE Fanuc PLC Hotline Telephone Number 1-800-GE Fanuc (1-800-433-2682)
International Customers direct dial: 804-978-6036

At GE Fanuc Automation, we strive to produce quality technical documentation. Please contact us with any comments you may have regarding this manual.

*Henry Konat
Technical Writer*

Chapter 1	Introduction.....	1-1
Chapter 2	System Operation.....	2-1
	Section 1: PLC Sweep Summary	2-2
	Standard Program Sweep	2-2
	Sweep Time Calculation.....	2-7
	Example of Sweep Time Calculation	2-7
	Housekeeping	2-7
	Input Scan.....	2-7
	Application Program Logic Scan or Solution	2-8
	Output Scan	2-8
	Logic Program Checksum Calculation.....	2-8
	Programmer Communications Window.....	2-9
	System Communications Window	2-10
	PCM Communications with the PLC (Models 331 and Higher).....	2-11
	DSM Communications with the PLC	2-11
	Standard Program Sweep Variations	2-12
	Constant Sweep Time Mode.....	2-12
	PLC Sweep When in STOP Mode	2-12
	Communication Window Modes.....	2-13
	Key Switch on 35x and 36x Series CPUs: Change Mode and Flash Protect	2-13
	Using the Release 7 and Later Key Switch.....	2-13
	Clearing the Fault Table with the Key Switch.....	2-14
	Enhanced Memory Protect with Release 8 and Later CPUs.....	2-14
	Section 2: Program Organization and User References/Data	2-15
	Subroutine Blocks.....	2-16
	Examples of Using Subroutine Blocks	2-16
	How Blocks Are Called.....	2-17
	Periodic Subroutines.....	2-18
	User References.....	2-19
	Transitions and Overrides	2-20
	Retentiveness of Data	2-20
	Data Types	2-21
	System Status References	2-22
	Function Block Structure	2-25
	Format of Ladder Logic Relays	2-25
	Format of Program Function Blocks	2-26
	Function Block Parameters	2-27
	Power Flow In and Out of a Function	2-28
	Section 3: Power-Up and Power-Down Sequences.....	2-29
	Power-Up	2-29
	Power-Down.....	2-31

	Section 4: Clocks and Timers.....	2-32
	Elapsed Time Clock.....	2-32
	Time-of-Day Clock.....	2-32
	Watchdog Timer	2-33
	Constant Sweep Timer	2-33
	Time-Tick Contacts	2-33
	Section 5: System Security	2-34
	Passwords.....	2-34
	Privilege Level Change Requests	2-34
	Locking/Unlocking Subroutines.....	2-35
	Permanently Locking a Subroutine.....	2-35
	Section 6: Series 90-30 I/O System.....	2-36
	Series 90-30 I/O Modules	2-37
	I/O Data Formats	2-39
	Default Conditions for Series 90-30 Output Modules	2-39
	Diagnostic Data	2-40
	Global Data	2-40
	Genius Global Data	2-40
	Ethernet Global Data	2-40
	Local Logic Programs	2-40
Chapter 3	Fault Explanation and Correction.....	3-1
	Section 1: Fault Handling	3-2
	Alarm Processor	3-2
	Classes of Faults	3-2
	System Reaction to Faults.....	3-3
	Fault Tables.....	3-3
	Fault Action	3-4
	Reboot After Fatal Fault.....	3-4
	Fault References	3-5
	Fault Reference Definitions	3-5
	Additional Fault Effects	3-5
	PLC Fault Table Display.....	3-6
	I/O Fault Table Display	3-6
	Accessing Additional Fault Information.....	3-7
	Section 2: PLC Fault Table Explanations	3-8
	Fault Actions	3-9
	Loss of, or Missing, Option Module.....	3-9
	Reset of, Addition of, or Extra, Option Module.....	3-9
	System Configuration Mismatch.....	3-10
	Option Module Software Failure.....	3-11

	Program Block Checksum Failure.....	3-11
	Low Battery Signal.....	3-11
	Constant Sweep Time Exceeded	3-12
	Application Fault.....	3-12
	No User Program Present	3-12
	Corrupted User Program on Power-Up	3-13
	Password Access Failure	3-13
	PLC CPU System Software Failure.....	3-14
	Communications Failure During Store.....	3-16
	Section 3: I/O Fault Table Explanations	3-17
	Loss of I/O Module.....	3-17
	Addition of I/O Module	3-18
Appendix A	Instruction Timing	A-1
	Instruction Timing Tables	A-2
	Instruction Sizes for High Performance CPUs.....	A-12
	Boolean Execution Times	A-12
Appendix B	Interpreting Fault Tables.....	B-1
	PLC Fault Table	B-2
	I/O Fault Table	B-8
Appendix C	Using Floating-Point Numbers	C-1
	Floating-Point Numbers.....	C-1
	Internal Format of Floating-Point Numbers.....	C-3
	Values of Floating-Point Numbers	C-4
	Entering and Displaying Floating-Point Numbers.....	C-5
	Errors in Floating-Point Numbers and Operations	C-6
Appendix D	Setting Up a Modem.....	D-1
	Modem Configuration and Cabling	D-1
	PLC CPU Configuration	D-2
	Installing the Modem into Windows.....	D-3
	Setting Up the Communications Configuration Utility (CCU).....	D-4
	Connecting to the PLC.....	D-6
	Using the HyperTerminal Utility to Establish Connection	D-7
	Other Issues.....	D-8

Contents

Figure 2-1. PLC Sweep	2-3
Figure 2-2. Programmer Communications Window Flow Chart.....	2-9
Figure 2-3. System Communications Window Flow Chart.....	2-10
Figure 2-4. PCM Communications with the PLC.....	2-11
Figure 2-5. Power-Up Sequence	2-30
Figure 2-6. Time-Tick Contact Timing Diagram.....	2-33
Figure 2-7. Series 90-30 I/O Structure	2-36
Figure 2-8. Series 90-30 I/O Modules	2-37

Table 2-1. Sweep Time Contribution	2-4
Table 2-2. I/O Scan Time Contributions for the Series 90-30 35x and 36x CPUs (in milliseconds).....	2-5
Table 2-3. I/O Scan Time Contributions for the Series 90-30 CPUs up to 341 (in milliseconds).....	2-6
Table 2-4. Register References	2-19
Table 2-5. Discrete References	2-19
Table 2-5. Discrete References - Continued	2-20
Table 2-6. Data Types	2-21
Table 2-7. System Status References	2-22
Table 2-7. System Status References - Continued	2-24
Table 2-7. System Status References - Continued	2-25
Table 2-8. Series 90-30 I/O Modules - Continued	2-38
Table 2-8. Series 90-30 I/O Modules - Continued	2-39
Table 3-1. Fault Summary	3-3
Table 3-2. Fault Actions	3-4
Table A-1. Instruction Timing, Standard Models	A-2
Table A-1. Instruction Timing, Standard Models-Continued	A-3
Table A-1. Instruction Timing, Standard Models-Continued	A-4
Table A-1. Instruction Timing, Standard Models-Continued	A-5
Table A-2. Instruction Timing, High Performance Models.....	A-6
Table A-2. Instruction Timing, High Performance Models-Continued.....	A-7
Table A-2. Instruction Timing, High Performance Models-Continued.....	A-8
Table A-2. Instruction Timing, High Performance Models-Continued.....	A-9
Table A-3. SER Function Block Timing	A-10
Table A-4. SER Function Block Trigger Timestamp Formats	A-11
Table A-5. Instruction Sizes for 350—352, 360, 363, and 364 CPUs	A-12
Table B-1. PLC Fault Groups	B-4
Table B-2. PLC Fault Actions	B-4
Table B-3. Alarm Error Codes for PLC CPU Software Faults	B-5
Table B-4. Alarm Error Codes for PLC Faults	B-6
Table B-5. PLC Fault Data - Illegal Boolean Opcode Detected	B-7
Table B-6. PLC Fault Time Stamp.....	B-7
Table B-7. I/O Fault Table Format Indicator Byte.....	B-9
Table B-8. I/O Reference Address	B-9
Table B-9. I/O Reference Address Memory Type	B-9
Table B-10. I/O Fault Groups	B-10
Table B-11. I/O Fault Actions	B-10

Contents

Table B-12. I/O Fault Specific Data.....	B-11
Table B-13. I/O Fault Time Stamp.....	B-11
Table C-1. General Case of Power Flow for Floating-Point Operations.....	C-7

Chapter 1

Introduction

The Series 90-30 PLCs are members of the GE Fanuc Series 90™ family of Programmable Logic Controllers (PLCs). They are easy to install and configure, offer advanced programming features, and are compatible with the Series 90-70 PLCs.

Two Windows-based configuration/programming packages are available for Series 90-30 PLCs. VersaPro software supports all Series 90-30 CPUs. Control software supports the 35x and 36x series CPUs.

The software structure for the 341 and lower Series 90-30 PLCs uses an architecture that manages memory and execution priority in the 80188 microprocessor. The 35x and 36x series of Series 90-30 PLCs use an 80386EX microprocessor. This operation supports both program execution and basic housekeeping tasks such as diagnostic routines, input/output scanners, and alarm processing. The system software also contains routines to communicate with the programmer. These routines provide for the upload and download of application programs, return of status information, and control of the PLC.

In the Series 90-30 PLC, a dedicated Instruction Sequencer Coprocessor (ISCP) controls the application (user logic) program that controls the end process to which the PLC is applied. The ISCP is implemented in hardware in the Model 313 and higher and in software in the Model 311 systems. The 80188 microprocessor and the ISCP can execute simultaneously, allowing the microprocessor to service communications while the ISCP is executing the bulk of the application program; however, the microprocessor must execute the non-Boolean function blocks. Faults occur in the Series 90-30 PLC when certain failures or conditions happen that affect the operation and performance of the system. These conditions may affect the ability of the PLC to control a machine or process. Other conditions may only act as an alert, such as a low battery signal to indicate that the voltage of the battery protecting the memory is low and should be replaced. The condition or failure is called a fault.

Faults are handled by a software alarm processor function that records the faults in either the PLC fault table or the I/O fault table. (Model 331 and higher CPUs also time-stamp the faults.) These tables can be displayed through the programming software.

Note

Floating-point capabilities are *only* supported on the 35x and 36x series CPUs, Release 9 or later, and on all releases of CPU352.

Note

For additional information, see the appendices in the back of this manual.

- Appendix A lists the memory size in bytes and the execution time in microseconds for each programming instruction.
- Appendix B describes how to interpret the message structure format when reading the PLC and I/O fault tables.
- Appendix C describes special considerations for using floating point functions.
- Appendix D describes how to set up modem communications.

Chapter 2

System Operation

This chapter describes certain system operations of the Series 90-30 PLC systems. These system operations include:

- A summary of PLC sweep sequences (Section 1) 2-2
- Program organization and user references/data (Section 2) 2-15
- Power-up and power-down sequences (Section 3) 2-28
- Clocks and timers (Section 4) 2-31
- System security through password assignment (Section 5) 2-33
- Series 90-30 I/O system (Section 6) 2-35

Section 1: *PLC Sweep Summary*

The logic program in the Series 90-30 PLCs execute repeatedly until stopped by a command from the programmer or a command from another device. The sequence of operations necessary to execute a program one time is called a sweep. In addition to executing the logic program, the sweep includes obtaining data from input devices, sending data to output devices, performing internal housekeeping, servicing the programmer, and servicing other communications.

Series 90-30 PLCs normally operate in **STANDARD PROGRAM SWEEP** mode. Other operating modes include **STOP WITH I/O DISABLED** mode, **STOP WITH I/O ENABLED** mode, and **CONSTANT SWEEP** mode. Each of these modes, described in this chapter, is controlled by external events and application configuration settings. The PLC makes the decision regarding its operating mode at the start of every sweep.

Standard Program Sweep

STANDARD PROGRAM SWEEP mode normally runs under all conditions. The CPU operates by executing an application program, updating I/O, and performing communications and other tasks. This occurs in a repetitive cycle called the CPU sweep. There are seven parts to the execution sequence of the Standard Program Sweep:

1. Start-of-sweep housekeeping
2. Input scan (read inputs)
3. Application program logic solution
4. Output scan (update outputs)
5. Programmer service
6. Non-programmer service
7. Diagnostics

All of these steps execute every sweep. Although the Programmer Communications Window opens each sweep, programmer services only occur if a board fault has been detected or if the programming device issues a service request; that is, the Programmer Communications Window first checks for work to do and exits if there is none. The sequence of the standard program sweep is shown in the following figure.

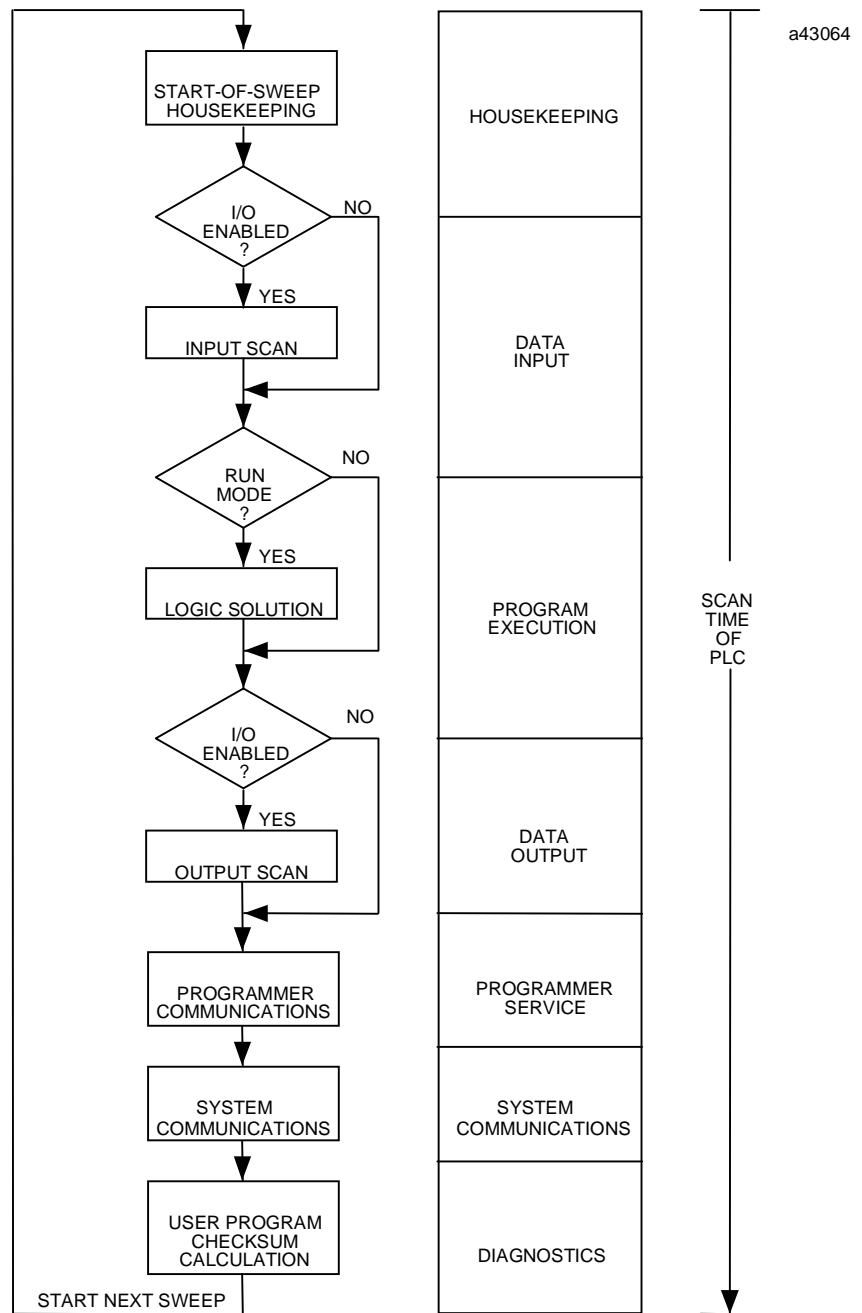

Figure 2-1. PLC Sweep

As shown in the PLC sweep sequence, several items are included in the sweep. These items contribute to the total sweep time as shown in the following table.

Table 2-1. Sweep Time Contribution

Sweep Element	Description	Time Contribution (ms) ⁴				
		311/313	331	340/341	351/352 (35x and 36x) ⁵	
Housekeeping	<ul style="list-style-type: none"> Calculate sweep time. Schedule start of next sweep. Determine mode of next sweep. Update fault reference tables. Reset watchdog timer. 	0.714	0.705	0.424	0.279	
Data Input	Input data is received from input and option modules.	See tables 2-2 and 2-3 for scan time contributions.				
Program Execution	User logic is solved.	Execution time is dependent upon the length of the program and the type of instructions used in the program. Instruction execution times are listed in Appendix A.				
Data Output	Output data is sent to output and option modules.	See tables 2-2 and 2-3 for scan time contributions.				
Service External Devices	Service requests from programming devices and intelligent modules are processed. ¹	HHP	4.426	4.524	2.476	0.334
		LM90	2.383	2.454	1.248	0.517
		PCM ²	N/A	3.337	1.943	0.482
Reconfiguration	Slots with faulted modules and empty slots are monitored.	0.458	0.639	0.463	0.319	
Diagnostics	Verify user program integrity (time contribution is the time required per word checksummed each sweep). ³	0.050	0.048	0.031	0.010	

1. The scan time contribution of external device service is dependent upon the mode of the communications window in which the service is processed. If the window mode is LIMITED, a maximum of 8 milliseconds for the 311, 313, 323, and 331 CPUs and 6 milliseconds for the 340 and higher CPUs will be spent during that window. If the window mode is RUN-TO-COMPLETION, a maximum of 50 milliseconds can be spent in that window, depending upon the number of requests which are presented simultaneously.
2. These measurements were taken with the PCM physically present but not configured and with no application task running on the PCM.
3. The number of words checksummed each sweep can be changed with the SVCREQ function block.
4. These measurements were taken with an empty program and the default configuration. The Series 90-30 PLCs were in an empty 10-slot rack with no extension racks connected. Also, the times in this table assume that there is no periodic subroutine active; the times will be larger if a periodic subroutine is active.
5. The times for the 350 CPU and the 36x series are estimated to be the same.

Table 2-2. I/O Scan Time Contributions for the Series 90-30 35x and 36x CPUs (in milliseconds)

Module Type		35x and 36x Series CPUs		
		Main Rack	Expansion Rack	Remote Rack
8-point discrete input		.030	.055	.206
16-point discrete input		.030	.055	.206
32-point discrete input		.043	.073	.269
8-point discrete output		.030	.053	.197
16-point discrete output		.030	.053	.197
32-point discrete output		.042	.070	.259
Combination discrete input/output		.060	.112	.405
4-channel analog input		.075	.105	.396
2-channel analog output		.058	.114	.402
16-channel analog input (current or voltage)		.978	1.446	3.999
8-channel analog output		1.274	1.988	4.472
Combination analog input/output		1.220	1.999	4.338
High Speed Counter		1.381	2.106	5.221
I/O Processor		1.574	2.402	6.388
Ethernet Interface (no connection)		.038	.041	.053
Power Mate APM (1-axis)		1.527	2.581	6.388
Power Mate APM (2-axis)		1.807	2.864	7.805
DSM 302	40 AI, 6 AQ	2.143	3.315	9.527
	50 AI, 9 AQ	2.427	3.732	11.092
	64 AI, 12 AQ	2.864	4.317	13.138
DSM 314 (not supported by CPU351)	1 Axis	1.6	2.6	6.9
	2 Axes	2.2	3.8	9.9
	3 Axes	2.8	4.3	13.0
	4 Axes	3.3	5.2	15.9
GCM	no devices	.911	1.637	5.020
	8 64-word devices	8.826	16.932	21.179
GCM+	no devices	.567	.866	1.830
	32 64-word devices	1.714	2.514	5.783
GBC	no devices	.798	1.202	2.540
	32 64-word devices	18.382	25.377	70.777
PCM 311	not configured, or no application task	.476	N/A	N/A
	read 128 %R as fast as possible	.485	N/A	N/A
	ADC (no task)	.476	N/A	N/A
I/O Link Master	no devices	.569	.865	1.932
	16 64-point devices	4.948	7.003	19.908
I/O Link Slave	32-point	.087	.146	.553
	64-point	.154	.213	.789

Table 2-3. I/O Scan Time Contributions for the Series 90-30 CPUs up to 341 (in milliseconds)

Module Type		CPU Model						
		311/313	331			340/341		
			Main Rack	Expansion Rack	Remote Rack	Main Rack	Expansion Rack	Remote Rack
8point discrete input		.076	.054	.095	.255	.048	.089	.249
16point discrete input		.075	.055	.097	.257	.048	.091	.250
32point discrete input		.094	.094	.126	.335	.073	.115	.321
8point discrete output		.084	.059	.097	.252	.053	.090	.246
16point discrete output		.083	.061	.097	.253	.054	.090	.248
32point discrete output		.109	.075	.129	.333	.079	.114	.320
8point combination input/output		.165	.141	.218	.529	.098	.176	.489
4channel analog input		.151	.132	.183	.490	.117	.160	.462
2channel analog output		.161	.138	.182	.428	.099	.148	.392
High Speed Counter		2.070	2.190	2.868	5.587	1.580	2.175	4.897
Power Mate APM (1axis)		2.330	2.460	3.175	6.647	1.750	2.506	5.899
Power Mate APM (2axis)		3.181	3.647	4.497	9.303	2.154	3.097	7.729
DSM 302	40 AI, 6 AQ	3.613	4.081	5.239	11.430	2.552	3.648	9.697
	50AI, 9 AQ	4.127	4.611	5.899	13.310	2.911	4.170	11.406
	64 AI, 12 AQ	4.715	5.276	6.759	15.747	3.354	4.840	13.615
GCM	no devices	.041	.054	.063	.128	.038	.048	.085
	8 64point devices	11.420	11.570	13.247	21.288	9.536	10.648	19.485
GCM+	no devices	.887	.967	1.164	1.920	.666	.901	1.626
	32 64point devices	4.120	6.250	8.529	21.352	5.043	7.146	20.052
PCM 311	not configured, or no application task	N/A	3.350	N/A	N/A	1.684	N/A	N/A
	read 128 %R as fast as possible	N/A	4.900	N/A	N/A	2.052	N/A	N/A
ADC 311		N/A	3.340	N/A	N/A	1.678	N/A	N/A
16channel analog input (current or voltage)		1.370	1.450	1.937	4.186	1.092	1.570	3.796
I/O Link Master	no devices	1.910	2.030	1.169	1.925	.678	.904	1.628
	sixteen 64point devices	6.020	6.170	8.399	21.291	4.992	6.985	20.010
I/O Link Slave	32point	.206	.222	.289	.689	.146	.226	.636
	64point	.331	.350	.409	1.009	.244	.321	.926

Sweep Time Calculation

Table 2-1 lists the seven items that contribute to the sweep time of the PLC. The sweep time consists of fixed times (housekeeping and diagnostics) and variable times. Variable times vary according to the I/O configuration, size of the user program, and the type of programming device connected to the PLC.

Example of Sweep Time Calculation

An example of the calculations for determining the sweep time for a Series 90-30 model 331 PLC are shown in the table shown below.

The modules and instructions used for these calculations are listed below:

- Input modules: five 16-point Series 90-30 input modules.
- Output modules: four 16-point Series 90-30 output modules.
- Programming instructions: A 1200-step program consisting of 700 Boolean instructions (LD, AND, OR, etc.), 300 output coils (OUT, OUTM, etc.), and 200 math functions (ADD, SUB, etc.).

Housekeeping

The housekeeping portion of the sweep performs all of the tasks necessary to prepare for the start of the sweep. If the PLC is in **CONSTANT SWEEP** mode, the sweep is delayed until the required sweep time elapses. If the required time has already elapsed, the OV_SWP %SA0002 contact is set, and the sweep continues without delay. Next, timer values (hundredths, tenths, and seconds) are updated by calculating the difference from the start of the previous sweep and the new sweep time. In order to maintain accuracy, the actual start of sweep is recorded in 100 microsecond increments. Each timer has a remainder field which contains the number of 100 microsecond increments that have occurred since the last time the timer value was incremented.

Input Scan

Scanning of inputs occurs during the input scan portion of the sweep, just prior to the logic solution. During this part of the sweep, all Series 90-30 input modules are scanned and their data stored in %I (discrete inputs) or %AI (analog inputs) memory, as appropriate. Any global data input received by a Genius Communications Module, an Enhanced Genius Communications Module, or a Genius Bus Controller is stored in %G memory.

Modules are scanned in ascending reference address order, starting with the Genius Communications Module, then discrete input modules, and finally analog input modules.

If the CPU is in **STOP** mode and the CPU is configured to not scan I/O in **STOP** mode, the input scan is skipped.

Application Program Logic Scan or Solution

The application program logic scan is when the application logic program actually executes. The logic solution always begins with the first instruction in the user application program immediately following the completion of the input scan. Solving the logic provides a new set of outputs. The logic solution ends when the END instruction is executed (the END is invisible unless you are using a Hand-Held Monitor).

The ISCP and the 80C188 microprocessor execute the application program. In the model 313 and higher CPUs, the ISCP executes the Boolean instructions; and the 80C188 or 80386EX executes the timer, counter, and function blocks. In the model 311 CPUs, the 80C188 executes all Boolean, timer, counter, and function block instructions.

A list of execution times for each programming function can be found in Appendix A.

Output Scan

Outputs are scanned during the output scan portion of the sweep, immediately following the logic solution. Outputs are updated using data from %Q (for discrete outputs) and %AQ (for analog outputs) memory, as appropriate. If the Genius Communications Module is configured to transmit global data, then data from %G memory is sent to the GCM, GCM+, or GBC.

During the output scan, all Series 90-30 output modules are scanned in ascending reference address order.

If the CPU is in the **STOP** mode and the CPU is configured to not scan I/O during **STOP** mode, the output scan is skipped. The output scan is completed when all output data has been sent to all Series 90-30 output modules.

Logic Program Checksum Calculation

A checksum calculation is performed on the user program at the end of every sweep. Since it would take too long to calculate the checksum of the entire program, you can specify the number of words from 0 to 32 to be checked on the CPU detail screen.

If the calculated checksum does not match the reference checksum, the program checksum failure exception flag is raised. This causes a fault entry to be inserted into the PLC fault table and the PLC mode to be changed to **STOP**. If the checksum calculation fails, the programmer communications window is not affected. The default number of words to be checksummed is 8.

Programmer Communications Window

This part of the sweep is dedicated to communicating with the programmer. If there is a programmer attached, the CPU executes the programmer communications window. The programmer communications window will not execute if there is no programmer attached and no board to be configured in the system. Only one board is configured each sweep.

Support is provided for the Hand-Held Programmer and for other programmers that can connect to the serial port and use the Series Ninety Protocol (SNP) protocol. Support is also provided for programmer communications with intelligent option modules.

In the default limited window mode, the CPU performs one operation for the programmer each sweep, that is, it honors one service request or response to one key press. If the programmer makes a request that requires more than 6 (or 8 depending on the CPU - see Note) milliseconds to process, the request processing is spread out over several sweeps so that no sweep is impacted by more than 6 (or 8 depending on the CPU - see Note) milliseconds.

Note

The time limit for the communications window is 6 milliseconds for the model 340 and higher CPUs and 8 milliseconds for the 311, 313, 323, and 331 models.

The following figure is a flow chart for the programmer communications portion of the sweep.

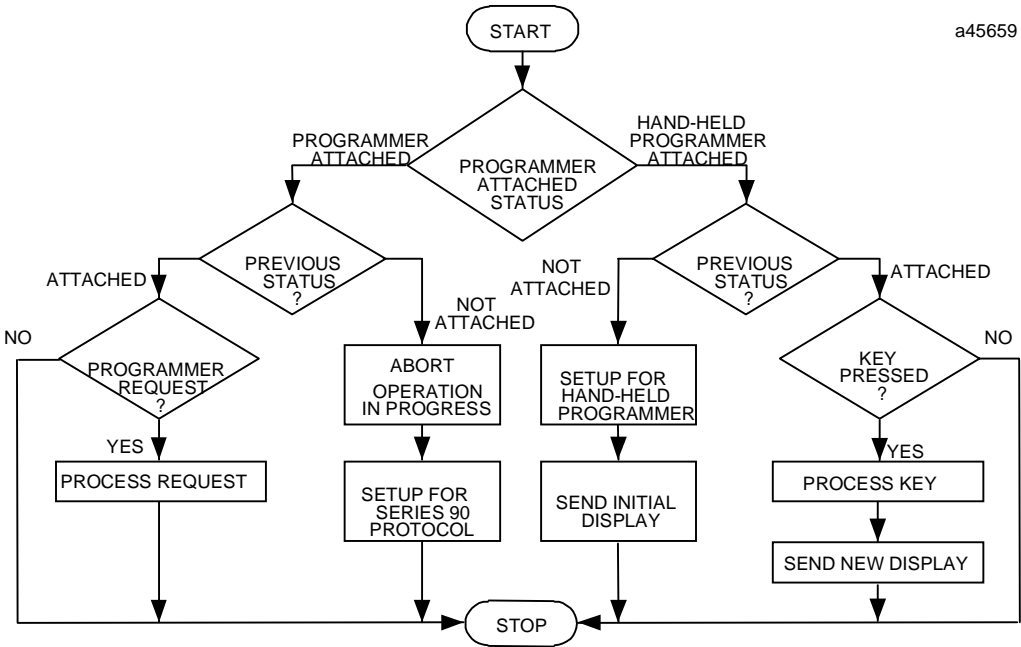

Figure 2-2. Programmer Communications Window Flow Chart

System Communications Window

This is the part of the sweep where communications requests from intelligent option modules, such as the PCM or DSM, are processed (see flow chart). Requests are serviced on a first-come-first-served basis. However, since intelligent option modules are polled in a round-robin fashion, no intelligent option module has priority over any other intelligent option module.

In the default **Run-to-Completion** mode, the length of the system communications window is limited to 50 milliseconds. If an intelligent option module makes a request that requires more than 50 milliseconds to process, the request is spread out over multiple sweeps so that no one sweep is impacted by more than 50 milliseconds.

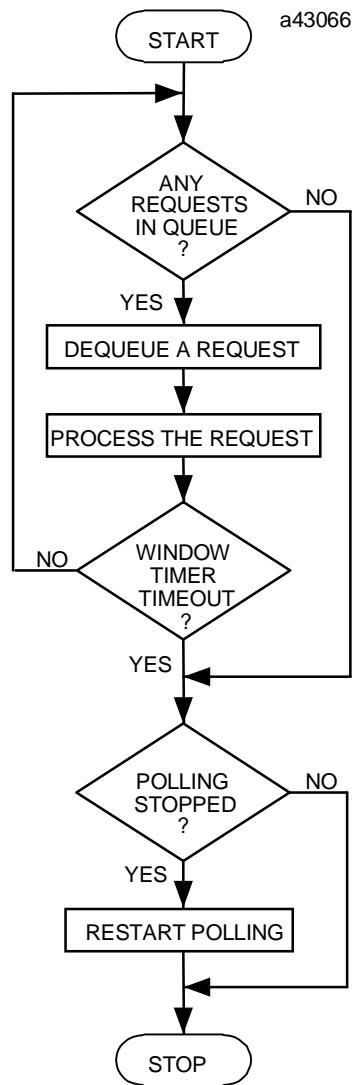

Figure 2-3. System Communications Window Flow Chart

PCM Communications with the PLC (Models 331 and Higher)

There is no way for intelligent option modules (IOM), such as the PCM, to interrupt the CPU when they need service. The CPU must poll each intelligent option module for service requests. This polling occurs asynchronously in the background during the sweep (see flow chart below).

When an intelligent option module is polled and sends the CPU a service request, the request is queued for processing during the system communications window.

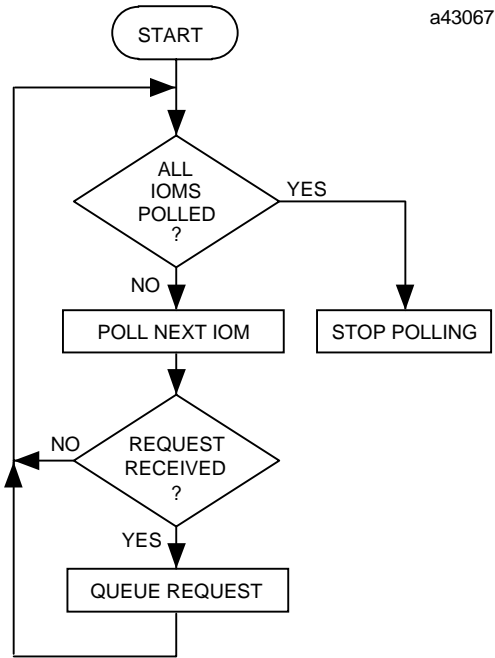

Figure 2-4. PCM Communications with the PLC

DSM Communications with the PLC

The DSM302 and DSM314 are intelligent motion control modules operating asynchronously with the Series 90-30 CPU module. Data is exchanged between the CPU and the DSM modules automatically.

The DSM302 can be configured for three different lengths of %AI and %AQ data. A PLC CPU requires time to read and write the data across the backplane with the DSM302. Tables 2-2 and 2-3 list the sweep impact for the different configurations of %AI and %AQ data for the DSM302. For additional timing considerations that apply to the DSM302 module, refer to the *Motion Mate DSM302 for Series 90-30 PLCs User's Manual*, GFK-1464.

The length of %AI and %AQ data in the DSM314 is automatically assigned according to the number of axes selected (1 to 4). Table 2-2 lists the sweep impact for the different number of axes for the DSM314. Note that only 35x (except CPU351) and 36X CPUs support the DSM 314. For additional timing considerations that apply to the DSM314 module, refer to the *Motion Mate DSM314 for Series 90-30 PLCs User's Manual*, GFK-1741.

Standard Program Sweep Variations

In addition to the normal execution of the standard program sweep, certain variations can be encountered or forced. These variations, described in the following paragraphs, can be displayed and/or changed from the programming software.

Constant Sweep Time Mode

In the standard program sweep, each sweep executes as quickly as possible with a varying amount of time consumed each sweep. An alternative to this is **CONSTANT SWEEP TIME** mode, where each sweep consumes the same amount of time. You can achieve this by setting the Configured Constant Sweep, which will then become the default sweep mode, thereby taking effect each time the PLC goes from **STOP** to **RUN** mode. A value from 5 to 200 milliseconds (or up to 500 milliseconds for the 35x and 36x series PLC CPUs) for the constant sweep timer (default is 100 milliseconds) is supported.

Due to variations in the time required for various parts of the PLC sweep, the constant sweep time should be set at least 10 milliseconds higher than the sweep time that is displayed on the status line when the PLC is in **NORMAL SWEEP** mode. This prevents the occurrence of extraneous oversweep faults.

Use a constant sweep when I/O points or register values must be polled at a constant frequency, such as in control algorithms. One reason for using **CONSTANT SWEEP TIME** mode might be to ensure that I/O are updated at constant intervals. Another reason might be to ensure that a certain amount of time elapses between the output scan and the next sweep's input scan, permitting inputs to settle after receiving output data from the program.

If the constant sweep timer expires before the sweep completes, the entire sweep, including the windows, is completed. However, an oversweep fault is logged at the beginning of the next sweep.

Note

Unlike the Active Constant Sweep which can be edited only in **RUN** mode, the Configured Constant Sweep Mode can be edited only during **STOP** mode and you must "Store the configuration from the Programmer to the PLC" before the change will take effect. Once stored, this becomes the default sweep mode.

PLC Sweep When in STOP Mode

When the PLC is in **STOP** mode, the application program is not executed. Communications with the programmer and intelligent option modules continue. In addition, faulted board polling and board reconfiguration execution continue while in **STOP** mode. For efficiency, the operating system uses larger time-slice values than those used in **RUN** mode (usually about 50 milliseconds per window). You can choose whether or not the I/O is scanned. I/O scans may execute in **STOP** mode if the **IOScan-Stop** parameter on the CPU detail screen is set to **YES**.

Communication Window Modes

The default window mode for the programmer communication window is “Limited” mode. That means that if a request takes more than 6 milliseconds to process, it is processed over multiple sweeps, so that no one sweep is impacted by more than 6 milliseconds. For the 313, 323, and 331 CPUs, the sweep impact may be as much as 12 milliseconds during a **RUN**-mode store. Refer to the online help for instructions on changing the active mode within Control software.

Note

If the system window mode is changed to Limited, then option modules such as the PCM or GBC that communicate with the PLC using the system window will have less impact on sweep time, but response to their requests will be slower.

Key Switch on 35x and 36x Series CPUs: Change Mode and Flash Protect

Each of the 35x and 36x series CPUs has a key switch on the front of the module that allows you to protect Flash memory from being over-written. When you turn the key to the **ON/RUN** position, no one can change the Flash memory without turning the key to the OFF position.

Beginning with Release 7 of the 351 and 352 CPUs, the Key Switch has another function: it allows you to switch the PLC into **STOP** mode, into **RUN** mode, and to clear non-fatal faults as discussed in the next section.

Beginning with Release 8 of the 35x and the 36x series CPUs, the Key Switch has an enhanced memory protection function: it can be used to provide two additional types of memory protection (see the “Using the Release 8 and Later Memory Protection” section).

If the key switch is enabled and in the **ON/RUN** position, you can change the Time of Day clock only through the programming software. The Hand Held Programmer does not allow you to change the Time of Day clock while key switch protection is active.

Using the Release 7 and Later Key Switch

Unlike the Flash Protection capabilities in the earlier release, if you do not enable the Key Switch through the **RUN/STOP** Key Switch parameter in the CPU’s configuration screen, the CPU does not have the enhanced control discussed here.

The operation of the Key Switch has the same safeguards and checks before the PLC goes to **RUN** mode just like the existing transition to **RUN** mode; that is, the PLC will not go to **RUN** mode via Key Switch input when the PLC is in **STOP/FAULT** mode. However, in the **STOP/FAULT** mode, you can clear non-fatal faults and put the PLC in **RUN** mode through the use of the Key Switch.

If there are faults in the fault tables that *are not fatal* (that is, they do not cause the CPU to be placed in the **STOP/FAULT** mode), then the CPU will be placed in **RUN** mode the first time you turn the key from Stop to Run, and the fault tables will NOT be cleared.

If there are faults in the fault table that *are fatal* (CPU in **STOP/FAULT** mode), then the first transition of the Key Switch from the **STOP** position to the **RUN** position will cause the CPU **RUN** light to begin to flash at 2 Hz rate and a 5 second timer will begin. The flashing **RUN** light is an indication that there are fatal fault(s) in the fault tables. In which case, the CPU will NOT be placed in the **RUN** state even though the Key Switch is in **RUN** position.

Clearing the Fault Table with the Key Switch

If you turn the key from the **RUN** to **STOP** and back to **RUN** position during the 5 seconds when the **RUN** light is flashing this will cause the faults to be cleared and the CPU will be placed into **RUN** mode. The light will stop flashing and will go solid **ON** at this point. The switch is required to be kept in either **RUN** or **STOP** position for at least 1/2 second before switching back to the other position.

Note

If you allow the 5 second timer to expire (**RUN** light stops flashing) the CPU will remain in its original state, **STOP/FAULT** mode, with faults in the fault table. If you turn the Key Switch from the **STOP** to **RUN** position again at this time, the process will be repeated with this being the first transition.

The following table provides a summary of how the two CPU parameter settings affecting the Key Switch (R/S Switch and IOScan-Stop) and the Key Switch's physical position affect PLC.

R/S Key Switch Parameter in CPU Configuration	Key Switch Position	IOScan-Stop Parameter in CPU Configuration	PLC Operation
OFF	X	X	All PLC Programmer Modes are allowed.
ON	ON/RUN	X	All PLC Programmer Modes are allowed.
ON	OFF/STOP	X	PLC not allowed to go to RUN.
ON	Toggle Key Switch from OFF/STOP to ON/RUN	X	PLC goes to RUN if no fatal faults are present; otherwise, the RUN LED blinks for 5 seconds.
ON	Toggle Key Switch from ON/RUN to OFF/STOP	NO	PLC goes to STOP-NO IO
ON	Toggle Key Switch from ON/RUN to OFF/STOP	YES	PLC goes to STOP-IO

X = Has no effect regardless of setting

Enhanced Memory Protect with Release 8 and Later CPUs

In the Release 8 and later CPUs, the Key Switch has all the functionality discussed above, plus, by setting a parameter in the programming package, it can be used to protect RAM so that the RAM cannot be changed from the programming software. Two types of operations are blocked when this memory protection is enabled: the user program and configuration cannot be modified and the force and override of point data is not allowed. This is activated through the Memory Protect field in the Settings tab for the 35x or 36x series CPUs module in Hardware Configuration within VersaPro or Control software. The default is Disabled.

Section 2: Program Organization and User References/Data

The total logic size for the Series 90-30 programmable controllers is listed in the following table.

Models	User Logic Memory (Kbytes)
CPU311	6
CPU313, CPU323	12
CPU331	16
CPU340	32
CPU341	80
CPU350	80 (release 9 and later) 32 (prior to release 9)
CPU351, CPU352, CPU360, CPU363, CPU364	240 (release 9 and later) 80 (prior to release 9)

Beginning with Release 9 CPUs, some memory sizes for the 351, 352 and 36x series are configurable. (For detailed instructions and a discussion of memory sizes available, refer to the online help within Control or VersaPro software. The user program contains logic that is used when it is started up. The maximum number of rungs allowed per logic block (main or subroutine) is 3000; the maximum block size is 80 kilobytes for C blocks and 16 kilobytes for LD and SFC blocks, but in an SFC block some of the 16 KB is used for the internal data block. The logic is executed repeatedly by the PLC.

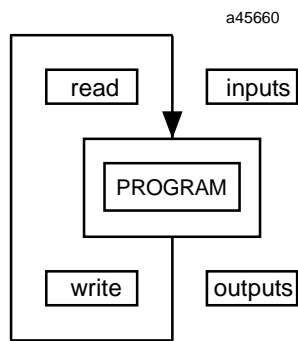

Refer to the *Series 90-30 PLC Installation and Hardware Manual*, GFK-0356, for a listing of program sizes and reference limits for each model CPU.

All programs have a variable table that lists the variable and reference descriptions that have been assigned in the user program.

The block declaration editor lists subroutine blocks declared in the main program.

Subroutine Blocks

A program can “call” subroutine blocks as it executes. A maximum of 64 subroutine block declarations in the program and 64 CALL instructions are allowed for each logic block in the program. The maximum size of a subroutine block is 16 KB or 3000 rungs, but the main program and all subroutines must fit within the logic size constraints for that CPU model.

The use of subroutines is optional. Dividing a program into smaller subroutines can simplify programming, enhance understanding of the control algorithm, and reduce the overall amount of logic needed for the program.

Examples of Using Subroutine Blocks

As an example, the logic for a program could be divided into three subroutines, each of which could be called as needed from the program. In this example, the program block might contain little logic, serving primarily to sequence the subroutine blocks.

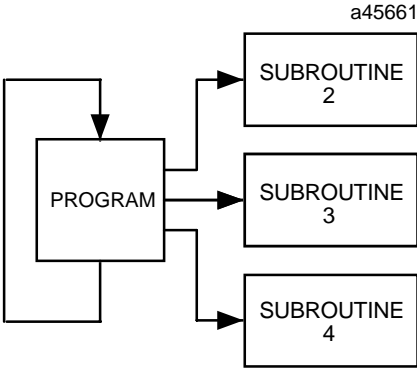

A subroutine block can be used many times as the program executes. Logic which needs to be repeated several times in a program could be entered in a subroutine block. Calls would then be made to that subroutine block to access the logic. In this way, total program size is reduced.

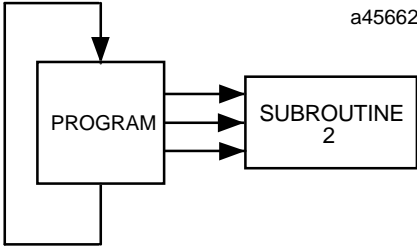

In addition to being called from the program, subroutine blocks can also be called by other subroutine blocks. A subroutine block may even call itself.

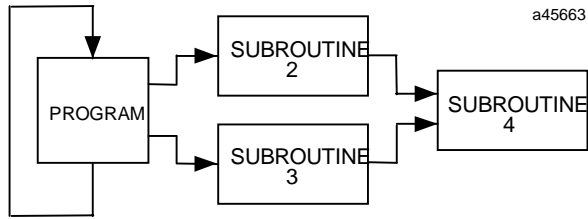

The PLC will only allow eight nested calls before an “Application Stack Overflow” fault is logged and the PLC transitions to **STOP/FAULT** mode. The call from the MAIN program to the first subroutine block counts as the first call. Subsequent calls may go seven more blocks deeper without an error. The following illustration shows the maximum call depth allowed at runtime.

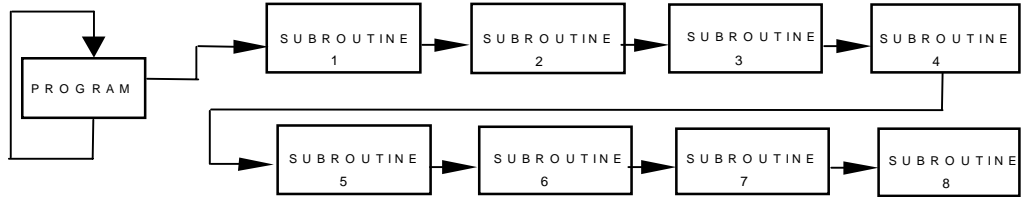

If subroutine 8 were to execute another call, the PLC would immediately transition to **STOP/FAULT** mode.

How Blocks Are Called

A subroutine block executes when called from the program logic in the program or from another block.

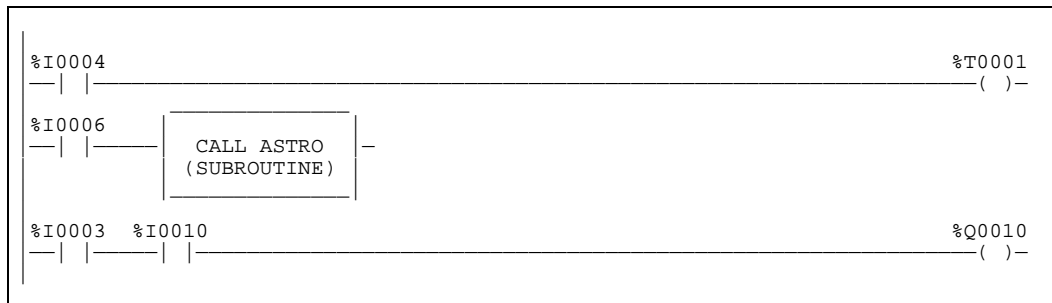

This example shows the subroutine CALL instruction as it will appear in the calling block.

Periodic Subroutines

Version 4.20 or later of the 340 and higher CPUs support periodic subroutines. Please note the following restrictions:

1. Timer (TMR, ONDTR, and OFDTR) function blocks will not execute properly within a periodic subroutine. A DOIO function block within a periodic subroutine whose reference range includes references assigned to a Smart I/O Module (HSC, Motion Mate APM, Motion Mate DSM, Genius, and others) will cause the CPU to lose communication with the module. The FST_SCN and LST_SCN contacts (%S1 and %S2) will have an indeterminate value during execution of the periodic subroutine. A periodic subroutine cannot call or be called by other subroutines.
2. The latency for the periodic subroutine (that is, the maximum interval between the time the periodic subroutine should have executed and the time it actually executes) can be around .35 milliseconds if there is no PCM, CMM, or ADC module in the main rack. If there is a PCM, CMM or ADC module in the main rack - even if it is not configured or used, the latency can be almost 2.25 milliseconds. For that reason, use of the periodic subroutine with PCM-based products is *not* recommended.

User References

The data used in an application program is stored as either register or discrete references.

Table 2-4. Register References

Type	Description
%R	The prefix %R is used to assign system register references, which will store program data such as the results of calculations.
%AI	The prefix %AI represents an analog input register. This prefix is followed by the register address of the reference (for example, %AI0015). An analog input register holds the value of one analog input or other value.
%AQ	The prefix %AQ represents an analog output register. This prefix is followed by the register address of the reference (for example, %AQ0056). An analog output register holds the value of one analog output or other value.

Note

All register references are retained across a power cycle to the CPU.

Table 2-5. Discrete References

Type	Description
%I	The %I prefix represents input references. This prefix is followed by the reference's address in the input table (for example, %I00121). %I references are located in the input status table, which stores the state of all inputs received from input modules during the last input scan. A reference address is assigned to discrete input modules using the configuration software or the Hand-Held Programmer. Until a reference address is assigned, no data will be received from the module. %I data can be retentive or non-retentive.
%Q	The %Q prefix represents physical output references. The %Q prefix is followed by the reference's address in the output table (for example, %Q00016). %Q references are located in the output status table, which stores the state of the output references as last set by the application program. This output status table's values are sent to output modules during the output scan. A reference address is assigned to discrete output modules using the configuration software or the Hand-Held Programmer. Until a reference address is assigned, no data is sent to the module. A particular %Q reference may be either retentive or non-retentive. *
%M	The %M prefix represents internal references. The coil check function checks for multiple uses of %M references with relay coils or outputs on functions. A particular %M reference may be either retentive or non-retentive. *
%T	The %T prefix represents temporary references. These references are never checked for multiple coil use and can, therefore, be used many times in the same program even when coil use checking is enabled. %T may be used to prevent coil use conflicts while using the cut/paste and file write/include functions. Because this memory is intended for temporary use, it is never retained through power loss or RUN-TO-STOP-TO-RUN transitions and cannot be used with retentive coils.

* Retentiveness is based on the type of coil. For more information, refer to "Retentiveness of Data" on page 2-20.

Table 2-5. Discrete References - Continued

Type	Description
%S	<p>The %S prefix represents system status references. These references are used to access special PLC data, such as timers, scan information, and fault information. System references include %S, %SA, %SB, and %SC references.</p> <p>%S, %SA, %SB, and %SC can be used on any contacts.</p> <p>%SA, %SB, and %SC can be used on retentive coils $-(M)-$.</p> <p>%S can be used as word or bit-string input arguments to functions or function blocks.</p> <p>%SA, %SB, and %SC can be used as word or bit-string input or output arguments to functions and function blocks.</p>
%G	<p>The %G prefix represents global data references. These references are used to access data shared among several PLCs. %G references can be used on contacts and retentive coils because %G memory is always retentive. %G cannot be used on non-retentive coils.</p>

Transitions and Overrides

The %I, %Q, %M, and %G user references have associated transition and override bits. %T, %S, %SA, %SB, and %SC references have transition bits, but not override bits. The CPU uses transition bits for counters and transitional coils. Note that counters do not use the same kind of transition bits as coils. Transition bits for counters are stored within the locating reference.

In the Model 331 and higher CPUs, override bits can be set. When override bits are set, the associated references cannot be changed from the program or the input device; they can only be changed on command from the programmer. CPU Models 323, 321, 313, and 311 do not support overriding discrete references.

Retentiveness of Data

Data is said to be retentive if it is saved by the PLC when the PLC is stopped. The Series 90 PLC preserves program logic, fault tables and diagnostics, overrides and output forces, word data (%R, %AI, %AQ), bit data (%I, %SC, %G, fault bits and reserved bits), %Q and %M data (unless used with non-retentive coils), and word data stored in %Q and %M. %T data is not saved. Although, as stated above, %SC bit data is retentive, the defaults for %S, %SA, and %SB are non-retentive.







%Q and %M references are non-retentive (that is, cleared at power-up when the PLC switches from **STOP** to **RUN**) whenever they are used with non-retentive coils. Non-retentive coils include coils $-()-$, negated coils $-(/)-$, SET coils $-(S)-$, and RESET coils $-(R)-$.

When %Q or %M references are used with retentive coils, or are used as function block outputs, the contents are retained through power loss and **RUN-TO-STOP-TO-RUN** transitions. Retentive coils include retentive coils $-(M)-$, negated retentive coils $-(/ M)-$, retentive SET coils $-(SM)-$, and retentive RESET coils $-(RM)-$.

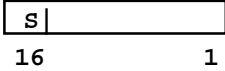
The last time a %Q or %M reference is programmed on a coil instruction determines whether the %Q or %M reference is retentive or non-retentive based on the coil type. For example, if %Q0001 was last programmed as the reference of a retentive coil, the %Q0001 data will be retentive. However, if %Q0001 was last programmed on a non-retentive coil, then the %Q0001 data will be non-retentive.

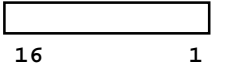
Data Types

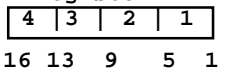
Table 2-6. Data Types

Type	Name	Description	Data Format
INT	Signed Integer	Signed integers use 16-bit memory data locations, and are represented in 2's complement notation. The valid range of an INT data type is -32,768 to +32,767.	<p>Register 1</p>  <p>(16 bit positions)</p>
DINT	Double Precision Signed Integer	Double precision signed integers are stored in 32-bit data memory locations (actually two consecutive 16-bit memory locations) and represented in 2's complement notation. (Bit 32 is the sign bit.) The valid range of a DINT data type is -2,147,483,648 to +2,147,483,647.	<p>Register 2 Register 1</p>  <p>(Two's Complement Value)</p>
BIT	Bit	A Bit data type is the smallest unit of memory. It has two states, 1 or 0. A BIT string may have length N.	
BYTE	Byte	A Byte data type has an 8-bit value. The valid range is 0 to 255 (0 to FF in hexadecimal).	
WORD	Word	A Word data type uses 16 consecutive bits of data memory; but, instead of the bits in the data location representing a number, the bits are independent of each other. Each bit represents its own binary state (1 or 0), and the bits are not looked at together to represent an integer number. The valid range of word values is 0 to FFFF.	<p>Register 1</p>  <p>(16 bit positions)</p>
DWORD	Double Word	A Double Word data type has the same characteristics as a single word data type, except that it uses 32 consecutive bits in data memory instead of 16 bits.	<p>Register 2 Register 1</p>  <p>(32 bit states)</p>
BCD-4	Four-Digit Binary Coded Decimal	Four-digit BCD numbers use 16-bit data memory locations. Each BCD digit uses four bits and can represent numbers between 0 and 9. This BCD coding of the 16 bits has a legal value range of 0 to 9999.	<p>Register 1</p>  <p>(4 BCD digits)</p>
REAL	Floating Point	Real numbers use 32 consecutive bits (actually two consecutive 16-bit memory locations). The range of numbers that can be stored in this format is from ± 1.401298E-45 to ± 3.402823E+38.	<p>Register 2 Register 1</p>  <p>(Two's Complement Value)</p>

S = Sign bit (0 = positive, 1 = negative).

System Status References

System status references in the Series 90 PLC are assigned to %S, %SA, %SB, and %SC memory. They each have a nickname. Examples of time tick references include T_10MS, T_100MS, T_SEC, and T_MIN. Examples of convenience references include FST_SCN, ALW_ON, and ALW_OFF.

Note

%S bits are read-only bits; do not write to these bits. You may, however, write to %SA, %SB, and %SC bits.

Listed below are available system status references, which may be used in an application program. When entering logic, either the reference or the nickname can be used. Refer to chapter 3, “Fault Explanations and Correction,” for more detailed fault descriptions and information on correcting the fault.

You cannot use these special names in another context.

Table 2-7. System Status References

Reference	Nickname	Definition
%S0001	FST_SCN	Set to 1 when the current sweep is the first sweep.
%S0002	LST_SCN	Reset from 1 to 0 when the current sweep is the last sweep.
%S0003	T_10MS	0.01 second timer contact.
%S0004	T_100MS	0.1 second timer contact.
%S0005	T_SEC	1.0 second timer contact.
%S0006	T_MIN	1.0 minute timer contact.
%S0007	ALW_ON	Always ON.
%S0008	ALW_OFF	Always OFF.
%S0009	SY_FULL	Set when the PLC fault table fills up. Cleared when an entry is removed from the PLC fault table and when the PLC fault table is cleared.
%S0010	IO_FULL	Set when the I/O fault table fills up. Cleared when an entry is removed from the I/O fault table and when the I/O fault table is cleared.
%S0011	OVR_PRE	Set when an override exists in %I, %Q, %M, or %G memory.
%S0013	PRG_CHK	Set when background program check is active.
%S0014	PLC_BAT	Set to indicate a bad battery in a Release 4 or later CPU. The contact reference is updated once per sweep.
%S0017	SNPXACT	SNP-X host is actively attached to the CPU.
%S0018	SNPX_RD	SNP-X host has read data from the CPU.
%S0019	SNPX_WT	SNP-X host has written data to the CPU.
%S0020		Set ON when a relational function using REAL data executes successfully. It is cleared when either input is NaN (Not a Number).
%S0021	FF_OVR	Used with reboot after Fatal Fault feature. Set ON when a fatal fault exists. Cleared when all fatal faults are cleared or the CPU mode is set to STOP/FAULT.
%S0022	USR_SW	Set to reflect the state of the CPU mode switch: 1=Run/On; 0 = Stop/Off
%S0032		Reserved for use by the programming software.

Table 2-7. System Status References - Continued

Reference	Name	Definition
%SA0001	PB_SUM	Set when a checksum calculated on the application program does not match the reference checksum. If the fault was due to a temporary failure, the discrete bit can be cleared by again storing the program to the CPU. If the fault was due to a hard RAM failure, the CPU must be replaced.
%SA0002	OV_SWP	Set when the PLC detects that the previous sweep took longer than the time specified by the user. Cleared when the PLC detects that the previous sweep did not take longer than the specified time. It is also cleared during the transition from STOP to RUN mode. Only valid if the PLC is in CONSTANT SWEEP mode.
%SA0003	APL_FLT	Set when an application fault occurs. Cleared when the PLC transitions from STOP to RUN mode.
%SA0009	CFG_MM	Set when a configuration mismatch is detected during system power-up or during a store of the configuration. Cleared by powering up the PLC when no mismatches are present or during a store of configuration that matches hardware.
%SA0010	HRD_CPU	Set when the diagnostics detects a problem with the CPU hardware. Cleared by replacing the CPU module.
%SA0011	LOW_BAT	Set when a low battery fault occurs. Cleared by replacing the battery and ensuring that the PLC powers up without the low battery condition.
%SA0014	LOS_IOM	Set when an I/O module stops communicating with the PLC CPU. Cleared by replacing the module and cycling power on the main rack.
%SA0015	LOS_SIO	Set when an option module stops communicating with the PLC CPU. Cleared by replacing the module and cycling power on the main rack.
%SA0019	ADD_IOM	Set when an I/O module is added to a rack. Cleared by cycling power on the main rack and when the configuration matches the hardware after a store.
%SA0020	ADD_SIO	Set when an option module is added to a rack. Cleared by cycling power on the main rack and when the configuration matches the hardware after a store.
%SA0027	HRD_SIO	Set when a hardware failure is detected in an option module. Cleared by replacing the module and cycling power on the main rack.
%SA0031	SFT_SIO	Set when an unrecoverable software fault is detected in an option module. Cleared by cycling power on the main rack and when the configuration matches the hardware.
%SB0010	BAD_RAM	Set when the CPU detects corrupted RAM memory at power-up. Cleared when the CPU detects that RAM memory is valid at power-up.
%SB0011	BAD_PWD	Set when a password access violation occurs. Cleared when the PLC fault table is cleared.
%SB0013	SFT_CPU	Set when the CPU detects an unrecoverable error in the software. Cleared by clearing the PLC fault table.
%SB0014	STOR_ER	Set when an error occurs during a programmer store operation. Cleared when a store operation is completed successfully.

Table 2-7. System Status References - Continued

Reference	Nickname	Definition
%SC0009	ANY_FLT	Set when any fault occurs. Cleared when both fault tables have no entries.
%SC0010	SY_FLT	Set when any fault occurs that causes an entry to be placed in the PLC fault table. Cleared when the PLC fault table has no entries.
%SC0011	IO_FLT	Set when any fault occurs that causes an entry to be placed in the I/O fault table. Cleared when the I/O fault table has no entries.
%SC0012	SY_PRES	Set as long as there is at least one entry in the PLC fault table. Cleared when the PLC fault table has no entries.
%SC0013	IO_PRES	Set as long as there is at least one entry in the I/O fault table. Cleared when the I/O fault table has no entries.
%SC0014	HRD_FLT	Set when a hardware fault occurs. Cleared when both fault tables have no entries.
%SC0015	SFT_FLT	Set when a software fault occurs. Cleared when both fault tables have no entries.

Note: Any %S reference not listed here is reserved and not to be used in program logic.

Function Block Structure

Each rung of logic is composed of one or more programming instructions. These may be simple relays or more complex functions.

Format of Ladder Logic Relays

The programming software includes several types of relay functions. These functions provide basic flow and control of logic in the program. Examples include a normally open relay contact and a negated coil. Each of these relay contacts and coils has one input and one output. Together, they provide logic flow through the contact or coil.

Each relay contact or coil must be given a reference that is entered when selecting the relay. For a contact, the reference represents a location in memory that determines the flow of power into the contact. In the following example, if reference %I0122 is ON, power will flow through this relay contact.

```
%I0122
-| |-
```

For a coil, the reference represents a location in memory that is controlled by the flow of power into the coil. In this example, if power flows into the left side of the coil, reference %Q0004 is turned ON.

%Q0004
-()-

The programming software and the Hand-Held Programmer both have a coil check function that checks for multiple uses of %Q or %M references with relay coils or outputs on functions.

Format of Program Function Blocks

Some functions are very simple, like the MCR function, which is shown with the abbreviated name of the function within brackets:

-[MCR]-

Other functions are more complex. They may have several places where you will enter information to be used by the function.

The generic function block illustrated below is multiplication (MUL); parameters vary with the type of function block. Its parts are typical of many program functions. The upper part of the function block shows the name of the function.

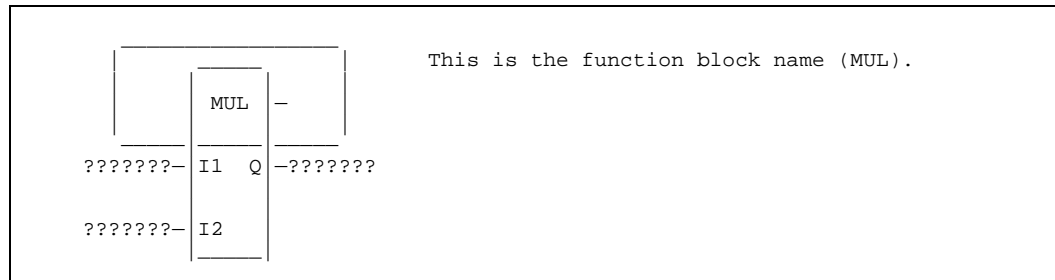

Function Block Parameters

Each line entering the left side of a function block represents an input for that function. There are two forms of input that can be passed into a function block: constants and references. A constant is an explicit value. A reference is the address of a value.

In the following example, input parameter I1 comes into the ADD function block as a constant, and input parameter I2 comes in as a reference.

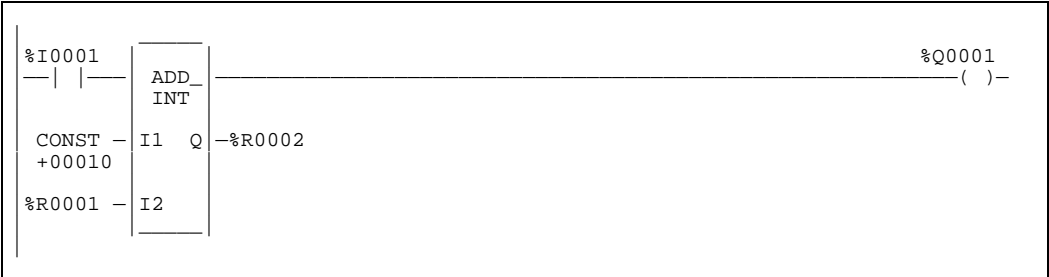

Each line exiting the right side of the function block represents an output. There is only one form of output from a function block or reference. Outputs can never be written to constants.

Where the question marks appear on the left of a function block, you will enter either the data itself, a reference location where the data is found, or a variable representing the reference location where the data is found. Where question marks appear on the right of a function block, you will usually enter a reference location for data to be output by the function block or a variable that represents the reference location for data to be output by the function block.

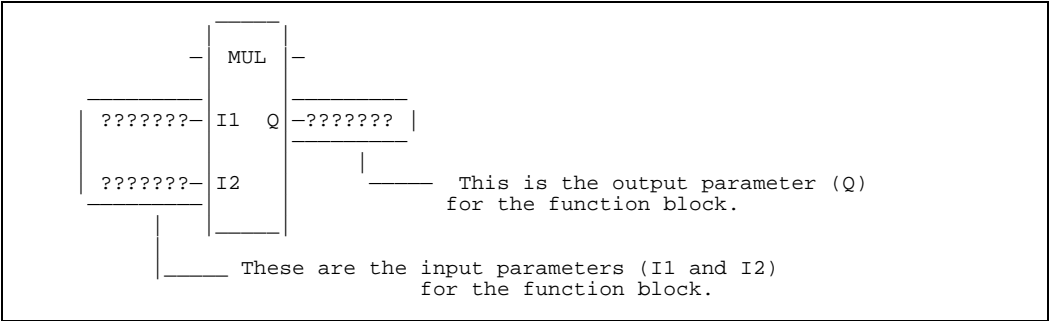

Most function blocks do not change input data; instead, they place the result of the operation in an output reference.

For functions that operate on tables, a length can be selected for the function. In the following function block, the LEN operand specifies the number of words to be moved.

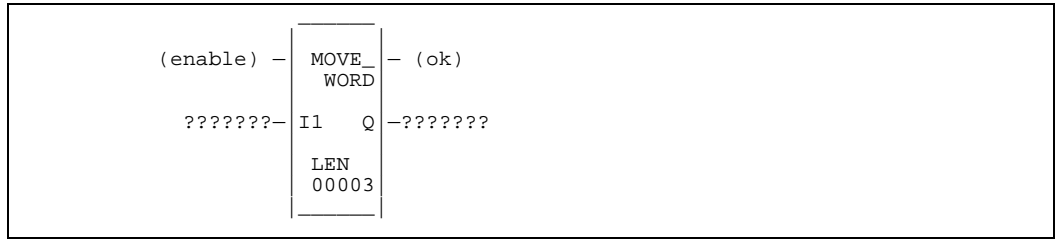

Timer, counter, BITSEQ, and ID functions require an address for the location of three words (registers) which store the current value, preset value, and a control word or “Instance” of the function.



Power Flow In and Out of a Function

Power flows into a function block on the upper left. Often, enabling logic is used to control power flow to a function block; otherwise, the function block executes unconditionally each CPU sweep.

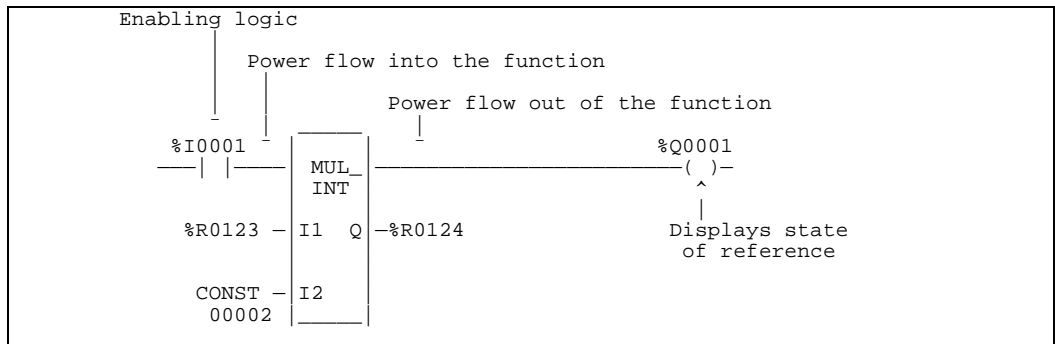

Note

Function blocks cannot be tied directly to the left power rail. You can use %S7, the ALW_ON (always on) bit with a normally open contact tied to the power rail to call a function every sweep.

Power flows out of the function block on the upper right. It may be passed to other program logic or to a coil (optional). Function blocks pass power when they execute successfully.

Section 3: *Power-Up and Power-Down Sequences*

There are two possible power-up sequences in the Series 90-30 PLC; a cold power-up and a warm power-up. The CPU normally uses the cold power-up sequence. However, in a Model 331 or higher PLC system, if the time that elapses between a power-down and the next power-up is less than five seconds, the warm power-up sequence is used.

Power-Up

A cold power-up consists of the following sequence of events. A warm power-up sequence skips Step 1.

1. The CPU will run diagnostics on itself. This includes checking a portion of battery-backed RAM to determine whether or not the RAM contains valid data.
2. If an EPROM, EEPROM, or flash is present and the PROM power-up option in the PROM specifies that the PROM contents should be used, the contents of PROM are copied into RAM memory. If an EPROM, EEPROM, or flash is not present, RAM memory remains the same and is not overwritten with the contents of PROM.
3. The CPU interrogates each slot in the system to determine which boards are present.
4. The hardware configuration is compared with software configuration to ensure that they are the same. Any mismatches detected are considered faults and are alarmed. Also, if a board is specified in the software configuration but a different module is present in the actual hardware configuration, this condition is a fault and is alarmed.
5. If there is no software configuration, the CPU will use the default configuration.
6. The CPU establishes the communications channel between itself and any intelligent modules.
7. In the final step of the execution, the mode of the first sweep is determined based on CPU configuration. If **RUN** mode, the sweep proceeds as described under “**STOP-to-RUN** Mode Transition.” Figure 2-5 on the next page shows the decision sequence for the CPU when it decides whether to copy from PROM or to power-up in **STOP** or **RUN** mode.

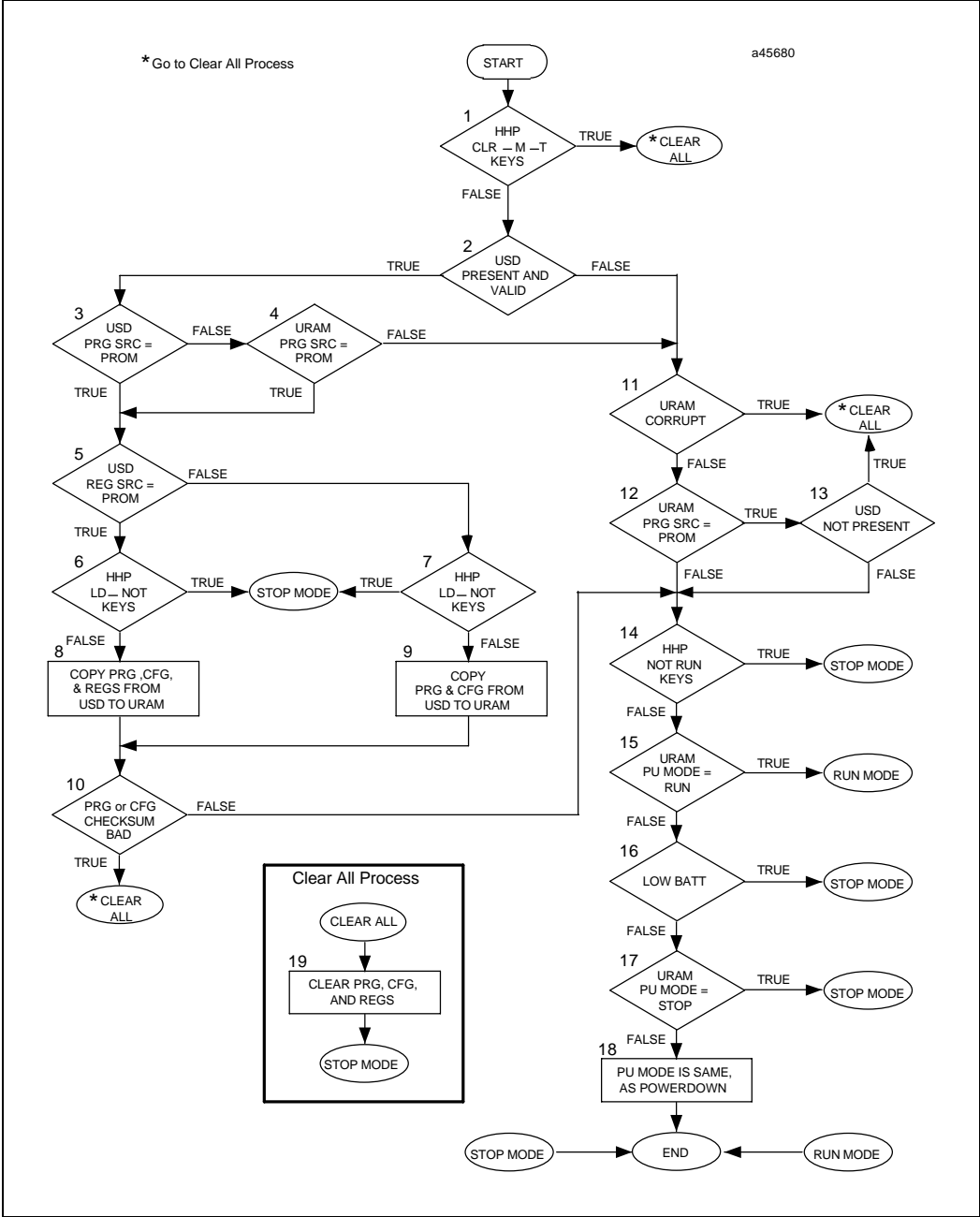

Figure 2-5. Power-Up Sequence

Prior to the START statement on the Power Up Flowchart, the CPU goes through power up diagnostics which test various peripheral devices used by the CPU and tests RAM. After completing diagnostics, internal data structures and peripheral devices used by the CPU get initialized. The CPU then determines if User Ram has been corrupted. If User Ram is corrupted the user program and configuration are cleared out and defaulted and all user registers are cleared.

FLOW CHART TERMS:

PRG = user program

CFG = user configuration

REGS = user registers (%I, %Q, %M, %G, %R, %AI, and %AQ references).

USD = user storage device, either an EEPROM or flash device.

URAM = non-volatile user ram which contains PRG, CFG, and REGS.

FLOW CHART EXPANDED TEXT:

- (1) Are the <CLR> and <M_T> keys being pressed on the HHP during power-up to clear all URAM?
- (2) Is the USD present (could only be missing on models that use EEPROM device) and is the information on the USD valid?
- (3) Is the PRG SRC parameter in the USD set to Prom meaning to load the PRG and CFG from the USD device?
- (4) Is the PRG SRC parameter in the URAM set to Prom meaning to load the PRG and CFG from the USD device?
- (5) Is the REG SRC parameter in the USD set to Prom meaning to load the REGS from the USD device?
- (6 & 7) Are the <LD> and <NOT> keys being pressed on the HHP during power-up to keep the PRG, CFG, and REGS from being loaded from USD?
- (8) Copy PRG, CFG, and REGS from the USD to URAM.
- (9) COPY PRG, and CFG from the USD to URAM.
- (10) Is the PRG or CFG checksums just loaded from USD invalid?
- (11) Is the URAM corrupted? Could be due to being powered down with out a battery attached or a low battery. Could also be due to updating firmware.
- (12) Is the PRG SRC parameter in the URAM set to Prom meaning to load the PRG and CFG from the USD device?
- (13) Is the USD present? Only applicable to models that use EEPROM device.
- (14) Are the <NOT> and <RUN> keys being pressed on the HHP during power-up to unconditionally power-up in Stop Mode?
- (15) Is the PWR UP parameter in URAM set to **RUN**?
- (16) Is the battery low?
- (17) Is the PWR UP parameter in URAM set to **STOP**?
- (18) Set the power up mode to what ever the power down mode was.
- (19) Clear PRG, CFG, and REGS.

Power-Down

System power-down occurs when the power supply detects that incoming AC power has dropped for more than one power cycle or the output of the 5-volt power supply has fallen to less than 4.9 volts DC.

Section 4: *Clocks and Timers*

Clocks and timers provided by the Series 90-30 PLC include an elapsed time clock, a time-of-day clock, a watchdog timer, and a constant sweep timer. Three types of timer function blocks include an on-delay timer, an off-delay timer, and a retentive on-delay timer (also called a watch clock timer). Four time-tick contacts cycle on and off for 0.01 second, 0.1 second, 1.0 second, and 1 minute intervals.

Elapsed Time Clock

The elapsed time clock uses 100 microsecond “ticks” to track the time elapsed since the CPU powered on. The clock is not retentive across a power failure; it restarts on each power-up. Once per second the hardware interrupts the CPU to enable a seconds count to be recorded. This seconds count rolls over approximately 100 years after the clock begins timing.

Because the elapsed time clock provides the base for system software operations and timer function blocks, it can not be reset from the user program or the programmer. However, the application program can read the current value of the elapsed time clock by using Service Request 16.

Time-of-Day Clock

The time of day in Series 90-30 PLC Model 331 and higher is maintained by a hardware time-of-day clock. The time-of-day clock maintains seven time functions:

- Year (two digits)
- Month
- Day of month
- Hour
- Minute
- Second
- Day of week

The time-of-day clock is battery-backed and maintains its present state across a power failure. However, unless you initialize the clock, the values it contains are meaningless. The application program can read and set the time-of-day clock using Service Request #7. The time-of-day clock can also be read and set from the CPU configuration software. Note that the Hand Held Programmer does not allow you to change the Time of Day clock while key switch protection is active.

The time-of-day clock is designed to handle month-to-month and year-to-year transitions. It automatically compensates for leap years until the year 2079.

Watchdog Timer

A watchdog timer in the Series 90-30 PLC is designed to catch catastrophic failure conditions that result in an unusually long sweep. The timer value for the watchdog timer is 500 milliseconds in the 35x and 36x series of PLC CPUs; this is a fixed value which cannot be changed. The watchdog timer always starts from zero at the beginning of each sweep.

For 331 and lower model 90-30 CPUs, if the watchdog timeout value is exceeded, the OK LED goes off; the CPU is placed in reset and completely shuts down; and outputs go to their default state. No communication of any form is possible, and all microprocessors on all boards are halted. To recover, power must be cycled on the rack containing the CPU. In the 340 and higher 90-30 CPUs, a watchdog timeout causes the CPU to reset, execute its powerup logic, generate a watchdog failure fault, and change its mode to **STOP**.

Constant Sweep Timer

The constant sweep timer controls the length of a program sweep when the Series 90-30 PLC operates in **CONSTANT SWEEP TIME** mode. In this mode of operation, each sweep consumes the same amount of time. Typically, for most application programs, the input scan, application program logic scan, and output scan do not require exactly the same amount of execution time in each sweep. The value of the constant sweep timer is set by the programmer and can be any value from 5 to the value of the watchdog timer (default is 100 milliseconds).

If the constant sweep timer expires before the completion of the sweep and the previous sweep was not oversweep, the PLC places an oversweep alarm in the PLC fault table. At the beginning of the next sweep, the PLC sets the OV_SWP fault contact. The OV_SWP contact is reset when the PLC is not in **CONSTANT SWEEP TIME** mode or the time of the last sweep did not exceed the constant sweep timer.

Time-Tick Contacts

The Series 90 PLC provides four time-tick contacts with time durations of 0.01 second, 0.1 second, 1.0 second, and 1 minute. The state of these contacts does not change during the execution of the sweep. These contacts provide a pulse having an equal on and off time duration. The contacts are referenced as T_10MS (0.01 second), T_100MS (0.1 second), T_SEC (1.0 second), and T_MIN (1 minute).

The following timing diagram represents the on/off time duration of these contacts.

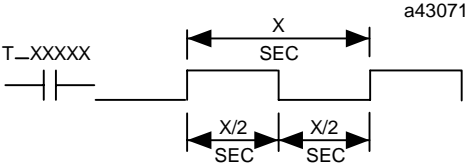

Figure 2-6. Time-Tick Contact Timing Diagram

Section 5: System Security

Security in Series 90-30 PLCs is designed to prevent unauthorized changes to the contents of a PLC. There are four security levels available in the PLC. The first level, which is always available, provides only the ability to read PLC data; no changes are permitted to the application. The other three levels have access to each level protected by a password.

Each higher privilege level permits greater change capabilities than the lower level(s). Privilege levels accumulate in that the privileges granted at one level are a combination of that level, plus all lower levels. The levels and their privileges are:

Privilege Level	Description
Level 1	Any data, except passwords may be read. This includes all data memories (%I, %Q, %AQ, %R, etc.), fault tables, and all program block types (data, value, and constant). No values may be changed in the PLC.
Level 2	This level allows write access to the data memories (%I, %R, etc.).
Level 3	This level allows write access to the application program in STOP mode only.
Level 4	This is the default level for systems which have no passwords set. The default level for a system with passwords is to the highest unprotected level. This level, the highest, allows read and write access to all memories as well as passwords in both RUN and STOP mode. (Configuration data cannot be changed in RUN mode.)

Passwords

There is one password for each privilege level in the PLC. (No password can be set for level 1 access.) Each password may be unique; however, the same password can be used for more than one level. Passwords are one to four ASCII characters in length; they can only be entered or changed with the programming software or the Hand-Held Programmer.

A privilege level change is in effect only as long as communications between the PLC and the programmer are intact. There does not need to be any activity, but the communications link must not be broken. If there is no communication for 15 minutes, the privilege level returns to the highest unprotected level.

Upon connection of the PLC, the programming software requests the protection status of each privilege level from the PLC. The programming software then requests the PLC to move to the highest unprotected level, thereby giving the programming software access to the highest unprotected level without having to request any particular level. When the Hand-Held Programmer is connected to the PLC, the PLC reverts to the highest unprotected level.

Privilege Level Change Requests

The privilege level can be set in Control software (not in VersaPro). A programmer requests a privilege level change by supplying the new privilege level and the password for that level. A

privilege level change is denied if the password sent by the programmer does not agree with the password stored in the PLC's password access table for the requested level. The current privilege level is maintained and no change will occur. If you attempt to access or modify information in the PLC using the Hand-Held Programmer without the proper privilege level, the Hand-Held Programmer will respond with an error message that the access is denied.

Locking/Unlocking Subroutines

Subroutine blocks can be locked and unlocked using the block locking feature of programming software. Two types of locks are available:

Type of Lock	Description
View	Once locked, you cannot zoom into that subroutine.
Edit	Once locked, the information in the subroutine cannot be edited.

A previously view locked or edit locked subroutine may be unlocked in the block declaration editor unless it is permanently view locked or permanently edit locked.

A search or search and replace function may be performed on a view locked subroutine. If the target of the search is found in a view locked subroutine, one of the following messages is displayed, instead of logic:

```
Found in locked block <block_name> (Continue/Quit)
```

or

```
Cannot write to locked block <block_name> (Continue/Quit)
```

You may continue or abort the search.

Folders that contain locked subroutines may be cleared or deleted. If a folder contains locked subroutines, these blocks remain locked when the programming software Copy, Backup, and Restore folder functions are used.

Permanently Locking a Subroutine

In addition to VIEW LOCK and EDIT LOCK, there are two types of permanent locks. If a PERMANENT VIEW LOCK is set, all zooms into a subroutine are denied. If a PERMANENT EDIT LOCK is set, all attempts to edit the block are denied.

Caution

The permanent locks differ from the regular VIEW LOCK and EDIT LOCK in that once set, they cannot be removed.

Once a PERMANENT EDIT LOCK is set, it can only be changed to a PERMANENT VIEW LOCK. A PERMANENT VIEW LOCK cannot be changed to any other type of lock.

Section 6: Series 90-30 I/O System

The PLC I/O system provides the interface between the Series 90-30 PLC and user-supplied devices and equipment. The PLC system I/O is called Series 90-30 I/O. Series 90-30 I/O modules plug directly into slots in the CPU baseplate or into slots in any of the expansion baseplates for the Series 90-30 PLC Model 331 or higher. Model 331, 340, and 341 I/O systems support up to 49 Series 90-30 I/O modules (5 racks). Model 350 to 364 I/O systems support up to 79 Series 90-30 I/O modules (8 racks). The Series 90-30 PLC Model 311 or Model 313 5-slot baseplate supports up to 5 Series 90-30 I/O modules; the Model 323 10-slot baseplate supports up to 10 Series 90-30 I/O modules.

The I/O structure for the Series 90-30 PLC is shown in the following figure.

PLC I/O System

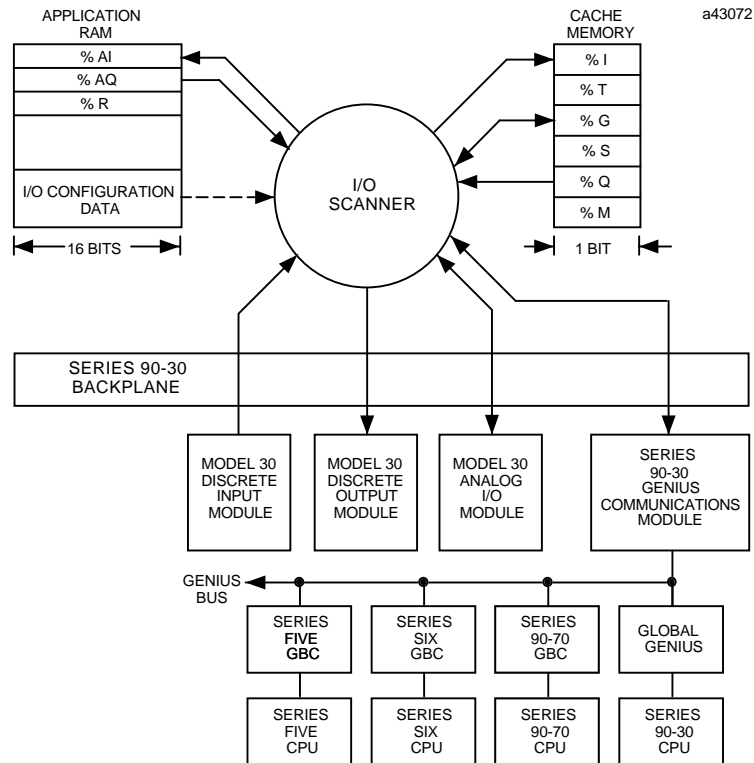

Figure 2-7. Series 90-30 I/O Structure

Note

The drawing shown above is specific to the 90-30 I/O structure. Intelligent and option modules are not part of the I/O scan; they use the System Communication Window.

Series 90-30 I/O Modules

Series 90-30 I/O modules are available as five types, discrete input, discrete output, analog input, analog output, and option modules. The following table lists the Series 90-30 I/O modules by catalog number, number of I/O points, and a brief description of each module.

Note

All of the I/O modules listed below may not be available at the time this manual is printed. For current availability, consult your local GE Fanuc PLC distributor or GE Fanuc sales representative. Refer to the *Series 90-30 I/O Module Specifications Manual*, GFK-0898, for the specifications and wiring information of each Series 90-30 I/O module.

Figure 2-8. Series 90-30 I/O Modules

Catalog Number	Points	Description	Pub Number
<i>Discrete Modules - Input</i>			
IC693MDL230	8	120 VAC Isolated	GFK-0898
IC693MDL231	8	240 VAC Isolated	GFK-0898
IC693MDL240	16	120 VAC	GFK-0898
IC693MDL241	16	24 VAC/DC Positive/Negative Logic	GFK-0898
IC693MDL630	8	24 VDC Positive Logic	GFK-0898
IC693MDL632	8	125 VDC Positive/Negative Logic	GFK-0898
IC693MDL633	8	24 VDC Negative Logic	GFK-0898
IC693MDL634	8	24 VDC Positive/Negative Logic	GFK-0898
IC693MDL640	16	24 VDC Positive Logic	GFK-0898
IC693MDL641	16	24 VDC Negative Logic	GFK-0898
IC693MDL643	16	24 VDC Positive Logic, FAST	GFK-0898
IC693MDL644	16	24 VDC Negative Logic, FAST	GFK-0898
IC693MDL645	16	24 VDC Positive/Negative Logic	GFK-0898
IC693MDL646	16	24 VDC Positive/Negative Logic, FAST	GFK-0898
IC693MDL652	32	24 VDC Position/Negative Logic	GFK-0898
IC693MDL653	32	24 VDC Positive/Negative Logic, FAST	GFK-0898
IC693MDL654	32	5/12 VDC (TTL) Positive/Negative Logic	GFK-0898
IC693MDL655	32	24 VDC Positive/Negative Logic	GFK-0898
IC693ACC300	8/16	Input Simulator	GFK-0898

Table 2-8. Series 90-30 I/O Modules - Continued

Catalog Number	Points	Description	Pub Number
<i>Discrete Modules - Output</i>			
IC693MDL310	12	120 VAC, 0.5A	GFK-0898
IC693MDL330	8	120/240 VAC, 2A	GFK-0898
IC693MDL340	16	120 VAC, 0.5A	GFK-0898
IC693MDL390	5	120/240 VAC Isolated, 2A	GFK-0898
IC693MDL730	8	12/24 VDC Positive Logic, 2A	GFK-0898
IC693MDL731	8	12/24 VDC Negative Logic, 2A	GFK-0898
IC693MDL732	8	12/24 VDC Positive Logic, 0.5A	GFK-0898
IC693MDL733	8	12/24 VDC Negative Logic, 0.5A	GFK-0898
IC693MDL734	6	125 VDC Positive/Negative Logic, 2A	GFK-0898
IC693MDL740	16	12/24 VDC Positive Logic, 0.5A	GFK-0898
IC693MDL741	16	12/24 VDC Negative Logic, 0.5A	GFK-0898
IC693MDL742	16	12/24 VDC Positive Logic, 1A	GFK-0898
IC693MDL750	32	12/24 VDC Negative Logic	GFK-0898
IC693MDL751	32	12/24 VDC Positive Logic, 0.3A	GFK-0898
IC693MDL752	32	5/24 VDC (TTL) Negative Logic, 0.5A	GFK-0898
IC693MDL753	32	12/24 VDC Positive/Negative Logic, 0.5A	GFK-0898
IC693MDL930	8	Relay, N.O., 4A Isolated	GFK-0898
IC693MDL931	8	Relay, BC, Isolated	GFK-0898
IC693MDL940	16	Relay, N.O., 2A	GFK-0898
IC693DVM300	4 ch	Digital Valve Driver	GFK-0898
<i>Input/Output Modules</i>			
IC693MDR390	8/8	24 VDC Input, Relay Output	GFK-0898
IC693MAR590	8/8	120 VAC Input, Relay Output	GFK-0898
<i>Analog Modules</i>			
IC693ALG220	4 ch	Analog Input, Voltage	GFK-0898
IC693ALG221	4 ch	Analog Input, Current	GFK-0898
IC693ALG222	16	Analog Input, Voltage	GFK-0898
IC693ALG223	16	Analog Input, Current	GFK-0898
IC693ALG390	2 ch	Analog Output, Voltage	GFK-0898
IC693ALG391	2 ch	Analog Output, Current	GFK-0898
IC693ALG392	8 ch	Analog Output, Current/Voltage	GFK-0898
IC693ALG442	4/2	Analog, Current/Voltage Combination Input/Output	GFK-0898

Table 2-8. Series 90-30 I/O Modules - Continued

Catalog Number	Description	Pub Number
	<i>Option Modules</i>	
IC693APU300	High Speed Counter	GFK-0293
IC693APU301	Motion Mate APM Module, 1-Axis-Follower Mode	GFK-0781
IC693APU301	Motion Mate APM Module, 1-Axis-Standard Mode	GFK-0840
IC693APU302	Motion Mate APM Module, 2-Axis-Follower Mode	GFK-0781
IC693APU302	Motion Mate APM Module, 2-Axis-Standard Mode	GFK-0840
IC693DSM302	Motion Mate Digital Servo Module (DSM302)	GFK-1464
IC693DSM314	Motion Mate Digital Servo Module (DSM314)	GFK-1742
IC693TCM302/303	Temperature Control Modules	GFK-1466
IC693PTM100/101	Power Transducer Module	GFK-1734
IC693APU305	I/O Processor Module	GFK-0521
IC693CMM321	Ethernet Communications Module	GFK-1084
IC693ADC311	Alphanumeric Display Coprocessor	GFK-0521
IC693BEM331	Genius Bus Controller	GFK-1034
IC693BEM320	I/O Link Interface Module (slave)	GFK-0631
IC693BEM321	I/O Link Interface Module (master)	GFK-0823
IC693BEM330	FIP Remote I/O Scanner	GFK-1038
IC693BEM340	FIP Bus Controller	GFK-1037
IC693CMM302	Enhanced Genius Communications Module	GFK-0695
IC693PCM300	PCM, 160K Bytes (35KBytes User MegaBasic Program)	GFK-0255
IC693PCM301	PCM, 192K Bytes (47KBytes User MegaBasic Program)	GFK-0255
IC693PCM311	PCM, 640K Bytes (190KBytes User MegaBasic Program)	GFK-0255

I/O Data Formats

Discrete inputs and discrete outputs are stored as bits in bit cache (status table) memory. Analog input and analog output data are stored as words and are memory resident in a portion of application RAM memory allocated for that purpose.

Default Conditions for Series 90-30 Output Modules

At power-up, Series 90-30 discrete output modules default to outputs off. They will retain this default condition until the first output scan from the PLC. Analog output modules can be configured with a jumper located on the module's removable terminal block to either default to zero or retain their last state. Also, analog output modules may be powered from an external power source so that, even though the PLC has no power, the analog output module will continue to operate in its selected default state.

Diagnostic Data

Diagnostic bits are available in %S memory that will indicate the loss of an I/O module or a mismatch in I/O configuration. Diagnostic information is not available for individual I/O points. More information on fault handling can be in Chapter 3, “Fault Explanations and Correction.”

Global Data

Genius Global Data

The Series 90-30 PLC supports very fast sharing of data between multiple CPUs using Genius global data. The Genius Bus Controller, IC693BEM331 in CPU firmware release 5 and later, and the Enhanced Genius Communications Module, IC693CMM302, can broadcast up to 128 bytes of data to other PLCs or computers. They can receive up to 128 bytes from each of the up to 30 other Genius controllers on the network. Data can be broadcast from or received into any memory type, not just %G global bits.

The original Genius Communications Module, IC693CMM301, is limited to fixed %G addresses and can only exchange 32 bits per serial bus address from SBA 16 to 23. This module should not be used as the Enhanced Genius Communications Module has over 100 times the capability.

Global data can be shared between Series Five, Series Six, and Series 90 PLCs connected to the same Genius I/O bus.

Ethernet Global Data

Similar to Genius Global Data, Ethernet Global Data (EGD) allows one device (the producer) to transfer data to one or more other devices (the consumers) on the network. For details on configuring EGD using the Windows-based programmers, refer to the programmer Online Help and to the *TCP/IP Ethernet Communications for the Series 90 PLC User's Manual*, GFK-1541.

The Model 364 CPU (release 9.0 and later) supports connection to an Ethernet network through either (but not both) of two built-in Ethernet ports. AAUI and 10BaseT ports are provided. The Model 364 (release 9.10 or later) is the only Series 90-30 CPU that supports EGD.

Local Logic Programs

Local Logic programs can be created for the DSM314 motion control module using the VersaPro Local Logic Editor. This feature requires VersaPro 1.1 or later software and is supported by CPUs 350, 352, 360, 363 and 364 with firmware release 10.0 or later. These programs are stored to the CPU from the programmer. In turn, the CPU automatically stores them to the DSM314 along with the module's configuration settings. The limit on the size of all Local Logic programs is 65280 bytes.

A Local Logic program runs synchronously with the motion program, but is independent of the PLC's CPU scan. This allows the DSM314 to interact quickly with motion I/O signals on its faceplate connectors. This internal response to motion I/O signals is much faster than would be

possible if the logic for these signals was handled in the main ladder program running in the PLC. This would be due to (1) the delay in communicating the signals across the backplane and (2) the longer PLC sweep time.

For detailed information on Local Logic Programs and the DSM314, see GFK-1742, the *Motion Mate DSM314 for Series 90-30 PLCs User's Manual*. For information on configuration and writing Local Logic Programs, refer to the VersPro online Help feature for the DSM314.

Chapter 3

Fault Explanation and Correction

This chapter is an aid to troubleshooting the Series 90-30 PLC system. It explains the fault descriptions, which appear in the PLC fault table, and the fault categories, which appear in the I/O fault table.

Each fault explanation in this chapter lists the fault description for the PLC fault table or the fault category for the I/O fault table. Find the fault description or fault category corresponding to the entry on the applicable fault table displayed on your programmer screen. Beneath it is a description of the cause of the fault along with instructions to correct the fault.

Chapter 3 contains the following sections:

Section	Title	Description	Page
1	Fault Handling	Describes the type of faults that may occur in the Series 90-30 and how they are displayed in the fault tables. Descriptions of the PLC and I/O fault table displays are also included.	3-2
2	PLC Fault Table Explanations	Provides a fault description of each PLC fault and instructions to correct the fault.	3-8
3	I/O Fault Table Explanations	Describes the Loss of I/O Module and Addition of I/O Module fault categories.	3-17

Section 1: Fault Handling

Faults occur in the Series 90-30 PLC system when certain failures or conditions happen which affect the operation and performance of the system. These conditions, such as the loss of an I/O module or rack, may affect the ability of the PLC to control a machine or process. These conditions may also have beneficial effects, such as when a new module comes online and is now available for use. Or, these conditions may only act as an alert, such as a low battery signal which indicates that the battery protecting the memory needs to be changed.

Alarm Processor

The condition or failure itself is called a fault. When a fault is received and processed by the CPU, it is called an alarm. The software in the CPU which handles these conditions is called the Alarm Processor. The interface to the user for the Alarm Processor is through the programming software. Any detected fault is recorded in a fault table and displayed on either the PLC fault table screen or the I/O fault table screen, as applicable.

Classes of Faults

The Series 90-30 PLCs detect several classes of faults. These include internal failures, external failures, and operational failures.

Fault Class	Examples
Internal Failures	Non-responding modules. Low battery condition. Memory checksum errors.
External I/O Failures	Loss of rack or module. Addition of rack or module.
Operational Failures	Communication failures. Configuration failures. Password access failures.

System Reaction to Faults

Hardware failures require that either the system be shut down or the failure is tolerated. I/O failures may be tolerated by the PLC system, but they may be intolerable by the application or the process being controlled. Operational failures are normally tolerated. Series 90-30 faults have two attributes:

Attribute	Description
Fault Table Affected	I/O Fault Table PLC Fault Table
Fault Action	Fatal Diagnostic Informational

Fault Tables

Two fault tables are maintained in the PLC for logging faults, the I/O fault table for logging faults related to the I/O system and the PLC fault table for logging all other faults. The following table lists the fault groups, their fault actions, the fault tables affected, and the “name” for system discrete %S points that are affected.

Table 3-1. Fault Summary

Fault Group	Fault Action	Fault Table	Special Discrete Fault References			
			io_ft	any_ft	io_pres	los_iom
Loss of or Missing I/O Module	Diagnostic	I/O	io_ft	any_ft	io_pres	los_iom
Loss of or Missing Option Module	Diagnostic	PLC	sy_ft	any_ft	sy_pres	los_sio
System Configuration Mismatch	Fatal	PLC	sy_ft	any_ft	sy_pres	cfg_mm
PLC CPU Hardware Failure	Fatal	PLC	sy_ft	any_ft	sy_pres	hrd_cpu
Program Checksum Failure	Fatal	PLC	sy_ft	any_ft	sy_pres	pb_sum
Low Battery	Diagnostic	PLC	sy_ft	any_ft	sy_pres	low_bat
PLC Fault Table Full	Diagnostic	—	sy_full			
I/O Fault Table Full	Diagnostic	—	io_full			
Application Fault	Diagnostic	PLC	sy_ft	any_ft	sy_pres	apl_ft
No User Program	Informational	PLC	sy_ft	any_ft	sy_pres	no_prog
Corrupted User RAM	Fatal	PLC	sy_ft	any_ft	sy_pres	bad_ram
Password Access Failure	Diagnostic	PLC	sy_ft	any_ft	sy_pres	bad_pwd
PLC Software Failure	Fatal	PLC	sy_ft	any_ft	sy_pres	sft_cpu
PLC Store Failure	Fatal	PLC	sy_ft	any_ft	sy_pres	stor_er
Constant Sweep Time Exceeded	Diagnostic	PLC	sy_ft	any_ft	sy_pres	ov_swp
Unknown PLC Fault	Fatal	PLC	sy_ft	any_ft	sy_pres	
Unknown I/O Fault	Fatal	I/O	io_ft	any_ft	io_pres	

Fault Action

Faults can be fatal, diagnostic or informational.

Fatal faults cause the fault to be recorded in the appropriate table, any diagnostic variables to be set, and the system to be halted. Diagnostic faults are recorded in the appropriate table, and any diagnostic variables are set. Informational faults are only recorded in the appropriate table.

Possible fault actions are listed in the following table.

Table 3-2. Fault Actions

Fault Action	Response by CPU
Fatal	Log fault in fault table. Set fault references. Go to STOP mode.
Diagnostic	Log fault in fault table. Set fault references.
Informational	Log fault in fault table.

When a fault is detected, the CPU uses the fault action for that fault. Fault actions are not configurable in the Series 90-30 PLC, except for the following condition.

Reboot After Fatal Fault

This feature is applicable for CPU models 350, 352, 360, 363 and 364. PLC CPU Firmware release 10.0, or later and VersaPro 1.10 PLC software are required to use this feature. Reboot After Fatal Fault, if enabled, allows the Series 90-30 PLC system to automatically resume normal operation after a fatal fault has occurred. This feature is useful in applications where the PLC experiences a nuisance fault, such as due to noise from an electrical storm, and no support person is on-site to restart the PLC. However, there may be applications where it is not safe to use this feature, as noted in the warning below.

Warning

The Reboot After Fatal Fault feature should not be used (should be set to Disabled) in applications where a restart under fault conditions could produce an unsafe condition in the controlled equipment. It is the responsibility of the system designers to determine whether this feature can be used safely with their equipment. Failure to follow this warning could result in injury or death to personnel and/or damage to equipment.

Following the fatal fault, the PLC will automatically reset and resume execution. If fatal faults are present following the power up, the PLC will still be allowed to transition to Run mode. This feature is enabled by the Ignore Fatal Faults (or Fatal Fault Override) parameter in the CPU's hardware configuration. The maximum number of retries and the time period in which these retries can occur is set through Service Request #48: Auto Reset. Three parameters must be

configured to enable automatic reset; *Unlimited Retries*, *Number of Retries Allowed* and *Retry Period (in minutes)*.

Service Request #49: Auto Reset Statistics, can then be used to determine the number of fatal faults and retries that have occurred. There are three parameters associated with this Service Request: *Command* (set to 0 = Return total number of Fatal Faults and Number of Retries that have occurred; set to 1 = Initialize the Total Number of Fatal Faults and Total Number of Retries to 0), *Returned Value* = Total Number of Fatal Faults that have occurred, and Returned Value = *Total Number of Auto Reset Retries*.

The configuration for this feature can be set to require the operator to cycle power rather than providing for automatic recovery. In this mode, fatal faults will be ignored at power up. A system status bit, %S21 indicates to the user’s application program that a fatal fault exists. This status bit is set to 1 whenever retry is successful and remains set until all faults are cleared or the mode is set to STOP/FAULT.

For information on configuration of this feature, refer to the VersaPro online Help.

Fault References

Fault references in the Series 90-30 are of one type, fault summary references. Fault summary references are set to indicate what fault occurred. The fault reference remains on until the PLC is cleared or until cleared by the application program.

An example of a fault bit being set and then clearing the bit is shown in the following example. In this example, the coil light_01 is turned on when an oversweep condition occurs; the light and the OV_SWP contact remain on until the %I0359 contact is closed.

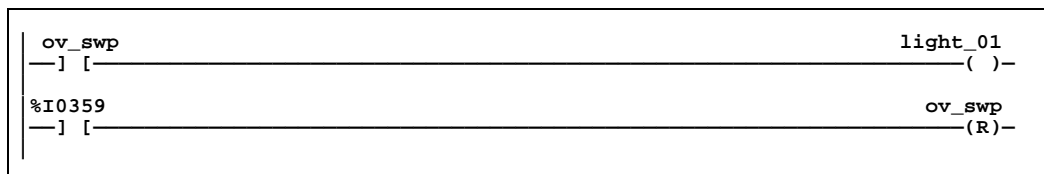

Fault Reference Definitions

The alarm processor maintains the states of the 128 system discrete bits in %S memory. These fault references can be used to indicate where a fault has occurred and what type of fault it is. Fault references are assigned to %S, %SA, %SB, and %SC memory, and they each have a nickname. These references are available for use in the application program as required. Refer to Chapter 2, “System Operation,” for a list of the system status references.

Additional Fault Effects

Two faults described previously have additional effects associated with them. These are described in the following table.

Side Effect	Description
PLC CPU Software Failure	When a PLC CPU software failure is logged, the Series 90-30CPU immediately transitions into a special ERROR SWEEP mode. No activity is permitted in this mode. The only method of clearing this condition is to reset the PLC by cycling power.
PLC Sequence Store Failure	During a sequence store (a store of program blocks and other data preceded with the special Start-of-Sequence command and ending with the End-of-Sequence command), if communications with the programming device performing the store is interrupted or any other failure occurs which terminates the download, the PLC Sequence Store Failure fault is logged. As long as this fault is present in the system, the PLC will not transition to RUN mode.

PLC Fault Table Display

The PLC Fault Table screen displays PLC faults such as password violations, PLC/configuration mismatches, parity errors, and communications errors.

The programming software may be in any operating mode. If the programming software is in **OFFLINE** mode, no faults are displayed. In **ONLINE** or **MONITOR** mode, PLC fault data is displayed. In **ONLINE** mode, faults can be cleared (this may be password protected).

Once cleared, faults that are still present are not logged again in the table (except for the “Low Battery” fault).

I/O Fault Table Display

The I/O Fault Table screen displays I/O faults such as circuit faults, address conflicts, forced circuits, and I/O bus faults.

The programming software may be in any operating mode. If the programming software is in **OFFLINE** mode, no faults are displayed. In **ONLINE** or **MONITOR** mode, I/O fault data is displayed. In **ONLINE** mode, faults can be cleared (this feature may be password protected).

Once cleared, faults that are still present are not logged again in the table.

Accessing Additional Fault Information

The fault tables contain basic information regarding the fault. Additional information pertaining to each fault can be displayed through the programming software. In addition, the programming software can provide a hexadecimal dump of the fault.

The last entry, Correction, for each fault explanation in this chapter lists the action(s) to be taken to correct the fault. Note that the corrective action for some of the faults includes the statement:

Display the PLC Fault Table on the Programmer. Contact GE Fanuc Field Service, giving them all the information contained in the fault entry.

This second statement means that you must tell Field Service both the information readable directly from the fault table **and** the hexadecimal information. Field Service personnel will then give you further instructions for the appropriate action to be taken.

Section 2: PLC Fault Table Explanations

Each fault explanation contains a fault description and instructions to correct the fault. Many fault descriptions have multiple causes. In these cases, the error code, displayed with the additional fault information, is used to distinguish different fault conditions sharing the same fault description. The error code is the first two hexadecimal digits in the fifth group of numbers, as shown in the following example.

```

01  000000  01030100  0902  0200  000000000000
                                |
                                |_____ Error Code (first two hex
                                        digits in fifth group)
  
```

Some faults can occur because random access memory on the PLC CPU board has failed. These same faults may also occur because the system has been powered off and the battery voltage is (or was) too low to maintain memory. To avoid excessive duplication of instructions when corrupted memory may be a cause of the error, the correction simply states:

Perform the corrections for Corrupted Memory.

This means:

1. If the system has been powered off, replace the battery. Battery voltage may be insufficient to maintain memory contents.
2. Replace the PLC CPU board. The integrated circuits on the PLC CPU board may be failing.

The following table enables you to quickly find a particular PLC fault explanation in this section. Each entry is listed as it appears on the programmer screen.

Fault Description	Page
Loss of, or Missing, Option Module	3-9
Reset of, Addition of, or Extra, Option Module	3-9
System Configuration Mismatch	3-10
Option Module Software Failure	3-11
Program Block Checksum Failure	3-11
Low Battery Signal	3-11
Constant Sweep Time Exceeded	3-12
Application Fault	3-12
No User Program Present	3-12
Corrupted User Program on Power-Up	3-13
Password Access Failure	3-13
PLC CPU System Software Failure	3-14
Communications Failure During Store	3-16

Fault Actions

Fatal faults cause the PLC to enter a form of **STOP** mode at the end of the sweep in which the error occurred. **Diagnostic** faults are logged and corresponding fault contacts are set.

Informational faults are simply logged in the PLC fault table.

Loss of, or Missing, Option Module

The Fault Group **Loss of, or Missing Option Module** occurs when a PCM, CMM, or ADC fails to respond. The failure may occur at power-up if the module is missing or during operation if the module fails to respond. The fault action for this group is **Diagnostic**.

Error Code:	1, 42
Name:	Option Module Soft Reset Failed
Description:	PLC CPU unable to re-establish communications with option module after soft reset.
Correction:	<ol style="list-style-type: none"> (1) Try soft reset a second time. (2) Replace the option module. (3) Power off the system. Verify that the PCM is seated properly in the rack and that all cables are properly connected and seated. (4) Replace the cables.
Error Code:	All Others
Name:	Module Failure During Configuration
Description:	The PLC operating software generates this error when a module fails during power-up or configuration store.
Correction:	<ol style="list-style-type: none"> (1) Power off the system. Replace the module located in that rack and slot.

Reset of, Addition of, or Extra, Option Module

The Fault Group **Reset of, Addition of, or Extra Option Module** occurs when an option module (PCM, ADC, etc.) comes online, is reset, or a module is found in the rack, but none is specified in the configuration. The fault action for this group is **Diagnostic**. Three bytes of fault specific data provide additional information regarding the fault.

Correction:	<ol style="list-style-type: none"> (1) Update the configuration file to include the module. (2) Remove the module from the system.
--------------------	--

System Configuration Mismatch

The Fault Group **Configuration Mismatch** occurs when the module occupying a slot is different from that specified in the configuration file. The fault action is **Fatal**.

Error Code:	1
Name:	System Configuration Mismatch
Description:	The PLC operating software generates this fault when the module occupying a slot is not of the same type that the configuration file indicates should be in that slot, or when the configured rack type does not match the actual rack present.
Correction:	Identify the mismatch and reconfigure the module or rack.
Error Code:	6
Name:	System Configuration Mismatch
Description:	This is the same as error code 1 in that this fault occurs when the module occupying a slot is not of the same type that the configuration file indicates should be in that slot, or when the configured rack type does not match the actual rack present.
Correction:	Identify the mismatch and reconfigure the module or rack.
Error Code:	18
Name:	Unsupported Hardware
Description:	A PCM or PCM-type module is present in a 311, 313, or 323, or in an expansion rack.
Correction:	Physically correct the situation by removing the PCM or PCM-type module or install a CPU that does support the PCM.
Error Code:	26
Name:	Module busy—config not yet accept by module
Description:	The module cannot accept new configuration at this time because it is busy with a different process.
Correction:	Allow the module to complete the current operation and re-store the configuration.
Error Code:	51
Name:	END Function Executed from SFC Action
Description:	The placement of an END function in SFC logic or in logic called by SFC will produce this fault.
Correction:	Remove the END function from the SFC logic or logic being called by the SFC logic.

Option Module Software Failure

The Fault Group **Option Module Software Failure** occurs when a non-recoverable software failure occurs on a PCM or ADC module. The fault action for this group is **Fatal**.

Error Code:	All
Name:	CommReq Frequency Too High
Description:	CommReqs are being sent to a module faster than it can process them.
Correction:	Change the PLC program to send CommReqs to the affected module at a slower rate.

Program Block Checksum Failure

The Fault Group **Program Block Checksum Failure** occurs when the PLC CPU detects error conditions in program blocks received by the PLC. It also occurs when the PLC CPU detects checksum errors during power-up verification of memory or during **RUN** mode background checking. The fault action for this group is **Fatal**.

Error Code:	All
Name:	Program Block Checksum Failure
Description:	The PLC Operating Software generates this error when a program block is corrupted.
Correction:	<ol style="list-style-type: none"> (1) Clear PLC memory and retry the store. (2) Display the PLC fault table on the programmer. Contact GE Fanuc PLC Field Service, giving them all the information contained in the fault entry.

Low Battery Signal

The Fault Group **Low Battery Signal** occurs when the PLC CPU detects a low battery on the PLC power supply or a module, such as the PCM, reports a low battery condition. The fault action for this group is **Diagnostic**.

Error Code:	0
Name:	Failed Battery Signal
Description:	The CPU module (or other module having a battery) battery is dead.
Correction:	Replace the battery. Do not remove power from the rack.
Error Code:	1
Name:	Low Battery Signal
Description:	A battery on the CPU, or other module has a low signal.
Correction:	Replace the battery. Do not remove power from the rack.

Constant Sweep Time Exceeded

The Fault Group **Constant Sweep Time Exceeded** occurs when the PLC CPU operates in **CONSTANT SWEEP** mode, and it detects that the sweep has exceeded the constant sweep timer. The fault extra data contains the actual time of the sweep in the first two bytes and the name of the program in the next eight bytes. The fault action for this group is **Diagnostic**.

- | | |
|--------------------|--|
| Correction: | (1) Increase constant sweep time. |
| | (2) Remove logic from application program. |

Application Fault

The Fault Group **Application Fault** occurs when the PLC CPU detects a fault in the user program. The fault action for this group is **Diagnostic**, except when the error is a Subroutine Call Stack Exceeded, in which case it is **Fatal**.

Error Code:	7
Name:	Subroutine Call Stack Exceeded
Description:	Subroutine calls are limited to a depth of 8. A subroutine can call another subroutine which, in turn, can call another subroutine until 8 call levels are attained.
Correction:	Modify program so that subroutine call depth does not exceed 8.
Error Code:	1B
Name:	CommReq Not Processed Due To PLC Memory Limitations
Description:	No-wait communication requests can be placed in the queue faster than they can be processed (for example, one per sweep). In a situation like this, when the communication requests build up to the point that the PLC has less than a minimum amount of memory available, the communication request will be faulted and not processed
Correction:	Issue fewer communication requests or otherwise reduce the amount of mail being exchanged within the system.
Error Code:	5A
Name:	User Shut Down Requested
Description:	The PLC operating software (function blocks) generates this informational alarm when Service Request #13 (User Shut Down) executes in the application program.
Correction:	None required. Information-only alarm.

No User Program Present

The Fault Group **No User Program Present** occurs when the PLC CPU is instructed to transition from **STOP** to **RUN** mode or a store to the PLC and no user program exists in the PLC. The PLC CPU detects the absence of a user program on power-up. The fault action for this group is **Informational**.

Correction:	Download an application program before attempting to go to RUN mode.
--------------------	---

Corrupted User Program on Power-Up

The Fault Group **Corrupted User Program on Power-Up** occurs when the PLC CPU detects corrupted user RAM. The PLC CPU will remain in **STOP** mode until a valid user program and configuration file are downloaded. The fault action for this group is **Fatal**.

Error Code:	1
Name:	Corrupted User RAM on Power-Up
Description:	The PLC operating software (operating software) generates this error when it detects corrupted user RAM on power-up.
Correction:	<ol style="list-style-type: none"> (1) Reload the configuration file, user program, and references (if any). (2) Replace the battery on the PLC CPU. (3) Replace the expansion memory board on the PLC CPU. (4) Replace the PLC CPU.
Error Code:	2
Name:	Illegal Boolean OpCode Detected
Description:	The PLC operating software (operating software) generates this error when it detects a bad instruction in the user program.
Correction:	<ol style="list-style-type: none"> (1) Restore the user program and references (if any). (2) Replace the expansion memory board on the PLC CPU. (3) Replace the PLC CPU.

Password Access Failure

The Fault Group **Password Access Failure** occurs when the PLC CPU receives a request to change to a new privilege level and the password included with the request is not valid for that level. The fault action for this group is **Informational**.

Correction:	Retry the request with the correct password.
--------------------	--

PLC CPU System Software Failure

The operating software of the Series 90-30 CPU generates Faults in the Fault Group **PLC CPU System Software Failure**. They occur at many different points of system operation. When a **Fatal** fault occurs, the PLC CPU **immediately** transitions into a special **ERROR SWEEP** mode. No activity is permitted when the PLC is in this mode. The only way to clear this condition is to cycle power on the PLC. The fault action for this group is **Fatal**.

Error Code:	1 through B
Name:	User Memory Could Not Be Allocated
Description:	The PLC operating software (memory manager) generates these errors when software requests the memory manager to allocate or de-allocate a block or blocks of memory from user RAM that are not legal. These errors should <i>not</i> occur in a production system.
Correction:	Display the PLC fault table on the programmer. Contact GE Fanuc PLC Field Service, giving them all the information contained in the fault entry.
Error Code:	D
Name:	System Memory Unavailable
Description:	The PLC operating software (I/O Scanner) generates this error when its request for a block of system memory is denied by the memory manager because no memory is available from the system memory heap. It is <i>Informational</i> if the error occurs during the execution of a DO I/O function block. It is <i>Fatal</i> if it occurs during power-up initialization or autoconfiguration.
Correction:	Display the PLC fault table on the programmer. Contact GE Fanuc PLC Field Service, giving them all the information contained in the fault entry.
Error Code:	E
Name:	System Memory Could Not Be Freed
Description:	The PLC operating software (I/O Scanner) generates this error when it requests the memory manager to de-allocate a block of system memory and the de-allocation fails. This error can only occur during the execution of a DO I/O function block.
Correction:	<ol style="list-style-type: none"> (1) Display the PLC fault table on the programmer. Contact GE Fanuc PLC Field Service, giving them all the information contained in the fault entry. (2) Perform the corrections for corrupted memory.
Error Code:	10
Name:	Invalid Scan Request of the I/O Scanner
Description:	The PLC operating software (I/O Scanner) generates this error when the operating system or DO I/O function block scan requests neither a full nor a partial scan of the I/O. This should <i>not</i> occur in a production system.
Correction:	Display the PLC fault table on the programmer. Contact GE Fanuc PLC Field Service, giving them all the information contained in the fault entry.
Error Code:	13
Name:	PLC Operating Software Error
Description:	The PLC operating software generates this error when certain PLC operating software problems occur. This error should <i>not</i> occur in a production system.
Correction:	<ol style="list-style-type: none"> (1) Display the PLC fault table on the programmer. Contact GE Fanuc PLC Field Service, giving them all the information contained in the fault entry. (2) Perform the corrections for corrupted memory.

Error Code:	14, 27
Name:	Corrupted PLC Program Memory
Description:	The PLC operating software generates these errors when certain PLC operating software problems occur. These should <i>not</i> occur in a production system.
Correction:	<ol style="list-style-type: none"> (1) Display the PLC fault table on the programmer. Contact GE Fanuc PLC Field Service, giving them all the information contained in the fault entry. (2) Perform the corrections for corrupted memory.
Error Code:	27 through 4E
Name:	PLC Operating Software Error
Description:	The PLC operating software generates these errors when certain PLC operating software problems occur. These errors should <i>not</i> occur in a production system.
Correction:	Display the PLC fault table on the programmer. Contact GE Fanuc PLC Field Service, giving them all the information contained in the fault entry.
Error Code:	4F
Name:	Communications Failed
Description:	The PLC operating software (service request processor) generates this error when it attempts to comply with a request that requires backplane communications and receives a rejected response.
Correction:	<ol style="list-style-type: none"> (1) Check the bus for abnormal activity. (2) Replace the intelligent option module to which the request was directed.
Error Code:	50, 51, 53
Name:	System Memory Errors
Description:	The PLC operating software generates these errors when its request for a block of system memory is denied by the memory manager because no memory is available or contains errors.
Correction:	<ol style="list-style-type: none"> (1) Display the PLC fault table on the programmer. Contact GE Fanuc PLC Field Service, giving them all the information contained in the fault entry. (2) Perform the corrections for corrupted memory.
Error Code:	52
Name:	Backplane Communications Failed
Description:	The PLC operating software (service request processor) generates this error when it attempts to comply with a request that requires backplane communications and receives a rejected mail response.
Correction:	<ol style="list-style-type: none"> (1) Check the bus for abnormal activity. (2) Replace the intelligent option module to which the request was directed. (3) Check parallel programmer cable for proper attachment.
Error Code:	All Others
Name:	PLC CPU Internal System Error
Description:	An internal system error has occurred that should not occur in a production system.
Correction:	Display the PLC fault table on the programmer. Contact GE Fanuc PLC Field Service, giving them all the information contained in the fault entry.

Communications Failure During Store

The Fault Group **Communications Failure During Store** occurs during the store of program blocks and other data to the PLC. The stream of commands and data for storing program blocks and data starts with a special start-of-sequence command and terminates with an end-of-sequence command. If communications with the programming device performing the store is interrupted or any other failure occurs which terminates the load, this fault is logged. As long as this fault is present in the system, the controller will not transition to **RUN** mode.

This fault is *not* automatically cleared on power-up; the user must specifically order the condition to be cleared. The fault action for this group is **Fatal**.

Correction: Clear the fault and retry the download of the program or configuration file.

Section 3: I/O Fault Table Explanations

The I/O fault table reports data about faults in three classifications:

- Fault category.
- Fault type.
- Fault description.

The faults described on the following page have a fault category, but do not have a fault type or fault group.

Each fault explanation contains a fault description and instructions to correct the fault. Many fault descriptions have multiple causes. The Fault Category is the first two hexadecimal digits in the fifth group of numbers, as shown in the following example.

```
02 1F0100 00030101FF7F 0302 0200 840000000000003
                                |
                                _____ Fault Category (first two hex
                                           digits in fifth group)
```

The following table enables you to quickly find a particular I/O fault explanation in this section. Each entry is listed as it appears on the programmer screen.

Loss of I/O Module

The Fault Category **Loss of I/O Module** applies to Series 90-30 discrete and analog I/O modules. There are no fault types or fault descriptions associated with this category. The fault action is **Diagnostic**.

Description:	The PLC operating software generates this error when it detects that a Model 30 I/O module is no longer responding to commands from the PLC CPU, or when the configuration file indicates an I/O module is to occupy a slot and no module exists in the slot.
Correction:	<ol style="list-style-type: none">(1) Replace the module.(2) Correct the configuration file.(3) Display the PLC fault table on the programmer. Contact GE Fanuc PLC Field Service, giving them all the information contained in the fault entry.

Addition of I/O Module

The Fault Category **Addition of I/O Module** applies to Series 90-30 discrete and analog I/O modules. There are no fault types or fault descriptions associated with this category. The fault action is **Diagnostic**.

Description:	The PLC operating software generates this error when an I/O module, which had been, faulted returns to operation.
Correction:	(1) No action necessary if the module was removed or replaced, or the remote rack was power cycled. (2) Update the configuration file or remove the module.
Description:	The PLC operating software generates this error when it detects a Series 90-30 I/O module in a slot that the configuration file indicates should be empty.
Correction:	(1) Remove the module. (It may be in the wrong slot.) (2) Update and restore the configuration file to include the extra module.

The Series 9030 PLCs support many different functions and function blocks. This appendix contains tables showing the memory size in bytes and the execution time in microseconds for each function. Memory size is the number of bytes required by the function in a ladder diagram application program.

Two execution times are shown for each function:

Execution Time	Description
Enabled	Time required to execute the function or function block when power flows into and out of the function. Typically, best-case times are when the data used by the block is contained in user RAM (word-oriented memory) and not in the ISCP cache memory (discrete memory).
Disabled	Time required to execute the function when power flows into the function or function block; however, it is in an inactive state, as when a timer is held in the reset state.

Note

Timers and counters are updated each time they are encountered in the logic, timers by the amount of time consumed by the last sweep and counters by one count.

Note

For the 350, 351, 352, and 36x PLC CPUs, times are identical except for the MOVE instruction, which is different for the 350 CPU—refer to the note at the bottom of the table on page A-6.

Instruction Timing Tables

Table A-1. Instruction Timing, Standard Models

Function Group	Function	Enabled				Disabled				Increment				Size
		311	313	331	340/41	311	313	331	340/41	311	313	331	340/41	
Timers	OnDelay Timer	146	81	80	42	105	39	38	21	–	–	–	–	15
	OffDelay Timer	98	47	44	23	116	63	58	32	–	–	–	–	9
	Timer	122	76	75	40	103	54	53	30	–	–	–	–	15
Counters	Up Counter	137	70	69	36	130	63	62	33	–	–	–	–	11
	Down Counter	136	70	69	37	127	61	61	31	–	–	–	–	11
Math	Addition (INT)	76	47	46	24	41	0	1	0	–	–	–	–	13
	Addition (DINT)	90	60	60	34	41	1	0	0	–	–	–	–	13
	Subtraction (INT)	75	46	45	25	41	0	1	0	–	–	–	–	13
	Subtraction (DINT)	92	62	62	34	41	1	0	0	–	–	–	–	13
	Multiplication (INT)	79	49	50	28	41	0	1	0	–	–	–	–	13
	Multiplication (DINT)	108	80	101	43	41	1	0	0	–	–	–	–	13
	Division (INT)	79	51	50	27	41	0	1	0	–	–	–	–	13
	Division (DINT)	375	346	348	175	41	1	0	0	–	–	–	–	13
	Modulo Division (INT)	78	51	49	27	41	0	1	0	–	–	–	–	13
	Modulo Div (DINT)	134	103	107	54	41	1	0	0	–	–	–	–	13
	Square Root (INT)	153	124	123	65	42	0	1	0	–	–	–	–	9
Square Root (DINT)	268	239	241	120	42	0	0	1	–	–	–	–	9	
Relational	Equal (INT)	66	35	36	19	41	1	1	0	–	–	–	–	9
	Equal (DINT)	86	56	54	29	41	1	0	0	–	–	–	–	9
	Not Equal (INT)	67	39	35	22	41	1	1	0	–	–	–	–	9
	Not Equal (DINT)	81	51	51	28	41	1	0	0	–	–	–	–	9
	Greater Than (INT)	64	33	35	20	41	1	1	0	–	–	–	–	9
	Greater Than (DINT)	89	59	58	32	41	1	0	0	–	–	–	–	9
	Greater Than/Eq (INT)	64	36	34	19	41	1	1	0	–	–	–	–	9
	Greater Than/Eq (DINT)	87	58	57	30	41	1	0	0	–	–	–	–	9
	Less Than (INT)	66	35		19	41	1	1	0	–	–	–	–	9
	Less Than (DINT)	87	57		30	41	1	1	0	–	–	–	–	9
	Less Than/Equal (INT)	66	36	34	21	41	1	1	0	–	–	–	–	9
	Less Than/Equal (DINT)	86	57	56	31	41	1	1	0	–	–	–	–	9
	Range (INT)	92	58	54	29	46	1	0	1	–	–	–	–	15
	Range(DINT)	106	75	57	37	45	0	0	0	–	–	–	–	15
	Range(WORD)	93	60	54	29	0	0	0	0	–	–	–	–	15

- Notes:**
1. Time (in microseconds) is based on Release 5.01 of Logicmaster 9030/20 software for Models 311, 313, 340, and 341 CPUs (Release 7 for the 331).
 2. For table functions, increment is in units of length specified.; for bit operation functions, microseconds/bit.; for data move functions, microseconds/number of bits or words.
 3. Enabled time for single length units of type %R, %AI, and %AQ.
 4. COMMREQ time has been measured between CPU and HSC.
 5. DOIO is the time to output values to discrete output module.
 6. Where there is more than one possible case, the time indicated above represents the worst possible case.

Table A-1. Instruction Timing, Standard Models-Continued

Function Group	Function	Enabled				Disabled				Increment				Size
		311	313	331	340/41	311	313	331	340/41	311	313	331	340/41	
Bit Operation	Logical AND	67	37	37	22	42	0	0	1	–	–	–	–	13
	Logical OR	68	38	38	21	42	0	0	1	–	–	–	–	13
	Logical Exclusive OR	66	38	37	20	42	0	1	1	–	–	–	–	13
	Logical Invert, NOT	62	32	31	17	42	0	1	1	–	–	–	–	9
	Shift Bit Left	139	89	90	47	74	26	23	13	11.61	11.61	12.04	6.29	15
	Shift Bit Right	135	87	85	45	75	26	24	13	11.63	11.62	12.02	6.33	15
	Rotate Bit Left	156	127	126	65	42	1	1	0	11.70	11.78	12.17	6.33	15
	Rotate Bit Right	146	116	116	62	42	1	1	0	11.74	11.74	12.13	6.27	15
	Bit Position	102	72	49	38	42	1	0	0	–	–	–	–	13
	Bit Clear	68	38	35	21	42	1	1	1	–	–	–	–	13
	Bit Test	79	49	51	28	41	0	0	1	–	–	–	–	13
	Bit Set	67	37	37	20	42	0	0	0	–	–	–	–	13
	Masked Compare (WORD)	217	154	141	74	107	44	39	21	–	–	–	–	25
	Masked Compare (DWORD)	232	169	156	83	108	44	39	22	–	–	–	–	25
Data Move	Move (INT)	68	37	39	20	43	0	0	0	1.62	1.62	5.25	1.31	13
	Move (BIT)	94	62	64	35	42	0	0	0	12.61	12.64	12.59	6.33	13
	Move (WORD)	67	37	40	20	41	0	0	0	1.62	1.63	5.25	1.31	13
	Block Move (INT)	76	48	50	28	59	30	30	16	–	–	–	–	27
	Block Move (WORD)	76	48	49	29	59	29	28	15	–	–	–	–	27
	Block Clear	56	28	27	14	43	0	0	0	1.35	1.29	1.40	0.78	9
	Shift Register (BIT)	201	153	153	79	85	36	34	18	0.69	0.68	0.71	0.37	15
	Shift Register (WORD)	103	53	52	29	73	25	23	12	1.62	1.62	2.03	1.31	15
	Bit Sequencer	165	101	99	53	96	31	29	16	0.07	0.07	0.08	0.05	15
	COMM_REQ	1317	1272	1489	884	41	2	0	0	–	–	–	–	13
Table	Array Move													
	INT	230	201	177	104	72	41	40	20	1.29	1.15	10.56	2.06	21
	DINT	231	202	181	105	74	44	42	23	3.24	3.24	10.53	2.61	21
	BIT	290	261	229	135	74	43	42	23	–.03	–.03	–0.01	0.79	21
	BYTE	228	198	176	104	74	42	42	23	0.81	0.82	8.51	1.25	21
	WORD	230	201	177	104	72	41	40	20	1.29	1.15	10.56	2.06	21
	Search Equal													
	INT	197	158	123	82	78	39	37	20	1.93	1.97	2.55	1.55	19
	DINT	206	166	135	87	79	38	36	21	4.33	4.34	4.55	2.44	19
	BYTE	179	141	117	74	78	38	36	21	1.53	1.49	1.83	1.03	19
WORD	197	158	123	82	78	39	37	20	1.93	1.97	2.55	1.55	19	

- Notes:**
1. Time (in microseconds) is based on Release 5.01 of Logicmaster 9030/20 software for Models 311, 313, 340, and 341 CPUs (Release 7 for the 331).
 2. For table functions, increment is in units of length specified.; for bit operation functions, microseconds/bit.; for data move functions, microseconds/number of bits or words.
 3. Enabled time for single length units of type %R, %AI, and %AQ.
 4. COMMREQ time has been measured between CPU and HSC.
 5. DOIO is the time to output values to discrete output module.
 6. Where there is more than one possible case, the time indicated above represents the worst possible case.
 7. For instructions that have an increment value, multiply the increment by (Length – 1) and add that value to the base time.

Table A-1. Instruction Timing, Standard Models-Continued

Function Group	Function	Enabled				Disabled				Increment				Size
		311	313	331	340/41	311	313	331	340/41	311	313	331	340/41	
	Search Not Equal													
	INT	198	159	124	83	79	39	36	21	1.93	1.93	2.48	1.52	19
	DINT	201	163	132	84	79	37	35	21	6.49	6.47	6.88	3.82	19
	BYTE	179	141	117	73	79	38	36	19	1.54	1.51	1.85	1.05	19
	WORD	198	159	124	83	79	39	36	21	1.93	1.93	2.48	1.52	19
	Search Greater Than													
	INT	198	160	125	82	79	37	38	19	3.83	3.83	4.41	2.59	19
	DINT	206	167	135	88	78	38	36	20	8.61	8.61	9.03	4.88	19
	BYTE	181	143	118	73	79	37	36	19	3.44	3.44	3.75	2.03	19
	WORD	198	160	125	82	79	37	38	19	3.83	3.83	4.41	2.59	19
	Search Greater Than/Eq													
	INT	197	160	124	83	77	38	36	20	3.86	3.83	4.45	2.52	19
	DINT	205	167	136	87	80	39	36	21	8.62	8.61	9.02	4.87	19
	BYTE	180	142	118	75	79	37	37	20	3.47	3.44	3.73	2.00	19
	WORD	197	160	124	83	77	38	36	20	3.86	3.83	4.45	2.52	19
	Search Less Than													
	INT	199	159	124	84	78	38	36	20	3.83	3.86	4.48	2.48	19
	DINT	206	168	135	87	79	38	38	19	8.62	8.60	-1.36	4.88	19
	BYTE	181	143	119	75	80	38	37	20	3.44	3.44	3.75	2.00	19
	WORD	199	159	124	84	78	38	36	20	3.83	3.86	4.45	2.48	19
Search Less Than/Equal														
INT	200	158	124	82	79	38	37	21	3.79	3.90	4.45	2.55	19	
DINT	207	167	137	88	78	39	37	19	8.60	8.61	9.01	4.86	19	
BYTE	180	143	119	74	78	40	37	19	3.46	3.44	3.73	2.02	19	
WORD	200	158	124	82	79	38	37	21	3.79	3.90	4.45	2.55	19	
Conversion	Convert to INT	74	46	39	25	42	1	1	1	–	–	–	–	9
	Convert to BCD-4	77	50	34	25	42	1	1	1	–	–	–	–	9

- Notes:**
1. Time (in microseconds) is based on Release 5.01 of Logicmaster 9030/20 software for Models 311, 313, 340, and 341 CPUs (Release 7 for the 331).
 2. For table functions, increment is in units of length specified.; for bit operation functions, microseconds/bit.; for data move functions, microseconds/number of bits or words.
 3. Enabled time for single length units of type %R, %AI, and %AQ.
 4. COMMREQ time has been measured between CPU and HSC.
 5. DOIO is the time to output values to discrete output module.
 6. Where there is more than one possible case, the time indicated above represents the worst possible case.
 7. For instructions that have an increment value, multiply the increment by (Length-1) and add that value to the base time.

Table A-1. Instruction Timing, Standard Models-Continued

Function Group	Function	Enabled				Disabled				Increment				Size
		311	313	331	340/41	311	313	331	340/41	311	313	331	340/41	
Control	Call a Subroutine	155	93	192	85	41	0	0	0	-	-	-	-	7
	Do I/O	309	278	323	177	38	1	0	0	-	-	-	-	12
	PID – ISA Algorithm	1870	1827	1812	929	91	56	82	30	-	-	-	-	15
	PID – IND Algorithm	2047	2007	2002	1017	91	56	82	30	-	-	-	-	15
	End Instruction	-	-	-	-	-	-	-	-	-	-	-	-	-
	Service Request													
	# 6	93	54	63	45	41	2	0	0	-	-	-	-	9
	# 7 (Read)	-	37	309	161	-	2	0	0	-	-	-	-	9
	# 7 (Set)	-	37	309	161	-	2	0	0	-	-	-	-	9
	#14	447	418	483	244	41	2	0	0	-	-	-	-	9
	#15	281	243	165	139	41	2	0	0	-	-	-	-	9
	#16	131	104	115	69	41	2	0	0	-	-	-	-	9
	#18	-	56	300	180	-	2	0	0	-	-	-	-	9
	#23	1689	1663	1591	939	43	1	0	0	-	-	-	-	9
#26//30*	1268	1354	6680	3538	42	0	0	0	-	-	-	-	9	
#29	-	-	55	41	-	-	1	0	-	-	-	-	9	
Nested MCR/ENDMCR Combined	135	73	68	39	75	25	21	12	-	-	-	-	8	

*Service request #26/30 was measured using a high speed counter, 16point output, in a 5slot rack.

- Notes:**
1. Time (in microseconds) is based on Release 5.01 of Logicmaster 9030/20 software for Models 311, 313, 340, and 341 CPUs (Release 7 for the 331).
 2. For table functions, increment is in units of length specified.; for bit operation functions, microseconds/bit.; for data move functions, microseconds/number of bits or words.
 3. Enabled time for single length units of type %R, %AI, and %AQ.
 4. COMMREQ time has been measured between CPU and HSC.
 5. DOIO is the time to output values to discrete output module.
 6. Where there is more than one possible case, the time indicated above represents the worst possible case.
 7. For instructions that have an increment value, multiply the increment by (Length-1) and add that value to the base time.

Table A-2. Instruction Timing, High Performance Models

Function Group	Function	Enabled	Disabled	Increment	Enabled	Disabled	Increment	Size
		350/351/36x	350/351/36x	350/351/36x	352	352	352	
Timers	On-Delay Timer	4	6	–	4	5	–	15
	Timer	3	3	–	2	2	–	15
	Off-Delay Timer	3	3	–	3	2	–	15
Counters	Up Counter	1	3	–	2	2	–	13
	Down Counter	3	3	–	1	2	–	13
Math	Addition (INT)	2	0	–	1	0	–	13
	Addition (DINT)	2	0	–	2	0	–	19
	Addition (REAL)	52	0	–	33	0	–	17
	Subtraction (INT)	2	0	–	1	0	–	13
	Subtraction (DINT)	2	0	–	2	0	–	19
	Subtraction (REAL)	53	0	–	34	0	–	17
	Multiplication (INT)	21	0	–	21	0	–	13
	Multiplication (DINT)	24	0	–	24	0	–	19
	Multiplication (REAL)	68	1	–	38	1	–	17
	Division (INT)	22	0	–	22	0	–	13
	Division (DINT),	25	0	–	25	0	–	19
	Division (REAL)	82	2	–	36	2	–	17
	Modulo Division (INT)	21	0	–	21	0	–	13
	Modulo Div (DINT)	25	0	–	25	0	–	19
	Square Root (INT)	42	1	–	41	1	–	10
	Square Root (DINT)	70	0	–	70	0	–	13
Square Root (REAL)	137	0	–	35	0	–	11	
Trigonometric	SIN (REAL)	360	0	–	32	0	–	11
	COS (REAL)	319	0	–	29	0	–	11
	TAN (REAL)	510	1	–	32	1	–	11
	ASIN (REAL)	440	0	–	45	0	–	11
	ACOS (REAL)	683	0	–	63	0	–	11
	ATAN (REAL)	264	1	–	33	1	–	11
Logarithmic	LOG (REAL)	469	0	–	32	0	–	11
	LN (REAL)	437	0	–	32	0	–	11
Exponential	EXP	639	0	–	42	0	–	11
	EXPT	89	1	–	54	1	–	17
Radian Conversion	Convert RAD to DEG	65	1	–	32	1	–	11
	Convert DEG to RAD	59	0	–	32	0	–	11

- Notes:**
1. Time (in microseconds) is based on Release 7 of Logicmaster 90-30/20/Micro software for Model 351 and 352 CPUs.
 2. For table functions, increment is in units of length specified.; for bit operation functions, microseconds/bit.; for data move functions, microseconds/number of bits or words.
 3. Enabled time for single length units of type %R, %AI, and %AQ.
 4. COMMREQ time has been measured between CPU and HSC.
 5. DOIO is the time to output values to discrete output module.
 6. Where there is more than one possible case, the time indicated above represents the worst possible case.

Table A-2. Instruction Timing, High Performance Models-Continued

Function Group	Function	Enabled	Disabled	Increment	Enabled	Disabled	Increment	Size
		350/351/36x	350/351/36x	350/351/36x	352	352	352	
Relational	Equal (INT)	1	0	–	1	0	–	10
	Equal (DINT)	2	0	–	2	0	–	16
	Equal (REAL)	57	0	–	28	0	–	14
	Not Equal (INT)	1	0	–	1	0	–	10
	Not Equal (DINT)	1	0	–	1	0	–	16
	Not Equal (REAL)	62	0	–	31	0	–	14
	Greater Than (INT)	1	0	–	1	0	–	10
	Greater Than (DINT)	1	0	–	1	0	–	16
	Greater Than (REAL)	57	0	–	32	0	–	14
	Greater Than/Equal (INT)	1	0	–	1	0	–	10
	Greater Than/Equal (DINT)	1	0	–	1	0	–	10
	Greater Than/Equal (REAL)	57	1	–	31	1	–	14
	Less Than (INT)	1	0	–	1	0	–	10
	Less Than (DINT)	1	0	–	1	0	–	16
	Less Than (REAL)	58	1	–	36	1	–	14
	Less Than/Equal (INT)	1	0	–	1	0	–	10
	Less Than/Equal (DINT)	3	0	–	3	0	–	16
	Less Than/Equal (REAL)	37	0	–	37	0	–	14
	Range (INT)	2	1	–	2	1	–	13
	Range (DINT)	2	1	–	2	1	–	22
Range (WORD)	1	0	–	1	0	–	13	
Bit Operation	Logical AND	2	0	–	2	0	–	13
	Logical OR	2	0	–	2	0	–	13
	Logical Exclusive OR	1	0	–	1	0	–	13
	Logical Invert, NOT	1	0	–	1	0	–	10
	Shift Bit Left	31	1	1.37	31	1	1.37	16
	Shift Bit Right	28	0	3.03	28	0	3.03	16
	Rotate Bit Left	25	0	3.12	25	0	3.12	16
	Rotate Bit Right	25	0	4.14	25	0	4.14	16
	Bit Position	20	1	–	20	1	–	13
	Bit Clear	20	0	–	20	0	–	13
	Bit Test	20	0	–	20	0	–	13
	Bit Set	19	1	–	19	1	–	13
	Mask Compare (WORD)	52	0	–	52	0	–	25
	Mask Compare (DWORD)	50	0	–	49	0	–	25

- Notes:**
1. Time (in microseconds) is based on Release 7 of Logicmaster 90-30/20/Micro software for Model 351 and 352 CPUs.
 2. For table functions, increment is in units of length specified.; for bit operation functions, microseconds/bit.; for data move functions, microseconds/number of bits or words.
 3. Enabled time for single length units of type %R, %AI, and %AQ.
 4. COMMREQ time has been measured between CPU and HSC.
 5. DOIO is the time to output values to discrete output module.
 6. Where there is more than one possible case, the time indicated above represents the worst possible case.
 7. For instructions that have an increment value, multiply the increment by (Length–1) and add that value to the base time.

Table A-2. Instruction Timing, High Performance Models-Continued

Function Group	Function	Enabled	Disabled	Increment	Enabled	Disabled	Increment	Size
		350/351/36X	350/351/36X	350/351/36X	352	352	352	
Data Move	Move (INT)	2	0	0.41	2	0	0.41	10
	Move (BIT)	28	0	4.98	28	0	4.98	13
	Move (WORD)	2	0	0.41	2	0	0.41	10
	Move (REAL)	24	1	0.82	24	1	0.82	13
	Block Move (INT)	2	0	–	2	0	–	28
	Block Move (WORD)	4	4	–	3	0	–	28
	Block Move (REAL)	41	0	–	41	0	–	13
	Block Clear	1	0	0.24	1	0	0.24	11
	Shift Register (BIT)	49	0	0.23	46	0	0.23	16
	Shift Register (WORD)	27	0	0.41	27	0	0.41	16
	Bit Sequencer	38	22	0.02	38	22	0.02	16
COMM_REQ	765	0	–	765	0	–	13	
Table	Array Move							
	INT	54	0	0.97	54	0	0.97	22
	DINT	54	0	0.81	54	0	0.81	22
	BIT	69	0	0.36	69	0	0.36	22
	BYTE	54	1	0.64	54	1	0.64	22
	WORD	54	0	0.97	54	0	0.97	22
	Search Equal							
	INT	37	0	0.62	37	0	0.62	19
	DINT	41	1	1.38	41	1	1.38	22
	BYTE	35	0	0.46	35	0	0.46	19
	WORD	37	0	0.62	37	0	0.62	19
	Search Not Equal							
	INT	37	0	0.62	37	0	0.62	19
	DINT	38	0	2.14	38	0	2.14	22
	BYTE	37	0	0.47	37	0	0.47	19
	WORD	37	0	0.62	37	0	0.62	19
	Search Greater Than							
	INT	37	0	1.52	37	0	1.52	19
	DINT	39	0	2.26	39	0	2.26	22
	BYTE	36	1	1.24	36	1	1.24	19
	WORD	37	0	1.52	37	0	1.52	19
	Search Greater Than/Equal							
	INT	37	0	1.48	37	0	1.48	19
	DINT	39	0	2.33	39	0	2.33	22
	BYTE	37	1	1.34	37	1	1.34	19
	WORD	37	0	1.48	37	0	1.48	19

- Notes:**
1. Time (in microseconds) is based on Release 7 of Logicmaster 90-30/20/Micro software for 350 and 360 Series CPUs.
 2. For table functions, increment is in units of length specified.; for bit operation functions, microseconds/bit.; for data move functions, microseconds/number of bits or words.
 3. Enabled time for single length units of type %R, %AI, and %AQ.
 4. COMMREQ time has been measured between CPU and HSC.
 5. DOIO is the time to output values to discrete output module.
 6. Where there is more than one possible case, the time indicated above represents the worst possible case.
 7. For instructions that have an increment value, multiply the increment by (Length – 1) and add that value to the base time.

Table A-2. Instruction Timing, High Performance Models-Continued

Function Group	Function	Enabled	Disabled	Increment	Enabled	Disabled	Increment	Size
		350/351/36x	350/351/36x	350/351/36x	352	352	352	
	Search Less Than							
	INT	37	0	1.52	37	0	1.52	19
	DINT	41	1	2.27	41	1	2.27	22
	BYTE	37	0	1.41	37	0	1.41	19
	WORD	37	0	1.52	37	0	1.52	19
	Search Less Than/Equal							
	INT	38	0	1.48	38	0	1.48	19
	DINT	40	1	2.30	40	1	2.30	22
Conversion	Convert to INT	19	1	–	19	1	–	10
	Convert to BCD-4	21	1	–	21	1	–	10
	Convert to REAL	27	0	–	21	0	–	8
	Convert to WORD	28	1	–	30	1	–	11
	Truncate to INT	32	0	–	32	0	–	11
	Truncate to DINT	63	0	–	31	0	–	11
Control	Call a Subroutine	72	1	–	73	1	–	7
	Do I/O	114	1	–	115	1	–	13
	PID – ISA Algorithm*	162	34	–	162	34	–	16
	PID – IND Algorithm*	146	34	–	146	34	–	16
	End Instruction	–	–	–	–	–	–	–
	Service Request							
	#6	22	1	–	22	1	–	10
	#7 (Read)	75	1	–	75	1	–	10
	#7 (Set)	75	1	–	75	1	–	10
	#14	121	1	–	121	1	–	10
	#15	46	1	–	46	1	–	10
	#16	36	1	–	36	1	–	10
	#18	261	1	–	261	1	–	10
	#23	426	0	–	426	0	–	10
	#26//30**	2260	1	–	2260	1	–	10
#29	20	0	–	20	0	–	10	
#43								
Nested MCR/ENDMCR Combined	1	1	–	1	1	–	4	
Sequential Event Recorder (SER)	See Table A-3	26.50	See Table A-3					

*The PID times shown above are based on the 6.5 release of the 351 CPU.

**Service request #26/30 was measured using a high speed counter, 16-point output, in a 5-slot rack.

- Notes:**
1. Time (in microseconds) is based on Release 7 of Logicmaster 90-30/20/Micro software for 350 and 360 Series CPUs.
 2. For table functions, increment is in units of length specified.; for bit operation functions, microseconds/bit.; for data move functions, microseconds/number of bits or words.
 3. Enabled time for single length units of type %R, %AI, and %AQ.
 4. COMMREQ time has been measured between CPU and HSC.
 5. DOIO is the time to output values to discrete output module.
 6. Where there is more than one possible case, the time indicated above represents the worst possible case.
 7. For instructions that have an increment value, multiply the increment by (Length – 1) and add that value to the base time.

Table A-3. SER Function Block Timing

Configuration	Example	Time (μsec)
No power flow (disabled)	—	26.50
Contiguous		
8 samples	%I1—8	79.94
16 samples	%I1—16	80.58
24 samples	%I1—24	81.56
32 samples	%I1—32	81.73
8 + 8 contiguous samples	%I1—8 and %Q1—8	111.03
8 + 8 + 8 contiguous samples	%I1—8, %Q1—8 and %M1—8	143.38
8 + 8 + 8 + 8 contiguous samples	%I1—8, %Q1—8 and %M1—8 and %T1—8	175.79
Noncontiguous		
8 samples	%I1, %M10, %Q3, etc.	299.64
16 samples		552.83
24 samples		806.35
32 samples		1059.85
Reset		
with 8 samples	—	162.63
with 16 samples	—	267.51
with 24 samples	—	372.73
with 32 samples	—	477.95

Notes: Increment for specifying an Input module: +46 μsec
Increment for each group of 8 contiguous samples: +32 μsec
Increment for each group of 8 noncontiguous samples: +254 μsec
Increment for trigger sample using BCD format: +29 μsec
Increment for trigger sample using Posix format: +148 μsec
Times shown for reset are for the maximum buffer size of 1024 samples. (Reset clears all samples in the sample buffer.)

Table A-4. SER Function Block Trigger Timestamp Formats

Example trigger time of November 3, 1998 at 8:34:05:16 a.m.

BCD Format:

```

struct time_of_day_clk_rec {
    unsigned char  seconds;
    unsigned char  minutes;
    unsigned char  hours;
    unsigned char  day_of_month;
    unsigned char  month;
    unsigned char  year;
};
    
```

Register	Parameter	Value (dec)	Value (hex)
%R0203	Minutes/Seconds	13317	3405
%R204	Day of Month/Hours	776	0308
%R205	Year/Month	-26607	9811
%R206	Unused	0	0

POSIX Format:

```

struct timespec {
    long  tv_sec; /* Number of seconds since January 1, 1970 */
    long  tv_nsec; /* Number of nanoseconds into next seconds */
};
    
```

Register	Parameter	Value (dec)	Value (hex)
%R0203	Seconds Low Word	-7811	e17d
%R204	Seconds High Word	13845	3615
%R205	Nano-seconds Low Word	26624	6800
%R206	Nano-seconds High Word	2441	0989

Instruction Sizes for High Performance CPUs

Memory size is the number of bytes required by the instruction in a ladder diagram application program. Model 351 and 352 CPUs require three bytes for most standard Boolean functions—see Table A-3.

Table A-5. Instruction Sizes for 350—352, 360, 363, and 364 CPUs

Function	Size
No operation	1
Pop stack and AND to top	1
Pop stack and OR to top	1
Duplicate top of stack	1
Pop stack	1
Initial stack	1
Label	5
Jump	5
All other instructions	3
Function blocks—see Table A-2	–

Boolean Execution Times

The table below lists execution times of coils and contacts for the Series 90-30 CPU modules.

Table A-5. Boolean Execution Times

CPU Model	Execution Time per 1,000 Boolean Contacts/Coils
Model 350 and 360 Series	0.22 milliseconds
Model 340/341	0.3 milliseconds
Model 331	0.4 milliseconds
Model 313/323	0.6 milliseconds
Model 311	18.0 milliseconds

Appendix *B*

Interpreting Fault Tables

The Series 90-30 PLCs maintain two fault tables, the I/O fault table for faults generated by I/O devices (including I/O controllers) and the PLC fault table for internal PLC faults. The information in this appendix will enable you to interpret the message structure format when reading these fault tables. Both tables contain similar information.

- The PLC fault table contains:
 - Fault location.
 - Fault description.
 - Date and time of fault.
- The I/O fault table contains:
 - Fault location.
 - Reference address.
 - Fault category.
 - Fault type.
 - Date and time of fault.

PLC Fault Table

Access the PLC fault table through the programming software. For information about accessing fault tables, refer to the online help, or to the user's manual for your software: *VersaPro User's Guide* (GFK-1670) or *Using Control* (GFK-1295).

The following diagram identifies each field in the fault entry for the System Configuration Mismatch fault displayed above:

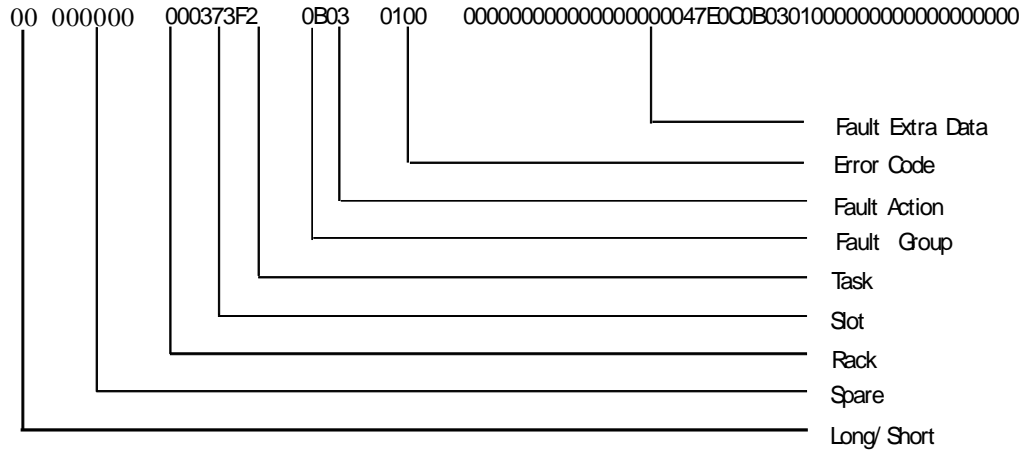

The System Configuration Mismatch fault entry is explained below. (All data is in hexadecimal.)

Field	Value	Description
Long/Short	00	This fault contains 8 bytes of fault extra data.
Rack	00	Main rack (rack 0).
Slot	03	Slot 3.
Task	44	
Fault Group	0B	System Configuration Mismatch fault.
Fault Action	03	FATAL fault.
Error Code	01	

The following paragraphs describe each field in the fault entry. Included are tables describing the range of values each field may have.

Long/Short Indicator

This byte indicates whether the fault contains 8 bytes or 24 bytes of fault extra data.

Type	Code	Fault Extra Data
Short	00	8 bytes
Long	01	24 bytes

Spare

These six bytes are pad bytes, used to make the PLC fault table entry exactly the same length as the I/O fault table entry.

Rack

The rack number ranges from 0 to 7. Zero is the main rack, containing the PLC. Racks 1 through 7 are expansion racks, connected to the PLC through an expansion cable.

Slot

The slot number ranges from 0 to 9. The PLC CPU always occupies slot 1 in the main rack (rack 0).

Task

The task number ranges from 0 to +65,535. Sometimes the task number gives additional information for PLC engineers; typically, the task can be ignored.

PLC Fault Group

Fault group is the highest classification of a fault. It identifies the general category of the fault.

Table B-1 lists the possible fault groups in the PLC fault table.

The last non-maskable fault group, *Additional PLC Fault Codes*, is declared for the handling of new fault conditions in the system without the PLC having to specifically know the alarm codes. All unrecognized PLC-type alarm codes belong to this group.

Table B-1. PLC Fault Groups

Group Number		Group Name	Fault Action
Decimal	Hexadecimal		
1	1	Loss of, or missing, rack.	Fatal
4	4	Loss of, or missing, option module.	Diagnostic
5	5	Addition of, or extra, rack.	Diagnostic
8	8	Addition of, or extra, option module.	Diagnostic
11	B	System configuration mismatch.	Fatal
12	C	System bus error.	Diagnostic
13	D	PLC CPU hardware failure.	Fatal
14	E	Non-fatal module hardware failure.	Diagnostic
16	10	Option module software failure.	Diagnostic
17	11	Program block checksum failure.	Fatal
18	12	Low battery signal.	Diagnostic
19	13	Constant sweep time exceeded.	Diagnostic
20	14	PLC system fault table full.	Diagnostic
21	15	I/O fault table full.	Diagnostic
22	16	User Application fault.	Diagnostic
–	–	Additional PLC fault codes.	As specified
128	80	System bus failure.	Fatal
129	81	No user's program on power-up.	Informational
130	82	Corrupted user RAM detected.	Fatal
132	84	Password access failure.	Informational
135	87	PLC CPU software failure.	Fatal
137	89	PLC sequence-store failure.	Fatal

Fault Action

Each fault may have one of three actions associated with it. These fault actions are fixed on the Series 90-30 PLC and cannot be changed by the user.

Table B-2. PLC Fault Actions

Fault Action	Action Taken by CPU	Code
Informational	Log fault in fault table.	1
Diagnostic	Log fault in fault table. Set fault references.	2
Fatal	Log fault in fault table. Set fault references. Go to STOP mode.	3

Error Code

The error code further describes the fault. Each fault group has its own set of error codes. Table B-3 shows error codes for the PLC Software Error Group (Group 87H).

Table B-3. Alarm Error Codes for PLC CPU Software Faults

Decimal	Hexadecimal	Name
20	14	Corrupted PLC Program Memory.
39	27	Corrupted PLC Program Memory.
82	52	Backplane Communications Failed.
90	5A	User Shut Down Requested.
All others		PLC CPU Internal System Error.

Table B-4 shows the error codes for all the other fault groups.

Table B-4. Alarm Error Codes for PLC Faults

Decimal	Hexadecimal	Name
<i>PLC Error Codes for Loss of Option Module Group (04)</i>		
44	2C	Option Module Soft Reset Failed
45	2D	Option Module Soft Reset Failed
79	4F	Loss of Daughterboard
255	FF	Option Module Communication Failed
<i>Error Codes for Reset of, Addition of, or Extra Option Module Group (08)</i>		
2	2	Module Restart Complete
4	4	Addition of Daughterboard
5	5	Reset of Daughterboard
	All others	Reset of, Addition of, or Extra Option Module
<i>Error Codes for System Configuration Mismatch Group (11)</i>		
8	8	Analog Expansion Mismatch
10	A	Unsupported Feature
23	17	Program exceeds memory limits
58	3A	Mismatch of Daughterboard
<i>Error Codes for System Bus Error Group (12)</i>		
	All others	System Bus Error
<i>Error Codes for PLC CPU Hardware Faults (13)</i>		
	All codes	PLC CPU Hardware Failure
<i>Error Codes for Option Module Software Failure Group (16)</i>		
1	1	Unsupported Board Type
2	2	COMREQ – mailbox full on outgoing message that starts the COMREQ
3	3	COMREQ – mailbox full on response
5	5	Backplane Communications with PLC; Lost Request
11	B	Resource (alloc, tbl ovrlw, etc.) error
13	D	User program error
401	191	Module Software Corrupted; Requesting Reload
<i>Error Codes for Program Block Checksum Group (17)</i>		
3	3	Program or program block checksum failure
<i>Error Codes for Low Battery Signal (18)</i>		
0	0	Failed battery on PLC CPU or other module
1	1	Low battery on PLC CPU or other module
<i>Error Codes for User Application Fault Group (22)</i>		
2	2	PLC Watchdog Timer Timed Out
5	5	COMREQ – WAIT mode not available for this command
6	6	COMREQ – Bad Task ID
7	7	Application Stack Overflow
<i>Error Codes for System Bus Failure Group (128)</i>		
1	1	Operating system
<i>Error Codes for Corrupted User RAM on Powerup Group (130)</i>		
1	1	Corrupted User RAM on Power-up
2	2	Illegal Boolean Opcode Detected
3	3	PLC_ISCP_PC_OVERFLOW
4	4	PRG_SYNTAX_ERR

Fault Extra Data

This field contains details of the fault entry. An example of what data may be present are:

**Corrupted
User RAM
Group:**

Four of the error codes in the System Configuration Mismatch group supply fault extra data:

Table B-5. PLC Fault Data - Illegal Boolean Opcode Detected

Fault Extra Data	Model Number Mismatch
[0]	ISCP Fault Register Contents
[1]	Bad OPCODE
[2,3]	ISCP Program Counter
[4,5]	Function Number

For a RAM failure in the PLC CPU (one of the faults reported as a PLC CPU hardware failure), the address of the failure is stored in the first four bytes of the field.

**PLC CPU
Hardware
Failure (RAM
Failure):**

PLC Fault Time Stamp

The six-byte time stamp is the value of the system clock when the fault was recorded by the PLC CPU. (Values are coded in BCD format.)

Table B-6. PLC Fault Time Stamp

Byte Number	Description
1	Seconds
2	Minutes
3	Hours
4	Day of the month
5	Month
6	Year

I/O Fault Table

The following diagram identifies the hexadecimal information displayed in each field in the fault entry.

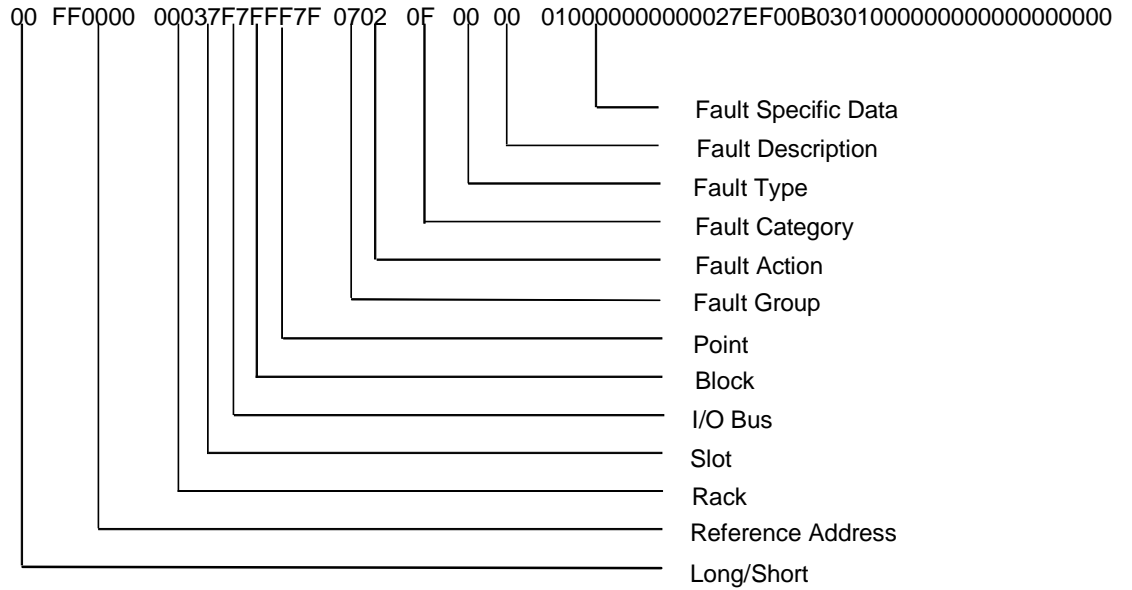

The following paragraphs describe each field in the I/O fault table. Included are tables describing the range of values each field may have.

Long/Short Indicator

This byte indicates whether the fault contains 5 bytes or 21 bytes of fault specific data.

Table B-7. I/O Fault Table Format Indicator Byte

Type	Code	Fault Specific Data
Short	02	5 bytes
Long	03	21 bytes

Reference Address

Reference address is a three-byte address containing the I/O memory type and location (or offset) in that memory which corresponds to the point experiencing the fault. Or, when a Genius block fault or integral analog module fault occurs, the reference address refers to the first point on the block where the fault occurred.

Table B-8. I/O Reference Address

Byte	Description	Range
0	Memory Type	0 – FF
1–2	Offset	0 – 7FF

The memory type byte is one of the following values.

Table B-9. I/O Reference Address Memory Type

Name	Value (Hexadecimal)
Analog input	0A
Analog output	0C
Analog grouped	0D
Discrete input	10 or 46
Discrete output	12 or 48
Discrete grouped	1F

I/O Fault Address

The I/O fault address is a six-byte address containing rack, slot, bus, block, and point address of the I/O point which generated the fault. The point address is a word; all other addresses are one byte each. All five values may not be present in a fault.

When an I/O fault address does not contain all five addresses, a 7F hex appears in the address to indicate where the significance stops. For example, if 7F appears in the bus byte, then the fault is a module fault. Only rack and slot values are significant.

Rack

The rack number ranges from 0 to 7. Zero is the main rack, i.e., the one containing the PLC. Racks 1 through 7 are expansion racks.

Slot

The slot number ranges from 0 to 9. The PLC CPU always occupies slot 1 in the main rack (rack 0).

Point

Point ranges from 1 to 1024 (decimal). It tells which point on the block has the fault when the fault is a point-type fault.

I/O Fault Group

Fault group is the highest classification of a fault. It identifies the general category of the fault.

Table B-10 lists the possible fault groups in the I/O fault table. Group numbers less than 80 (Hex) are maskable faults.

The last non-maskable fault group, *Additional I/O Fault Codes*, is declared for the handling of new fault conditions in the system without the PLC having to specifically know the alarm codes. All unrecognized I/O-type alarm codes belong to this group.

Table B-10. I/O Fault Groups

Group Number	Group Name	Fault Action
3	Loss of, or missing, I/O module.	Diagnostic
7	Addition of, or extra, I/O module.	Diagnostic
9	IOC or I/O bus fault.	Diagnostic
A	I/O module fault.	Diagnostic
–	Additional I/O fault codes.	As specified

I/O Fault Action

The fault action specifies what action the PLC CPU should take when a fault occurs. Table B-11 lists possible fault actions.

Table B-11. I/O Fault Actions

Fault Action	Action Taken by CPU	Code
Informational	Log fault in fault table.	1
Diagnostic	Log fault in fault table. Set fault references.	2
Fatal	Log fault in fault table. Set fault references. Go to STOP mode.	3

I/O Fault Specific Data

An I/O fault table entry may contain up to 5 bytes of I/O fault specific data.

Symbolic Fault Specific Data

Table B-12 lists data that is required for block circuit configuration.

Table B-12. I/O Fault Specific Data

Decimal Number	Hex Code	Description
<i>Circuit Configuration</i>		
	1	Circuit is an input – tristate.
	2	Circuit is an input.
	3	Circuit is an output.

Fault Actions for Specific Faults

Forced/unforced circuit faults are reported as informational faults. All others are diagnostic or fatal.

The model number mismatch, I/O type mismatch and non-existent I/O module faults are reported in the PLC fault table under the System Configuration Mismatch group. They are not reported in the I/O fault table.

I/O Fault Time Stamp

The six-byte time stamp is the value of the system clock when the fault was recorded by the PLC CPU. Values are coded in BCD format.

Table B-13. I/O Fault Time Stamp

Byte Number	Description
1	Seconds
2	Minutes
3	Hours
4	Day of the month
5	Month
6	Year

There are a few considerations you need to understand when using floating-point numbers. The first section discusses these general considerations. Refer to page C-5 and following for instructions on entering and displaying floating-point numbers.

Note

Floating-point capabilities are *only* supported on the 35x and 36x series CPUs, Release 9 or later, and on all releases of CPU352.

Floating-Point Numbers

The programming software provides the ability to edit, display, store, and retrieve numbers with real values. Some functions operate on floating-point numbers. However, to use floating-point numbers with the programming software, you must have a 35x or 36x series CPU (see Note above). Floating-point numbers are represented in decimal scientific notation, with a display of six significant digits.

Note

In this manual, the terms “floating-point” and “real” are used interchangeably to describe the floating-point number display/entry feature of the programming software.

The following format is used. For numbers in the range 9999999 to .0001, the display has no exponent and up to six or seven significant digits. For example:

Entered	Displayed	Description
.000123456789	+0.0001234567	Ten digits, six or seven significant.
-12.345e-2	-.1234500	Seven digits, six or seven significant.
1234	+1234.000	Seven digits, six or seven significant.

Outside the range listed above, only six significant digits are displayed and the display has the form:

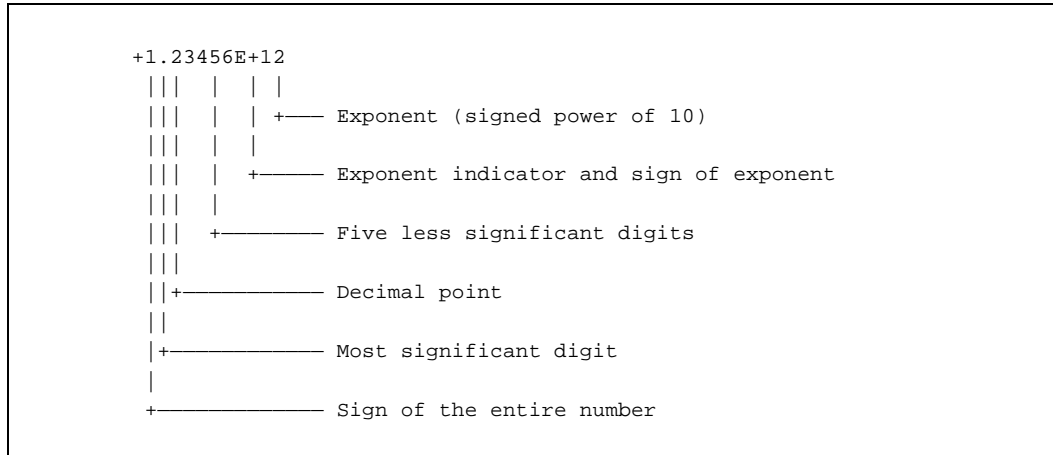

Internal Format of Floating-Point Numbers

Floating-point numbers are stored in single precision IEEE-standard format. This format requires 32 bits, which translates to two adjacent 16-bit PLC registers. The encoding of the bits is diagrammed below.

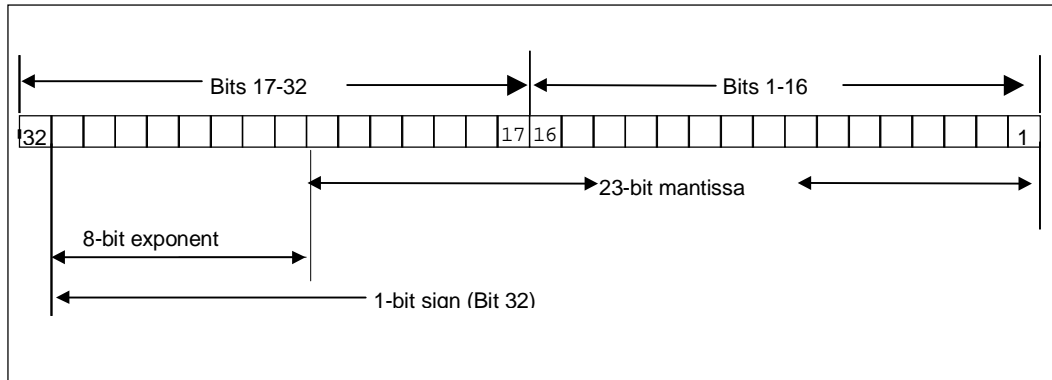

Register use by a single floating-point number is diagrammed below. In this diagram, if the floating-point number occupies registers R5 and R6, for example, R5 is the least significant register and R6 is the most significant register.

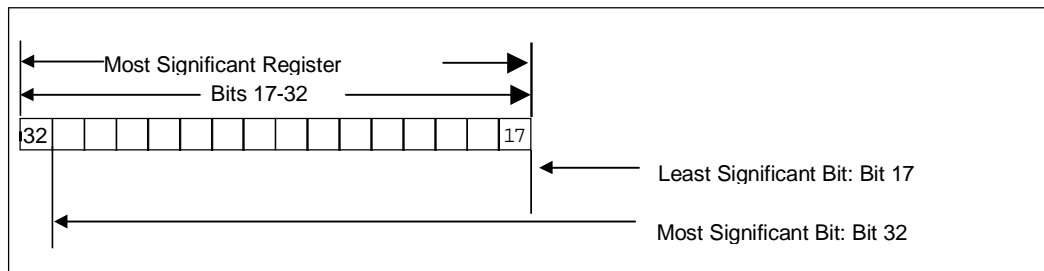
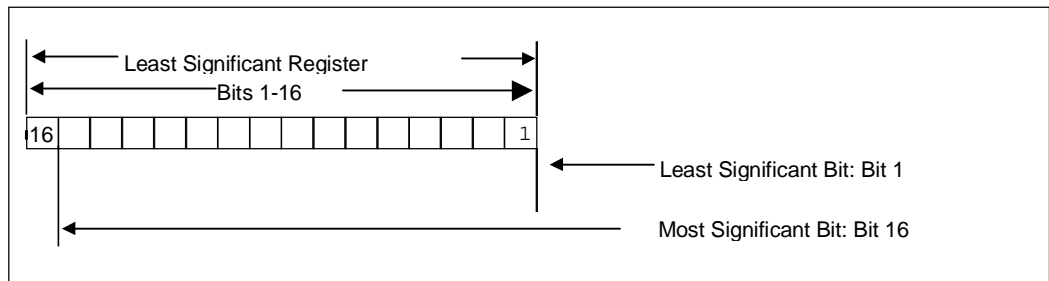

Values of Floating-Point Numbers

Use the following table to calculate the value of a floating-point number from the binary number stored in two registers.

Exponent (e)	Mantissa (f)	Value of Floating Point Number
255	Non-zero	Not a valid number (NaN).
255	0	$-1^s * \infty$
$0 < e < 255$	Any value	$-1^s * 2^{e-127} * 1.f$
0	Non-zero	$-1^s * 2^{-126} * 0.f$
0	0	0

f = the mantissa. The mantissa is a binary fraction.

e = the exponent. The exponent is an integer E such that $E+127$ is the power of 2 by which the mantissa must be multiplied to yield the floating-point value.

s = the sign bit.

* = the multiplication operator.

For example, consider the floating-point number 12.5. The IEEE floating-point binary representation of the number is:

01000001 01001000 00000000 00000000

or 41480000 hex. The most significant bit (the sign bit) is zero (s=0). The next eight most significant bits are 10000010, or 130 decimal (e=130).

The mantissa is stored as a decimal binary number with the decimal point preceding the most significant of the 23 bits. Thus, the most significant bit in the mantissa is a multiple of 2^{-1} , the next most significant bit is a multiple of 2^{-2} , and so on to the least significant bit, which is a multiple of 2^{-23} . The final 23 bits (the mantissa) are:

1001000 00000000 00000000

The value of the mantissa, then, is .5625 (that is, $2^{-1} + 2^{-4}$).

Since $e > 0$ and $e < 255$, we use the third formula in the table above:

$$\begin{aligned}
 \text{number} &= -1^s * 2^{e-127} * 1.f \\
 &= -1^0 * 2^{130-127} * 1.5625 \\
 &= 1 * 2^3 * 1.5625 \\
 &= 8 * 1.5625 \\
 &= 12.5
 \end{aligned}$$

Thus, you can see that the above binary representation is correct.

The range of numbers that can be stored in this format is from $\pm 1.401298E-45$ to $\pm 3.402823E+38$ and the number zero.

Entering and Displaying Floating-Point Numbers

In the mantissa, up to six or seven significant digits of precision may be entered and stored; however, the programming software will display only the first six of these digits. The mantissa may be preceded by a positive or negative sign. If no sign is entered, the floating-point number is assumed to be positive.

If an exponent is entered, it must be preceded by the letter **E** or **e**, and the mantissa must contain a decimal point to avoid mistaking it for a hexadecimal number. The exponent may be preceded by a sign; but, if none is provided, it is assumed to be positive. If no exponent is entered, it is assumed to be zero. No spaces are allowed in a floating-point number.

To provide ease-of-use, several formats are accepted in both command-line and field data entry. These formats include an integer, a decimal number, or a decimal number followed by an exponent. These numbers are converted to a standard form for display once the user has entered the data and pressed the **Enter** key.

Examples of valid floating-point number entries and their normalized display are shown below.

Entered	Displayed
250	+250,0000
+4	+4.000000
-2383019	-2383019.
34.	+34.00000
-.0036209	-.003620900
12.E+9	+1.20000E+10
-.0004E-11	-4.00000E-15
731.0388	+731.0388
99.20003e-29	+9.92000E-28

Examples of invalid floating-point number entries are shown below.

Invalid Entry	Explanation
-433E23	Missing decimal point.
10e-19	Missing decimal point.
10.e19	The mantissa cannot contain spaces between digits or characters. This is accepted as 10.e0, and an error message is displayed.
4.1e19	The exponent cannot contain spaces between digits or characters. This is accepted as 4.1e0, and an error message is displayed.

Errors in Floating-Point Numbers and Operations

On a 352 CPU, overflow occurs when a number greater than 3.402823E+38 or less than -3.402823E+38 is generated by a REAL function. On all other 90-30 models that support floating point operations, the range is greater than 2^{16} or less than -2^{16} . When your number exceeds the range, the ok output of the function is set OFF; and the result is set to positive infinity (for a number greater than 3.402823E+38 on a 352 CPU or 2^{16} on all other models) or negative infinity (for a number less than -3.402823E+38 or -2^{16} on all other models). You can determine where this occurs by testing the sense of the ok output.

POS_INF = 7F800000h – IEEE positive infinity representation in hex.
 NEG_INF = FF800000h – IEEE negative infinity representation in hex.

Note

If you are using software floating point (all models capable of floating point operations except the 352 CPU), numbers are rounded to zero (0) at $\pm 1.175494E-38$.

If the infinities produced by overflow are used as operands to other REAL functions, they may cause an undefined result. This undefined result is referred to as a NaN (Not a Number). For example, the result of adding positive infinity to negative infinity is undefined. When the ADD_REAL function is invoked with positive infinity and negative infinity as its operands, it produces a NaN for its result.

On a 352 CPU, each REAL function capable of producing a NaN produces a specialized NaN which identifies the function:

NaN_SW = FFFFFFFFh – Software floating point NaN.
 NaN_ADD = 7F81FFFFh – Real addition error value in hex.
 NaN_SUB = 7F81FFFFh – Real subtraction error value in hex.
 NaN_MUL = 7F82FFFFh – Real multiplication error value in hex.
 NaN_DIV = 7F83FFFFh – Real division error value in hex.
 NaN_SQRT = 7F84FFFFh – Real square root error value in hex.
 NaN_LOG = 7F85FFFFh – Real logarithm error value in hex.
 NaN_POW0 = 7F86FFFFh – Real exponent error value in hex.
 NaN_SIN = 7F87FFFFh – Real sine error value in hex.
 NaN_COS = 7F88FFFFh – Real cosine error value in hex.
 NaN_TAN = 7F89FFFFh – Real tangent error value in hex.
 NaN_ASIN = 7F8AFFFFh – Real inverse sine error value in hex.
 NaN_ACOS = 7F8BFFFFh – Real inverse cosine error value in hex.
 NaN_BCD = 7F8CFFFFh – BCD-4 to real error.
 REAL_INDEF = FFC00000h – Real indefinite, divide 0 by 0 error.

All other CPUs that support floating point operations produce one NaN output: FFFF FFFF.

When a NaN result is fed into another function, it passes through to the result. For example, if a NaN_ADD is the first operand to the SUB_REAL function, the result of the SUB_REAL is NaN_ADD. If both operands to a function are NaNs, the first operand will pass through. Because of this feature of propagating NaNs through functions, you can identify the function where the NaN originated.

Note

For NaN, the ok output is OFF (not energized).

The following table explains when power is or is not passed when dealing with numbers viewed as or equal to infinity for binary operations such as Add, Multiply, etc. As shown previously, outputs that exceed the positive or negative limits are viewed as POS_INF or NEG_INF respectively.

Table C-1. General Case of Power Flow for Floating-Point Operations

Operation	Input 1	Input 2	Output	Power Flow
All	Number	Number	Positive or Negative Infinity	No
All Except Division	Infinity	Number	Infinity	Yes
All	Number	Infinity	Infinity	Yes
Division	Infinity	Number	Infinity	No
All	Number	Number	NaN	No

This appendix describes how to set up 32-bit modem communications with your PLC using the Windows programming software and the Communications Configuration Utility (CCU). If you are unable to use the built-in communications utility, HyperTerminal software can be used as an alternate means of establishing modem communications.

Modem Configuration and Cabling

Refer to the setup documents (cabling, AT commands, general setup) for your modem at:

<http://www.gefanuc.com/support/plc/modems.htm>

or on our FaxLink system (804-978-5824):

FaxLink Document	Modem
2302	Hayes Optima
2303	Practical Peripherals
2304	Motorola V3225 4-wire leased line
2305	Data-Linc dialup/leased line
2307	MultiTech 1932ZDX
2308	Boca Modem V.34 28.8, V.32 14.4 Model M14EW
2310	USRobotics 56K

PLC CPU Configuration

1. In VersaPro or Control open the Hardware Configuration (HWC) utility. If a CPU has not been configured, choose the desired PLC CPU type.
2. In the Parameters dialog box for the CPU, enter the desired baud rate (9600 typically), no parity, 1 stop bit, and a modem turnaround of 1 (if necessary.)

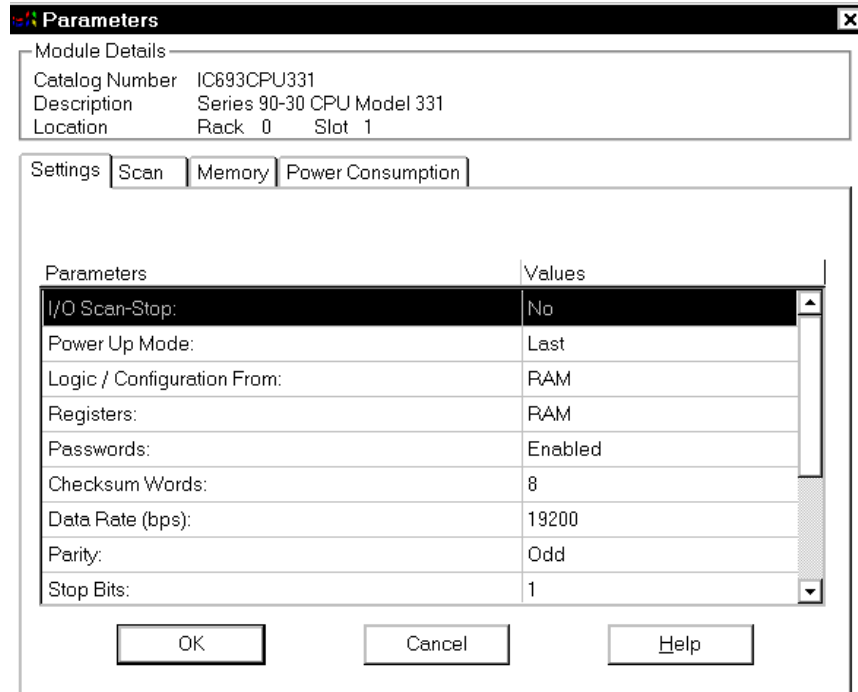

3. Save the configuration of the CPU and download it to the PLC.

Installing the Modem into Windows

1. In the Start menu, choose Settings, Control Panel, and Modems icon. In the Modems Properties dialog box, click the Add button and install a standard modem (typically 9600).

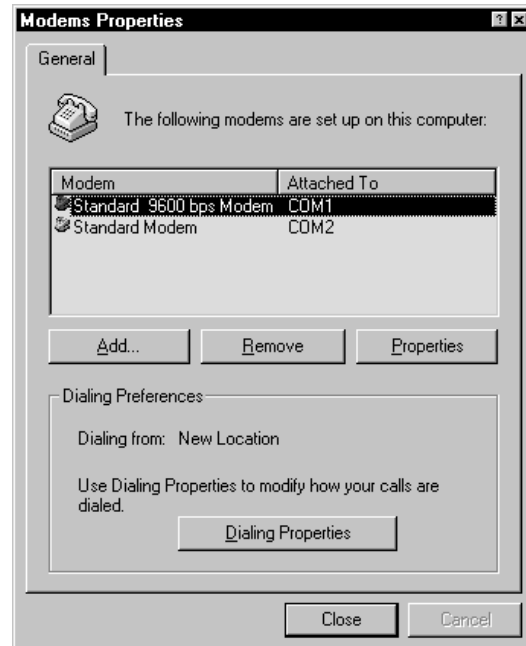

2. With the standard modem selected, click the Properties button. Under the maximum speed for that modem, choose 9600 (or other desired baud rate) if it is not already selected.
3. On the Connection tab, the Data bits should be 8, Parity should be none, and Stop bits should be 1.

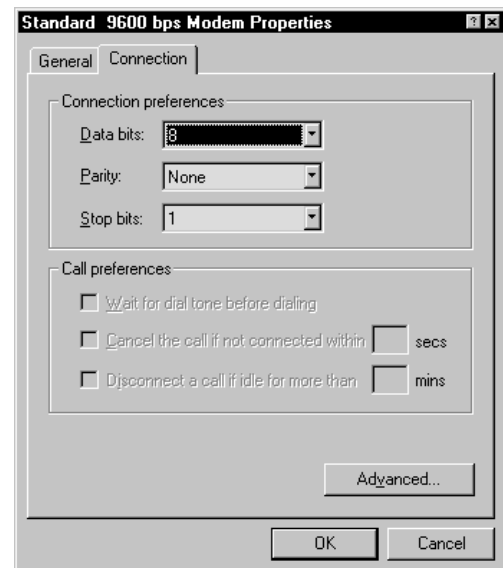

- Click the Advanced... button, and deselect the Flow Control checkbox.

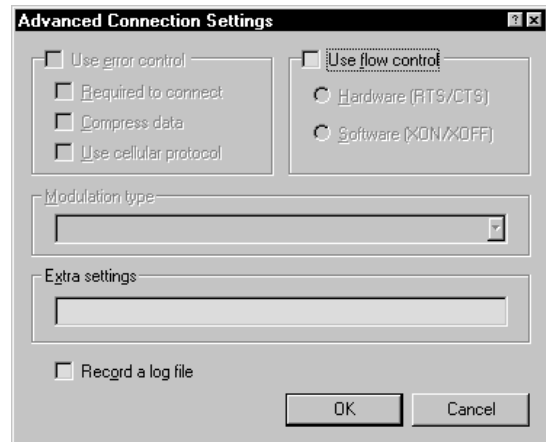

- Click OK until you have closed the Modem Properties dialog box.

Setting Up the Communications Configuration Utility (CCU)

- In VersaPro, in the Tools menu, and Control, under the COMM menu selects Communications Setup. Enter your password (default is **netutil**). Once in the CCU, select the Modems tab. Click New to add a new modem to the list.

Give the modem a name and enter the area code and phone number. Click OK to accept the modem.

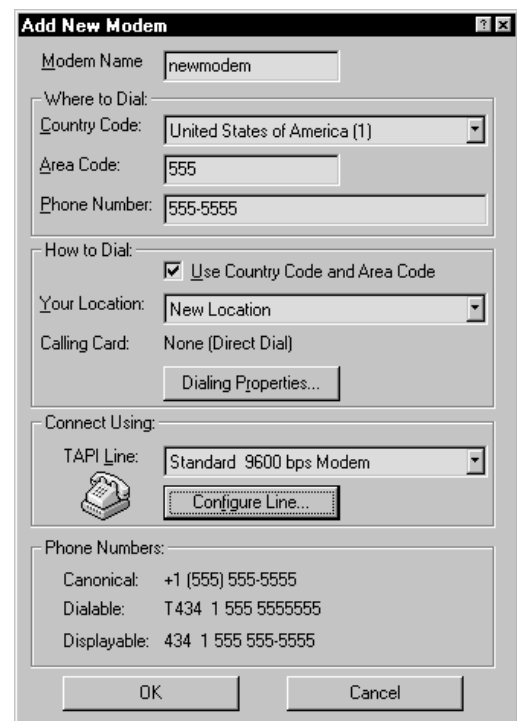

Note

Although the Configure Line button opens a modem properties dialog box, changes to parameters in this box *are not saved*. Use the Windows Control Panel to configure the modem.

- In the CCU, click on the Ports tab. Click New to add a new port to the list.

Add New Port

Port Selection

Name:

Type:

Physical Port:

SNP Timers in milliseconds

SNP_T1	<input type="text" value="10"/>
SNP_T2	<input type="text" value="3000"/>
SNP_T3	<input type="text" value="10000"/>
SNP_T3P	<input type="text" value="10100"/>
SNP_T3PP	<input type="text" value="65000"/>
SNP_T4	<input type="text" value="600"/>
SNP_T5	<input type="text" value="10000"/>
SNP_T5P	<input type="text" value="10100"/>
SNP_T5PP	<input type="text" value="10250"/>

Port Settings

Stopbits:

Parity:

Baudrate:

Modem Turnaround Time (10ms):

Associated Modem:

Timeouts in milliseconds

Connect Timeout:

Request Timeout:

Port supports Multisession

Multisession:

Buttons: OK, Cancel, Default, Help, Advanced >>

Enter the name of the port.

Next to Type, select SNP_SERIAL.

Next to Physical Port, select the desired COM port for the modem on your computer.

Set the Port Settings to be equal with those that were configured for the PLC CPU.

Select the Associated Modem that was created in step 1.

Click the Advanced button.

Next to Connect Timeout, enter a value (in milliseconds) of approximately 40000 (40 seconds). This time may be longer or shorter depending on how long it takes for the modem to establish communications.

Click OK to accept the port.

3. In the CCU, click on the Devices tab. Click New to add a new device to the list.

Under Device Name, type in the desired name for the device.

Next to Device Model, select from the list the type of CPU to communicate with.

Next to Default Port, select from the list the port that was created in step 2.

Next to Associated Modem, select the modem that was created in step 1 from the list (If the port and/or the modem do not appear in the list, they need to be created and saved).

Click OK to accept the device.

4. Click OK in the CCU to accept the configuration changes.

Connecting to the PLC

1. In Control software, under the COMM menu, select Connect. In VersaPro, go to the PLC menu and select Connect.

2. If not already selected, select the Device and Port that are configured for the modem. Click Connect to initiate communications with the PLC. The modem will dial and communications will be initialized.

Using the HyperTerminal Utility to Establish Connection

If the modem will not dial or connect using the built-in communications, HyperTerminal can be used as a backup. When using HyperTerminal, the modem functions (dialing, hanging up) are executed independently of the PLC programming software. Once the modems are connected to each other, the PLC programming software will communicate as if it were connected directly to the PLC.

Note

This approach *may not work* for PCMCIA modems.

Modem configuration can be accomplished with HyperTerminal by entering the “AT” commands specified by the FaxLink documents listed on page D-1. Some typical settings necessary for SNP to operate across a modem connection are:

- Flow control – disabled
- Error correction – disabled
- Data compression – disabled
- Baud rate – only at the desired baud rate
- Break signal – sent intact (only for pre-Break-Free CPUs)
- DTR signal – ignored
- Autoanswer for remote modem – selected

1. To start HyperTerminal, go to the Start menu and select Programs, Accessories, and HyperTerminal. (In Windows 98, HyperTerminal is under Accessories, Communications...) In HyperTerminal, enter a name for the connection. Naming and saving the connection makes it easier to re-connect in the future.
2. To open the Properties dialog box, go to File, Properties. Next to Connect Using, choose the comm port that the modem is connected (or mapped) to.
3. Click the Configure button to configure the communications parameters. Set the baud rate to 9600 (or other desired baud rate), data bits to 8, parity to none, stop bits to 1, and flow control to none. Click OK to accept the parameters.

Modems autobaud to the settings of the DTE when in command mode. This means that any port settings will work to configure the modem and dial it. However, when the modem is in data mode (connected to another modem), the modem may not respond to the escape sequence unless it is sent at the same baud rate at which the modem is communicating.

4. In HyperTerminal, test the connection to the modem by typing AT and pressing ENTER. The modem should respond with “OK”. To dial the modem, type ATDT# (where # is the phone number of the remote modem) and wait for the connection response (ex. CONNECT 9600).
5. Set up the PLC programmer to communicate at the desired port settings, but assume a standard serial port connection, not a modem connection, using the desired port setup parameters. The port setup in the CCU will not have an associated modem, but will have a modem turnaround time.

6. To hang up, first disconnect the PLC programmer connection (this will free up the comm port for use with HyperTerminal). Then connect to the modem with HyperTerminal. While connected, wait at least 1 second, then type three plus signs (+++). One second later, the modem should respond with an "OK". Next, enter ATH, the hang-up command. The modem should respond "OK" again.

Remember that the HyperTerminal connection must be set to the same baud rate that the modem is currently communicating at. If not, the escape sequence may not be recognized.

Other Issues

Because of the dynamic nature of the computer/communications industry and limited resources for testing modems, a situation may arise where a recommended modem can not be found. If this is the situation, there are a few steps that can be taken to see if an alternate modem will work in your system.

Chipset

The first thing to look at is the chipset that the modem uses. This can be obtained from the modem manufacturer, their web site, or occasionally through the computer manufacturer. The chipset dictates the AT commands used to configure the modem. The AT command reference will be available from the chipset manufacturer (typically Rockwell, Lucent, USRobotics, Hayes -- R.I.P.)

Break

Applies to the following CPU models: 350 and higher, before revision 9.00

341, 331, 323, 313, and 311 before revision 8.20

For those CPUs that require the break to be passed, the modem needs to send the break intact without affecting the data being sent. This mode is sometimes called non-destructive, expedited. A destructive break will clear all data in the buffers of the modem. Typical parameters to look for are the 'S82' register (for most chipsets) and the '&Y' command (for USR).

Flow Control, Data Compression, and Error Correction

These should be disabled. Flow control must be disabled because SNP uses the CTS signal for cable detection, not flow control. Data compression and error correction must be disabled because they cannot be used without flow control. Error correction modifies the character timing, but with a large enough modem buffer, may be able to be used without flow control.

Other Considerations

- PCMCIA modems sometimes operate differently than external modems. One major difference is that some PCMCIA drivers will remove power from the modem card when the port is deactivated. This means that dialing with HyperTerminal will not work. You must use the modem connect procedure within the programming software in order to keep the com port handle active.
- The baud rate is a critical setting for reliable communications. 19200 baud is the current maximum rate for GE Fanuc PLCs, but the distance between modems and line quality will

dictate what baud rate is acceptable. SNP does not use hardware flow control and all data quality features of the modems must be disabled. Therefore we are relying on an 8-bit checksum to catch transmission errors, meaning 1 out of every 256 errors will be detected. Running the modem over low-quality analog phone lines with high data rates will increase the chances of transmission errors. It is a good idea to find the optimum baud rate by experimenting with the actual line quality and connection rate before fully implementing a system.

- Forcing the modems to a single baud rate is desirable. Because the PLC serial port can only be configured to one rate, forcing the PLC modem to its baud rate ensures that the modems will not choose a different negotiating speed.
- Most modems will not pass parity, and specifically state that they will not pass parity settings.
- The modem turnaround time in the PLC and programmer delays the time from when the device receives transmission to when it responds. You need to have a value of 1 (10ms) or greater in the PLC and programmer.

3

35x and 36x series CPUs: key switch, 2-13

A

ADD_IOM, 2-24
 ADD_SIO, 2-24
 Addition of I/O module, 3-18
 Alarm, 3-2
 Alarm error codes, B-5
 Alarm processor, 3-2
 ANY_FLT, 2-25
 APL_FLT, 2-24
 Appendices
 A - Instruction timing, A-1
 B - Interpreting fault tables, B-1
 C - Using floating-point numbers, C-1
 D - Setting up a modem, D-1
 Application fault, 3-12
 Application program logic scan, 2-8

B

BAD_PWD, 2-24
 BAD_RAM, 2-24
 Battery signal, low, 3-11
 BCD Format
 for SER function block trigger timestamp, A-11
 BCD-4, 2-21
 BIT, 2-21
 Block locking feature, 2-35
 EDITLOCK, 2-35
 permanently locking a subroutine, 2-35
 VIEWLOCK, 2-35
 Boolean execution times, A-12
 BYTE, 2-21

C

CCU
 setting up, D-4
 CFG_MM, 2-24
 Checksum calculation, 2-8
 Checksum failure, program block, 3-11
 Clocks, 2-32
 elapsed time clock, 2-32
 time-of-day clock, 2-32
 COMMREQ
 error code, description, and correction, 3-11
 Communication request function
 error code, description, and correction, 3-11
 Communication window modes, 2-13
 Communications failure during store, 3-16

Communications with the PLC, 2-11
 Configuration mismatch, system, 3-10
 Connecting to the PLC, D-6
 Constant sweep time exceeded, 3-12
 Constant sweep time mode, 2-12, 2-33
 Constant sweep timer, 2-33
 Corrupted memory, 3-8
 Corrupted user program on power-up, 3-13
 CPU sweep, 2-2

D

Data retentiveness, 2-20
 Data types, 2-21
 BCD-4, 2-21
 BIT, 2-21
 BYTE, 2-21
 DINT, 2-21
 INT, 2-21
 REAL, 2-21
 WORD, 2-21
 Defaults conditions for Model 30 output
 modules, 2-39
 Diagnostic data, 2-40
 Diagnostic faults, 3-4
 addition of I/O module, 3-18
 application fault, 3-12
 constant sweep time exceeded, 3-12
 loss of I/O module, 3-17
 loss of, or missing, option module, 3-9
 low battery signal, 3-11
 reset of, addition of, or extra, option module, 3-9
 DINT, 2-21
 Discrete references, 2-19
 discrete inputs, 2-19
 discrete internal, 2-19
 discrete outputs, 2-19
 discrete temporary, 2-19
 global data, 2-20
 system references, 3-5
 system status, 2-20, 2-22
 Double precision signed integer, 2-21
 DSM communications with the PLC, 2-11
 DSM314
 I/O scan time contributions, 2-5
 local logic programs, 2-40
 DSM314 and DSM302 communications with
 PLC, 2-11

E

EDITLOCK, 2-35
 Elapsed time clock, 2-32
 Error codes, B-5
 Ethernet Global Data, 2-40
 External I/O failures, 3-2

F

- Fatal faults, 3-4
 - communications failure during store, 3-16
 - corrupted user program on power-up, 3-13
 - option module software failure, 3-11
 - PLC CPU system software failure, 3-14
 - program block checksum failure, 3-11
 - system configuration mismatch, 3-10
- Fault action, 3-4, 3-9
 - diagnostic faults, 3-4
 - fatal faults, 3-4
 - I/O fault action, B-10
 - informational faults, 3-4
 - PLC fault action, B-4
- Fault category, 3-17
- Fault description, 3-17
- Fault effects, additional, 3-5
- Fault explanation and correction
 - I/O fault group, B-10
 - interpreting a fault, B-1
 - PLC fault group, B-3
- Fault explanations and correction, 3-1
 - accessing additional fault information, 3-7
 - addition of I/O module, 3-18
 - application fault, 3-12
 - communications failure during store, 3-16
 - constant sweep time exceeded, 3-12
 - corrupted user program on power-up, 3-13
 - fault category, 3-17
 - fault description, 3-17
 - fault handling, 3-2
 - fault type, 3-17
 - I/O fault table, 3-6
 - I/O fault table explanations, 3-17
 - loss of, or missing, option module, 3-9
 - low battery signal, 3-11
 - no user program present, 3-12
 - non-configurable faults, 3-9
 - option module software failure, 3-11
 - password access failure, 3-13
 - PLC CPU system software failure, 3-14
 - PLC fault table, 3-6
 - PLC fault table explanations, 3-8
 - program block checksum failure, 3-11
 - reset of, addition of, or extra, option module, 3-9
 - system configuration mismatch, 3-10
- Fault group, B-3, B-10
- Fault handling, 3-2
 - alarm processor, 3-2
 - fault action, 3-4
- Fault references, 3-5
 - definitions of, 3-5
- Fault type, 3-17
- Faults, 3-2
 - accessing additional fault information, 3-7
 - actions, 3-9
 - addition of I/O module, 3-18
 - additional fault effects, 3-5
 - application fault, 3-12
 - classes of faults, 3-2
 - communications failure during store, 3-16
 - constant sweep time exceeded, 3-12
 - corrupted user program on power-up, 3-13
 - error codes, B-5
 - explanations and correction, 3-1
 - external I/O failures, 3-2
 - fault action, 3-4
 - I/O fault action, B-10
 - I/O fault group, B-10
 - I/O fault table, 3-3, 3-6
 - I/O fault table explanations, 3-17
 - internal failures, 3-2
 - interpreting a fault, B-1
 - loss of I/O module, 3-17
 - loss of, or missing, option module, 3-9
 - low battery signal, 3-11
 - no user program present, 3-12
 - operational failures, 3-2
 - option module software failure, 3-11
 - password access failure, 3-13
 - PLC CPU system software failure, 3-14
 - PLC fault action, B-4
 - PLC fault group, B-3
 - PLC fault table, 3-3, 3-6
 - PLC fault table explanations, 3-8
 - program block checksum failure, 3-11
 - references, 3-5
 - reset of, addition of, or extra, option module, 3-9
 - system configuration mismatch, 3-10
 - system reaction to faults, 3-3
- Faults, interpreting, B-1
- Flash protection on 35x and 36x series CPUs, 2-13
- Floating-point numbers, C-1
 - entering and displaying floating-point numbers, C-5
 - errors in floating-point numbers and operations, C-6
 - internal format of floating-point numbers, C-3
 - values of floating-point numbers, C-4
- Function block parameters, 2-27
- Function block structure, 2-25
 - format of program function blocks, 2-26
 - format of relays, 2-25
 - function block parameters, 2-27
 - power flow, 2-28

G

- Genius Global Data, 2-40
- Global data, 2-40
- Global data references, 2-20

H

Housekeeping, 2-7
 HRD_CPU, 2-24
 HRD_FLT, 2-25
 HRD_SIO, 2-24
 HyperTerminal, D-7

I

I/O data formats, 2-39
 I/O fault table, 3-3, 3-6, B-8
 explanations, 3-17
 fault action, B-10
 fault actions for specific faults, B-11
 fault address, B-9
 fault group, B-10
 fault specific data, B-11
 fault time stamp, B-11
 interpreting a fault, B-1
 long/short indicator, B-9
 point, B-10
 rack, B-10
 reference address, B-9
 slot, B-10
 symbolic fault specific data, B-11
 I/O structure, Series 90-30 PLC, 2-36
 I/O system, Series 90-30 PLC, 2-36
 I/O system, Series 90-20 PLC, 2-36
 I/O system, Series 90-30 PLC
 default conditions for Model 30 output modules,
 2-39
 diagnostic data, 2-40
 global data, 2-40
 I/O data formats, 2-39
 model 30 I/O modules, 2-37
 Informational faults, 3-4
 no user program present, 3-12
 password access failure, 3-13
 Input references, discrete, 2-19
 Input register references, analog, 2-19
 Input scan, 2-7
 Instruction timing, A-1
 high performance models, A-6
 SER, A-10
 standard models, A-2
 INT, 2-21
 Internal failures, 3-2
 Internal references, discrete, 2-19
 Interpreting fault tables, B-1
 IO_FLT, 2-25
 IO_PRES, 2-25

K

Key switch on 35x and 36x series CPUs, 2-13

L

Levels, privilege, 2-34
 change requests, 2-34
 Local logic programs, 2-40
 Locking/unlocking subroutines, 2-35
 Logic program checksum calculation, 2-8
 Logic solution, 2-8
 LOS_IOM, 2-24
 LOS_SIO, 2-24
 Loss of I/O module, 3-17
 Loss of, or missing, option module, 3-9
 Low battery signal, 3-11
 LOW_BAT, 2-24

M

Maintenance, 3-1
 Manuals
 for I/O modules, 2-37
 Memory, corrupted, 3-8
 Model 30 I/O modules, 2-37
 Modems
 configuration and cabling, D-1
 connecting to the PLC, D-6
 installing in Windows, D-3
 PLC CPU configuration, D-2
 using HyperTerminal to establish connection,
 D-7

N

No user program present, 3-12

O

Operation of system, 2-1
 Operational failures, 3-2
 Option module software failure, 3-11
 Output references, discrete, 2-19
 Output register references, analog, 2-19
 Output scan, 2-8
 OV_SWP, 2-24
 Overrides, 2-20

P

Password access failure, 3-13
 Passwords, 2-34
 PB_SUM, 2-24
 PCM communications with the PLC, 2-11
 Periodic subroutines, 2-18
 PLC CPU configuration
 for modem communications, D-2

- PLC CPU system software failure, 3-14
 - PLC fault table, 3-3, 3-6, B-2
 - error codes, B-5
 - explanations, 3-8
 - fault action, B-4
 - fault group, B-3
 - fault time stamp, B-7
 - interpreting a fault, B-1
 - long/short indicator, B-2
 - rack, B-3
 - slot, B-3
 - spare, B-3
 - task, B-3
 - PLC sweep, 2-2
 - application program logic scan, 2-8
 - configured constant sweep time mode, 2-12
 - constant sweep time mode, 2-12, 2-33
 - DSM communications with the PLC, 2-11
 - housekeeping, 2-7
 - input scan, 2-7
 - logic program checksum calculation, 2-8
 - logic solution, 2-8
 - output scan, 2-8
 - PCM communications with the PLC, 2-11
 - programmer communications window, 2-9
 - scan time contributions for 35x and 36x series, 2-5, 2-6
 - standard program sweep mode, 2-2
 - standard program sweep variations, 2-12
 - STOP mode, 2-12
 - sweep time calculation, 2-7
 - sweep time contribution, 2-4
 - PLC system operation, 2-1
 - POSIX Format
 - for SER function block trigger timestamp, A-11
 - Power flow, 2-28
 - Power-down, 2-31
 - Power-up, 2-29
 - Power-up and power-down sequences, 2-29
 - power-down, 2-31
 - power-up, 2-29
 - Privilege level change requests, 2-34
 - Privilege levels, 2-34
 - change requests, 2-34
 - Program block
 - how blocks are called, 2-17
 - how C blocks are called, 2-17
 - how subroutines are called, 2-17
 - nested calls, 2-17
 - Program block checksum failure, 3-11
 - Program organization and user data
 - floating-point numbers, C-1
 - Program organization and user references/data, 2-15
 - data types, 2-21
 - function block structure, 2-25
 - retentiveness of data, 2-20
 - system status, 2-22
 - transitions and overrides, 2-20
 - user references, 2-19
 - Program structure
 - how blocks are called, 2-17
 - how C blocks are called, 2-17
 - how subroutines are called, 2-17
 - Program sweep, standard, 2-2
 - Programmer communications window, 2-9
 - Programs, local logic, 2-40
- ## R
- REAL
 - Data type structure, 2-21
 - Using floating-point numbers, C-1
 - Using Real numbers, C-1
 - Reboot after fatal fault, 3-4
 - references, 2-19
 - Register Reference
 - system registers, 2-19
 - Register references, 2-19
 - analog inputs, 2-19
 - analog outputs, 2-19
 - Reset of, addition of, or extra, option module, 3-9
 - Retentiveness of data, 2-20
- ## S
- Scan time contributions for 35x and 36x series CPUs, 2-5, 2-6
 - Scan, input, 2-7
 - Scan, output, 2-8
 - Security, system, 2-34
 - locking/unlocking subroutines, 2-35
 - passwords, 2-34
 - privilege level change requests, 2-34
 - privilege levels, 2-34
 - Series 90-20 PLC I/O system, 2-36
 - Series 90-30 PLC I/O system, 2-36
 - default conditions for Model 30 output modules, 2-39
 - diagnostic data, 2-40
 - global data, 2-40
 - I/O data formats, 2-39
 - I/O structure, 2-36
 - model 30 I/O modules, 2-37
 - Setting up a modem, D-1
 - SFT_CPU, 2-24
 - SFT_FLT, 2-25
 - SFT_SIO, 2-24
 - Signed integer, 2-21
 - SNPX_RD, 2-22
 - SNPX_WT, 2-22
 - SNPXACT, 2-22
 - Software failure, option module, 3-11
 - Standard program sweep mode, 2-2

- Standard program sweep variations, 2-12
 - Status references, system, 2-20, 2-22
 - STOP mode, 2-12
 - STOR_ER, 2-24
 - Subroutine blocks
 - examples of, 2-16
 - nested calls, 2-17
 - Subroutines, locking/unlocking, 2-35
 - Sweep time calculation, 2-7
 - Sweep, PLC, 2-2
 - application program logic scan, 2-8
 - constant sweep time mode, 2-12, 2-33
 - DSM communications with the PLC, 2-11
 - housekeeping, 2-7
 - input scan, 2-7
 - logic program checksum calculation, 2-8
 - logic solution, 2-8
 - output scan, 2-8
 - PCM communications with the PLC, 2-11
 - programmer communications window, 2-9
 - scan time contributions for 35x and 36x series CPUs, 2-5, 2-6
 - standard program sweep mode, 2-2
 - standard program sweep variations, 2-12
 - STOP mode, 2-12
 - sweep time calculation, 2-7
 - sweep time contribution, 2-4
 - SY_FLT, 2-25
 - SY_PRES, 2-25
 - System configuration mismatch, 3-10
 - System operation, 2-1
 - clocks and timers, 2-32
 - PLC sweep summary, 2-2
 - power-up and power-down sequences, 2-29
 - program organization and user references/data, 2-15
 - Series 90-20 PLC I/O system, 2-36
 - Series 90-30 PLC I/O system, 2-36
 - system security, 2-34
 - System references, 3-5
 - System register references, 2-19
 - System status references, 2-20, 2-22
 - ADD_IOM, 2-24
 - ADD_SIO, 2-24
 - ANY_FLT, 2-25
 - APL_FLT, 2-24
 - BAD_PWD, 2-24
 - BAD_RAM, 2-24
 - CFG_MM, 2-24
 - HRD_CPU, 2-24
 - HRD_FLT, 2-25
 - HRD_SIO, 2-24
 - IO_FLT, 2-25
 - IO_PRES, 2-25
 - LOS_IOM, 2-24
 - LOS_SIO, 2-24
 - LOW_BAT, 2-24
 - OV_SWP, 2-24
 - PB_SUM, 2-24
 - SFT_CPU, 2-24
 - SFT_FLT, 2-25
 - SFT_SIO, 2-24
 - SNPX_RD, 2-22
 - SNPX_WT, 2-22
 - SNPXA CT, 2-22
 - STOR_ER, 2-24
 - SY_FLT, 2-25
 - SY_PRES, 2-25
- ## T
- Temporary references, discrete, 2-19
 - Time-of-day clock, 2-32
 - Timers, 2-32
 - constant sweep timer, 2-33
 - time-tick contacts, 2-33
 - Watchdog timer, 2-33
 - Time-tick contacts, 2-33
 - Timing, instruction, A-1
 - high performance models, A-6
 - SER, A-10
 - standard models, A-2
 - Transitions, 2-20
 - Troubleshooting, 3-1
 - accessing additional fault information, 3-7
 - I/O fault table, 3-6
 - I/O fault table explanations, 3-17
 - interpreting a fault, B-1
 - non-configurable faults, 3-9
 - PLC fault table, 3-6
 - PLC fault table explanations, 3-8
- ## U
- User references, 2-19
 - analog inputs, 2-19
 - analog outputs, 2-19
 - discrete inputs, 2-19
 - discrete internal, 2-19
 - discrete outputs, 2-19
 - discrete references, 2-19
 - discrete temporary, 2-19
 - global data, 2-20
 - register references, 2-19
 - system references, 3-5
 - system registers, 2-19
 - system status, 2-20, 2-22
- ## V
- VIEWLOCK, 2-35
- ## W
- Watchdog timer, 2-33
 - Window
 - programmer communications window, 2-9
 - WORD, 2-21