

# GFK-0868

[Buy GE Fanuc PLC Series 90-70 NOW!](#)

## GE Fanuc Manual Series 90-70

MMS-Ethernet Communications

1-800-360-6802

[sales@pdfsupply.com](mailto:sales@pdfsupply.com)



# *GE Fanuc Automation*

---

*Programmable Control Products*

## *MMS-Ether net Communications for the Series 90<sup>TM</sup>-70 PLC*

*User's Manual*

*GFK0868*

*May 1994*

## *Warnings, Cautions, and Notes as Used in this Publication*

### **Warning**

Warning notices are used in this publication to emphasize that hazardous voltages, currents, temperatures, or other conditions that could cause personal injury exist in this equipment or may be associated with its use.

In situations where inattention could cause either personal injury or damage to equipment, a Warning notice is used.

### **Caution**

Caution notices are used where equipment might be damaged if care is not taken.

### **Note**

Notes merely call attention to information that is especially significant to understanding and operating the equipment.

This document is based on information available at the time of its publication. While efforts have been made to be accurate, the information contained herein does not purport to cover all details or variations in hardware or software, nor to provide for every possible contingency in connection with installation, operation, or maintenance. Features may be described herein which are not present in all hardware and software systems. GE Fanuc Automation assumes no obligation of notice to holders of this document with respect to changes subsequently made.

GE Fanuc Automation makes no representation or warranty, expressed, implied, or statutory with respect to, and assumes no responsibility for the accuracy, completeness, sufficiency, or usefulness of the information contained herein. No warranties of merchantability or fitness for purpose shall apply.

The following are trademarks of GE Fanuc Automation North America, Inc.

Alam Master	CIMSTAR	Helpmate	PROMACRO	Series Six
CIMPLICITY	GENet	Logicmaster	Series One	Series 90
CIMPLICITY 90-ADS	Genius	Modelmaster	Series Three	VuMaster
CIMPLICITY PowerTRAC	Genius PowerTRAC	ProLoop	Series Five	Workmaster

## Content of This Manual

- Chapter 1. Introduction:** Discusses the Ethernet Interface, the communications software, and the GENet System Manager.
- Chapter 2. Installing the Ethernet Interface:** Describes the basic features of the Ethernet Interface, the installation and power-up of the Interface, and a procedure for the initial checkout of the Interface on your Ethernet cable.
- Chapter 3. The GENet System Manager–Station Configuration:** Describes the installation and operation of the GENet System Manager and how to configure a Series 90–70 PLC Ethernet Station for a *Basic* Network.
- Chapter 4. The Station Manager:** Describes how to use the Station Manager to provide interactive supervisory access to the Ethernet Interface.
- Chapter 5. General PLC Application Programming:** Explains fundamental features of the interface between the PLC application program and the LAN Interface. Describes how to program the PLC to initiate COMMunication REQuests.
- Chapter 6. OSI COMMunication REQuest:** Defines the OSI service commands and parameter descriptions, and explains how to program each communication request.
- Chapter 7. Station Manager COMMunication REQuest:** Explains how to use the COMM\_REQ in the ladder logic application program to retrieve station management information.
- Chapter 8. Tuning and Configuring Stations for an Advanced Network:** Describes the additional configuration parameters needed to configure and tune stations in an advanced network environment.
- Chapter 9. Troubleshooting:** Describes troubleshooting and problem isolation for the Ethernet Interface.
- Appendix A. Glossary of Terms**
- Appendix B. ISO Networking Concepts**
- Appendix C. Protocol Implementation Conformance Statement (PICS)**
- Appendix D. Communications Port Characteristics**
- Appendix E. Soft Switch Parameters**
- Appendix F. Station Configuration Parameters**
- Appendix G. Ladder Diagrams for Network Testing**
- Appendix H. DOS System Initialization Files**
- Appendix I. Forms**
- Appendix J. GENet System Manager Data Link Error Codes**

## Related Publications

GFK-0262 *Series 90™ – 70 Programmable Controller Installation and Operation*

GFK-0263 *Logicmaster 90™ Programming Software User's Manual*

GFK-0265 *Logicmaster 90™ Programming Software Reference Manual*

GFK-0780 *Logicmaster 90™ –70 – Ethernet User's Manual*

At GE Fanuc Automation, we strive to produce quality technical documentation. After you have used this manual, please take a few moments to complete and return the Reader's Comment Card located on the next page.

## We Welcome Your Comments and Suggestions

At GE Fanuc automation, we strive to produce quality technical documentation. After you have used this manual, please take a few moments to complete and return the Reader's Comment Card located on the next page.

<b>Chapter 1</b>	<b>Introduction</b> .....	<b>1-1</b>
	The Ethernet Communications System .....	1-1
	The Ethernet Interface .....	1-2
	The GEnet System Manager (GSM) .....	1-4
	How to Make it Work .....	1-5
	Quick Guide to the Manual .....	1-6
 <b>Chapter 2</b>	 <b>Installing the Ethernet Interface</b> .....	 <b>2-1</b>
	Ethernet Hardware Overview .....	2-2
	Board Indicators .....	2-3
	Restart Button .....	2-3
	Battery .....	2-4
	Serial Port .....	2-4
	AUI (Transceiver) Port .....	2-4
	Default Station Address Label .....	2-4
	Serial Number Label .....	2-4
	<b>Procedure 1: Installing the Ethernet Interface in the PLC</b> .....	<b>2-5</b>
	Equipment Required to Perform the Installation Procedures .....	2-5
	Ethernet Interface Installation .....	2-5
	<b>Procedure 2: Verifying Proper Power-Up of the Interface</b> .....	<b>2-8</b>
	Using the GSM "Access Station Manager" Function .....	2-8
	States of the Ethernet Interface .....	2-9
	Powering-Up the Interface .....	2-10
	Problems During Power-Up .....	2-11
	<b>Procedure 3: Configuring the Ethernet Interface with Logicmaster 90-70 (PLC Module Configuration)</b> .....	<b>2-12</b>
	<b>Procedure 4: Configuring and Downloading a Station</b> .....	<b>2-13</b>
	Configuring a Station .....	2-13
	Downloading a Station .....	2-14
	Initiating the Download .....	2-15
	Problems During the Download .....	2-16
	How to Issue the LOAD Command from the Station Manager .....	2-16
	<b>Procedure 5: Testing the Interfaces on the Network</b> .....	<b>2-17</b>
	Field Network Test Utility .....	2-17
	Invoking the Field Network Test Utility .....	2-17
	Running Field Network Test .....	2-18

	<b>Procedure 6. Using the Example PLC Ladder Program . . . . .</b>	<b>2-22</b>
	Loading the Example Station Configurations . . . . .	2-22
	Loading the Example PLC Ladder Program . . . . .	2-22
	Executing the Example PLC Ladder Program . . . . .	2-23
	What to Do if the Program is Not Working . . . . .	2-25
	Resuming Normal Operation After Using the Example Program . . . . .	2-26
<b>Chapter 3</b>	<b>The GENet System Manager-Station Configuration . . . . .</b>	<b>3-1</b>
	What is the GSM? . . . . .	3-2
	Why Does a Station Have to be Configured and Downloaded? . . . . .	3-3
	Connecting the GSM to the LAN Interface . . . . .	3-3
	<b>Section 1. Installing and Starting-Up the GSM . . . . .</b>	<b>3-4</b>
	Hardware Requirements . . . . .	3-5
	Installing the PC Network Card (for Network GSM Operation) . . . . .	3-5
	Installing the GENet System Manager (GSM) Software . . . . .	3-6
	Setting-Up DOS System Files . . . . .	3-8
	Local GSM Operation (Exclusively) . . . . .	3-8
	Network GSM Operation (or Both Local and Network) . . . . .	3-8
	Unusual Procedures . . . . .	3-12
	Updating or Adding to Existing GSM Software . . . . .	3-12
	Changing the PC Network Card . . . . .	3-12
	Starting-Up the GSM . . . . .	3-13
	Working Your Way through the GSM Menus . . . . .	3-14
	GSM Keyboard Functions . . . . .	3-15
	GSM Menu Structure . . . . .	3-16

<b>Section 2. Configuring a Station for a Basic Network</b>	<b>3-17</b>
Definition of a Basic Network	3-17
Information Needed to Configure an Ethernet Station for a Basic Network	3-17
Configure a Station Screen	3-19
Creating a Station Configuration File	3-20
Selecting a Station Configuration File	3-21
Deleting a Station Configuration File	3-21
Structure of the MAC Address	3-21
Configuration Editor Menu for Series 90-70 PLCs	3-23
Saving Changes Before Exiting the Configuration Editor Main Menu	3-24
ISO Parameters Menu	3-25
Network Layer Parameters Screen	3-26
Transport / Session Layer Parameters Screen	3-27
ApplicationProcesses Screen	3-28
Local Application DIB Screen	3-30
MMS Parameters Menu	3-31
Variable Names Screen	3-32
Print File Screen	3-34
Configuring a Non-GE Fanuc Device	3-35
Foreign Device Configuration Editor Menu	3-35
Foreign Application Processes Screen	3-37
<b>Section 3. Downloading a Station</b>	<b>3-39</b>
Download Station Screen	3-39
Downloading Locally (Over the Serial Port)	3-39
Downloading Over the Network	3-40
<b>Section 4. Accessing the Station Manager</b>	<b>3-42</b>
Access Station Manager Screen	3-42
<b>Section 5. Using the GSM Support Functions</b>	<b>3-43</b>
List All Stations Screen	3-43
List All Configured Application DIBs Menu	3-44
7-Layer Application DIB Screen	3-45
Setup GSM Menu	3-46
Changing the GSM Password Screen	3-46
Set Download Mode Screen	3-47
Set Station Manager Mode Screen	3-47
Exit to DOS	3-47
<b>Chapter 4 The Station Manager</b>	<b>4-1</b>
<b>Section 1: Accessing the Station Manager</b>	<b>4-2</b>
Accessing the Station Manager Using the GSM	4-3
Accessing the Station Manager Using an ASCII Terminal	4-4
Remote Operation of the Station Manager	4-4
Accessing the Station Manager from the Local PLC	4-5



<b>Section 2: Using the Station Manager .....</b>	<b>4-6</b>
Using the Monitor Commands .....	4-7
Using the Modify Commands .....	4-8
Station Manager Command Syntax .....	4-10
Task Identification .....	4-10
Display Data Representation .....	4-11
Numeric Values .....	4-11
Character Strings Values .....	4-11
Octet String Values .....	4-11
Object Identifier Values .....	4-11
Station Manager in Utility Programs .....	4-12
Soft Switch Entry Utility .....	4-12
Field Network Test Utility .....	4-14

<b>Section 3: Station Manager Command Descriptions . . . . .</b>	<b>4-16</b>
Command Input Processing . . . . .	4-16
ACB Command . . . . .	4-17
BPS Command . . . . .	4-17
CAP Command . . . . .	4-18
CHBPS Command . . . . .	4-18
CHDATE Command . . . . .	4-18
CHLTIME Command . . . . .	4-19
CHSOSW Command . . . . .	4-19
CHTIME Command . . . . .	4-21
CLEAR Command . . . . .	4-22
CLSOSW Command . . . . .	4-22
DATE Command . . . . .	4-23
EXS Command . . . . .	4-23
HELP Command . . . . .	4-24
LOAD Command . . . . .	4-25
LOG Command . . . . .	4-25
LOGIN Command . . . . .	4-26
LOGOUT Command . . . . .	4-27
LTIME Command . . . . .	4-27
MDIB Command . . . . .	4-28
NET Command . . . . .	4-28
NODE Command . . . . .	4-29
OK Command . . . . .	4-29
PI Command . . . . .	4-29
REM Command . . . . .	4-30
REPORT Command . . . . .	4-31
RESTART Command . . . . .	4-32
RIB Command . . . . .	4-32
SHOW Command . . . . .	4-33
SOSW Command . . . . .	4-36
STAT Command . . . . .	4-36
STOPT Command . . . . .	4-37
TALLY Command . . . . .	4-37
TEST Command . . . . .	4-43
TIME Command . . . . .	4-44
TRACE Command . . . . .	4-45
VAR Command . . . . .	4-47
VMD Command . . . . .	4-47

<b>Chapter 5</b>	<b>General PLC Application Programming .....</b>	<b>5-1</b>
	Commands Supported Through Ladder Logic .....	5-1
	Communications Commands .....	5-1
	Station Manager Commands .....	5-2
	Programming COMMunication REQuests .....	5-2
	Using the COMM_REQ Instruction .....	5-3
	Device Independent Area .....	5-3
	Message Definition Block .....	5-4
	Programming a COMM_REQ .....	5-5
	The LAN Interface Status Word .....	5-7
	Location of the LAN Interface Status Word .....	5-7
	Contents of the LAN Interface Status Word .....	5-8
	General Tips on Ladder Programming .....	5-9
 <b>Chapter 6</b>	 <b>MMS COMMunications REQuests .....</b>	 <b>6-1</b>
	OSI Reference Model .....	6-1
	OSI Application Layer .....	6-1
	Message Flow in the OSI Model .....	6-2
	Series 90-70 Ethernet Interface Application Processes .....	6-2
	MMS Responder .....	6-2
	Application Interface .....	6-3
	Selecting the Application Process .....	6-4
	Programming Communications COMM_REQs .....	6-5
	Association Control Block .....	6-7
	General Association Status Bits .....	6-7
	Request Completion .....	6-8
	Association Status Word .....	6-9
	Association Status Word Extension .....	6-10
	MMS COMM_REQ Command Descriptions .....	6-11
	Association Services .....	6-11
	Initiate Request Command - 8201 .....	6-11
	Initiate Indication Service .....	6-12
	Examine Initiate Indication Command - 8202 .....	6-13
	Initiate Response Command - 8203 .....	6-15
	Initiate Confirmation Service .....	6-16
	Examine Positive Initiate Confirm Command - 8204 .....	6-17
	Conclude Request Command - 8205 .....	6-18
	Conclude Indication Service .....	6-18

Conclude Response Command - 8206 .....	6-19
Conclude Confirm Service .....	6-19
Abort Request Command - 8207 .....	6-20
Abort Indication Service .....	6-20
Examine Association Options Command - 8300 .....	6-21
Memory Access Services .....	6-24
Overview .....	6-24
Read Request Command - 8322 .....	6-28
Read Indication Service .....	6-30
Read Confirm Service .....	6-30
Write Request Command - 8323 .....	6-31
Write Indication Service .....	6-32
Write Confirm Service .....	6-33
InformationReport Request Command - 8320 .....	6-34
InformationReport Indication Service .....	6-35
Examine InformationReport Indication Variable Command - 8321 .....	6-36
Transfer InformationReport Indication Data Command - 8330 .....	6-37
Discard InformationReport Indication Data Command - 8339 .....	6-38
Program Invocation Management Services .....	6-39
PI Commands .....	6-39
Start Request Command - 8304 .....	6-40
Start Indication Service .....	6-41
Examine Start Indication Command - 8305 .....	6-41
Start Response Command - 8306 .....	6-42
Stop Request Command - 8307 .....	6-43
Stop Indication Service .....	6-43
Examine Stop Indication Command - 8308 .....	6-44
Stop Response Command - 8309 .....	6-45
Reset Request Command - 8310 .....	6-46
Reset Indication Service .....	6-46
Examine Reset Indication Command - 8311 .....	6-47
Reset Response Command - 8312 .....	6-47
Resume Request Command - 8313 .....	6-48
Resume Indication Service .....	6-49
Examine Resume Indication Command - 8314 .....	6-49
Resume Response Command - 8315 .....	6-50
Set Local ProgramInvocation Processing - 8356 .....	6-51
Set Local ProgramInvocation State Command - 8355 .....	6-52
Status Services .....	6-53

	Status Request Command - 8250 .....	6-53
	Status Indication Service .....	6-54
	Status Response Command - 8251 .....	6-54
	Status Confirm Service .....	6-55
	Unsolicited Status Request - 8252 .....	6-55
	Unsolicited Status Indication Service .....	6-56
	Examine UnsolicitedStatus Indication Command - 8253 .....	6-56
	Set Local VMD Status Command - 8353 .....	6-57
	Miscellaneous OSI Services .....	6-59
	Identify Request Command - 8240 .....	6-59
	Identify Confirm Service .....	6-60
	Cancel Request Command - 8290 .....	6-61
	Get Remote Name List Command - 8301 .....	6-62
	Error Request Command - 8350 .....	6-64
	Reject Indication Service .....	6-65
	Examine Reject Indication Command - 8351 .....	6-65
	Error Indication Service .....	6-65
	Examine Last Error Information Command - 8352 .....	6-66
	Define Application Command - 8200 .....	6-67
	MMS Error Encodings .....	6-68
<b>Chapter 7</b>	<b>Station Manager COMMunications REQuests .....</b>	<b>7-1</b>
	Station Manager Ladder Requests .....	7-1
	Retrieve Extended Status Buffer Request - 8100 .....	7-2
	Retrieve Tallies Request - 8101 .....	7-4
	Retrieve Log Events Request - 8102 .....	7-6
	Restart Ethernet Interface Request - 8103 .....	7-7
<b>Chapter 8</b>	<b>Tuning and Configuring Stations for an Advanced Network .....</b>	<b>8-1</b>
	Definition of an Advanced Network .....	8-1
	Using this Chapter .....	8-1
	Configure a Station Screen .....	8-2
	Defining a Station .....	8-3
	Selecting a Station .....	8-4
	Deleting a Station .....	8-4

	<b>Section 1: Configuring a Series 90-70 PLC Station</b> .....	<b>8-5</b>
	Configuration Editor Main Menu for the Series 90-70 PLC .....	8-5
	Saving Changes Before Exiting the Configuration Editor Main Menu ..	8-6
	Menu Structure .....	8-6
	ISO Parameters Menu .....	8-7
	Data Link Parameters Screen .....	8-8
	Network Layer Parameters Screen .....	8-10
	Network Layer RIB Table Screen .....	8-12
	Transport / Session Layer Parameters Screen .....	8-14
	Application Processes Screen .....	8-16
	Abstract and Transfer Syntaxes Screen .....	8-18
	Association Parameters Screen .....	8-19
	Local Application DIB Screen .....	8-20
	MMS Parameters Menu .....	8-21
	Variable Names Screen .....	8-22
	Maximum MMS Message Size Screen .....	8-24
	System Parameters Screen .....	8-25
	Print File Screen .....	8-28
	<b>Section 2: Configuring Network-Wide Parameters</b> .....	<b>8-29</b>
	Configure Network-Wide Parameters Menu .....	8-29
	Load Group Parameters Screen .....	8-30
<b>Chapter 9</b>	<b>Troubleshooting</b> .....	<b>9-1</b>
	Overview .....	9-1
	Using this Chapter .....	9-2
	What to do if you Cannot Solve the Problem .....	9-4
	The Power-up State .....	9-5
	The Soft Switch Entry State .....	9-5
	The Field Network Test State .....	9-6
	The Loader State .....	9-7
	The Operational State .....	9-8
	Troubleshooting When STATUS OK LED is OFF .....	9-8
	Troubleshooting When the STATUS OK LED is ON .....	9-9
	Exception Log Event Error Codes .....	9-10
	Extended Status Buffer Negative Values .....	9-27
	Extended Status Buffer Errors .....	9-27
	GEnet LAN Interface Status Word .....	9-30
<b>Appendix A</b>	<b>Glossary of Terms</b> .....	<b>A-1</b>
	Commonly Used Acronyms and Abbreviations .....	A-1
	Glossary of Terms .....	A-3

<b>Appendix B</b>	<b>ISO Networking Concepts</b> .....	<b>B-1</b>
	OSI Reference Model .....	B-2
	Protocols Used for GE Fanuc Control Devices .....	B-3
	Implementation of the OSI Model in GE Fanuc Control Devices .....	B-4
	Mapping MMS Services to ACSE and Presentation Services .....	B-4
	OSI Addressing .....	B-5
	Protocol Data Transfer .....	B-6
	OSI Application Layer .....	B-7
	Locating Applications .....	B-10
	The Client–Server Model .....	B-10
	MMS Objects and Their Attributes .....	B-11
	Object Scope .....	B-12
	The Virtual Manufacturing Device (VMD) Object .....	B-12
	Capability Objects .....	B-17
	Domain Objects .....	B-17
	Program Invocation Objects .....	B-21
	Variable Objects .....	B-24
	Operator Station Objects (CNC Only) .....	B-25
	MMS Variable Mapping (Series 90-70 PLC Only) .....	B-27
	Boolean Data .....	B-27
	Bit String Data .....	B-28
	Signed and Unsigned Integers .....	B-29
	Floating Point .....	B-29
	Octet Strings and Visible Strings .....	B-29
	Object Scope .....	B-29
	Series 90-70 PLC Application .....	B-30
	Naming and Addressing .....	B-30
<b>Appendix C</b>	<b>Protocol Implementation Conformance Statement (PICS)</b> .....	<b>C-1</b>
	PICS for the Manufacturing Message Specification (MMS) .....	C-1
<b>Appendix D</b>	<b>Communication Ports Characteristics</b> .....	<b>D-1</b>
	Serial Port for Local GSM Communications .....	D-2
	Serial Port Settings .....	D-2
	Serial Port Pinouts .....	D-2
	Serial Cable .....	D-2
	Display Terminal Settings .....	D-3
	The AUI Port for the Ethernet Interface .....	D-4
	Ethernet AUI Port Pinouts .....	D-4
	AUI (Transceiver Cable) .....	D-5
	Transceiver Description .....	D-6

<b>Appendix E</b>	<b>Soft Switch Parameters</b> .....	<b>E-1</b>
	Station Address .....	E-1
	Load Source .....	E-2
	LAN Online .....	E-2
	Backplane Online .....	E-2
	Network Load Address .....	E-2
	Modify Soft Switch Settings .....	E-3
	Configuring Soft Switch Parameters .....	E-4
	Configuring Soft Switch Parameters Using the GSM .....	E-4
	Correct Results of Soft Switch Configuration .....	E-5
<b>Appendix F</b>	<b>Station Configuration Parameters</b> .....	<b>F-1</b>
	Configuration Parameters via the Station Manager .....	F-1
<b>Appendix G</b>	<b>Ladder Programs for Network Testing</b> .....	<b>G-1</b>
	Sample Ladder Program .....	G-1
<b>Appendix H</b>	<b>Sample DOS System Files</b> .....	<b>H-1</b>
	Sample DOS Initialization Files .....	H-2
	3Com Etherlink II .....	H-2
	3Com Etherlink 16 .....	H-3
	3Com Etherlink/MC .....	H-4
	Western Digital EtherCard PLUS, EtherCard PLUS Elite 16, EtherCard PLUS/A ..	H-5
	Intel 82593 .....	H-6
	Xircom Pocket Adapter .....	H-7
	SMC EtherCard PLUS, EtherCard PLUS Elite 16, EtherCard PLUS/A ..	H-8
	Optimizing the GSM for Network Operation .....	H-9
<b>Appendix I</b>	<b>Forms</b> .....	<b>I-1</b>
<b>Appendix J</b>	<b>GEnet System Manager Data Link Error Codes</b> .....	<b>J-1</b>



Figure 1-1. Major Components of the GENet 802.3 LANN .....	1-1
Figure 1-2. The Main Tasks for Installing the Ethernet Communications System .....	1-5
Figure 2-1. Ethernet Controller Board .....	2-2
Figure 2-2. Ethernet Controller Installation in the Series 90-70 PLC .....	2-6
Figure 2-3. Ethernet Interface Installation in an Expansion Rack .....	2-7
Figure 2-4. States of the Ethernet Interface .....	2-9
Figure 3-1. GENet System Manager (GSM) on 802.3 LAN .....	3-1
Figure 3-2. GSM Main Menu .....	3-13
Figure 3-3. GSM Menu Structure .....	3-16
Figure 3-4. Configure a Station Screen .....	3-19
Figure 3-5. Configuration Editor Menu .....	3-23
Figure 3-6. ISO Parameters Menu .....	3-25
Figure 3-7. Network Layer Parameters Screen .....	3-26
Figure 3-8. Transport/SessionLayerParameters Screen .....	3-27
Figure 3-9. Application Processes Screen .....	3-28
Figure 3-10. Local Application DIB Screen .....	3-30
Figure 3-11. MMS Parameters Menu .....	3-31
Figure 3-12. Variable Names Screen .....	3-32
Figure 3-13. Print File Screen .....	3-34
Figure 3-14. Foreign Device Configuration Editor Menu .....	3-36
Figure 3-15. Foreign Application Processes Screen .....	3-37
Figure 3-16. Download Station Screen .....	3-39
Figure 3-17. Access Station Manager Screen .....	3-42
Figure 3-18. List All Stations Screen .....	3-43
Figure 3-19. List All Configured Applications Menu .....	3-44
Figure 3-20. 7-Layer Application DIB Screen .....	3-45
Figure 3-21. Setup GSM Menu .....	3-46
Figure 4-1. Station Manager Accessed Locally through the 9-pin Serial Port by a GSM in Local Station Manager Mode (or an ASCII Terminal) .....	4-2
Figure 4-2. Station Manager Accessed Directly over the Network by a GSM in Network Station Manager Mode .....	4-2
Figure 4-3. Station Manager Accessed Remotely over the Network by a GSM in Local Station Manager Mode using the REM (Remote) Command ..	4-3
Figure 5-1. General Format for COMM_REQs .....	5-2
Figure 6-1. Message Types, Time Sequence .....	6-2
Figure 6-2. Association Status Word Extension Bits .....	6-10
Figure 8-1. Configure a Station Screen .....	8-2
Figure 8-2. Configuration Editor Main Menu .....	8-5

---

Figure 8-3. ISO Parameters Menu .....	8-7
Figure 8-4. Data Link Parameters Screen .....	8-8
Figure 8-5. Network Layer Parameters Screen .....	8-10
Figure 8-6. Network Layer RIB Table Screen .....	8-12
Figure 8-7. Specifying Automatic or Static Routing .....	8-13
Figure 8-8. Transport/SessionLayerParameters Screen .....	8-14
Figure 8-9. Application Processes Screen .....	8-16
Figure 8-10. Abstract and Transfer Syntaxes Screen .....	8-18
Figure 8-11. Association Parameters Screen .....	8-19
Figure 8-12. Local Application DIB Screen .....	8-20
Figure 8-13. MMS Parameters Menu .....	8-21
Figure 8-14. Variable Names Screen .....	8-22
Figure 8-15. Maximum MMS Message Size Screen .....	8-24
Figure 8-16. System Parameters Screen .....	8-25
Figure 8-17. Print File Screen .....	8-28
Figure 8-18. Configure Network-Wide Parameters Menu .....	8-29
Figure 8-19. Load Group Parameters Screen .....	8-30
Figure 9-1. Determining the State of the Ethernet Interface .....	9-4
Figure 9-2. Meaning of GENet LAN Interface Status Inputs .....	9-30
Figure B-1. OSI-Reference Model .....	B-2
Figure B-2. Relationship between Tasks and Layers of GE Fanuc Control Devices .....	B-4
Figure B-3. Service Access Points for the OSI Layers .....	B-5
Figure B-4. Attachment of Protocol Control Information to form the Protocol Data Unit .....	B-6
Figure B-5. Attachment of Protocol Control Information throughout the ISO Stack .....	B-6
Figure B-6. Application Process Concept .....	B-8
Figure B-7. Series 90-70 PLC Application Process Implementation .....	B-8
Figure B-8. CNC Application Process Implementation .....	B-9
Figure B-9. MMS Object Identifier .....	B-10
Figure B-10. Acknowledged MMS Service .....	B-11
Figure B-11. MMS VMD Attributes and Contained Objects .....	B-13
Figure B-12. Domain State Diagram .....	B-18
Figure B-13. Program Invocation State Diagram (PI State) .....	B-22
Figure B-14. Operator Station State Diagram .....	B-26
Figure B-15. MMS Boolean Data Memory Mapping .....	B-28
Figure B-16. MMS Bit String Data Memory Mapping .....	B-28
Figure B-17. MMS Object Identifier .....	B-30
Figure D-1. Serial Cable to Connect GSM (25-Pin Connector) to Ethernet Interface .....	D-2
Figure D-2. Serial Cable to Connect GSM (9-Pin Connector) to Ethernet Interface .....	D-3
Figure D-3. Transceiver Cable Connection .....	D-5
Figure D-4. 10Base2 Transceiver Configuration .....	D-6
Figure D-5. 10Base5 Transceiver Configuration .....	D-6

Table 2-1. Ethernet Controller Board Indicators .....	2-3
Table 3-1. 802.3/Ethernet Cards for the PC .....	3-5
Table 3-2. Default PC Hardware Settings for 802.3/Ethernet Cards .....	3-6
Table 3-3. GSM Keyboard Functions (Alt-K) .....	3-15
Table 4-1. Monitor Commands .....	4-7
Table 4-2. Modify Commands .....	4-9
Table 4-3. Task Identifiers .....	4-10
Table 4-4. Soft Switch Entry Utility Commands .....	4-13
Table 4-5. Field Network Test Utility Commands .....	4-15
Table 4-6. Control Characters .....	4-16
Table 4-7. Load Source Parameters .....	4-20
Table 4-8. Soft Switch Default Values for the Ethernet Interface .....	4-21
Table 4-9. Exception Log Event Definitions .....	4-26
Table 4-10. Configuration Parameters .....	4-34
Table 4-11. Application Layer Tallies (Tally a) .....	4-37
Table 4-12. System Memory Tallies (Tally b) .....	4-38
Table 4-13. PLC Driver Tallies (Tally c) .....	4-38
Table 4-14. Distributed Directory Protocol (DDP) Tallies (Tally d) .....	4-38
Table 4-15. ACSE Tallies (Tally e) .....	4-39
Table 4-16. Data Link Tallies (part of Tally l) .....	4-39
Table 4-17. MAC Layer Tallies (part of Tally l) .....	4-40
Table 4-18. MMS Provider Tallies (Tally m) .....	4-40
Table 4-19. Network Layer Tallies (Tally n) .....	4-41
Table 4-20. Presentation Layer Tallies (Tally p) .....	4-41
Table 4-21. Session Layer Tallies (Tally s) .....	4-41
Table 4-22. Transport Layer Tallies (Tally t) .....	4-42
Table 4-23. SRTP Service Agent Tallies (Tally v) .....	4-42
Table 5-1. Format of the COMM_REQ Device Independent Area .....	5-3
Table 5-2. Values for the CRSW Memory Type .....	5-4
Table 5-3. CRSW Interpretation .....	5-4
Table 5-4. Block Move Instruction Operands .....	5-6
Table 5-5. The LAN Interface Status Word .....	5-8
Table 6-1. Example Application Common Names .....	6-4
Table 6-2. PLC Communications Commands .....	6-6
Table 6-3. Association Control Block .....	6-7
Table 6-4. Initiate Request COMM_REQ .....	6-11
Table 6-5. Examine Initiate Indication COMM_REQ .....	6-13

Table 6-6. Examine Initiate Indication Data .....	6-13
Table 6-7. Initiate Response COMM_REQ .....	6-15
Table 6-8. Examine Positive Initiate Confirm Data .....	6-17
Table 6-9. Generic Examine COMM_REQ .....	6-17
Table 6-10. Conclude Request COMM_REQ .....	6-18
Table 6-11. Conclude Response COMM_REQ .....	6-19
Table 6-12. Abort Request COMM_REQ .....	6-20
Table 6-13. Examine Association Options Data .....	6-21
Table 6-14. Parameter Conformance Building Blocks .....	6-21
Table 6-15. Remote Peer Services Supported .....	6-22
Table 6-16. Series 90-70 PLC Memory Organization .....	6-25
Table 6-17. Series 90-70 PLC Symbolic Addresses .....	6-26
Table 6-18. Read Request COMM_REQ .....	6-28
Table 6-19. Data Type Values .....	6-29
Table 6-20. Variable Type Values .....	6-29
Table 6-21. Write Request COMM_REQ .....	6-31
Table 6-22. InformationReport Request COMM_REQ .....	6-34
Table 6-23. InformationReport Element Numbers .....	6-35
Table 6-24. Examine InformationReport Indication Variable Data .....	6-36
Table 6-25. Transfer InformationReport Indication Data COMM_REQ .....	6-37
Table 6-26. Information Report Data .....	6-37
Table 6-27. Discard InformationReport Indication Data COMM_REQ .....	6-38
Table 6-28. Start Request COMM_REQ .....	6-40
Table 6-29. Examine Start/Resume Indication Data .....	6-41
Table 6-30. Start Response COMM_REQ .....	6-42
Table 6-31. Stop Request COMM_REQ .....	6-43
Table 6-32. Examine Stop/Reset Indication Data .....	6-44
Table 6-33. Stop Response COMM_REQ .....	6-45
Table 6-34. Reset Request COMM_REQ .....	6-46
Table 6-35. Reset Response COMM_REQ .....	6-47
Table 6-36. Resume Request COMM_REQ .....	6-48
Table 6-37. Resume Response COMM_REQ .....	6-50
Table 6-38. Set Local ProgramInvocation Processing COMM_REQ .....	6-51
Table 6-39. Set Local ProgramInvocation State COMM_REQ .....	6-52
Table 6-40. ProgramInvocation State Values .....	6-52
Table 6-41. Status Request COMM_REQ .....	6-53
Table 6-42. Status Response COMM_REQ .....	6-54

---

Table 6-43. Status Buffer .....	6-55
Table 6-44. UnsolicitedStatus Request COMM_REQ .....	6-55
Table 6-45. Examine UnsolicitedStatus Indication COMM_REQ .....	6-56
Table 6-46. Set Local VMD Status COMM_REQ .....	6-57
Table 6-47. VMD Logical Status Values .....	6-57
Table 6-48. VMD Physical Status Values .....	6-57
Table 6-49. Identify Request COMM_REQ .....	6-59
Table 6-50. Identify Positive Confirm Data .....	6-60
Table 6-51. Cancel Request COMM_REQ .....	6-61
Table 6-52. Get Remote Name List COMM_REQ .....	6-62
Table 6-53. Object Class Values .....	6-63
Table 6-54. Object Scope Values .....	6-63
Table 6-55. Get Remote Name List Data .....	6-64
Table 6-56. Error Request COMM_REQ .....	6-64
Table 6-57. Examine Reject Indication Data .....	6-65
Table 6-58. Examine Last Error Information Data .....	6-66
Table 6-59. Define Application COMM_REQ .....	6-67
Table 6-60. MMS Error Values .....	6-69
Table 6-61. Data Access Errors .....	6-70
Table 6-62. MMS Reject Values .....	6-70
Table 7-1. Station Manager PLC Commands .....	7-1
Table 7-2. Retrieve Extended Status Buffer Request COMM_REQ .....	7-2
Table 7-3. Extended Status Buffer Data .....	7-2
Table 7-4. Retrieve Tallies Request COMM_REQ .....	7-4
Table 7-5. Tallies Structure and Offsets .....	7-5
Table 7-6. Retrieve Log Events Request COMM_REQ .....	7-6
Table 7-7. Event Log Format .....	7-6
Table 7-8. Restart Ethernet Interface Request COMM_REQ .....	7-7
Table 9-1. Ethernet Interface Diagnostic Tools .....	9-2
Table 9-2. Power-Up State .....	9-5
Table 9-3. Soft Switch Entry State .....	9-6
Table 9-4. Field Network Test State .....	9-6
Table 9-5. Loader State .....	9-7
Table 9-6. Operational State .....	9-8
Table 9-7. Troubleshooting with ONLINE LED OFF .....	9-9
Table 9-8. Troubleshooting with ONLINE LED ON .....	9-10
Table 9-9. Exception Log Event Definitions .....	9-10

Table 9-10. Exception Log Event Codes .....	9-11
Table 9-11. Negative Extended Status Buffer Values .....	9-27
Table 9-12. Extended Status Buffer Error Codes and Definition .....	9-27
Table B-1. Protocol Used for GE Fanuc Control Devices .....	B-3
Table B-2. MMS Service Mapping to ACSE and Presentation Services .....	B-4
Table B-3. Effect of VMD Logical State and CNC Mode on MMS Services .....	B-16
Table B-4. Domain Attributes .....	B-18
Table B-5. Domain States .....	B-20
Table B-6. Program Invocation Attributes .....	B-21
Table B-7. Program Invocation States .....	B-23
Table B-8. Variable Access Attributes .....	B-24
Table B-9. GE Fanuc Control Device Data Types .....	B-25
Table B-10. Operator Station Attributes .....	B-25
Table B-11. MMS Variable Types and Size .....	B-27
Table C-1. PICS Series 90-70 PLC System ID Information .....	C-1
Table C-2. PICS Supported Services .....	C-2
Table C-3. PICS Supported Parameters .....	C-3
Table C-4. PICs Range of Values .....	C-3
Table D-1. Pinouts of the Serial Port .....	D-2
Table D-2. Pinouts of the AUI Port .....	D-4
Table E-1. Soft Switch Settings .....	E-3
Table F-1. Configuration Parameters via the Station Manager .....	F-1
Table I-1. MMS–Ethernet Station Configuration Data* .....	I-2
Table I-2. Foreign Device Station Configuration Data .....	I-3

# Chapter 1

## Introduction

This manual describes the *Ethernet Interface* and the *GENet™ System Manager Software (GSM)*, which together form a complete Ethernet Communications System for the Series 90-70 PLC. These products are members of the GENet Factory LAN family of hardware and software products. The GENet family of products provides high performance solutions for interconnecting automation controllers and for integrating them into multi-vendor networks.

This chapter provides an overview of the product and covers the following topics.

- The Ethernet Communications System,
- How to Make the System Work,
- Quick Guide to the Manual.

## The Ethernet Communications System

The Figure 1-1 shows the major components of the GENet Factory LAN, along with a third-party compatible device, together on one Ethernet cable. Note especially the two main parts of the Ethernet Communications system, the *Ethernet Interface* and the *GENet System Manager Software*, and the separation of functions between them.

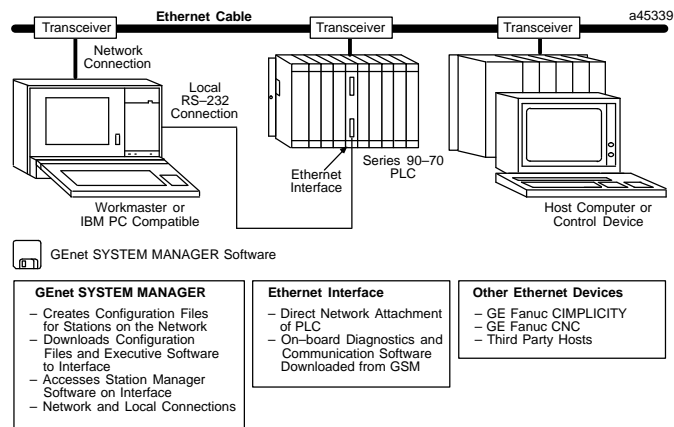

Figure 1-1. Major Components of the GENet 802.3 LANN

The *Ethernet Interface* allows you to directly attach the Series 90–70 PLC to an Ethernet LAN via a user-supplied transceiver and AUI cable, and to access hosts and other control devices on the network. Using standard OSI Communications, including MMS (Manufacturing Message Specification), this interface is compatible with other products from within GE Fanuc, as well as from other vendors.

The communications services most important to your application are supported, including:

- Data transfer, and
- Status indications.

## The Ethernet Interface

An operational *Ethernet Interface* consists of the controller board with resident firmware and the software downloaded from the GENet System Manager. The controller board provides a physical connection from the PLC to the Ethernet LAN. It also is shipped with on-board diagnostics, a download program to complement the downloader on the *GENet System Manager*, and a utility program that permits testing the cable plant. The controller board becomes a fully functional communications interface only after downloading additional software from the *GENet System Manager*.

### Capabilities of the Ethernet Interface

The Ethernet interface brings to your PLC a great deal of capability. It will allow you to:

- **Directly attach your PLC to a 802.3 CSMA/CD network.**
- **Transfer data to and from the PLC from another device.** This transfer can occur at high speeds, and can come from a Host computer, or from other control devices such as CNCs and other PLCs.
- **Communicate simultaneously to multiple devices.** The multiplexing capabilities of the Ethernet network, along with Ethernet's high capacity, allow the PLC to hold communications with several other devices at the same time.
- **Compatibility with other GE Fanuc devices, as well as with devices from other vendors.** The GE Fanuc Series 90–70 PLC is compatible with the CNC Ethernet Interface and the CIMPLICITY™ Host Application. It is also compatible with various Ethernet products available on DEC, HP, IBM, and other computer platforms.
- **Communicate from a Host computer (or other control device).** The host can access data within the PLC, without specific host knowledge about the PLC's internal data layout. This is accomplished through the data naming that is inherent in MMS. Data within the PLC can be rearranged without the need for reprogramming the host.
- **Diagnose and maintain your system, using diagnostic and station management tools.** You can find problems before they become serious, and when communications software upgrades are desired, you can use your network to download the software to the interface.



## Attachment of the Ethernet Interface to the LAN

The AUI port provides the electrical and mechanical interface to the user-provided IEEE 802.3 transceiver cable, which connects the AUI port to an external user-provided transceiver. The external transceiver is directly connected to the Ethernet cable.

Various Ethernet baseband media (10 Base..) can be interconnected by appropriate repeaters. Capabilities and limitations are defined in IEEE 802.3 Chapter 13, "System Considerations for Multi-Segment Networks".

The Ethernet Controller can operate on any of the following media with the appropriate user-supplied transceiver cable and transceiver. IEEE 802.3 specifies the definitive requirements of each medium.

**10Base5 Coax:** 10Base5 uses a 0.4 inch diameter 50-ohm coaxial cable. The maximum length of a cable segment (single span of cable) is 500 meters. The distance between any two stations must be a multiple of 2.5 meters. A maximum of 100 stations is allowed on a thickwire Ethernet segment.

**10Base2 Coax:** 10Base2 uses a 0.2 inch diameter 50-ohm coaxial cable. The maximum length of a thinwire cable segment is 185 meters. A maximum of 30 stations is allowed on a thinwire Ethernet segment.

**10BaseT:** 10BaseT uses a twisted pair cable of up to 100 meters in length between each node and a hub or repeater. Typical hubs or repeaters support 6 to 12 nodes connected in a star wiring topology.

**10BaseF:** 10BaseF has two variations that both use the same type of fiberoptic cable: 10BaseFP can support up to 33 nodes at distances of up to 500 meters from a passive star; 10BaseFL supports up to 2000 meters between a node and a repeater (a multi-port repeater would thus constitute a star). Additionally, 10BaseFB provides a means of interconnecting (only) repeaters by up to 2000 meters of (the same) fiber optic cable.

**10Broad36:** 10Broad36 uses 75-ohm coaxial cable and CATV-like media components (taps, amplifiers, headend translators, etc.) to support hundreds of nodes at distances of up to 2800 meters. Broadband cannot be connected to baseband via repeaters. Broadband cable plant design and installation must be in accordance with IEEE 802.7 and requires special expertise. GE Fanuc recommends you contract professional specialists for these services. Consult your GE Fanuc sales representative or field service office for help in identifying local specialists.

## The Ethernet Software

As stated above, the *Ethernet Interface* becomes fully functional only after additional software is downloaded from the *GENet System Manager*. The downloaded software consists of:

**The Station Manager.** The Station Manager provides On-Line supervisory access to the Interface, through either the serial port on the controller board or over the Ethernet cable. These Station Manager services on the Ethernet Interface include:

- An interactive set of commands for interrogating and controlling the station.
- Unrestricted access to observe internal statistics, an exception log, and configuration parameters.
- Password security for commands that change station parameters or operation.

**Communications Software.** This software consists of the 7-layer ISO protocol stack and interface software interfacing the protocol stack with the PLC.

**Configuration File.** This configuration data consists largely of timing, buffer, addressing, and other parameters for each station on the network.

## The GEnet System Manager (GSM)

The *GEnet System Manager* is a menu-driven software package that runs on a user-provided IBM PC or equivalent running DOS 5.0. The GSM provides various management and configuration tools. The GSM can be connected to the *Ethernet Interface* either with a serial RS-232 cable, or over the Ethernet cable. When used over Ethernet, one GSM can conveniently access any of the *Ethernet Interfaces* on that cable.

The most essential GSM tools are:

- The Configuration Editor
- The Downloader
- Access to the Station Manager on the *Ethernet Interface*

In addition, the GSM has the following functions:

- Examine the list of configured *Ethernet Interfaces*.
- Examine and modify network-wide configuration parameters.
- Create and examine the application Directory Information Bases (DIBs). The GSM also can create files containing these DIBs.

### Note

Typically, there will be only one GSM on the network. It will contain configuration information and communications software for all the GEnet stations on the network.

## The Configuration Editor

The Configuration Editor is a menu-driven software package that is part of the GSM. It is used offline to examine and modify configuration parameters for all the GEnet *Ethernet Interfaces* on your network. These configuration parameters are stored in files on the PC hard disk and subsequently downloaded to the interface using the GSM Downloader.

## The Downloader

The Downloader is a utility which transfers the Communications Software and the Configuration File to the *Ethernet Interface*. The Downloader operates in two modes, *local (RS232)* and *network*. The Downloader and the download mode are selected in the main screen of the GSM.

## Access to the Station Manager on the Ethernet Interface

The *Ethernet Interface* provides an interactive maintenance interface called the Station Manager (described in Chapter 4). The Station Manager allows you to view current and historical information about the operation of the Ethernet Interface. The GSM provides access to the Ethernet Interface and Station Manager in both *local* and *network* modes.

Access to the Station Manager and the access mode are selected in the main screen of the GSM.

## How to Make it Work

There are a number of tasks required to get your Ethernet Communications System working. These tasks involve not only the *Ethernet Interface* and the *GENet System Manager Software*, but also *Logmaster Configuration* and depending on your applications, *Programming Software*. The figure below illustrates what the tasks are for each part of the system.

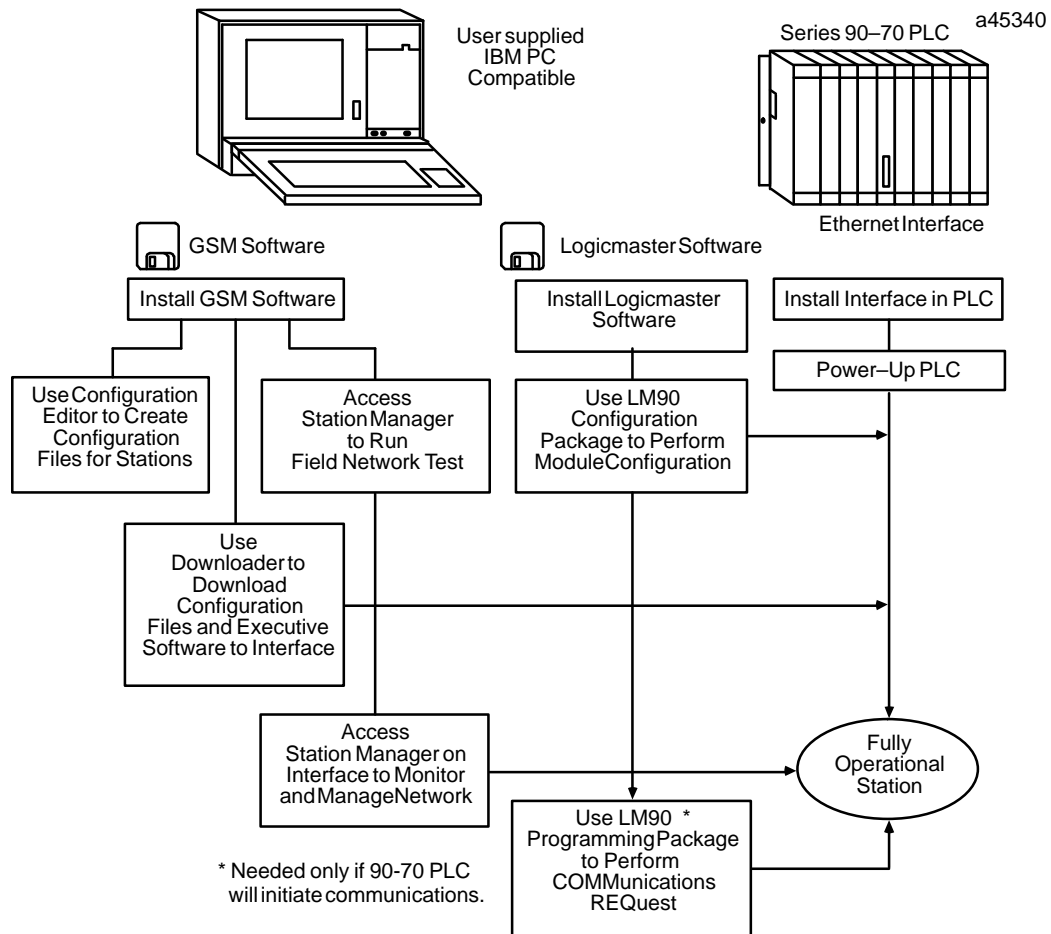

Figure 1-2. The Main Tasks for Installing the Ethernet Communications System

## Quick Guide to the Manual

As you can see from Figure 1-2, the tasks to install the Ethernet Communications System take three paths.

1. GENet System Manager (GSM) Tasks
2. Logicmaster Configuration and Programming Tasks
3. Ethernet Interface Tasks

The table below breaks down these tasks and identifies where in the manual they are described.

Tasks	Where to go in the Manual
<b>GENet System Manager (GSM)</b> Installing, Starting Up, and Using the GSM  Configuring Stations for a Basic Network  ISO Parameters (General Info.) MMS Parameters Configuring Stations for an Advanced Network Downloading a Station  Accessing the Station Manager (Terminal Emulation Mode)	Chapter 3. The GENet System Manager Section 1. Installing and Starting-Up the GSM Appendix H Sample DOS system files  Chapter 3. The GENet System Manager Section 2. Configuring Stations for a Basic Network  Appendix B. ISO Networking Concepts Appendix B. ISO Networking Concepts  Chapter 8. Tuning and Configuring Stations for an Advanced Network  Chapter 3. The GENet System Manager Section 3. Downloading a Station  Chapter 3. The GENet System Manager Section 4. Accessing the Station Manager Chapter 4. The Station Manager
<b>Logicmaster Programming</b> Using the Example PLC Ladder Program Programming COMMunications REQuests	Procedure 7. Using the Example PLC Ladder Program  Chapter 5. General PLC Application Programming Chapter 6. OSI COMMunication REQuest Chapter 7. Station Manager COMMunication REQuest
<b>Ethernet Interface</b> Installing the Interface  Powering-Up the Interface  Configuring the Module (Setting Soft Switch Configuration)  Field Network Tests  Monitoring the Station and Managing the Network Troubleshooting the Interface on the Network	Chapter 2. Installing the Ethernet Interface Procedure 1. Installing the Interface Procedure 2. Verifying Proper Power-Up of the Interface Procedure 3. Configuring the Interface with the Logicmaster 90-70 Configurator  Procedure 5. Testing the Interface on the Network  Chapter 4. The Station Manager  Chapter 9. Troubleshooting

# Chapter 2

## *Installing the Ethernet Interface*

---

---

This chapter describes the basic features of the Ethernet Interface, the installation of the interface, and a procedure for the initial checkout of the interface on your Ethernet cable. The chapter first provides a hardware overview of the Ethernet Interface. It is then divided into six Installation Procedures, each providing an overview of the procedure, explaining the steps to be performed, and describing the expected results.

As you work through a procedure you may encounter references to the appendices and other chapters in this manual. These references provide more detailed information about the subject under discussion.

The installation procedures described in this chapter are listed below:

- Procedure 1: Installing the Interface in the PLC Rack - *Required*
- Procedure 2: Verifying Proper Power-Up of the Interface - *Required*
- Procedure 3: Configuring the Interface with the Logicmaster™ 90-70 Configurator - *Required*
- Procedure 4: Configuring and Downloading a Station - *Required*
- Procedure 5: Testing the Interfaces on the Network - *Optional*
- Procedure 6: Using the Example PLC Ladder Program - *Optional*

Some of the procedures require prior cable plant design and installation.

After completing the Installation Procedures you will gain an understanding of the parts of the network and how they fit together. You will also have confidence that your equipment is working properly.

# Ethernet Hardware Overview

The Ethernet Interface consists of a controller board mounted in the Series 90-70 PLC rack. It is connected to an external transceiver via a user-provided transceiver cable. The external transceiver is then connected to the Ethernet cable. The figure below shows the layout of the Ethernet Controller board.

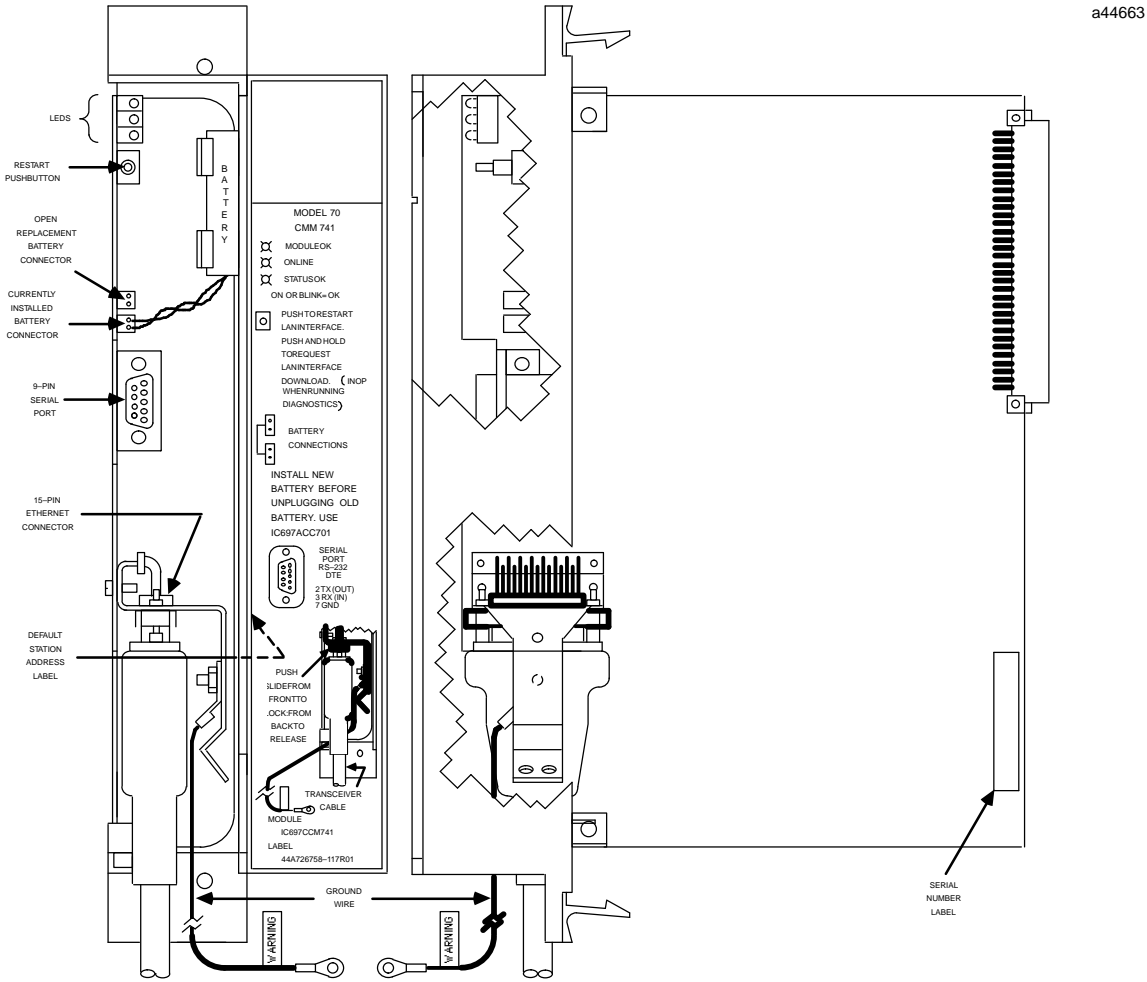

Figure 2-1. Ethernet Controller Board

The Ethernet Controller board has several user-accessible elements.

Three LEDs are located at the top of the board. The Restart pushbutton is located immediately below the LEDs. The battery and battery holder is located to the right of the LEDs. The battery connectors are located on the controller board between the Restart button and the 9-pin connector to the serial port. The 15-pin connector, located beneath the serial port and facing downward, is the transceiver port. The Default Station Address label is affixed on the outside of the plastic housing.

## Board Indicators

There are three LEDs on the Ethernet Controller board. The table below describes the general meaning of each of the LEDs.

**Table 2-1. Ethernet Controller Board Indicators**

Indicator	Status	Description
MODULE OK	ON	MODULE OK is ON if the Ethernet Interface has passed diagnostics and its hardware is operating properly.
	OFF	It is OFF if the module fails a diagnostic test or if a fatal failure is detected while the board is running.
	BLINKING	This LED is blinking if the module is running diagnostics or is in Soft Switch entry state. If this LED and the STATUS OK LED are blinking together, diagnostics have completed and the operator is being given a chance to enter Field Network Test.
ONLINE	ON	ONLINE is ON when the Ethernet Interface is connected to and ready to communicate on the network.
	OFF	This LED is OFF when: <ul style="list-style-type: none"> <li>■ the station is not communicating on the network due to disconnection or a disruption of the cable.</li> <li>■ the local station has malfunctioned or</li> <li>■ the Ethernet Interface has been commanded not to enter the network or is in a state where network operation is inappropriate, such as Soft Switch Entry state or local loading.</li> </ul>
	BLINKING	It is BLINKING when the module is transferring data on the network or loading over the network.
STATUS OK	ON	STATUS OK is ON if the module is running without exception conditions.
	OFF	This LED is OFF if the module is running and detects an event that calls for supervisory attention. In this case you should connect the GSM and follow the instructions in Chapter 9 to obtain further information.
	BLINKING	This LED is BLINKING if the module is loading or looking for a load source for the Ethernet Interface software.

## Restart Button

The Restart button serves two functions: Restart, and Restart and Reload. The Restart button is inaccessible when the door to the Ethernet Interface is closed.

**Restart:** Pressing the Restart button (for fewer than 5 seconds) forces a restart of the Ethernet Interface. The power-up diagnostics run and the software on the module is restarted when the pushbutton is released.

**Restart and Reload:** Pressing and holding the Restart button for 5 seconds or more forces a restart and requests a reload of the Ethernet Interface. When the Restart button is pressed, all LEDs go out. After 5 seconds have elapsed, the STATUS OK LED comes ON, to indicate that the Ethernet Interface will request a reload. After the Restart pushbutton is released, the power-up diagnostics run and the Ethernet Interface requests to be loaded.

## Notes

In either case, any data being transferred by the Ethernet Interface at the time of the Restart will be lost.

The Restart Pushbutton will not be operable during the Ethernet Controller board diagnostic phase. The Ethernet Controller board is in diagnostic phase when the BOARD OK LED is BLINKING and the ONLINE and STATUS OK LEDs are off.

## Battery

When connected, the battery preserves the contents of RAM when there is no power to the board. The battery will maintain RAM contents for a minimum of six months.

### Warning

**The lithium battery presents a fire, explosion, or severe burn risk. Do NOT: recharge it, remove its polarized connector, disassemble it, heat it above 100C (212F), incinerate it, or expose its cell contents to water. Dispose of the battery as required by applicable ordinances or regulations. When replacing the battery, use only Catalog No. IC697ACC701. Use of another battery could result in ignition or explosion of the battery. Replacement batteries can be ordered from GE Fanuc Automation - NA or any GE Fanuc Authorized Distributor.**

## Serial Port

The 9-pin serial port (RS-232 interface) is used to connect to the GEnet System Manager (GSM). The communication software on the distribution diskette may be loaded through this port. A cable is needed to connect the GSM to the Ethernet Interface (see Appendix D, Communications Ports Characteristics). The faceplate of the Interface must be open to connect the cable. The serial port may also be used with a serial terminal for local Station Management.

## AUI (Transceiver) Port

The 15-pin AUI port provides the electrical and mechanical interface to the user-provided IEEE 802.3 transceiver cable, which connects the AUI Port to an external IEEE 802.3-compatible transceiver (see Appendix D for the characteristics of the AUI Port). The external transceiver is directly connected to the Ethernet cable.

## Default Station Address Label

The Default Station Address label lists the default station address to be used by this module, unless changed by the user.

## Serial Number Label

The Serial Number Label indicates the serial number of this controller board.



## Procedure 1: Installing the Ethernet Interface in the PLC

This section describes the physical installation of the Ethernet Controller board into the Series 90-70 PLC rack. For information on the installation procedures for the rack, 90-70 CPU, Power Supply, and other Series 90-70 modules, refer to GFK-0262, *Series 90-70 Programmable Controller Installation and Operation User's Manual*.

### Equipment Required to Perform the Installation Procedures

In addition to the Ethernet Controller board, make sure you have the items listed below before you begin.

- A Series 90-70 PLC rack.
- A Series 90-70 CPU.
- An operating Logicmaster™ 90-70 system (serial, parallel, or network version).
- A Workmaster®, or IBM-compatible personal computer.
- The GENet Ethernet Interface software diskette.
- A copy of the data sheet applicable to your Ethernet Controller board and cable plant.
- A certified IEEE 802.3-compatible transceiver and Ethernet cables.
- A serial cable for the RS-232 connector on the Ethernet Controller board (see Appendix D).

#### Note

The Ethernet Interface requires a power supply that can provide +5 Vdc and +12 Vdc. Use one of the following power supplies:

IC697PWR711  
IC697PWR721  
IC697PWR731

### Ethernet Interface Installation

The Series 90-70 PLC Ethernet Interface installation is summarized here.

1. Read and record the 12-digit default station address (MAC address) from the printed label on the Ethernet Controller board. A Station Configuration Data Form is provided in Appendix I for your convenience in recording the station configuration information.
2. Be sure the Series 90-70 PLC rack power is OFF.
3. Connect the battery to either of the battery connectors on the controller board.
4. Slide the Ethernet Controller into the Series 90-70 PLC slot for which it was configured in the system - normally the first available slot to the right of the CPU, Bus Transmitter Module (BTM), or Bus Receiver Module (BRM).

Press firmly to lock the board in place, but do not force the board. (See Figure 2-2 for PLC rack, and Figure 2-3 for expansion rack layout.)

### Note

The Ethernet Controller board will not operate properly if there are empty slots to the left of the slot you select.

5. Connect the free end of the safety wire (18 inch long green wire attached to the Ethernet Controller board) to the ground lug at the side of the Series 90-70 PLC rack. (See Figure 2-2).

### Warning

**The ground wire must be securely fastened to the chassis of the Series 90-70 PLC rack and the rack must be properly grounded. Failure to do so may cause personal injury.**

6. Connect the transceiver cable into the 15-pin AUI Port of the Ethernet Controller board. Secure the cable with the slide latch mechanism. The other end of the transceiver cable should be connected to an external IEEE 802.3 compatible transceiver which is attached to the Ethernet network. ***SQE must be enabled on the transceiver***
7. Set the CPU Run/Stop switch to STOP.
8. Continue with Procedure 2: Verifying Ethernet Interface Power-Up.

### Ethernet Interface Installed in Series 90-70 PLC Rack

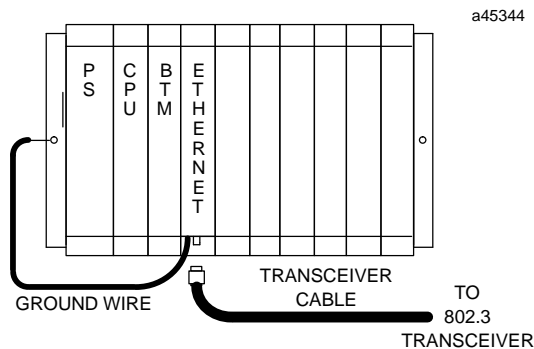

Figure 2-2. Ethernet Controller Installation in the Series 90-70 PLC

## Ethernet Interface Installed in Expansion Racks

Installation of the Ethernet Interface in the expansion racks is shown in Figure 2-3. Expansion racks are connected to the CPU through an 18 twisted-pair cable (called the I/O cable) with one end connected to the lower connector on a Bus Transmitter Module installed in the CPU rack in slot 2, and the other end connected to the top connector on a Bus Receiver Module (BRM) installed in slot 1 in an expansion rack. Each additional rack is then connected in a daisy chain through I/O cables connected to the top and bottom connectors on the BRMs.

The total cable length from the CPU rack to the last expansion rack may be a maximum of 50 feet (15 meters). I/O cables are available in various lengths from 2 to 50 feet (0.6 to 15 meters). Additionally, a single power supply can power two racks (within current limits) when connected by an available cable three feet (1 meter) in length.

The I/O bus in an expanded system must be terminated by installing an I/O bus Terminator plug on the bottom connector of the BRM. This Terminator plug contains a resistor pack configured for proper I/O bus termination. If there are more than two racks in an expansion system, the intermediate expansion racks must not have the Terminator plug installed.

### Note

Install no more than four (4) LAN Interfaces in a single Series 90-70 PLC system.

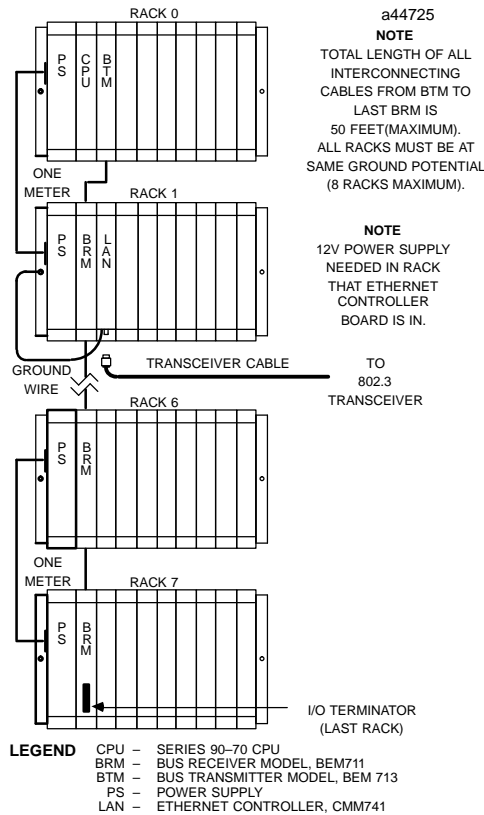

Figure 2-3. Ethernet Interface Installation in an Expansion Rack

## Procedure 2: Verifying Proper Power-Up of the Interface

Before powering-up the Ethernet Interface, you may wish to connect the GEnet System Manager (GSM) *locally* to the Interface, and select the “Station Manager” function from the GSM Main menu. This allows you to observe the progress of the power-up diagnostics via the Station Manager software on the Interface. The GSM is also used to perform other operations in subsequent Installation Procedures.

**Refer to Chapter 3, “The GEnet System Manager”, for instructions on installing the GSM software on a user-supplied PC-compatible computer.**

### Note

Alternatively, you can use a dumb terminal, or another terminal emulation product on a PC. However, you will probably find it most convenient to use the GSM since you will be using the GSM for other configuration purposes in subsequent steps.

If you do not use the GSM, configure the terminal for 9600 bps, 8 bits, no parity, and 1 stop bit. See Appendix D, for instructions on making the serial cable.

## Using the GSM “Access Station Manager” Function

The Station Manager software on the Ethernet Interface is accessed by connecting the LAN Interface to a personal computer running the GSM software and selecting the “Station Manager” function from the GSM main menu.

1. There are two ways the GSM can be physically connected to an Interface: Local Connection and Network Connection.

### Note

To observe the progress of Power-Up Diagnostics described in this procedure and to invoke the Field Network Test Utility described in Installation Procedure 5, the GSM must be connected *locally* and put in the Local Station Manager Communications Mode.

- A. **GSM Using Local Connection.** Connect the COM1 RS-232 serial port on the device running the GSM to the 9-pin connector on the Ethernet Interface. Refer to Appendix D for instructions on how to make the RS-232 cable.
- B. **GSM Using Network Connection.** Connect the Ethernet Interface on the device running the GSM to the Ethernet Network.

For now, use the Local connection.

2. Power-up the computer running the GSM into DOS.

3. Set the PC default directory to the GSM directory, by typing:  
`C:\> cd \gsm`
4. Start-up the GSM by typing:  
`C:\GSM> gsm`
5. At the password screen, type in the password. The default password is "gsm"
6. Once the GSM Main Menu appears, go into the Setup GSM functions to set the Station Manager Communications Mode to Local, exiting with <ALT-U>.
7. From the GSM Main Menu, cursor to the "Station Manager" function and press Enter to select.

If you selected *Local Communications Mode* in step 6, the GSM will automatically access the Station Manager of the locally connected Ethernet Interface. If you are prompted for "Station Name", you did not select Local Station Manager mode. Repeat step 6.

## States of the Ethernet Interface

The figure below shows the 5 possible states of the Ethernet Interface. The states are distinguished by LED patterns and by unique Station Manager NODE command and prompt outputs.

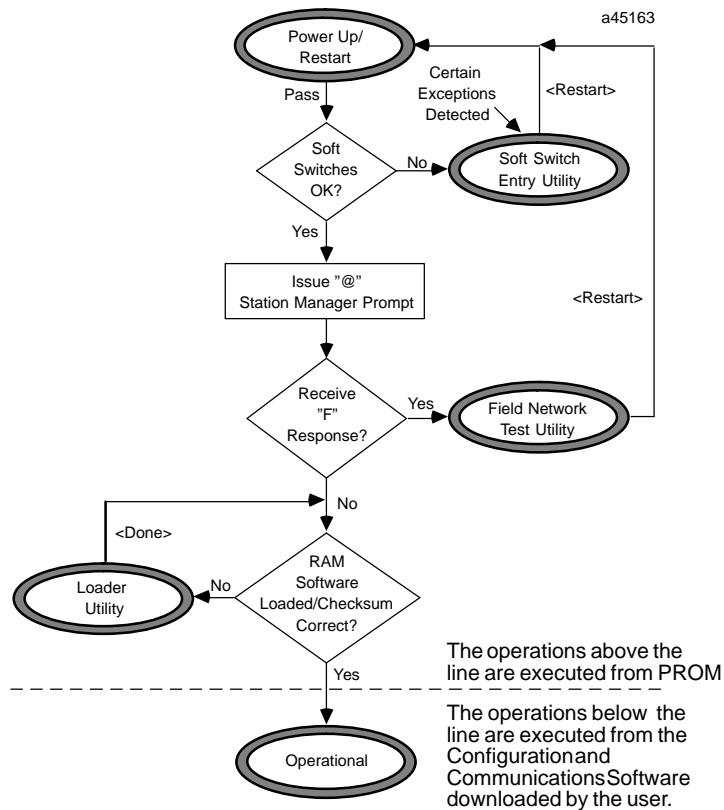

Figure 2-4. States of the Ethernet Interface

The Ethernet Interface will normally transition from the Power-Up State to the Operational State without entering any other state.

If there is a problem with the Soft Switch data, however, the Ethernet Interface will transition automatically to the Soft Switch Entry State (see Appendix E for instructions). And if you have not previously downloaded a station configuration to the Interface, the Interface will transition automatically to the Loader Utility (see Procedures 5 and 6 for instructions). Also, the operator may manually cause the Interface to enter the Field Network Test Utility.

## Powering-Up the Interface

Follow the procedure below to verify that the Interface is operating correctly.

1. Power-up the PLC. This will initiate a series of diagnostic tests.

Upon power-up the *Module OK* LED blinks, *On Line* and *Status OK LEDs* are OFF.

2. Observe the *local* Station Manager screen if connected. If power-up is successful, then a Station Manager message similar to the following will be displayed, normally within 15 seconds.

```
IC697 PLC Factory LAN Interface
Copyright (c) 1990-1994. All rights reserved.
PROM version 1.14, Software version 1.13 MMS/Ethernet
MAC address = <<080019010177>>
Serial no. 01913826, MAC default = <<080019010177>>
```

3. Also, the LEDs will have the following pattern upon successful power up. At this time the Interface is in the Operational State.

LED	Interface On Line
Module OK	ON
On Line	ON
Status OK	ON

# Problems During Power-Up

The Interface may not transition directly to the Operational State upon power-up or restart. It may stop in another state or a fault may have been detected. Refer to the table below for possible states your Ethernet Interface can assume after completion of power-up diagnostics.

LED Pattern	Where Stopped	Possible Cause	Corrective Actions
MODULE OK On STATUS OK Blinking	LoaderUtility	Interface requires a (re)load of communications software.	Load the Communication Software. See Procedure 4.
MODULE OK On ONLINE Off	Operational	Transceiver or transceiver cable not (properly) connected.  SQE not enabled on transceiver.  LAN Online Soft Switch set to NO.	Connect cable & transceiver.  Set SQE ON on transceiver in accord with manufacturer's instructions.  Use LM90 configurator to set LAN Online Soft Switch to "YES". See Procedure 3.
MODULE OK On ONLINE On STATUS OK Off	Operational	Exception condition occurred.	Use the Station Manager LOG command as explained in Chapter 9 under the section, "Troubleshooting When STATUS OK LED is OFF".
MODULE OK Blinking Slowly	Soft Switch Entry Utility	Invalid Soft Switch Data. Soft Switch Data checksum invalid. System Software detected incompatible MAC address assignments. Certain system errors.	Correct Soft Switch Data and Restart or Reload Ethernet Interface. See Procedures 3 and/or 4.
MODULE OK Off	Power-Up/Restart	Fatal Error.	Inspect the Interface for loose components, reseal the Interface, and Restart. Recheck Logicmaster 90 Configuration. Examine PLC Fault Table for clues. If the problem persists, replace the Interface.

---

## ***Procedure 3: Configuring the Ethernet Interface with Logicmaster 90-70 (PLC Module Configuration)***

Before you can use the Ethernet Interface with the Series 90-70 PLC, you must define the Interface to the PLC. This is called *module configuration*. This is done through the Logicmaster™ 90-70 configuration software. The Logicmaster 90-70 configuration software allows you to specify the modules and I/O that will reside in your Series 90-70 PLC rack(s).

Refer to GFK-0263, *Logicmaster 90 Programming Software User's Manual* for configuration information. If you are using the Ethernet version of Logicmaster 90, refer also to GFK-0780, *Logicmaster 90-70 Ethernet User's Manual*.

### **Note**

The Logicmaster 90-70 Configurator is distinct from the GENet System Manager (GSM) Configuration Editor. The Logicmaster 90-70 Configurator defines a module in the Series 90-70 PLC to the PLC CPU. The GSM Configuration Editor defines the Ethernet Interface to other nodes in the network.



## Procedure 4: Configuring and Downloading a Station

For the Ethernet Interface to become a fully *Operational* station, you must perform two GSM operations.

- Create a station configuration file for the Ethernet Interface.
- Download the configuration file to the Ethernet Interface.

Each Interface requires configuration information and communications software in order to operate. The configuration information must be created and stored in a file using the GSM Configuration Editor for that type of interface. This configuration file is downloaded to the Interface along with the communications software. The file is retained on the PC hard disk for a permanent record of the configuration for each Interface in the network.

The configuration information consists largely of timing, buffer, and other parameters which normally assume the default values and are the same for each station on the network. There is, however, other configuration information, such as the Local Application DIB (Directory Information Base), which may be unique for each Ethernet Interface. Configuring a station also associates particular communications software with the MAC address of the station for subsequent downloading (communications software for GE Fanuc CNC Ethernet Interfaces is different from GE Fanuc PLC Ethernet Interfaces). Therefore, a configuration file must be created for each Ethernet Interface.

### Configuring a Station

The configuration procedure is performed offline on a personal computer. It is not explained here, but is found in Chapter 3, “The GENet System Manager” as described below.

- **To install the GSM software on a user-supplied PC Compatible, refer to Chapter 3, Section 1, “Installing and Starting-Up the GSM”.**
- **To configure a station refer to Chapter 3, Section 2, “Configuring a Station”.**

Chapter 3 will explain how to configure a station for a *basic* network. Additional configuration information for more *advanced* networks is provided in Chapter 8, “Tuning and Configuring Stations for an Advanced Network”. The type of parameters you may need to configure include:

- Station Name, Type, and MAC Address (always required)
- ISO Parameters (depending on application)
- MMS Parameters (depending on application)

#### Note

There is a quick way to verify that the Ethernet Interface will transition to the Operational State before you have assembled all the data for configuring the station. To do this you can simply create a configuration file using the GSM default values and then download the station.

## Downloading a Station

The software that handles the Ethernet Interface communication services must be loaded into each Interface on the network. This software is loaded together with the configuration file for each station. The software can be loaded into the Interface through the serial port (locally) or across the network.

### When Must a Station Be Downloaded?

- When the Interface is initially configured.
- When you wish to reload the Interface with new parameters (i.e., configuration was modified).
- When you wish to reload the Interface with a different software version.
- When an Ethernet Interface is replaced for any reason.

### Note

An Ethernet Interface must be configured on the GSM before it can be downloaded by the GSM. See instructions immediately preceding.

### Setting-Up the GSM and the Ethernet Interface for the Download

Start by deciding whether you will load *locally* or over the *network*. Downloading requires a physical connection (communication cable) between the Ethernet Interface and the GSM. This may be either the *local* RS-232 cable (described in Appendix D) or an Ethernet *network* connection.

The Network Download Mode is recommended (if you have an Ethernet Interface installed in the device running the GSM) because the time to download is less than 30 seconds. A download in Local Download Mode takes 5 minutes or more due to the lower data rate of the RS-232 link.

Downloading requires cooperation between the Ethernet Interface and the GSM. *Both* must be in appropriate states, and *both* must be using the same download communication facility, ie, *local* or *network*.

***Before attempting the download make sure you have fulfilled the conditions in the following table.***

### Note

The MAC Address and Load Source Soft Switches of the Ethernet Interface are normally determined by the PLC CPU Configuration, as set in "Procedure 3: Configuring the Ethernet Interface with Logicmaster 90-70 (PLC Module Configuration)".

Feature	GSM	Ethernet Interface
<b>MAC Address</b>	You must configure a station with the <i>MAC Address</i> of the Ethernet Interface you are going to download.	The <i>MAC Address</i> of the station must match the <i>MAC Address</i> of the configuration to be downloaded from the GSM
<b>Download Mode/ Load Source</b>	<p><i>Download Mode</i> The <i>Download Mode</i> must be set so that it is compatible with the physical connection to be used.</p> <p>Set the <i>Download Mode</i> to local or network as appropriate, using the “Setup GSM” function in the GSM Main Menu.</p>	<p><i>Load Source</i> The <i>Load Source</i> Soft Switch parameter must be compatible with the physical connection used to connect to the GSM. The <i>Load Source</i> options are: ALT - Accepts either a local or a network download, wherever it finds the Download Server. Factory Default. LOC - Accepts only a local download. NET - Accepts only a network download.</p>
<b>Loader State</b>	After putting the Ethernet Interface into the <i>Loader State</i> (right column), see instructions immediately below, “Initiating the Download”.	<p>The Ethernet Interface must be in the <i>Loader State</i> to receive a download.</p> <p>a. If the Interface is new from the factory, it will automatically enter the <i>Loader State</i> when powered up. Also, unless overridden by the PLC CPU configuration (set in Procedure 3) the <i>MAC Address</i> will be the default address (shown on a label on the board, see Figure 2-1), and the <i>Load Source</i> will be ALT</p> <p>b. For a previously installed Interface, if you are physically close to it, press and hold the Restart/Load Button on the front of the Interface until the STATUS OK LED comes ON (about 5 seconds).</p> <p>If you are not physically close to the Ethernet Interface and it is not in the <i>Loader State</i>, you can issue the Station Manager <i>LOAD</i> command to the Interface. See the section below entitled “How to Issue the <i>LOAD</i> Command from the Station Manager”.</p>

### Initiating the Download

When the conditions above have been satisfied, initiate the download by selecting the Download Station function from the GSM Main Menu.

#### Local Downloading

If the GSM was in the *Local* Download Mode when you selected Download Station, you will be prompted for the STATION\_NAME of the station to be downloaded. Type in the name and press Enter. (The STATION\_NAME parameter is the name that you assigned to the station when it was initially configured.) Then the download will proceed.

When the local download is complete, the GSM changes automatically to Local Station Manager access. At this time the Ethernet Interface MODULE OK LED should remain ON, and the STATUS OK LED should stop blinking and remain ON. The ONLINE LED should be ON if the station is connected to the Ethernet network. A sign-on message (NODE command output) should appear on the Station Manager screen of the GSM.

## Network Downloading

If the GSM was in the *Network* Download Mode when you selected Download Station, the download will proceed automatically, assuming that the Ethernet Interface is connected to the Ethernet network and is Online.

When the network download is complete, the GSM remains in the Download Server mode waiting for a download request (from any other stations requesting to be downloaded). At this time the Ethernet Interface MODULE OK LED should remain ON, and the STATUS OK LED should stop BLINKING and remain ON, and the ONLINE LED should be ON.

## Problems During the Download

After the download, the Ethernet Interface should transition to the Operational State. This is indicated by the MODULE OK and the STATUS OK LEDs remaining ON. If this is not the case, refer to “Problems During Power-Up” in Procedure 2.

## How to Issue the *LOAD* Command from the Station Manager

If the Ethernet Interface is not already in the *Loader State*, you must place it in the *Loader State* before attempting a download to it. One way to do this is to issue the *LOAD* command to the Interface from the Station Manager as explained below.

1. Go to the Setup GSM functions from the GSM Main Menu and set the Station Manager Mode to “Local” or “Network” depending on how the GSM is connected to the Interface.
2. Select the Access Station Manager function from the GSM Main Menu.
3. If you selected the Local Station Manager mode, skip to step 4.

If you selected the Network Station Manager mode, the Station Name window will appear. Enter the STATION\_NAME of the station you wish to access and press **Enter**. (The STATION\_NAME parameter is the name that was assigned to the station when it was initially configured on the GSM.) NOTE: If the station cannot access the network, you will not receive any response to this command. You will need to correct that problem before proceeding further.

4. Log on to the station. Type “login system” and press **Enter**. (“system” is the default station password). If you are prompted to enter a password, type “system” and press **Enter** again. NOTE: If the station cannot communicate over the link you’re using, you will not receive any response to this command. You will need to correct that problem before proceeding further.
5. Type “load” and press **Enter**. This causes the station to request a load.
6. Press **Esc** to exit the Station Manager and return to the GSM Main Menu. Continue at the preceding section, “Initiating the Download”.

## Procedure 5: Testing the Interfaces on the Network

This procedure shows you how to verify operation of the physical network to provide the necessary foundation for reliable communications.

This procedure will ensure that:

- The cable plant is functional,
- The physical connection of each node is functional,
- All transmission paths meet or exceed the expected low bit error rate.

When you are testing the network, be sure there is an adequate explanation for anything unusual. Logging of exceptions should be the exception, not the rule. Properly setup GENet nodes and networks can run for long periods (weeks or months) without logging exceptions.

### Field Network Test Utility

This section describes the use of the GENet Field Network Test Utility that is built into the Ethernet Interface.

All software and configuration needed to perform these tests is contained in the Interface as it is shipped from the factory. You do not need to download the communications software from the GSM for these tests, however, you may optionally change Soft Switch parameters as described previously. (However, if you have loaded communications software, the Field Network Test Utility will still operate properly, and the software you loaded will be preserved.) The default parameters provided will work on any network with up to 50 nodes. For larger networks, consult GE Fanuc Automation - NA if you need assistance to determine how to test your network.

#### Note

After you have established confidence in your particular application and configuration parameters, you can periodically re-test your physical network *while the application is running*. This is done by using the *TEST* Station Manager command, but without invoking the Field Network Test Utility. All the Station Manager commands available in Field Network Test Utility are also available when the Ethernet Interface is fully operational.

### Invoking the Field Network Test Utility

To invoke the Field Network Test Utility you need to connect the GSM *locally* to one of the Interfaces on the network.

- **Refer to Chapter 3, “The GENet System Manager”, for instructions on installing the GSM software on a user supplied Workmaster or IBM-PC Compatible computer.**
- **See Installation Procedure 2 in this chapter for instructions on using the terminal emulation feature of the GSM.**

## Note

Alternatively, you can use a dumb terminal, or another terminal emulation product on a PC. However, you will probably find it most convenient to use the GSM terminal emulation feature since you will be using the GSM for other configuration purposes. Configure the terminal for 9600 bps, 8 bits, no parity, and 1 stop bit.

Perform the following steps to invoke the *Field Network Test Utility*.

1. Connect the GSM *locally* to one of the Interfaces on the Network you are testing.
2. Power up the PLC (if power is already on, you need to cycle power or press the Restart push-button on the OSI-Ethernet Interface).
3. After step 7 of the power-up diagnostic is complete, the "@" symbol will appear on the terminal device. After the "@" symbol appears, you have 3 seconds to enter the single character ("F" or "f") to invoke the Field Network Test Utility. The "F" will not be echoed back. Any characters other than "f" or "F" are ignored. If you do not see a startup message displayed like the one shown below, press the Restart button on the Ethernet Interface (or cycle power on the station) and repeat this step.

The expected startup message upon entering the Field Network Test Utility is similar to the one shown here:

```
@
IC697 PLC Factory LAN Interface
Copyright (c) 1990-1994. All rights reserved.
PROM Version 1.14 Ethernet
MAC address = <<08001901001f>>
Serial no. 01393790, MAC default = <<08001901001f>>

<<< Field Network Test Utility >>>
$
```

4. Repeat steps 1 through 3 for each Ethernet Interface to be tested.

## Running Field Network Test

Once all stations are running the Field Network Test Utility, you will use the Station Manager to run tests to verify that the cable plant is operating correctly and to examine statistics about network performance.

The procedure below describes the steps to be performed for the Field Network Test.

1. Select a station to be the test initiator and connect the GSM to this station. This may be any GENet LAN Interface (CNC or PLC). If your application uses a particular node to communicate with most others, we suggest you designate this node as the test initiator.

## Note

All commands described in this procedure are issued from your test initiator.

2. Enter the command:

```
$ test all :Lists all nodes on operating network.
```

or

```
$ test 010000000000 :Lists all GE Fanuc nodes on operating network.
```

The response to “test all” will return a list of the MAC addresses of all nodes attached to the network and presently operating. (This list may include other vendor’s nodes since the standard IEEE 802.2 test response mechanism is used. Testing other vendor’s nodes is, however, beyond the scope of this procedure. Ignore responses from these nodes.)

**Caution**

**Using either of the addresses “all” or “010000000000” to access stations on the network is recommended *only* under controlled test conditions. Execution of Station Manager commands on an operational network using these addresses may generate a great deal of traffic and might degrade network or node performance temporarily.**

Compare this list with the nodes in the network. If all expected nodes are not listed, double-check that each node is powered up, is running the Field Network Test Utility, and has its drop cable or transceiver cable connected.

Correct any deficiencies and repeat steps 1 and 2 until all nodes to be tested are in the response list.

This procedure assumes that all stations attached to the network remain either powered or not powered continuously from step 2 through step 6. Turning any node(s) ON or OFF or Restarting any node during this test will artificially inflate the error count.

3. Clear the error log and LLC and MAC tallies in all GE Fanuc *test responder* Interfaces in the test. This step cannot be performed for non-GE Fanuc devices using the Station Manager.

This step can be done for all Interfaces at one time by executing the following *REM*ote commands:

```
$ rem 010000000000 login system :Login to all GE Fanucstations  
$ rem 010000000000 clear log :Clear logs of all GE Fanucstations  
$ rem 010000000000 clear tally :Clear tallies of all GE Fanucstations
```

**Note**

Pressing *Ctrl-R* will display the last command executed. This is especially helpful when you are repeating similar commands. Simply display the previous command, change the desired part of the command, and press Enter.

This step can be done for individual Interfaces by executing the following set of *RE-Mote* commands for *each* Interface to be tested.

```
$ rem <node> login system
$ rem <node> clear log
$ rem <node> clear tally
```

where <node> is the 12-digit MAC address of the target node.

- 4. To clear the error log and LLC and MAC tallies in the *test initiator* Interface, issue the following commands:

```
$ clear log
$ clear tally
```

- 5. Issue the desired *TEST* command to initiate the network test.

```
$ test 010000000000 1000 50 256 :Tests all GE Fanuc stations on the
network
```

or

```
$ test all 1000 50 256 :Tests all stations on the network
```

The *TEST* command causes the test initiator to broadcast 1000 test command frames of varying lengths and data patterns to all GE Fanuc nodes or all nodes of all types on the network. All nodes receiving these commands are expected to send a similar test response back to the initiating node. The initiating node counts all responses from each responding node.

This command will take about 10 minutes to complete. When the command is complete, a report like the following should be displayed.

```
<<< Test Results >>> Page 1 of 1
Command: test <<ffffffffffff>> 3e8H 32H 100H ALT
Init Node: <<08001901001f>> Frames sent: 3e8H Nodes responding: 4H
Responding nodes Response recd Response w/err No Response
<<08001901027d>> 3e8H 0H 0H
<<080019010163>> 3e8H 0H 0H
<<080019010043>> 3e8H 0H 0H
<<08001901012c>> 3e8H 0H 0H
```

This *TEST ALL* command and report shows performance over the network between the initiating node and each responding node, at a rate comparable to what an application might experience. For further information, see the descriptions of the *TEST* and *REPORT* commands in Chapter 4.

Verify that all GENet Interfaces under test are included in the list, either as the initiating node or as a responding node. Also, all GENet Interfaces should report,

- 3e8H Responses received,
- 0H Responses with error, and
- 0H No Responses. (A No Response will occur occasionally. But, on average, a No Response should occur no more than *once* with the *TEST* command above executed with 40,000 frames instead of 1,000 frames.)

Transcribe this report onto a clean copy of the Ethernet Network Test Data Sheet found in Appendix I, Forms. If you are testing a network with many nodes, you may need more than one data sheet.



- 6. When the *TEST ALL* command has completed and its results have been transcribed, gather the accumulated error log and LLC and MAC tallies from all GENet Interfaces by sending the following commands to each station. Transcribe all non-zero results to the Data Sheet.

```
$ rem <node> log
$ rem <node> tally 1
```

- 7. Get the exception log and LLC and MAC tallies from the initiator by issuing the following commands:

```
$ log
$ tally 1
```

Transcribe all non-zero results to the Data Sheet.

The LOG response from each node, including the initiator, should appear as follows:

```
REM$ <<<Exception Log>>>
REM$ Exception log empty
```

Make a notation on the Network Test Data Sheet that the log is empty, or record the values, if any, reported in the log response message.

The TALLY L response from *each* Ethernet Interface should appear as follows:

```
REM> <<< Data Link Tallies >>>
REM> Unreg   = 0000H  Lsap0   = 0000H  LsapOf1  = 0000H  Eth Unreg= 0000H
REM> MacErr  = 0000H  BufProb = 0000H  UnrecPdu = 0000H  TstRcvd  = 0000H
REM> TstResp = 0000H
REM>
REM> <<< MAC Tallies >>>
REM> SQEErr  = 0000H  MisdPack= 0000H  FrameErr = 0000H  SuccOne= 0000H
REM> CrcErr  = 0000H  RbufErr = 0000H  LateColl = 0000H  LostCarr= 0000H
REM> BsyCar  = 0000H  NoRtry  = 0647H  SuccMore = 0000H  FRtry= 0000H
```

The *TALLY L* report provides more detailed information about faults than the *TEST ALL* command. Acceptable tally rates are indicated on the Network Test Data Sheet. Note that certain tallies should always be 0, while other tallies are acceptable if their average rate is not excessive.

Record the *LOG* and *TALLY L* results for each Interface under test.

- 8. At this point, you have completed your initial checkout of the Ethernet Interface and its operation on the network. If the acceptance criteria is met, your Interface and network meets requirements and no further testing is necessary. If the criteria is *not* met, refer to Chapter 9, "Troubleshooting", for the meaning of the log data and refer to Chapter 4, "The Station Manager", for meaning of the tally data.

## Procedure 6. Using the Example PLC Ladder Program

The GENet software diskette contains GSM data files and a Series 90-70 PLC folder for three pre-configured stations. These files are loaded into GENet LAN Interfaces and the Series 90-70 PLCs which contain them to perform various tests between stations. This example program allows the user to:

- Demonstrate that your network is transferring application data.
- Write new ladder programs using the example ladder as a template.

### Loading the Example Station Configurations

If you have not already installed the GSM and Series 90-70 Configuration Editor into the PC, refer to Chapter 3, Section 1, Installing and Starting-Up the GSM, at this time.

Install the Example Stations into the GSM as follows:

1. Set default directory to GSM by typing:

```
C:\> cd\gsm
```

2. With the GSM directory as the default, insert the GENet Ethernet Interface software diskette into the A: drive and type:

```
C:\GSM> a:install d1
```

The *install.bat* file on the diskette will copy the following files to the GSM directory: *stanames.gsm*, *mapdib.gsm*, and *minimap.gsm*. These files create three pre-defined stations *sta1*, *sta2*, and *sta3* in the GSM.

Configuration files for these Example stations are copied into the \GSM\CFILES directory.

If previous versions of the \*.gsm files named above exist in the GSM directory, they are saved as \*.bak prior to copying the pre-defined files.

3. Stations *sta1*, *sta2*, and *sta3* (if desired) must be downloaded to the respective Ethernet Interfaces to establish the proper configuration information data in each node. Refer to Procedure 4, Configuring and Downloading a Station. You need at least 2 test stations: one to initiate requests and one to respond. If desired, you may add a third station to allow multiple associations to a single station.

### Loading the Example PLC Ladder Program

If you have not already installed Logicmaster 90-70 into the PC, do so at this time. Refer to GFK-0263, *Logicmaster 90 Programming Software User's Manual*, when installing the serial or parallel versions of Logicmaster 90-70 software into the PC. Refer to GFK-0780, *Logicmaster 90-70 Ethernet User's Manual*, when installing the Ethernet version of Logicmaster 90-70 software into the PC.

Install the Example Station Ladder into Logicmaster 90-70 as follows:

1. The Example Station ladders are installed into Logicmaster 90-70 as a folder named "mmsv1". Set the PC default directory to the Logicmaster 90-70 drawer (directory) that contains the example ladder folder.

2. With the Logicmaster 90-70 drawer as the default directory, insert the GEnet Ethernet Interface software diskette into the A: drive, and type:

```
C:\LM90> a:install d2
```

The *install.bat* file on the diskette will create the folder subdirectory (if necessary) within the default directory, and then copy the ladder files into the folder subdirectory.

3. The sample folder may need changes, depending upon your hardware:
  - The default configuration assumes a CPU 771 with 256K of memory.
  - The default configuration assumes a certain location of the Ethernet Interface in the Series 90-70 PLC rack.

You should compare the example configuration supplied and make changes with the Logicmaster 90-70 Configurator where needed.

### Note

Keep the Ethernet Interface Status Word (LISW) location at %I1 in order for this demonstration program to work correctly.

Zoom into the slot containing the LAN controller board and change the "Station Address" field to be 080019000001 (for station 1), 080019000002 (for station 2), or 080019000003 (for station 3).

4. The example ladder must be loaded into the Series 90-70 PLC logic memory of stations sta1, sta2, and sta3 (if desired). Refer to GFK-0263, *Logicmaster 90 Programming Software User's Manual* when loading a ladder program into the Series 90-70 PLC.

## Executing the Example PLC Ladder Program

A complete understanding of the Ethernet Interface COMMunication REQuests (COMM\_REQs) is not necessary to execute the example ladder. If you wish to know more details, refer to Chapter 5, "General PLC Application Programming". A printout of the example ladder program is shown in Appendix G, "Ladder Diagram for Network Testing".

The example ladder program contains the following communication requests:

- Initiate Request (in the ASSOC1 program block).
- Read Request (in the RDREG program block).
- Write Request (in the WRTREG program block).

In the example program, the communication parameters for these requests are held in the Block Move (BLKMV\_INT) function blocks. This transfers the parameters to the ap-

appropriate registers. The Block Move function blocks are followed by a single Communication Request (COMM\_REQ) function block. This transfers the communication command from the PLC CPU to the Ethernet Interface.

Before a Read or a Write request to a remote station can be executed, an association must first be established between the local and the remote stations. Once an association has been established, the local station can Read the memory on the remote station, Write a different value to that same memory location on the remote station, then Read the remote station's memory again. The data returned by the two Read requests will be different if the Write request is transferring different data than was already there and the network is correctly passing application data. To perform this procedure, do the following:

1. Invoke the Logicmaster 90-70 Programmer and put the programmer On-Line. Enter 99R on the display line and enter SHIFT-F2 (Reference Tables). This will display part of the Register table, with the cursor pointing to %R99.
2. Enter the rack and slot number of the Ethernet Interface that is to receive the COMM\_REQs. For example, (hexadecimal) 0002 would be rack 0, slot 2 and (hexadecimal) 0103 would be rack 1, slot 3 .
3. Move to %R214. In this register, and the registers that follow, enter the Application Common Name of the remote node with which you wish to communicate.

The possible Application Common Names are "stn1", "stn2", or "stn3".

The register initialization for those names are (all values are hexadecimal):

Register	stn1	stn2	stn3
R214	7473	7473	7473
R215	316E	326E	336E
R216	0	0	0
R217	0	0	0

4. Now press keys SHIFT-F1 (Program Display/Edit) to display the example ladder program on the screen. Make sure the Programmer is in ONLINE mode. First put the CPU into STOP mode, then put the CPU into RUN mode.
5. From the main program block, you will see rungs with a Discrete Internal (%M) reference which turns on a Discrete Output (%Q) point (represented as a nickname). These are the lines that you may toggle (the %M reference) to cause something to happen. Immediately after the toggle line, there is a subprogram block call. When a Discrete Internal point is toggled, the subprogram block on the following rung performs its function. Now toggle %M1 to bring up an association with the application you selected.
6. To check that the association has come up, enter 1I on the display line and enter SHIFT-F2 (Reference Tables). This will display the beginning of the Discrete Input (%I) table. The following bits should be on: %I13 (LAN OK bit in the LISW), %I16 (Ethernet Interface bit in the LISW), and %I17 (Association OK bit in the Association Status Word part of the Association Control Block). Enter SHIFT-F1 to go back to the program display.
7. Now toggle %M3 to issue a Read Request COMM\_REQ. This will attempt to read %R100 on the remote node using a Symbolic Address.
8. Enter 500R and then enter SHIFT-F2 to examine %R500. This contains the value read from the remote node.

9. Now move to %R354. Enter some value different from what is in %R500. This will be the value we write to the remote node. Enter SHIFT-F1 to display the program again.
10. Toggle %M2 to issue a Write Request COMM\_REQ. This will attempt to write the contents of %R354 on the local PLC into %R100 in the remote node using a Symbolic Address.
11. Repeat steps 7 and 8 to see what value was read from the remote node. If the value in %R500 now matches the value in %R354, the two nodes are successfully passing application data.

## What to Do if the Program is Not Working

- If you perform step 6 above and find that not all of the specified bits are on, the association did not come up.
  - If %I16 is off, the Ethernet Interface is not operating.
  - If %I13 is off, there is a problem with the connection to the network.These two problems should be dealt with by consulting Chapter 9, Troubleshooting.
- If the problem in step 6 is that %I17 is off, then the LAN and the Ethernet Interface are operating properly but the COMM\_REQ did not perform its function.
  - Examine %R250. This register should have the hexadecimal value 40, meaning “COMM\_REQ has completed without error”.

If there is some different value there, then the COMM\_REQ was not successfully delivered to the Ethernet Interface.
  - Check %R99 for being an accurate reflection of the rack and slot location of the Ethernet Interface.
- If %R250 contains a hexadecimal 40, then the COMM\_REQ was successfully delivered to the Ethernet Interface.
  - Check %R214 through %R217 for accuracy in specifying the Application Common Name.
  - If the name is correct, make sure that the remote node has been configured, downloaded, and is operating correctly.
- If you continue to have difficulty, contact a GE Fanuc Automation - NA representative for further assistance.

---

## Resuming Normal Operation After Using the Example Program

1. If a previous version of the GSM had been installed before the installation of the example PLC ladder program, enter the following DOS commands:

```
C:\> cd c:\gsm  
C:\GSM> copy *.bak *.gsm
```

This will restore the list of station names and the Directory Information Bases (DIBs) that existed before the example program was installed.

2. Change the default directory to C:\LM90 (the directory where Logicmaster software has been installed).

Use the Logicmaster 90-70 configurator to select the PLC ladder program you plan to use for your application. Then, store this configuration into the Series 90-70 CPU. This step must be performed to restore the application soft switches (in particular, the default station address).

3. Reload the Ethernet Interface from the GSM to get correct DIB information for your application. Making the Ethernet Interface go through diagnostics will also allow it to obtain the latest soft switch information just stored from Logicmaster 90-70 software.

# Chapter 3

## The GENet System Manager-Station Configuration

This chapter describes how to install the GENet System Manager (GSM), and how to use it to configure your GENet LAN Interface. The chapter includes an overview of the GSM and a detailed guide to the basic menus that are used in configuring and managing your GENet Ethernet Interfaces.

The chapter is divided into 5 sections.

Section 1. Installing and Starting-Up the GSM

Section 2. Configuring a Station for a Basic Network

Section 3. Downloading a Station via the GSM

Section 4. Accessing the Station Manager

Section 5. GSM Support Functions

There is additional GSM-related information in Chapter 8, Tuning and Configuring Stations for Advanced Networks.

### Note

The GSM is used to maintain a variety of GENet LAN Interfaces. Parts of this chapter are written so as to reflect this generality. Thus, you may see occasional references to LAN Interfaces other than the type(s) you use.

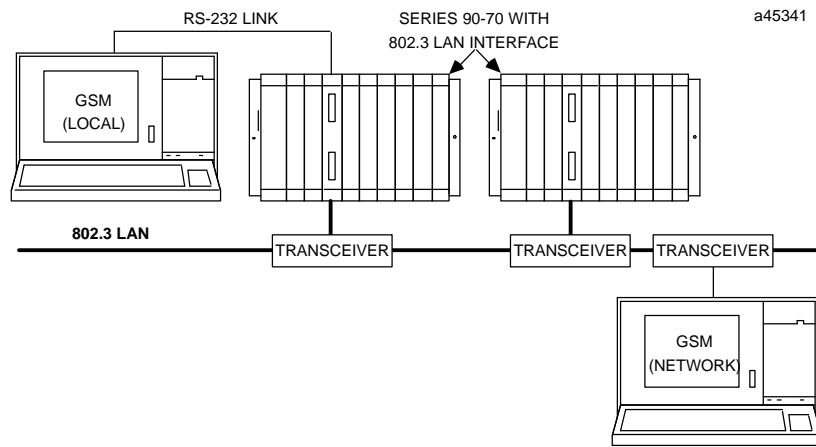

Figure 3-1. GENet System Manager (GSM) on 802.3 LAN

## What is the GSM?

The GEnet™ System Manager (GSM) is a menu-driven software package that runs on a user-provided personal computer (PC). The GSM is used to perform management functions for GEnet LAN Interfaces. The GSM software operates under the MS-DOS® environment.

### The *primary* GSM functions are:

- *Configure Station and Network Parameters*

Access is provided to one or more LAN Interface Configuration Editors. The Configuration Editor is used to examine and modify the configuration information for each GEnet LAN Interface on the network. There is a unique Configuration Editor for each type of LAN Interface. The Configuration Editor is supplied with your LAN Interface Software, and is integrated with the GSM during installation. Station configuration is performed off-line on the PC and results in a configuration file on the hard disk unique to each station.

- *Download the Configuration and Communications Software to the LAN Interface*

This function is used to download initial or revised new configuration parameters or LAN Interface software. The download can occur either over a local serial cable or over the network.

- *Access the Station Manager software on the LAN Interface*

For this function, the GSM becomes a simple terminal emulator that connects to the LAN Interface Station Manager either over a local serial cable or over the network.

### The GSM also provides the following support functions.

- List All Configured Stations
- List all Configured Applications
- Change GSM Password
- Set Download and Station Manager Communication Modes (Local or Network)



## Why Does a Station Have to be Configured and Downloaded?

GEnet Factory LAN Interfaces consist of a circuit board with processor and Ethernet or MAP circuitry, loaded with configuration information and communications software.

The *power-up diagnostics and loader software* reside in Programmable Read Only Memory (PROM) on the board, and cannot be changed without physically disassembling the LAN Interface.

Some very *basic parameters, known as Soft Switch Parameters*, are stored in another kind of memory, Electronically Erasable PROM (EEPROM).

These Soft Switches are set to default values during manufacture of the LAN Interface and are retained indefinitely until changed by the user, normally via the Logicmaster 90 Configurator. For a LAN Interface, the Logicmaster 90 Configurator has access only to these Soft Switch parameters. All other parameters of the LAN Interface are set using the GSM.

The *communications software, along with all other configuration information*, is set and maintained on the GSM, and must be downloaded to the LAN Interface when a software or configuration change is required. This information is stored on the LAN Interface in either battery-backed RAM or Flash Memory. Both these memory technologies permit ready change of the memory content (via downloading from the GSM) but retain their content when power is removed.

## Connecting the GSM to the LAN Interface

The GSM may be carried to the station and connected to the LAN Interface with an RS-232 cable. We refer to this method of connection as local communications mode or local GSM operation.

Alternatively, the GSM can reside at a central location on the network and “logically” connect to any station over the Ethernet network. We refer to this method of connection as network communications mode or network GSM operation.

You must choose which mode of operation you desire.

When using local communications mode, the serial cable is connected between the LAN Interface 9-pin connector and the personal computer COM1 port.

To connect to LAN Interfaces over the network, you must have an appropriate network card for your PC-Compatible computer. See Table 3-1 for a list of supported interfaces.

Figure 3-1 illustrates these alternative connection means of the GSM. The GSM may use either an internal or external modem or transceiver; or none if used exclusively for local operation.

### Note

Typically, there will be only one GSM on the network. It will contain configuration information and communications software for all the GEnet stations on the network.

---

## Section 1. *Installing and Starting-Up the GSM*

This section describes the hardware requirements for running the GENet System Manager (GSM) software, and tells you how to install the GSM on the hard disk of your personal computer.

Topics covered are:

- Hardware Requirements
- Installing the PC Network Interface Card (for Network GSM Operation)
- Installing the GENet System Manager Software
- Setting-Up the DOS System Files
  - For Local GSM Operation (Exclusively)
  - For Network GSM Operation (or both Local and Network)
- Unusual Procedures
- Starting Up the GSM

GENet LAN Interface Software is licensed separately from your GENet LAN Interface hardware. For PLC LAN Interfaces, this software is provided in both 3 1/2-inch and 5 1/4-inch high-density diskette formats; for CNC, 3 1/2-inch high-density diskette format only. The GSM software is part of this GENet LAN Interface Software.

These diskettes **do not** contain the MS-DOS operating system. You must boot your computer from your hard drive or another diskette containing this operating system software.

# Hardware Requirements

The following hardware is required in order to support the GSM software on the PC:

- PC Compatible, DOS Version 5.0 or later.
- RAM: Minimum of 524,288 bytes free (“largest executable program size” on DOS MEM command).
- 2 MBytes of hard disk space.
- 3 1/2 inch high-density diskette drive (for PLC, 5 1/4-inch also supported).
- Color or monochrome monitor.
- *For network GSM operation*, an NDIS-compliant, 802.3/Ethernet card installed in the PC. A list of supported cards is shown in the next section.

## Installing the PC Network Card (for Network GSM Operation)

The table below lists the 802.3/Ethernet cards that GE Fanuc supports for network GSM operation. If you wish to access stations from the GSM across the network, you must have a network card in your PC. The PC network card must support NDIS (Network Driver Interface Specification).

Table 3-1. 802.3/Ethernet Cards for the PC

Vendor	Model	Size	PC Bus	Width
3Com	EtherlinkII™ (3C503)	Halfslot	XT,AT	8-bit
3Com	Etherlink 16™ (3C507)	1 slot	XT,AT	8-bit
3Com	Etherlink/MC™ (3C523)	1 slot	Micro Channel	8-bit
SMC®/Western Digital	EtherCard PLUS™	Halfslot	XT,AT	8-bit
SMC®/Western Digital	EtherCard PLUS Elite 16™	1 slot	AT	16-bit
SMC®/Western Digital	EtherCard PLUS/A™	1 slot	Micro Channel	16-bit
Intel	Intel® 82593	Interface is built-in to Zenith Z-note™ PC		
Xircom	Xircom® Pocket Adapter	External	Enhanced Printer Port	N/A

™ Etherlink II, Etherlink 16, and Etherlink M/C are trademarks of 3Com Corporation.  
 ™ EtherCard PLUS, EtherCard PLUS Elite16, and EtherCard PLUS/A are trademarks of Western Digital Corporation.  
 ™ Z-Note is a trademark of Zenith Data Systems.  
 © Intel is a Registered Trademark of Intel Corporation.  
 © Xircom is a Registered Trademark of Xircom Incorporated.  
 © SMC is a Registered Trademark of Standard Microsystems Corporation.

### Note

The PC can lock-up if you make setup errors when installing PC network cards and device drivers in a PC. Be sure you have a system boot diskette to recover from possible setup errors.

When installing the network card in your PC, be sure to do the following.

1. Install the network card into the computer according to the manufacturer’s instructions. Setup the hardware as described in the table below; these are the default settings of the card. If you do not use the default settings, you will need to record your settings for later use in the section, “Setting-Up DOS Files”.

**Table 3-2. Default PC Hardware Settings for 802.3/Ethernet Cards**

Vendor	Vendor Model [Restriction]	Hardware Settings
3Com	EtherlinkII (3C503)	I/O base address = 0x0300, IRQ3
3Com	Etherlink 16 (3C507)	I/O base address = 0x0300, IRQ3
3Com	Etherlink/MC [ELNKMC.SYS v 2.0 min]	N/A
SMC/Western Digital	EtherCard PLUS	I/O base address = 0x0280, IRQ3, Memory Address = 0D00H
SMC/Western Digital	EtherCard PLUS Elite 16	I/O base address = 0x0280, IRQ3, Memory Address = 0D00H
SMC/Western Digital	EtherCard PLUS/A	I/O base address = 0x0280, IRQ3, Memory Address = 0D00H
Intel	Intel82593	I/O base address = 0x0300, IRQ15,
Xircom	Xircom Pocket Adapter [PE2NDIS.EXE v 1.44 min.]	None

2. Install the device driver software provided with your network card.
3. Run any diagnostic software provided by the manufacturer of the network card to ensure that the card is working properly.

## Installing the GENet System Manager (GSM) Software

To become fully operational, your GENet LAN Interface hardware requires corresponding GENet LAN Interface Software. This software is provided on floppy diskettes.

**For PLC LAN Interfaces** each diskette contains the GSM software as well as the Communications Software and Configuration Editor for your LAN Interface. Select the size of diskette you wish to use.

**For CNC LAN Interfaces** each diskette contains the GSM software as well as the Communications Software and Configuration Editor for one Station Type/LoadType (e.g., Series 15MA, Series 15TT, Series 16MA, etc.). Select the diskette that is compatible with your Station Type/LoadType.

### Caution

**Preserve the original software diskette as a master. Set the diskette write protection to avoid damage to the diskette, copy the diskette, and retain the original as master software. Only working copies should be used for running the software.**

During the installation of the GSM and LAN Interface software, sample DOS system files will be created in the C:\GSM directory. When the software installation is complete, you will need to modify your DOS system files based on the sample files. Refer to the sections on setting-up the DOS system files after you have completed the GSM software installation.

Perform the steps described below to install the GSM software onto your hard disk.

1. Power-up the PC into DOS.
2. Go to the root directory (\) of the drive on which you want to install the GSM. We recommend that you install the GSM on C: because the sample DOS System Files for your PC Interface card are created using C: (see Appendix H).

3. Create a directory for the GSM by typing:

```
C:\> mkdir gsm
```

4. Change the default directory to the GSM directory by typing:

```
C:\> cd gsm
```

### Note

Do not simply copy all of the files from the GSM diskette. Follow the installation procedure.

5. With the GSM directory as the default; place the LAN Interface software diskette into drive A or drive B. If you use drive A, type the instruction below.

```
C:\GSM> a:install
```

If you use drive B, type the instruction below.

```
C:\GSM> b:install
```

The files that make up the Configuration Editor, the Communications Software, and the GSM executable software are now installed in the GSM directory.

6. After the GSM files are installed, the following message will be displayed.

```
Current GSMCFG pathname is : C:\GSM\CFILES
Specify GSMCFG pathname   : _
```

Where GSMCFG is the GSM environment variable which specifies the location of the station configuration files you will later create with the GSM.

The environment variable must be specified in your AUTOEXEC.BAT to take effect. The current step, however, defines it *only* in the AUTOEXEC.GSM sample file in the GSM directory.

It is recommended that you use the default pathname which is C:\GSM\CFILES (when installing on drive C).

To accept the default pathname, press Enter.

### Note

If you ever move your GSM station configuration files, you must redefine the GSMCFG variable in AUTOEXEC.BAT to specify the new location.

7. Next, you will be prompted to specify the type of network card installed in your PC.
  - a. If you are going to use the GSM for local operation only, enter "0" (for no LAN interface installed).
  - b. If you are going to use the GSM for network operation only or for both network and local operation, specify the type of PC network card installed in your PC. Selections in the menu include the PC network card types listed in Table 3-1. Enter the number for the desired PC Network card type and press Enter.

This completes the installation of the software for Network GSM operation. You must now set up the various DOS system files as explained below before the GSM will run properly.

## Setting-Up DOS System Files

After you have completed the GSM software installation procedure, you will need to modify your DOS system files for proper operation of the GSM. Refer to the appropriate section below for setting-up your DOS system files.

### Local GSM Operation (Exclusively)

During the GSM installation for local operation, two sample files were created in the C:\GSM directory. These files are,

```
CONFIG.GSM
AUTOEXEC.GSM
```

These sample files contain the requirements for the files, CONFIG.SYS and AUTOEXEC.BAT, located in the root directory.

1. To set up your PC so the GSM software will run, you *must* ensure that your CONFIG.SYS file and AUTOEXEC.BAT file contain certain commands. The commands needed have been included in the sample files. You may enter these commands individually into your existing CONFIG.SYS and AUTOEXEC.BAT files using an editor, or you may use DOS commands to copy the .GSM files.

CONFIG.GSM

```
FILES = 20
BUFFERS = 48
```

AUTOEXEC.GSM

```
SET GSMCFG=C:\GSM\CFILES
```

(The statement above defines the environment variable GSMCFG. There must be no spaces on either side of the "=" sign.)

2. If installing the GSM software on a PC with a monochrome monitor, add the following command to the AUTOEXEC.BAT file:

```
MODE CO80
```

3. Restart the PC so that the modifications to the AUTOEXEC.BAT and CONFIG.SYS, and will take effect.

### Network GSM Operation (or Both Local and Network)

For network operation, the GSM uses an NDIS-compliant PC network card for connection to the 802.3 network. NDIS-related files will be installed in a C:\GEFNDIS directory created by the install program. NDIS (Network Driver Interface Specification) defines the interconnection between a PC network card and the PC application software (GSM in this case).

During GSM installation for network operation, sample DOS system configuration files will be created in the GSM directory.

These files are,

```
CONFIG.GSM
AUTOEXEC.GSM
PROTOCOL.GSM
```

After installing the software, these files will contain the requirements for the DOS system files, CONFIG.SYS and AUTOEXEC.BAT, located in the root directory and the PROTOCOL.INI file located in the GEFNDIS directory. When the software installation is complete, be sure to look in the .GSM sample files to see the requirements to run the GSM software. Then, refer to the appropriate sub-section below for setting-up the DOS system files.

Before you setup your DOS system files for network operation, you must first determine whether another NDIS network application has already been installed on your computer. To do this, check your CONFIG.SYS file for a PROTMAN.xxx device definition. If this definition is in CONFIG.SYS, then a network application does already exist. In this case, skip the section below and refer to the section, "Adding the GSM When an NDIS Application Already Exists". If you do not find a PROTMAN.xxx device definition in your CONFIG.SYS file, follow just the instructions immediately below.

### When the GSM is the *Only* NDIS Application on the PC

1. To set up your DOS system files so the GSM software will run, you *must* ensure that your CONFIG.SYS file and AUTOEXEC.BAT file contain certain commands. Sample files, showing the commands needed have been created for you during the installation procedure. These sample files are named CONFIG.GSM and AUTOEXEC.GSM and are located in the GSM directory. Sample contents are shown in Appendix H. Note that the content is different for different PC network cards.

Please enter these commands individually into your existing CONFIG.SYS and AUTOEXEC.BAT files using an editor.

If installing the GSM software on a PC with a monochrome monitor, add the following command to the AUTOEXEC.BAT file:

```
MODE CO80
```

2. When you selected the PC network card during the GSM installation, the file, PROTOCOL.GSM, was created. This file contains default information about the communications driver of the PC network card. If you used default hardware settings on your PC network card, you will not have to edit this file. Just copy it to C:\GEFNDIS\PROTOCOL.INI. Otherwise, you must edit any non-default information into the PROTOCOL.GSM and then copy it into C:\GEFNDIS\PROTOCOL.INI.
3. Restart the PC so that the modifications to the AUTOEXEC.BAT, CONFIG.SYS, and PROTOCOL.INI files will be used.

## When an NDIS Application Already Exists

To set DOS system files when an NDIS network application already exists, you need to understand more about how an NDIS application is setup. The following files must be installed for an NDIS application.

PROTMAN.xxx	NDIS Protocol Manager Driver. Extension varies. GE Fanuc uses PROTMAN.DOS
(Network Card Driver)	Provided by PC network card manufacturer. Name varies.
PROTOCOL.INI	File listing each driver and operating parameters for each.

For GE Fanuc applications, the LLC driver, GEFNDIS.DOS, must also be installed. For the GSM, all these files, and some others, are located in the GEFNDIS directory. But, if an NDIS application has been installed previously, other versions of the files described above, except for GEFNDIS.DOS, will already have been placed in another location.

The steps below will explain what to do with these NDIS files to ensure proper network GSM operation.

1. To set up your PC so the GSM software and another NDIS network application can both run, you *must* ensure that your CONFIG.SYS file and AUTOEXEC.BAT file contain certain commands. Sample files showing the commands needed *when the GSM is the only application* have been created for you during the installation procedure. These sample files are named CONFIG.GSM and AUTOEXEC.GSM and are located in the GSM directory. Sample contents are shown in Appendix H. Note that the content is different for different PC network cards.

Since you are adding the GSM when a Network application already exists, some of these commands may already exist, so you will *not* need to add all of these commands. Edit your CONFIG.SYS and AUTOEXEC.BAT as explained below.

2. CONFIG.SYS Include all entries from CONFIG.GSM *except* the following command.

```
device=\gefndis\protman.dos/i:\gefndis
```

This file will already have a valid Protocol Manager (protman.xxx) device definition from the existing network application, and need not be changed. This file will also already have one or more PC network card device definitions from the existing network application. If a valid definition exists for the PC network card selected for the Network GSM, that definition need not be changed.

3. AUTOEXEC.BAT Include the SET GSMCFG command in this file, but *not* the NETBIND command:

```
set cfiles = C:\GSM\CFILES (assuming default directory)
rem Bind NDIS drivers
rem \gefndis\netbind
```

This command is a call to an NDIS driver binding utility. Since an NDIS application already exists, that application must have a call which does the same thing although it may not be obvious by looking at AUTOEXEC.BAT. When the PC is started, binding must occur only once.

If installing the GSM software on a PC with a monochrome monitor, add the following command to the AUTOEXEC.BAT file:

```
MODE CO80
```



4. `PROTOCOL.INI` Do *not* copy `PROTOCOL.GSM` to `PROTOCOL.INI`; the existing network application will already have a `PROTOCOL.INI` file, and you would destroy its contents.

The `PROTOCOL.GSM` file created during GSM installation contains a separate section for defining the operating parameters of each NDIS device: the Protocol Manager driver [`PROTMGR`], the GSM application driver [`GEFNDIS`], and all network card drivers [(name varies)].

The location of the existing `PROTOCOL.INI` file is specified by the “/i” parameter in the Protocol Manager (`protman.xxx`) device specification in the `CONFIG.SYS` file. Make sure the network card driver parameters match the settings for your network card. Refer to Table 3-2 for default settings.

The sample `PROTOCOL.GSM` file shown below is created if you selected the 3Com EtherlinkII network card during software installation.

```
[protocol manager]
  DRIVERNAME = PROTMAN$

[GEFNDIS]
  DRIVERNAME = GEFNDIS$
  BINDINGS = ETHERLINKII
  MAX_RX_SIZE = 560
  NUM_RX_BUFS = 8

; Caution:   Interrupt conflicts may arise when using default hardware
;            configurations for many Ethernet Adapters.  For example,
;            interrupt IRQ3 is commonly used for the COM2 serial port
;            and most Ethernet adapters.
;
; The following information must match the hardware configuration
; of the Ethernet Adapter as installed on your computer.  Please
; modify this information as necessary.

[ETHERLINKII]
  DRIVERNAME = ELNKII$
  DMACHANNEL = 1
  INTERRUPT = 3
  IOADDRESS = 0x300
  MAXTRANSMITS = 8
```

*You must add the device definition sections for **only** the [`GEFNDIS`] device and any new network card [name varies] device from the `PROTOCOL.GSM` file into your existing `PROTOCOL.INI` file.*

5. Restart the PC so that the modifications to the `AUTOEXEC.BAT`, `CONFIG.SYS`, and `PROTOCOL.INI` files will be used.

## Unusual Procedures

### Updating or Adding to Existing GSM Software

Whenever you purchase the GEnet LAN Interface Software, whether for the first time or as an update, you receive all three parts: the Configuration Editor, the Communications Software, and the GSM Software.

Normally, you will install all three parts of this software when you purchase it the first time. If you receive an update, or are adding a new GEnet product, you may install all or part of this software as appropriate. To install a specific part, follow the instructions below.

1. To install *only* the LAN Interface *Configuration Editor*, type:

```
C:\GSM> a:install c
```

2. To install *only* the LAN Interface *Communications Software*, type:

```
C:\GSM> a:install x
```

3. To install *only* the *GSM Software*, type:

```
C:\GSM> a:install g
```

4. To install all 3 components, type:

```
C:\GSM> a:install
```

### Changing the PC Network Card

If you change the PC network card type for any reason, follow the instructions below.

1. Power down the PC. Remove the existing PC network card. Follow the manufacturer's instructions to install the new PC network card.
2. Power up the PC. Change directory to the GSM directory.

```
C:\> cd\gsm
```

3. Run the LANIFSET utility.

```
C:\GSM> lanifset
```

4. This utility accesses the same menu as found in step 7 of the section, "Installing the GEnet System Manager (GSM) Software". Complete the remaining steps of that section.

# Starting-Up the GSM

To start-up the GSM software on the PC, follow steps listed below:

1. Set the default directory to the GSM directory, and then type:

```
C:\GSM> gsm
```

2. Proceed past the copyright notice by pressing any key. The GSM will then prompt you for the main menu password. The default password is "gsm" (lower case). After the correct password has been entered, the GSM will then display its Main Menu. If, instead, you get an error message, you will need to carefully review your installation steps again. Appendix J contains a listing of the GSM Data Link Error Codes.

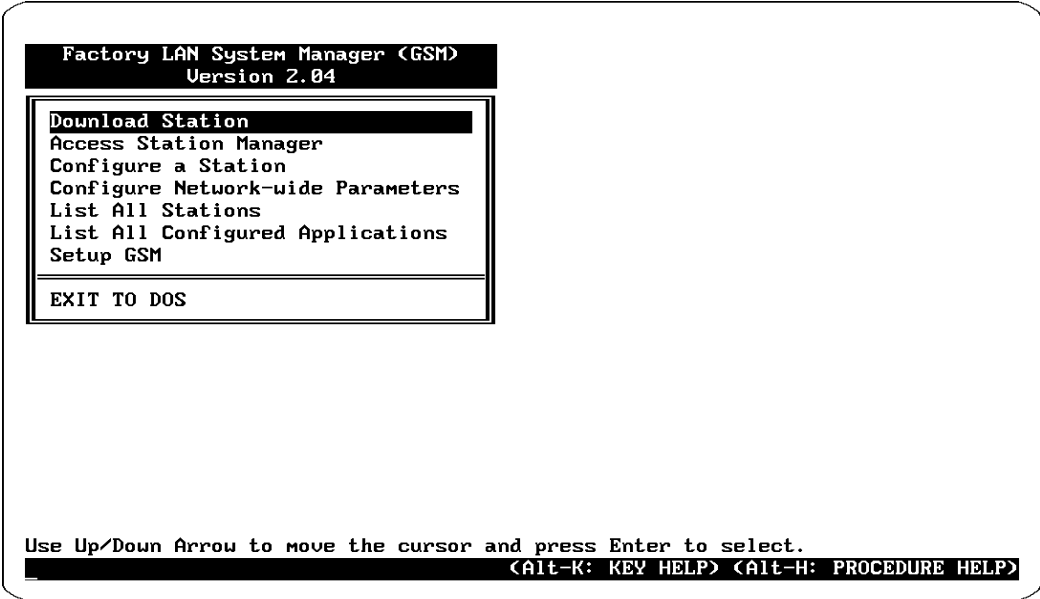

Figure 3-2. GSM Main Menu

The GSM Main Menu lists the functions available in the GSM software. The functions are ordered generally by their frequency of use with the most used function listed first.

Use the Arrow keys to highlight the desired function and press Enter to select. The functions are summarized here, and then described in more detail later in this chapter.

- **Download** communications software and configuration information to the LAN Interface.
- **AccessStationManager** allows the PC to run in a terminal mode of operation for access to the Station Manager residing on a LAN Interface.
- **Configure a Station** provides the means for setting the various parameters of the LAN Interface. The Configuration Editor is a menu-driven software package that is called from the GSM main menu. There is a unique Configuration Editor for each *type* of LAN Interface. For example, there are different Configuration Editors for Series 15 and Series 16 CNCs. The Configuration Editor is used to examine and modify the configuration parameters for a station. These configuration parameters are stored in files on the PC hard disk and subsequently downloaded to the LAN Interface.

- Configure Network-wide Parameters allows a set of system-wide parameters to be set (such as the GSM Loader Multicast Address).
- **List All Stations** displays a list of all LAN interfaces known to this GSM.
- **List all Configured Applications** provides a listing of all Applications that have previously been configured under this GSM.
- **Setup GSM** provides for certain settings affecting the operation of the GSM (such as local or network attachment).

The remainder of this chapter discusses various sub-menus used to configure a LAN Interface for a basic network.

## Working Your Way through the GSM Menus

The GSM is a menu-driven software package that is comprised of a single main menu and a number of sub-menus. Using the PC keyboard, you can move easily through the menus. The GSM uses the PC screen to display its information. Certain areas of the screen are reserved for error, warning, or help messages, while the center is typically used to display the menus.

The GSM uses monitor display lines 1 through 25, with line 1 at the top. The lines display the following type of information:

**Line 1:** displays error messages. For example, if you enter an invalid character in a field, or if the field value is out of range, an error message is displayed on line 1 to indicate the nature of the problem.

**Lines 2-22:** displays the current GSM menu and its related set of fields. For example, there is a Transport Layer menu which is used to display and modify the various parameters that are used by the Transport Layer software.

**Line 23:** displays a help line for the current field that is being examined or modified. This line gives a description of the field, along with the field value ranges, and the field's default value.

**Line 24:** provides instructions for using the screen in general.

**Line 25:** displays important function keys for the current menu. Always present are the keys: Alt-K for Key help and Alt-H for Procedure help.

When a sub-menu is displayed, the parent menu(s) are overlaid by the sub menu. This gives a visual indication of where you are located in the GSM menu hierarchy.

Fields on the GSM screen have a field name and a field value. A sample field name is FIELD\_1\_1. Field entries which are marked by reverse-video are input/display fields. You may modify the data in these fields. A field may require the entry of an alphanumeric, hexadecimal, or decimal value. Fields that display an "\*" require you to press the Tab key to cycle through the possible selections.

For systems which have color graphics hardware, the GSM menus are displayed in color. Selection menus (like the main menu) are displayed as WHITE text on a RED background. Menus with data input/display fields are displayed as WHITE text on a BLUE background.

## GSM Keyboard Functions

The functions of the GSM keys are shown in the table below. In each screen, pressing the Esc key will return you to the previous screen without saving changes.

### Note

If you change the value of a field or fields you must press Alt-U to save the changes. Pressing Alt-U after a field change will also cause you to return to the previous screen.

If you press Esc from a screen in which you have made field changes, those changes will be lost and you will return to the previous screen.

On all screens, pressing Alt-K will display a table describing the special keys used with the GSM. Pressing Alt-H displays a help screen (or a series of help screens) describing how to use the screen that is currently displayed.

**Table 3-3. GSM Keyboard Functions (Alt-K)**

GSM Keyboard Keys	Function
Esc (or F1)	Return to previous menu.
Enter	Accept field contents, move to next field.
← Backspace	Delete character to left of cursor.
Del (Delete)	Delete character.
Alt-A	Abort procedure.
Alt-C	Clear field contents.
Alt-D (or F3)	Delete entry.
Alt-E	Enter Selected Configuration Editor from Configure a Station screen.
Alt-F	If in Station Manager Access, enables logging to a file.
Alt-H	Display procedure help screen.
Alt-K	Display key help.
Alt-L	Display list of stations for selection.
Alt-P	Create printable file. If in Station Manager Access and you have enabled Station Manager logging to a file (Alt-F), Alt-P will close the file.
Alt-U (or F2)	Save current menu data, return to previous menu.
Alt-V	View contents of table entry.
Alt-S	Search for specified table entry.
Tab (or F9)	Cycle forward through field entries.
Shift-Tab (or F10)	Cycle backward through field entries.
Ins	Character insert or replace mode.
↑ (Up Arrow)	Move to previous field.
↓ (Down Arrow)	Move to next field.
→	Move right one character in field.
←	Move left one character in field.
PgUp (Page Up)	Display previous page, or previous entry.
PgDn (Page Down)	Display next page, or next entry.
Home	Display first page, or first entry.
End	Display last page, or last entry.

## GSM Menu Structure

The menu structure of the of the GENet System Manager software is shown below. In this chapter, however, we will address only the screens generally used in the configuration process. not screens used for tuning advanced networks or entering special routing information in advanced networks. The screens marked with an asterisk in the figure below are discussed in Chapter 8, Tuning and Configuring Stations for an Advanced Network.

a45342

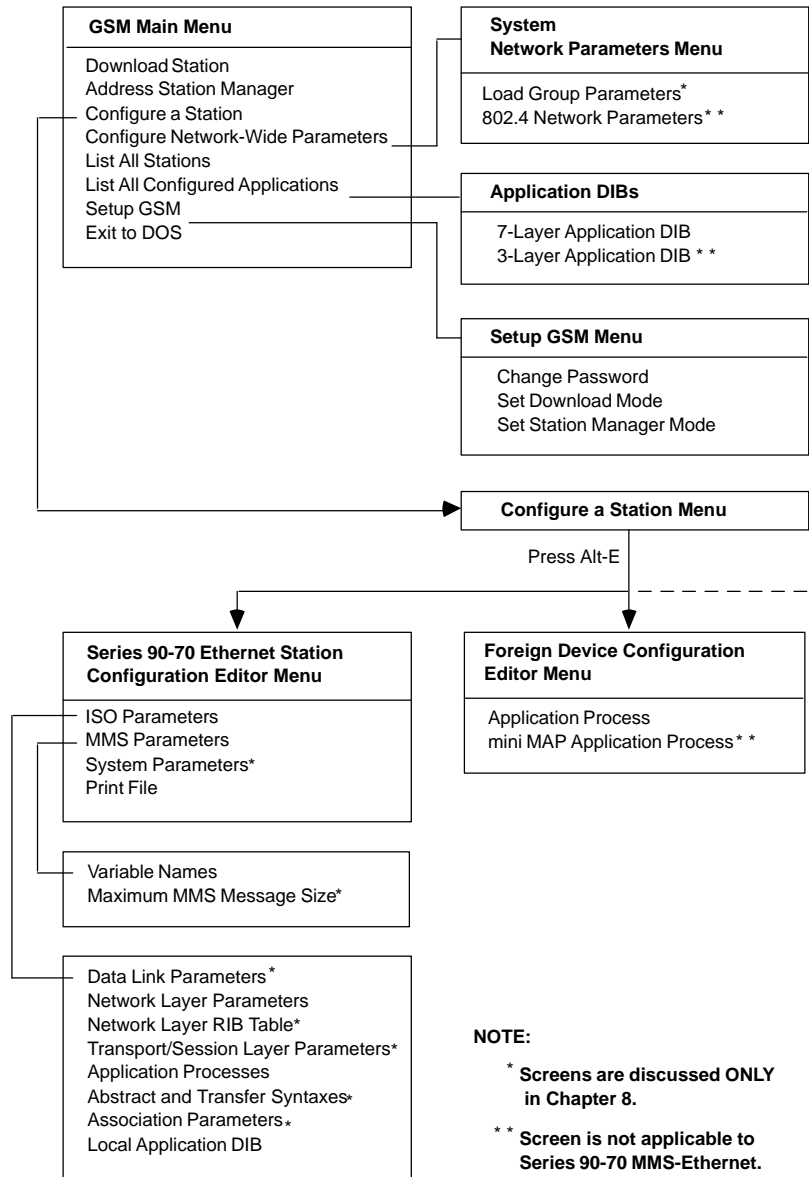

Figure 3-3. GSM Menu Structure

## Section 2. Configuring a Station for a Basic Network

Aside from possibly using the GSM to access the Station Manager for field network testing, the first major GSM operation you will perform in bringing-up your network is configuring a station.

Within the GSM there are various configuration screens. There are screens for configuring stations, for tuning a network for ultimate performance, and for routing communications through network routers.

If your network is a *basic* network as is usually the case, you will need to use only a few of these screens to configure stations. (See definition of a *basic* network below). These basic configuration screens are discussed in this section.

### Note

The configuration screens *not* discussed in this chapter are used for configuring and tuning more *advanced* networks. ***These screens are discussed in detail in Chapter 8, Tuning and Configuring Stations for an Advanced Network.*** Even if you are configuring an advanced network, you may wish to begin with this section and then proceed to Chapter 8 later.

## Definition of a *Basic* Network

A *basic* network is a network in which communications are limited to IEEE 802.3 stations that are interconnected directly or through a repeater or bridge. If a host is part of the network, it supports all standard protocols and default conventions. Also, performance demands on the network are minimal.

## Information Needed to Configure an Ethernet Station for a *Basic* Network

The most important information you will need to know before configuring a station is:

- Station Name
- Station Type
- Station MAC Address (the default MAC address can be found on the label on the backplane connector of the Ethernet Interface).

The remaining configuration information is of 2 main types.

1. ISO Parameters
2. MMS Parameters

### ISO Parameters

- PSAP and SSAP for the application.
- TSAP for the Transport layer.
- NSAP for the Network layer.

This information further defines how communications are routed through the ISO protocol layers to the PLC. We recommend that you use the defaults set by GE Fanuc. Or if it is necessary for you to use settings other than the defaults, you can obtain this information from your network administrator.

### MMS Parameters

- Variables you want to define.

### If Initiating Associations

If the Ethernet station is to initiate associations with other stations, information about the Application Processes for the other station(s) must be made available on this GSM before you can complete the configuration of this station. The essential information about the other station(s) includes,

- Common Name
- PSAP
- SSAP
- TSAP
- NSAP

If the other stations are GE Fanuc stations, then this information will be made available to the GSM after you configure those stations.

If the other stations are *not* GE Fanuc stations, then you will need to gather this information for these stations and supply it to the GSM in the Foreign Device Configuration Screens. It is best to configure the other stations first, then the initiating station.

Once you have gathered the information discussed above, you are ready to proceed to the Configure a Station screen and on to the other applicable configuration screens. The rest of this section describes the screens and fields in which to enter this information.



## Configure a Station Screen

A number of different GENet LAN Interface products may be present on the LAN. Each GENet LAN Interface must be configured using that product's Configuration Editor before it can be downloaded. Before entering the Configuration Editor you must first access the *Configure a Station Screen* from the *GSM Main Menu*.

The Configure a Station Screen allows you to perform 3 main functions.

- Create a Station Configuration File
- Select an Existing Station Configuration File
- Delete a Station Configuration File

The *Configure a Station Screen*, shown below, is used to specify the Station Type and to assign a logical name (STATION\_NAME) to the station. The STATION\_NAME corresponds to the unique MAC\_ADDRESS which physically identifies the station on the network. It is also used to modify certain configuration parameters for a station.

When the Edit configuration keys (Alt-E) are pressed in this menu, the GSM calls the Configuration Editor required for that specific Station Type of GENet Interface.

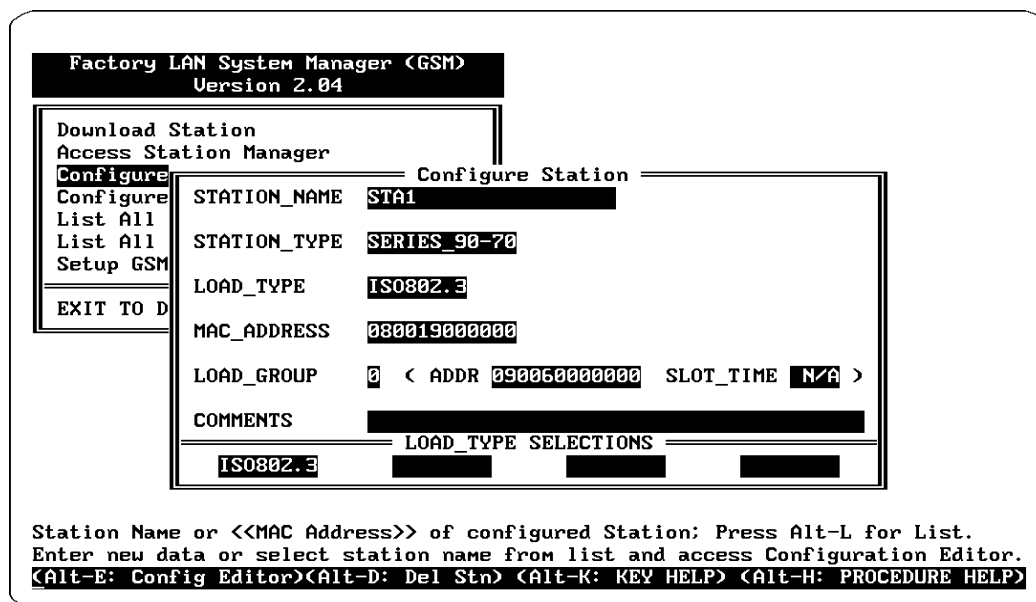

Figure 3-4. Configure a Station Screen

### Note

A form has been provided to assist you in recording Configuration data. Refer to Appendix I, Forms.

## Creating a Station Configuration File

1. Type in or select desired values for the STATION\_NAME, STATION\_TYPE fields, etc. See the description of screen fields below.
2. Press Alt-E to enter the Configuration Editor.

### Field Definitions for the Configure a Station Screen

STATION\_NAME - A name (1 to 20 characters) which is used to uniquely identify the station on the GSM hard disk.

STATION\_TYPE - The type of device containing the LAN Interface.

- The value for this field is selected from a set of choices; press the Tab key to view the choices. The available choices depend on what products have been installed into the GSM system.
- Possible values include: SERIES\_90-70, S\_15\_XX, S\_16\_XX, FOREIGN\_DEV.
  - SERIES\_90-70 is used for the Series 90-70 PLC Interfaces
  - S\_15\_XX and S\_16\_XX are used for the Series 15 and Series 16 CNC OSI-Ethernet Interfaces.
  - FOREIGN\_DEV is used to identify non-GE Fanuc devices. It allows information about non-GE Fanuc devices to be entered into the Application DIBs.

LOAD\_TYPE - The type of station being configured.

MAC\_ADDRESS - The 12 hex digit MAC address of the station being configured. This will be either the Default MAC Address as delivered with your board, or a Locally Administered MAC Address in the case where you have specified the MAC address yourself. See the description on the structure of the MAC Address later in this section.

Each LAN Interface is delivered with a Default Station Address already set. There are several ways to determine this value:

- Look at the label located on the LAN Interface
- Use the Station Manager NODE command.
- Press the Restart button to see the MAC address appear on the Local Station Manager terminal screen (be sure the Station Manager terminal is connected to the Interface).

The Default Station (MAC) Address is a globally administered address; the global administration process assures that each default MAC address is unique. Your organization may have its own scheme of how addresses are administered. In this case you will not use the default address, but will assign a different address from a set of numbers established by your address administrator.

LOAD\_GROUP - The number of the selected download group for the station. The Load Group selects which multicast address is used when loading the station. The multicast addresses and slot times are assigned to the Load Groups via the System Network Parameters menu. Value may be 0 to 4 (default is 0).

COMMENTS - This field is optional, but may be used to insert a comment line up to 40 characters long for the station being configured. These comments will be displayed on the List All Stations Screen.

## Selecting a Station Configuration File

Select a station by filling in the STATION\_NAME field in one of three ways.

- Type in the Station Name, or
- Type in a << MAC Address>> specified as exactly 12 hexadecimal digits within a double set of brackets (for example, <<08001901001d>>). The GSM will convert the MAC address into the corresponding station name, or
- Select a station from a list of stations. Press Alt-L for the list. From this list, you select the desired station, which is then displayed on the *Configure a Station Menu*.

The Up Arrow, Down Arrow, Pg Up, Pg Dn, Home, and End keys may be used to move within the list. You may also begin a search by pressing Alt-S. When the desired station is displayed at the top of the list, press the Enter key to select that station. The selected station name is then displayed on the Configure a Station Screen.

After selecting a station, you may press Alt-E to enter the Configuration Editor.

## Deleting a Station Configuration File

1. Select the station you want to delete. (See description above on Selecting a Station.)
2. Press Alt-D.

## Structure of the MAC Address

The MAC Address is a 12-digit hexadecimal number that identifies the station on the physical network. This 12-digit number is organized as 6 octets, each octet is represented by a pair of hexadecimal digits. A typical default MAC Address is shown below.

Octet	1	2	3	4	5	6
Hex No.	0_8	0_0	1_9	0_0	5_3	1_2

Each octet of the MAC Address is an 8-bit binary number. Thus, the 12-digit hex address is really a 48-bit binary number. The typical MAC Address shown above is represented as a binary number as follows:

Octet	1	2	3	4	5	6						
Hex	0	8	0	0	1	9	0	0	5	3	1	2
Binary	0000	1000	0000	0000	0001	1001	0000	0000	0101	0011	0001	0010

Another characteristic that is important, especially for multi-vendor networks, is the order of address-bit transmission on the physical medium. MAC Addresses are transmitted in ascending octet order, with the least significant bit of each octet transmitted first.

The example above is shown including bit transmission order as follows:

Octet	1		2		3		4		5		6	
Hex	0	8	0	0	1	9	0	0	5	3	1	2
Binary	0000	1000	0000	0000	0001	1001	0000	0000	0101	0011	0001	0010
Bit Order	8765	4321	...9									
											MSB of the MAC	
	LSB of the MAC Address-first bit transmitted										Address-last bit transmitted	

If you assign your own MAC Addresses, there are 2 bits of the 48-bit address that you must set according to the instructions that follow:

- Bit 1 in Octet 1 must always be a 0 to indicate an individual station rather than a Group address.
- Bit 2 in Octet 1 must be a 1 to indicate that the address is locally administered. (In the typical default MAC Address shown above, bit 2 in octet 1 is a 0 indicating that it is a globally administered address).
- All other bits can be set as desired as long as all stations on the network have unique addresses.

An example of a locally administered MAC Address is shown below.

Octet	1		2		3		4		5		6	
Hex	0	2	0	0	0	0	0	0	0	1	0	0
Binary	0000	0010	0000	0000	0000	0000	0000	0000	0000	0001	0000	0000
Bit Order	8765	4321	...9									
											MSB of the	
	LSB of the MAC Address-first bit transmitted										MAC Address-last bit transmitted	

If you must change the Station MAC Address, check with the person administering your network to make sure that you select an address that fits into your local administration scheme.

# Configuration Editor Menu for Series 90-70 PLCs

Once a station has been defined in the Configure a Station Menu, you may proceed to the Configuration Editor Menu (by pressing Alt-E) to define that station's communication parameters in more detail. Or, you can return to this menu at any time in the future to examine or modify these parameters. The screen below is the Configuration Editor for the STATION\_TYPE, SERIES\_90-70 and LOAD\_TYPE, ISO 802.3.

### Note

GEnet System Manager releases prior to 2.04 and Configuration Editors prior to 3.22 have a different menu hierarchy. This manual reflects GSM changes first released in GSM 2.04 and Configuration Editor 3.22.

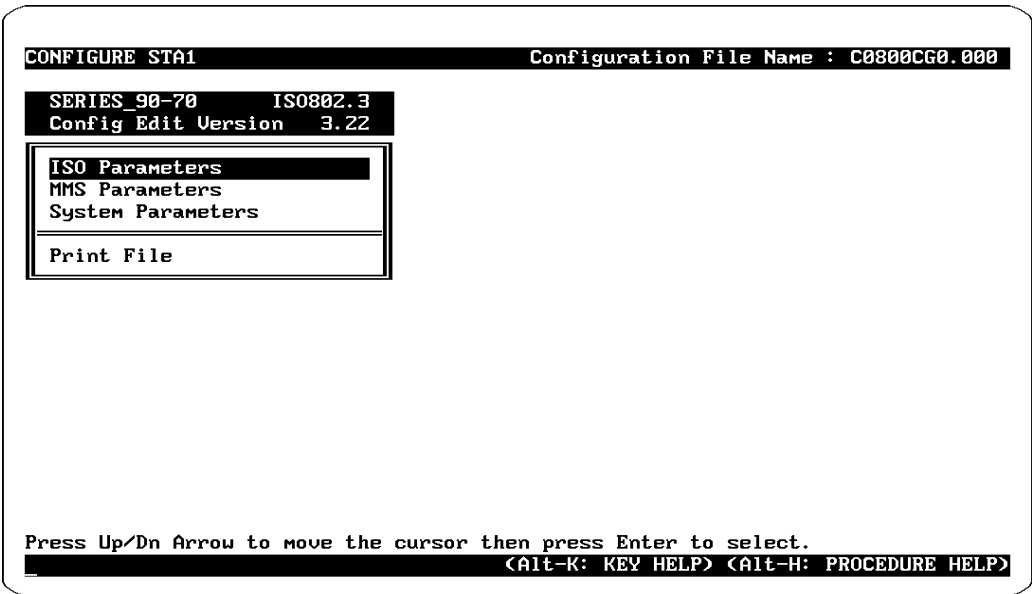

Figure 3-5. Configuration Editor Menu

From this menu, you can access the various sub-menus and screens that allow you to enter or modify parameters values. The parameters have been divided into three main categories: ISO, MMS, and System. Each of these categories may contain sub-categories with corresponding screens.

The **ISO Parameters Menu** selection is used to modify most of the communications parameters. For a basic network, this menu selection is used to examine and modify the parameters for the Link Layer, Network Layer, Transport/SessionLayer, Application Processes, and Local Application DIB (Directory Information Base).

The **MMS Parameters Menu** is used to modify the MMS parameters. For a basic network, this menu selection is used to examine and modify Variable Names, Maximum MMS Message Size, Domains, and Program Invocation, and to list all declared variables.

The **SystemParametersMenu** (not used to configure a station for a basic network) is used to modify parameters which determine how the Ethernet Interface allocates its available buffer memory. This menu is also used to modify the Station Manager parameters and Distributed Directory Protocol parameter. Use of the System Parameters screen is described in Chapter 8.

Finally, the **Print File Menu** is used to name and create a DOS file which contains a copy of the Ethernet Interface configuration.

From this menu, select the appropriate category of parameters you want to configure and press Enter.

## Saving Changes Before Exiting the Configuration Editor Main Menu

The *Configuration Editor Main Menu* is the first screen displayed when entering the Configuration Editor and is the last displayed before exiting the Configuration Editor.

Typically, after you have entered the Configuration Editor, you will go into sub-screens and enter or change values for the parameters included in them. After you have made changes in a sub-screen, you must press Alt-U to save them temporarily while you go to other sub-screens.

After you have finished making changes in the sub-screens and back-out to the Configuration Editor Main Menu, you must press Alt-U *again* to permanently save the changes to disk. If you press Esc to exit the *Configuration Editor Main Menu*, a prompt will appear requesting you to confirm the exit without saving to disk; if you confirm exit, your changes are discarded.

### Note

The first time you create a station configuration, you must enter Alt-U to save the file even if you make no changes to default configuration parameters.

## ISO Parameters Menu

The ISO Parameters Menu lists the communications parameters that may be changed. The ISO Parameters Menu is shown below:

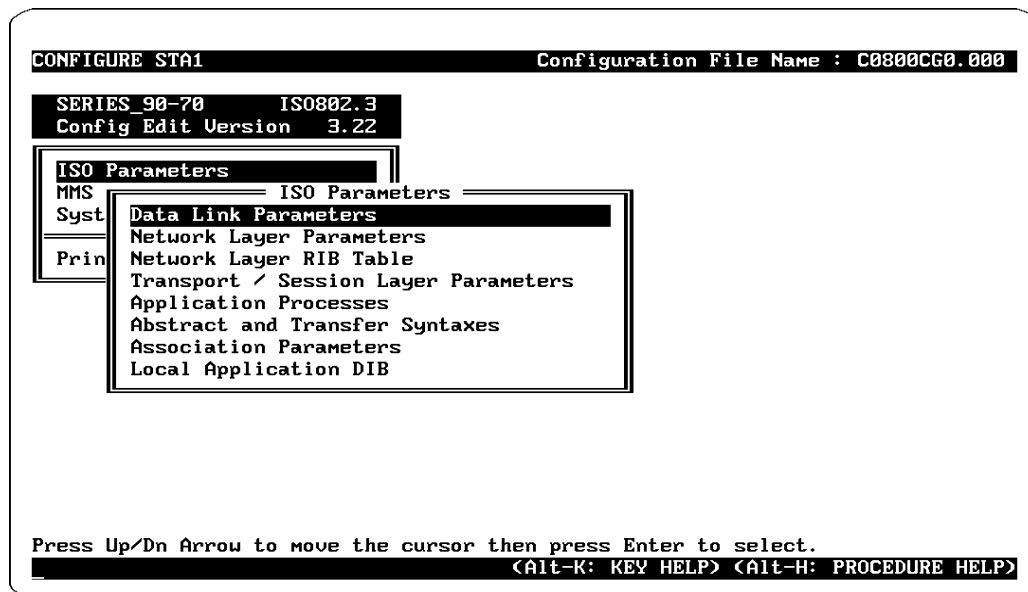

Figure 3-6. ISO Parameters Menu

Each sub-menu is discussed next in the order in which they appear on the ISO Parameters Menu.

For a **basicnetwork** you will only need to use the following screens. (Screens and fields *not* described here are described in Chapter 8, Tuning and Configuring Stations for an Advanced Network.)

- Network Layer Parameters Screen
- Transport/SessionLayerParameters Screen
- ApplicationProcesses Screen
- Local Application DIB (Directory Information Base) Screen

## Network Layer Parameters Screen

The Network Layer Parameters Screen selection is used to modify the Network Layer communications parameters. For a *basicnetwork* the only parameter you need to define is the NSAP (Network Service Access Point). The Network Layer Parameters Screen is shown below:

```

CONFIGURE STA1                               Configuration File Name : C0800CG0.000
SERIES 90-70   IS0802.3
Config Edit Version 3.22

Network Layer Parameters
NSAP 4908001900000001  HEX   LSAP FE HEX
PACKET_PRIORITY 7      MAX_NPDU_SIZE 1497
NPDU_LIFETIME 10      CONFIG_TIME 30      HOLDING_TIME 75
QUERY_WAIT_TIME 45    CHECK_TIME 10      USE_CHECKSUMS N
OPTIMIZE N
ALL_END_SYSTEMS <ES>  MAC_ADDRESS 09002B000004  HEX  LSAP FE  HEX
ALL_INTERMEDIATE_SYSTEMS <IS>  MAC_ADDRESS 09002B000005  HEX  LSAP FE  HEX

Network Service Access Point for this node (hexadecimal)
Edit parameters on screen and press Alt-U to update them.
<Alt-U: Update Parameters>      <Alt-K: KEY HELP> <Alt-H: PROCEDURE HELP>

```

Figure 3-7. Network Layer Parameters Screen

The Network Layer Parameters are defined as follows:

Enter the Station NSAP in the NSAP field and press Alt-U to update.

NSAP - The Network Service Access Point for this node. Entered as a hexadecimal string of octets. Defaults to the combination of the station MAC Address and LSAP. Corresponds to Station Manager Parameter *nsap*.

The remaining parameters need not be modified for basic networks. Refer to Chapter 8 for descriptions of other parameters.



# Transport / Session Layer Parameters Screen

The Transport / Session Layer Parameters Screen selection allows you to modify the Transport and Session Layers communications parameters. For a *basicnetwork* the only parameter you need to define is the TSAP (Transport Service Access Point).

The Transport and Session Layer Parameters Screen is shown below:

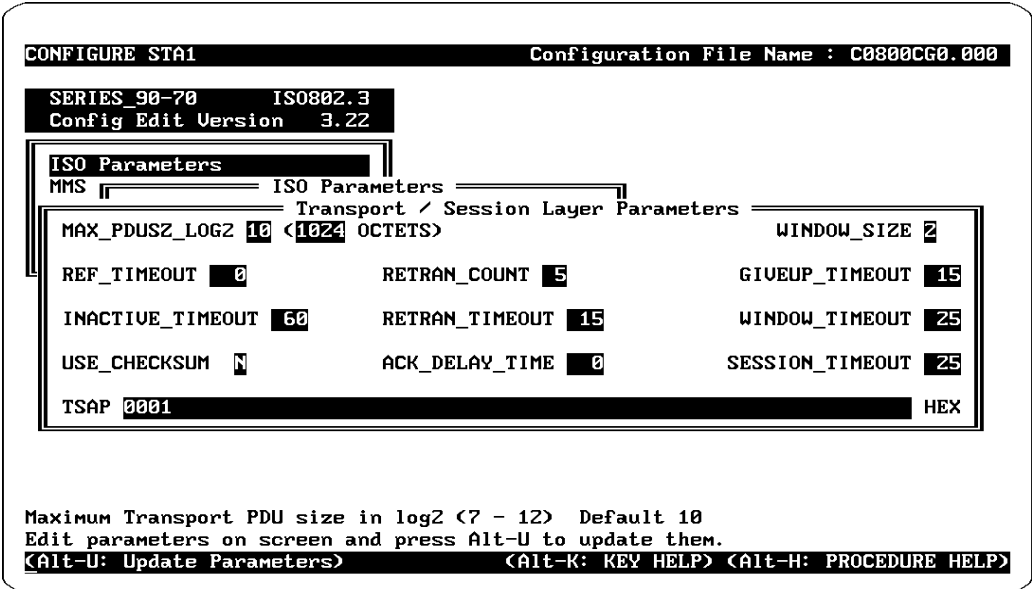

Figure 3-8. Transport/Session Layer Parameters Screen

## Transport Layer: The Transport Layer parameter definitions are:

Enter the Station TSAP in the TSAP field and press Alt-U to update.

TSAP - The ISO Transport Service Access Point to be used for communications services.

Entered as a string of hexadecimal octets. Defaults to 0001 (hex). Corresponds to Station Manager Parameter *stsap*.

The remaining parameters need not be modified for basic networks. Refer to Chapter 8 for descriptions of other parameters.

## Application Processes Screen

The Application Processes Screen selection is used to examine and modify the names of the Ethernet Interface Application Processes, along with certain addressing information. The different communication services are accessed by establishing an association with the appropriate Ethernet Interface Application Process. Each application has a default name assigned to it, but you may reassign these names.

Devices establishing connections to these applications will need the addressing information shown on this screen in order to properly set up connections to one of these applications. Depending on your network configuration, this information will either be entered directly into the other device, or will be available through a directory server on your network.

For a *basicnetwork* if you are not using the default parameters, the only information you need to enter is

- MMS RESPONDER - Common Name, PSAP, SSAP
- APPLICATION\_INTERFACE - Common Name, PSAP, SSAP

The Application Processes screen is shown below:

```

CONFIGURE STA1                               Configuration File Name : C0800CG0.000
SERIES_90-70    IS0802.3
Config Edit Version  3.22

Application Processes
>MMS_RESPONDER
COMMON_NAME RESP080019000000
APT_OBJ_ID C [ ]
AE_QUAL 0 PSAP 00000001 HEX SSAP 0001 HEX
>APPLICATION_INTERFACE
COMMON_NAME APPL080019000000
APT_OBJ_ID C [ ]
AE_QUAL 0 PSAP 00000002 HEX SSAP 0001 HEX
>MMS
ACN ISO MMS
ACN_OBJ_ID C 1 0 9506 2 3 }
>ALTERNATE_MMS
ACN ISO MMS1
ACN_OBJ_ID C [ ]

Application Common Name (1 - 64 characters)
Edit parameters on screen and press Alt-U to update them.
<Alt-U: Update Parameters> <Alt-K: KEY HELP> <Alt-H: PROCEDURE HELP>

```

Figure 3-9. Application Processes Screen

The Application Processes parameters are defined as follows:

COMMON\_NAME - The Common Name of the Application Process. Each Common Name should be unique on the network. Consists of 1 to 64 characters.

- For MMS RESPONDER - defaults to "RESP" + MAC\_ADDRESS. For MMS RESPONDER - corresponds to Station Manager Parameter *arespcnam*.
- For APPLICATION\_INTERFACE - defaults to "APPL" + MAC\_ADDRESS. For APPLICATION\_INTERFACE - corresponds to Station Manager Parameter *applcnam*.

---

PSAP - The Presentation Service Access Point (PSAP) of the Application Process. Each PSAP within a given station must be unique. Entered as a string of hexadecimal octets.

- For MMS RESPONDER - defaults to 01 (hexadecimal). For MMS RESPONDER - corresponds to Station Manager Parameter *aresppsap*.
- For APPLICATION\_INTERFACE - defaults to 02 (hexadecimal). For APPLICATION\_INTERFACE - corresponds to Station Manager Parameter *applpsap*.

SSAP - The Session Service Access Point (SSAP) of the Application Process. Each SSAP within a given station must be unique. Entered as a string of hexadecimal octets.

- For MMS RESPONDER - defaults to 01 (hexadecimal). For MMS RESPONDER - corresponds to Station Manager Parameter *arespsap*.
- For APPLICATION\_INTERFACE - defaults to 02 (hexadecimal). For APPLICATION\_INTERFACE - corresponds to Station Manager Parameter *applssap*.

The remaining parameters need not be modified for basic networks. Refer to Chapter 8 for descriptions of other parameters.

## Local Application DIB Screen

The Local Application DIB (Directory Information Base) Screen , shown below, permits you to select Application Processes for inclusion in the Local Application DIB. You must include applications here to which the PLC will be initiating associations.

The Local Application DIB Screen is shown below:

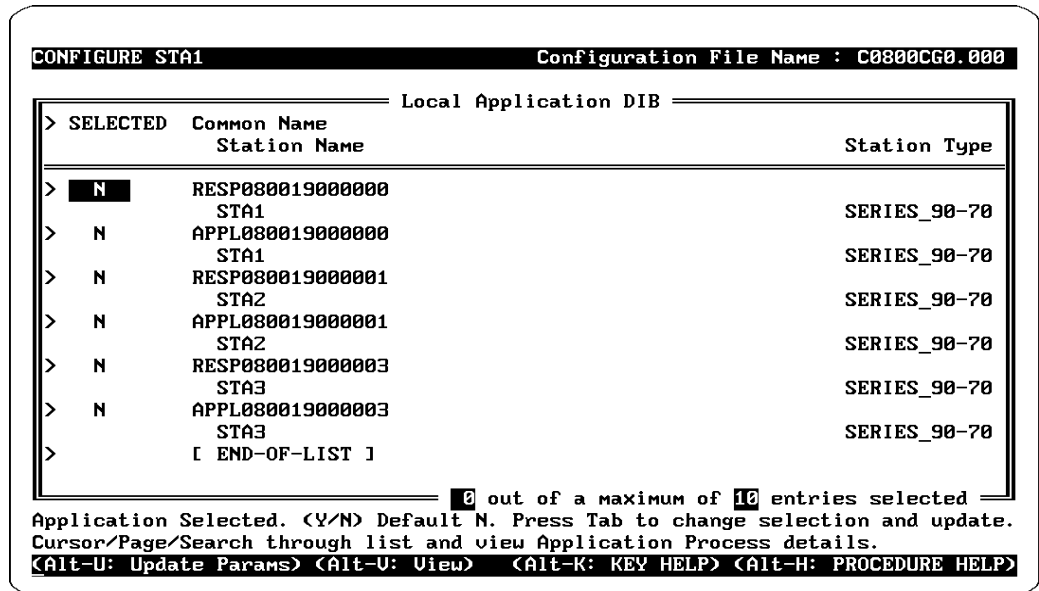

Figure 3-10. Local Application DIB Screen

This screen has the same basic format as the GENet System Manager 7-Layer Application DIB screen. Information is placed into the 7-Layer Application DIB when an Application Process (Common Name) is defined when configuring a station. The Local Application DIB Screen displays a list of all 7-Layer Application DIB entries that have been defined. The Local Application DIB may be examined using the Up Arrow, Down Arrow, PgUp, PgDn, Home, and End keys.

SELECTED - specifies whether that 7-Layer Application DIB entry has been selected for inclusion in the Local Application DIB. Valid values are "Y" and "N". Defaults to "N". Value toggled by the Tab and Shift-Tab keys

The details about a specific DIB entry can be examined by pressing the Alt-V key. When the Alt-V key is pressed, the operator is prompted for which DIB entry to examine. If no COMMON\_NAME is entered, the top entry in the list is displayed.

The Alt-S key is used to search the DIB for a specific entry. When the Alt-S key is pressed, the user selects the data field and a value to seek and selects the search direction. The Alt-S key is pressed again to initiate the search, or the Esc key is pressed to abort the search.

The remaining parameters need not be modified for basic networks. Refer to Chapter 8 for descriptions of other parameters.

## MMS Parameters Menu

The MMS Parameters Menu selection is used to modify the MMS parameters. The MMS Parameters Menu is shown below:

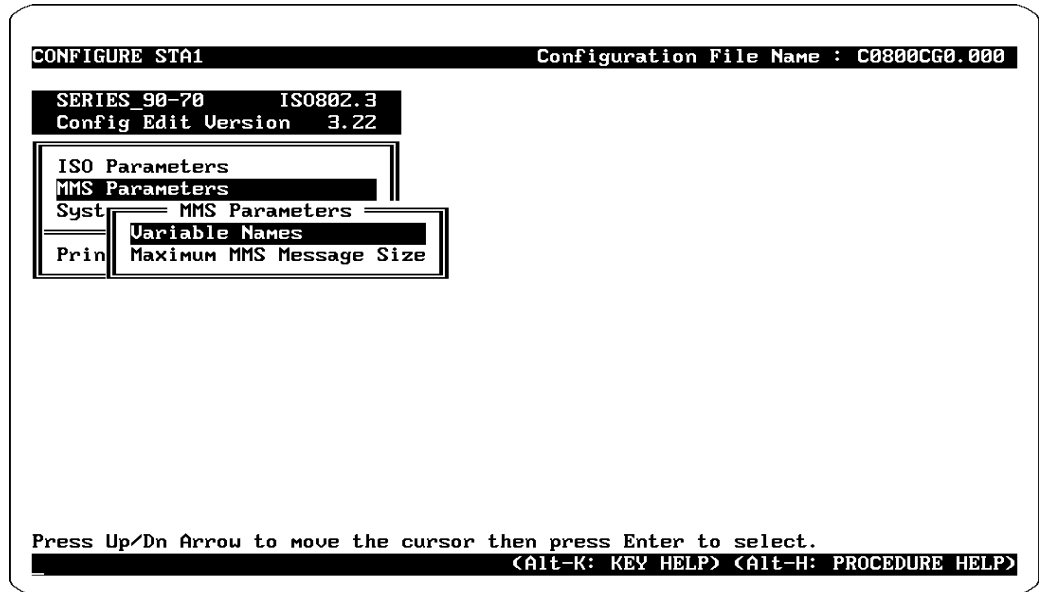

Figure 3-11. MMS Parameters Menu

This menu selection is used to examine and modify:

- Variable Names
- Maximum MMS Message Size

The sub-menus are described below.

## Variable Names Screen

The Variable Names Screen selection is used to modify the Variable Name Table used by the Ethernet Interface. In order to make applications simpler, data in the Series 90-70 PLC can be accessed through a symbolic name, called a Variable Name. The names defined in this menu are in the Virtual Manufacturing Device (VMD) Specific scope of MMS. This means that the names are available without regard to what program is executing in the Series 90-70 PLC.

The Variable Names Screen is shown below:

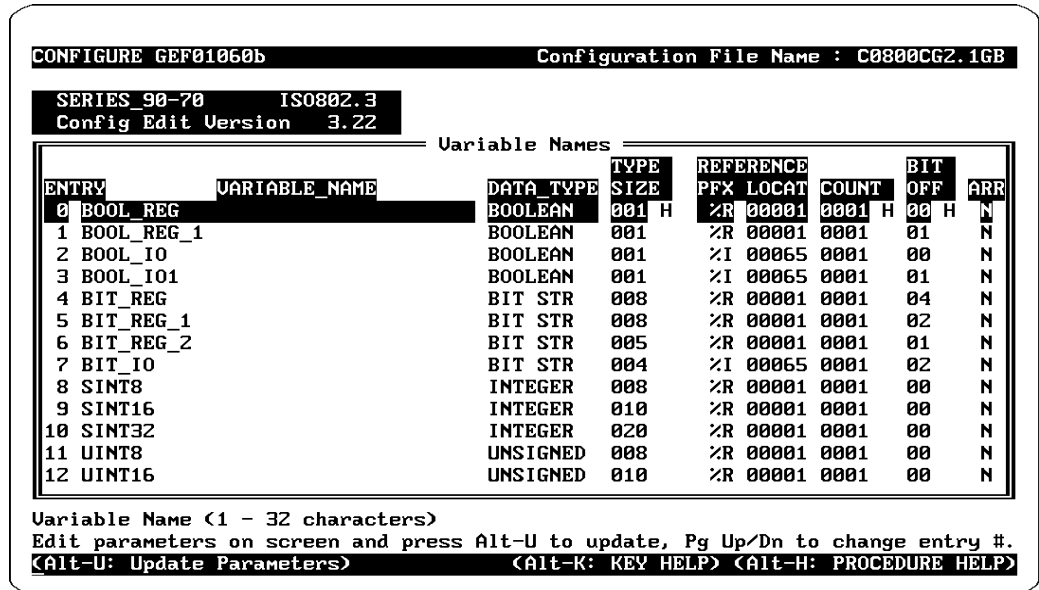

Figure 3-12. Variable Names Screen

The PgUp and PgDn keys are used to scroll through the Variable Name entries.

The Variable Names Parameters are defined as follows:

**ENTRY** - Each entry contains a variable which defines a specific range of addresses in Series 90-70 PLC memory. Remote applications can then access specific memory locations by referencing these variable names in Read or Write requests. The Variable Name table holds up to 64 variables.

**VARIABLE\_NAME** - The defined variable name. Consists of 1 to 32 characters.

**DATA\_TYPE** - The type of data specified by the variable name. Tab and Shift-Tab keys scroll between the choices. Value is one of:

- Character string (CHAR STR)
- Octet string (OCTET STR)
- Floating point (FLOAT PT)
- Unsigned integer (UNSIGNED)
- Integer (INTEGER)
- Bit string (BIT STR)
- Boolean (BOOLEAN)

**TYPE\_SIZE** - The number of octets or bits in the data type. Valid range of 1 to 800 (hexadecimal). Entered as a hexadecimal number.

- For OCTET STR or CHAR STR, specifies the number of OCTETS in the variable or variable array element
- For BIT STR, BOOLEAN, UNSIGNED, or INTEGER, the specifies the number of BITS in the variable or in the variable array element
- For FLOAT PT, only the value 4 should be used

**REFERENCE** - The memory reference within the Series 90-70 PLC. Table 6-16 shows the possible values for the reference address.

**COUNT** - The number of variable array elements. Entered as a hexadecimal number. Valid range 1 to FFFF (hexadecimal). For variables which are not arrays (i.e. scalars) this field should be set to 1.

**BIT OFF** - The bit offset relative to the starting address of this variable. Entered as a hexadecimal number. Valid range of 00 to 0F (hexadecimal). Used only if the Data Type specifies a BIT STR or BOOLEAN data type; for all other data types, it must be 00.

**ARR** - Specifies if the variable is an array or a scalar variable. Valid values of "Y" or "N". "Y" specifies that the variable is an array, "N" specifies that the variable is a scalar. Defaults to "N". Value toggled by the Tab or Shift-Tab keys.

### Note

The subject Configuration file must have been saved to disk (by pressing ALT-U from the Configuration Editor Main Menu) before you can print it.

## Print File Screen

The Print File Screen selection is used to create a file which contains a copy of the Ethernet Interface's configuration. By default, the file created can be printed using DOS commands to produce a hard copy of the configuration. The print file will be saved in the C:\GSM\CFILES directory.

The Create Print File Screen is shown below:

```

CONFIGURE STA1 Configuration File Name : C0800CG0.000
SERIES_90-70 IS0802.3
Config Edit Version 3.22
ISO Parameters
MMS Parameters
System Parameters
Print File

Create Print File
PRINT_FILE_NAME P0800CG0.000

Name of file to store print data Default: Pxxxxxx.xxx in config directory
Edit parameter on screen and press Alt-P to create print file.
<Alt-P: Create Print File> <Alt-K: KEY HELP> <Alt-H: PROCEDURE HELP>

```

Figure 3-13. Print File Screen

The Print File Screen Parameter is defined as follows:

**PRINT\_FILE\_NAME** - the name of the file to be created. Consists of 1 to 14 characters. Defaults to Pxxxxxxx.xxx where xxxxxxxx.xxx is an ASCII encoding of the station's 48-bit MAC address. May reference another disk drive, (for example, A:WC47.LIS).

There are two ways to exit this screen and return to the Configuration Editor Main Menu:

- Esc key - exit without creating a file.
- Alt-P key - causes the print file to be created and stored on the disk, then exits.



---

## Configuring a Non-GE Fanuc Device

In order for Ethernet Interface applications to initiate communications with a non-GE Fanuc, directory information about the remote application must be available. You must supply this information in the Foreign Device Application Processes screen, and then select the desired application processes from the Local Application DIBs (Directory Information Bases) of the Ethernet station.

An Application Process is added to the Local Application DIB by selecting it from the 7-Layer Application DIB database. The Configuration Editor Local Application DIB screen is used to do this. Entries are placed in the 7-Layer Application DIB database when a station is configured. In order to select an entry for the Local DIB, the station which contains this Application Process must first be configured.

If this station is *not* a GE Fanuc Ethernet Interface, the Station Type must first be defined as a Foreign Device in the Configure a Station Screen.

## Foreign Device Configuration Editor Menu

To access the Foreign Device Configuration Editor Menu,

1. Select the GSM Configure Station Screen from the GSM Main Menu.
2. Enter a Station Name for the Foreign Device.
3. Select FOREIGN\_DEV as the STATION\_TYPE.
4. Enter the station MAC Address and comments if desired.
5. Press the Alt-E key.

The Foreign Device Configuration Editor Menu will be displayed.

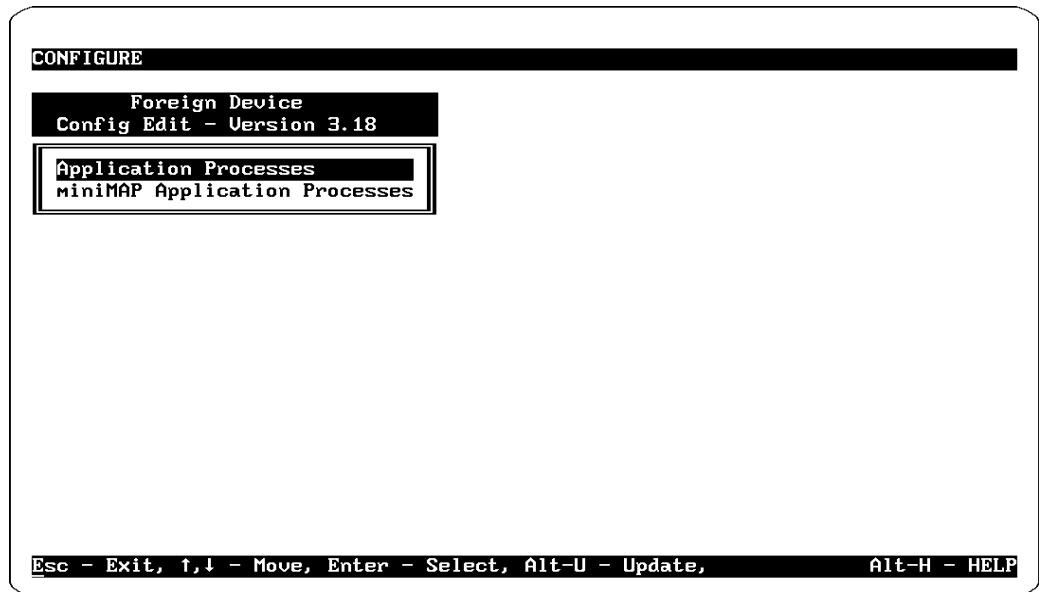

Figure 3-14. Foreign Device Configuration Editor Menu

# Foreign Application Processes Screen

To define Application Processes for a Foreign station select “ApplicationProcesses” from the Foreign Device Configuration Editor Menu. The screen below will appear. This screen allows you to place Application Process definitions in the 7-Layer Application DIBs shown below.

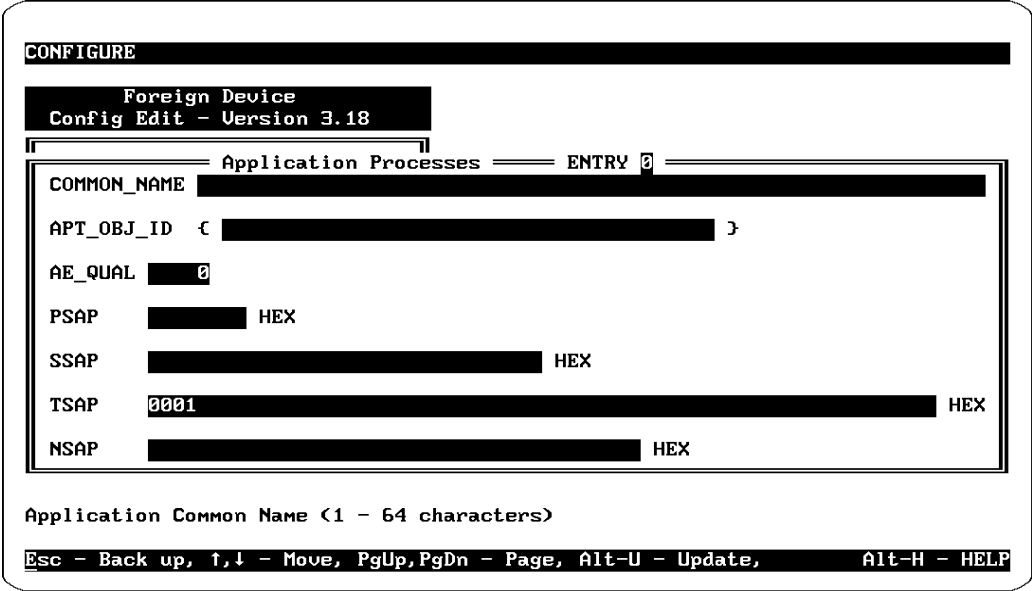

Figure 3-15. Foreign Application Processes Screen

Ten Application Processes may be defined for the station. The PgUp and PgDn keys are used to page through the Application Processes entries.

**The Application Processes Parameters are defined as follows:**

COMMON\_NAME – The Application Common name (1–64 char). The COMMON\_NAME is referenced by the PLC ladder program when using the Initiate Request command.

APT\_OBJ\_ID – The Application Process Title Object Identifier. This field is optional and may be left blank. It is defined as an object identifier. It is a sequence of decimal numeric values.

AE\_QUAL – The Application Process Application Entity (AE) Qualifier (0–65535). It defaults to 0.

The next four parameters are all Application Process Service Access Points (SAPs). They are all entered as a string of hexadecimal octets.

- PSAP – Presentation Service Access Point
- SSAP – Session Service Access Point
- TSAP – Transport Service Access Point
- NSAP – Network Service Access Point

### Note

The Foreign Device Configuration Editor must also be exited using the Alt-U key for the entries to be placed or updated in the 7-Layer Application DIB.

Once entries have been entered in the 7-Layer Application DIB, they can be selected for inclusion in the Local Application DIB of a GENet Ethernet Interface.

## Section 3. Downloading a Station

This section describes only the activities at the GSM associated with downloading a station. For a complete procedure on downloading communication software and configuration information to a station, see Chapter 2, Procedure 4.

### Download Station Screen

The Download Station screen provides a means to download LAN Interfaces via local serial port or the network (depending on selection in the System Network Parameters Menu). After a configuration file has been created and saved, the communication software and configuration file must be loaded into the desired station. The GSM Downloader Screen is used to load the station.

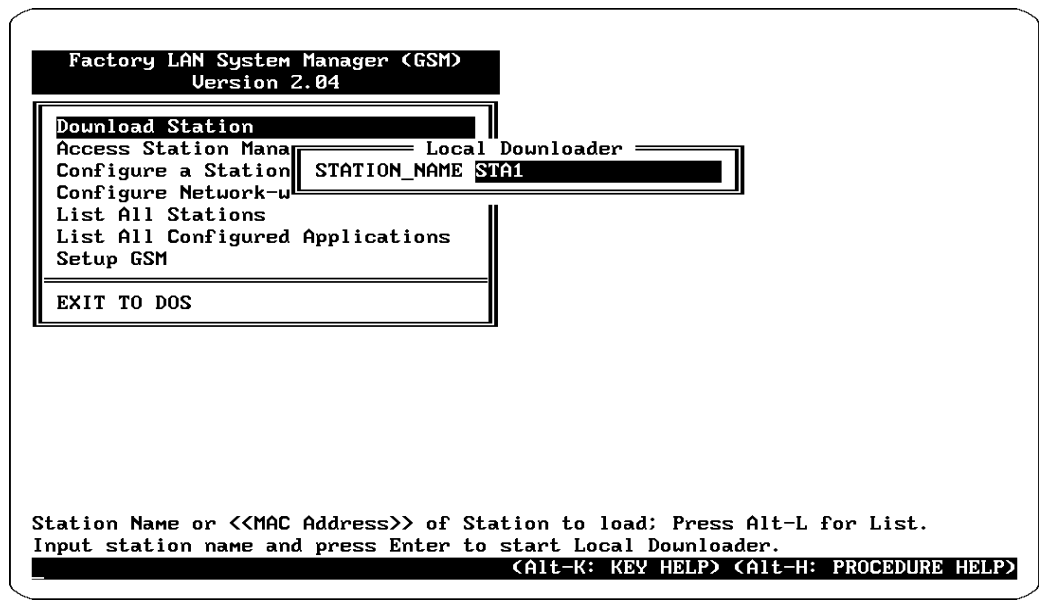

Figure 3-16. Download Station Screen

### Downloading Locally (Over the Serial Port)

If you have selected Local Download Mode in the GSM Setup menu, you will be prompted for the name of the station to be downloaded. This is the same 20 character name you used when you configured the station from the Configure a Station menu. Note that the station must be previously configured. As an alternate method of identifying the station to be downloaded, you may enter its MAC address, or you may select the station name from a list by entering Alt-L.

After you enter the STATION\_NAME, the GSM will download the communications software and configuration file over the serial link. It takes 5 minutes or more to serially

load a station, but it is necessary only to perform the procedure when you are performing a software or configuration upgrade to your LAN Interface.

There are 3 files that are downloaded to the LAN Interface. While the station is being downloaded, the name of the current file being loaded is displayed along with the file block count. The download may be aborted by pressing Alt-A key or Esc key. Once aborted, the download may not be resumed, but must be restarted from the beginning.

If an error occurs during the download process, an error message is displayed on the screen to indicate the nature of the error.

Once the download is complete, a message is displayed on the screen indicating that the download was successful. Control is then transferred automatically to the Local Station Manager Terminal screen so you may view the LAN Interface initialization messages.

## Downloading Over the Network

The Network Downloader uses a special download protocol to transfer information to the GENet LAN Interfaces on the network that require a download. The download protocol is described in this section.

1. The Network Downloader transmits a download multicast message once per second, when idle, to a specified multicast address.
2. The LAN Interface requiring a download receives the download multicast message and sends a "Request for Load" message to the Network Downloader. Download multicast addresses are defined in the GSM System Network Parameters menu. A Load Group number is assigned to each multicast address. Each LAN Interface must define a Load Group number so it obtains its download using the correct multicast address.

### Notes

The Network Downloader will support up to five different Load Groups each with a unique load multicast address and IEEE 802.4 slot time. This feature is not applicable to Ethernet (IEEE 802.3) networks and so the default Load Group 0 is sufficient.

3. When the Network Downloader receives a "Request for Load" message from a LAN Interface, it loads the necessary files into the LAN Interface across the LAN.

While the station is being downloaded, the name of the current file being loaded is displayed along with the file block count. If an error occurs during the download process, an error message is displayed on the screen to indicate the nature of the error.

If an error occurs in the Data Link software or hardware, an error code is displayed on the screen. Appendix J lists the error codes that can be displayed, along with their descriptions.

When the download is complete, a message is displayed on the screen indicating that the download was successful.

The Downloader transfers three files to the LAN Interface (in this order):

- \*.XFM - LAN Interface communications software.
- Cxxxxxx.xxx - LAN Interface configuration file.
- GO - Commands the LAN Interface to start execution of loaded software.

Before the LAN Interface is downloaded, the GSM Downloader will check the GSM System Files to see if the configuration file needs to be updated. The System Files consist of the System Slot Time and the Application DIBs. If any of these files have been updated more recently than the configuration file, the Downloader displays the following message.

```
System files integrated for Station: Station Name
```

### Note

The DOS time and date on the PC must be correct whenever the GSM is run, as the GSM uses the date and time associated with each file to determine if configuration files need to be updated.

The Network Downloader can also be entered directly from the DOS prompt by typing:

```
C:\GSM> gsm dnld
```

This can be used to invoke the Network Downloader from a batch file. This can be used to automatically run the Network Downloader after a power outage of the PC.

The Alt-F and Alt-P keys are used to enable and disable the logging of downloader activity to a user-specified file. The log file is automatically closed when returning to the GSM main menu.

The Esc key is used to exit the Network Downloader and to return to the GSM main menu.

### Notes

1. A LAN Interface **MUST** be configured on the GSM before it can be downloaded.
2. The LAN Interface Soft Switch, Network Load Address (LDMAC), must match one of the LOAD\_MULTICAST\_ADDR parameters on the GSM in order for a Network download to take place for the LAN Interface.
3. The MAC Address of the Station selected **MUST** match the LAN Interface MAC Address Soft Switch parameter (MAC) in order for the LAN Interface to be fully operational after loading.

## Section 4. Accessing the Station Manager

This section describes how to access the Station Manager software that resides on the Ethernet Interface.

### Access Station Manager Screen

The Access Station Manager Screen is used to access the Station Manager on the Ethernet Interface. This access will occur over either the serial port, or the network (depending on the selection in the System Network Parameters Menu). If you are using network access, you will be prompted for the name of the station you wish to access.

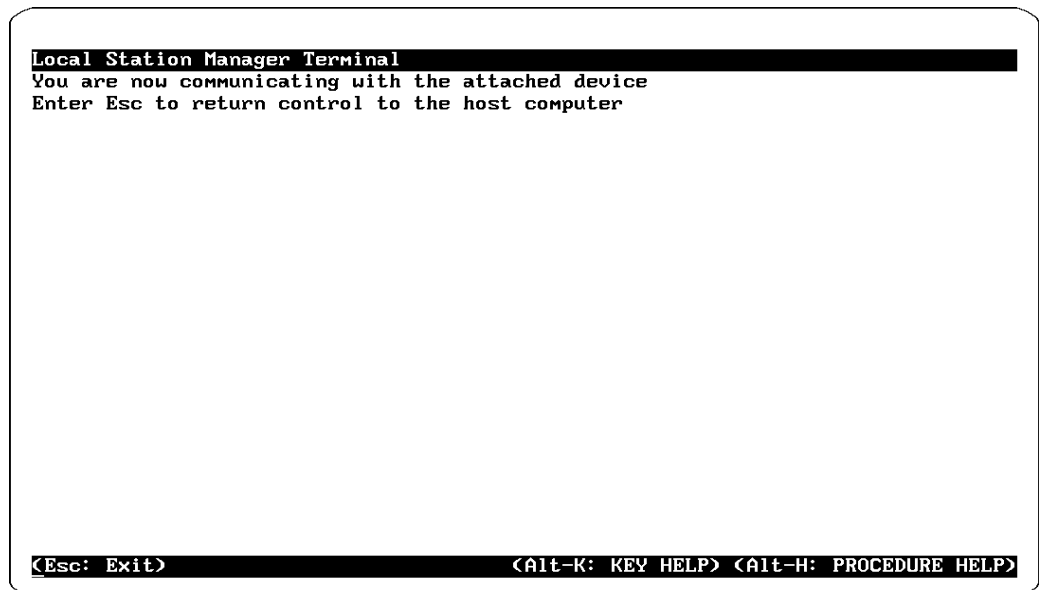

```
Local Station Manager Terminal
You are now communicating with the attached device
Enter Esc to return control to the host computer

<Esc> Exit                <Alt-K> KEY HELP <Alt-H> PROCEDURE HELP
```

Figure 3-17. Access Station Manager Screen

Once you are in the Access Station Manager screen, the PC acts like a dumb terminal connected to the Ethernet Interface. The GSM sets up the screen to display the interactions with the local Ethernet Interface Station Manager.

The logging of Station Management activity can be started or stopped from this menu. To request logging to start, press Alt-F. You will be prompted for the log file name. The log file is automatically closed when leaving this menu, or when you press Alt-P.



## Section 5. Using the GSM Support Functions

This section describes the GSM support functions. The GSM Menu topics discussed in this section are:

- List All Stations
- List all Configured Applications
- Setup GSM
- Exit to DOS

### List All Stations Screen

The List All Stations screen displays a list of all of stations that are configured in the GSM directory on the hard disk. A typical List All Stations screen is shown below.

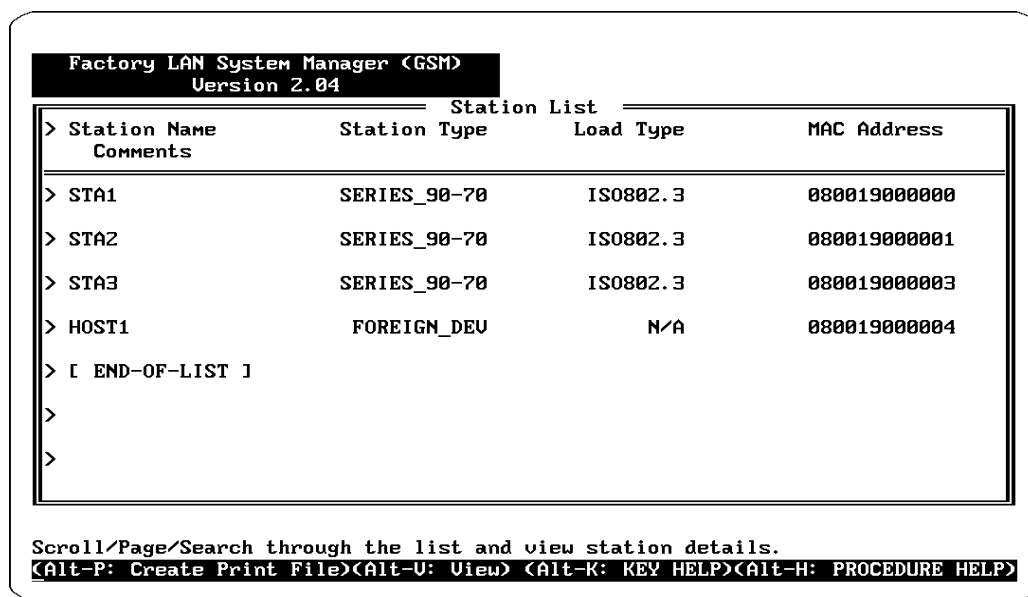

Figure 3-18. List All Stations Screen

This screen displays the following information about each station:

- Station Name
- Station Type
- Load Type
- Station MAC Address
- Comments

Use the Up Arrow, Down Arrow, PgUp, PgDn, Home, and End keys to examine the list of configured stations. The details about a specific station can be examined by pressing

the Alt-V key. When you press the Alt-V key, you are prompted for the name of the station to examine. If you enter a blank field, the top item in the menu is examined.

The detailed information about a specific station additionally includes:

- Configuration File Name
- Date and time Last configured
- Date and time Last Downloaded
- Station's Load Group (with values selected by the Load Group)

The Alt-S key is used to search the list of stations for a specified entry. When you press the Alt-S key, you select the data field and value to seek and select the search direction. Press the Alt-S key again to initiate the search, or the Esc key to abort the search.

Press the Alt-P key to create a list file, "STANAMES.LIS", of the configured stations. Press the Esc key to exit the Show Stations screen and to return to the GSM Main menu.

## List All Configured Application DIBs Menu

The List All Configured Applications DIBs Menu allows access to the 7-Layer and 3-Layer miniMAP Application DIB screens. The DIB screens display the contents of the network-wide Application DIBs (Directory Information Bases).

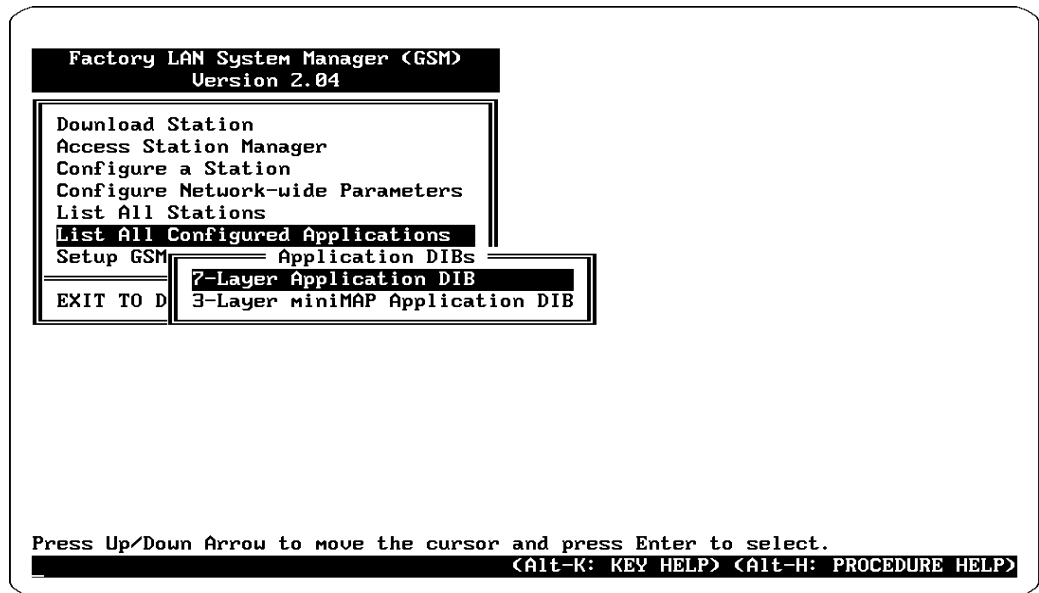

Figure 3-19. List All Configured Applications Menu

## 7-Layer Application DIB Screen

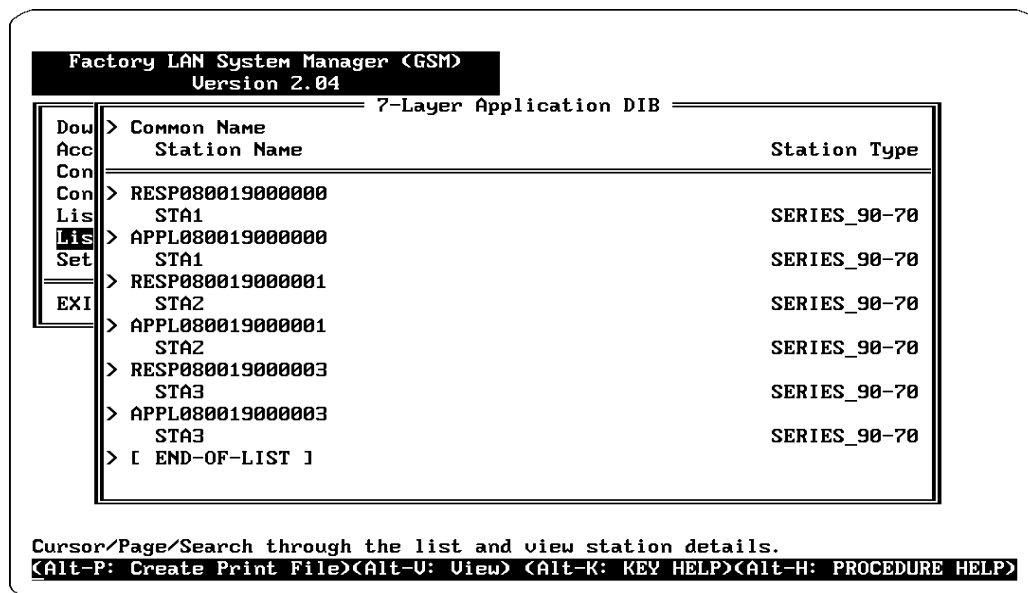

Figure 3-20. 7-Layer Application DIB Screen

The 7-Layer Application DIB (Directory Information Base) menu displays the network wide Directory Information Base for full 7-Layer communications. This DIB is a table which contains directory information about every Application Process (identified by Common Name) that may be accessed by a GENet Application Process. Information is automatically placed into the 7-Layer Application DIB whenever an Application Process (identified by Common Name) is defined through the configuration of a station.

For each listed application, the display shows the Common Name, Station Name, and Station Type. In addition, you may request more detail for any listed application by pressing the Alt-V key.

The DIB may be examined using the Up Arrow, Down Arrow, PgUp, PgDn, Home, and End keys. The details about a specific DIB entry can be examined by pressing the Alt-V key. When the Alt-V key is pressed, you are prompted for which DIB entry to examine. If a blank field is entered, the top item in the menu is examined.

The Alt-S key is used to search the DIB for a specified entry. When the Alt-S key is pressed, you select the data field and value to seek and select the search direction. The Alt-S key is pressed again to initiate the search, or the Esc key is pressed to abort the search.

The Alt-P key is used to produce a file, MAPDIB.LIS, containing a printable form of the information in the DIB. This file can then be typed or printed.

The Esc key is used to exit the 7-Layer Application DIB menu and to return to the Application DIBs menu.

## Setup GSM Menu

The Setup GSM screen (shown below) includes the following functions.

- Change the password that must be entered to access the GSM main menu
- Set Download Mode (Local or Network)
- Set Station Manager Mode (Local or Network)

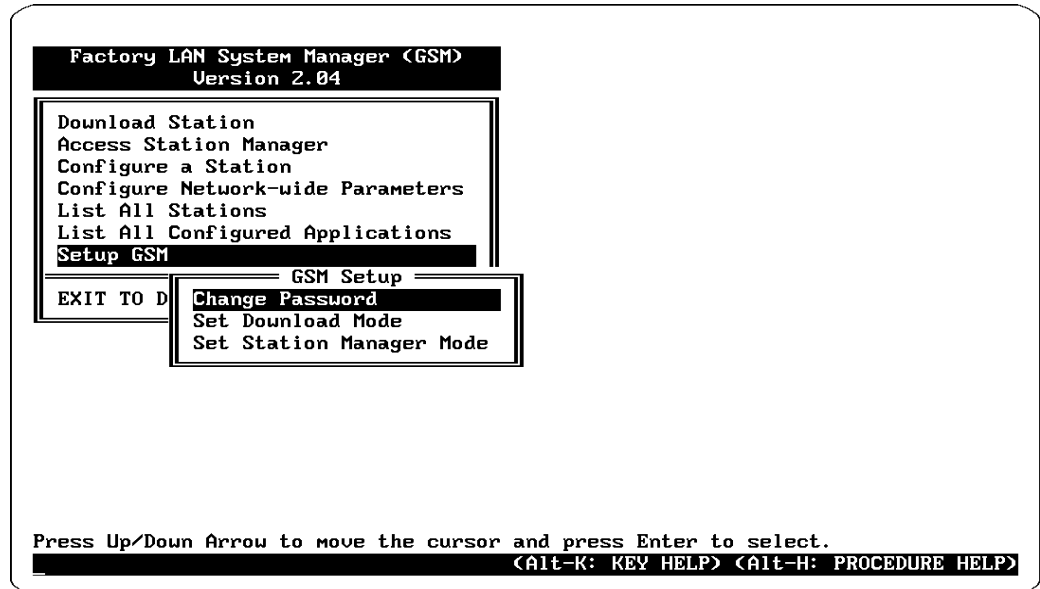

Figure 3-21. Setup GSM Menu

## Changing the GSM Password Screen

When you select this function, the GSM clears the screen, and prompts for the following information:

```

Enter old password:
Enter new password:
Verify new password:

```

You are given three chances to enter the above information properly. Please note that all characters which are typed after the password prompt except for the Return key are assumed to be part of the password. Specifically, the delete and backspace characters do not have their usual meaning and are interpreted simply as password characters. When this process is completed (successfully or unsuccessfully), control is returned to the GSM main menu.

### Note

The password is case sensitive.

---

## Set Download Mode Screen

This screen permits you to toggle the download mode between Local and Remote.

### To Set the Download Mode:

1. Enter the Set Download Mode Screen.
2. Press Tab to toggle the Mode.
3. Press Alt-U to update.
4. Press Esc to return to the GSM Main Menu.

## Set Station Manager Mode Screen

This screen permits you to toggle the Station Manager mode between Local and Remote.

### To Set the Station Manager Mode:

1. Enter the Set Station Manager Mode Screen.
2. Press Tab to toggle the Mode.
3. Press Alt-U to update.
4. Press Esc to return to the GSM Main Menu.

### Note

You can also toggle the Station Manager Mode by pressing Alt-M from the GSM Main Menu.

## Exit to DOS

When the EXIT TO DOS menu item is selected, the GSM clears the screen, and returns control to the PC operating system.

# Chapter 4

## *The Station Manager*

---

---

This chapter describes how to access and use the Station Manager software which resides on the Ethernet Interface. Each command is also defined here. The chapter is divided into three sections.

- Section 1. Accessing the Station Manager
- Section 2. Using the Station Manager
- Section 3. Command Descriptions

The Station Manager is a part of the communications software in the Ethernet Interface. The Station Manager executes as a background function on the Ethernet module to provide interactive supervisory access to the interface.

The Station Manager is available when the Ethernet Interface is fully operational or when it is running either the Soft Switch Entry or Field Network Test utilities. The Station Manager is not available when running Power-Up Diagnostics or the Loader Utility.

### **Station Manager Services**

The Station Manager provides the following services:

- An interactive set of commands to interrogate and control the Ethernet Interface.
- Access to observe internal statistics, an exception log, and configuration parameters.
- Password security for commands that change the Interface parameters or states.

The Station Manager allows you to monitor the operation of the local station and the network. If a problem occurs at the local station or on the network, the Station Manager may be used to pinpoint the source of the problem through the various Monitor commands.

## Section 1: Accessing the Station Manager

The Station Manager on the Ethernet Interface can be accessed in three primary ways:

1. **Through the 9-pin serial port on the Ethernet Interface** by a GEnet System Manager (GSM) in Local Station Manager Mode or by an ASCII terminal. See Figure 4-1.
2. **Directly over the Ethernet network** by a GSM in Network Station Manager Mode. See Figure 4-2.
3. **Remotely over the Ethernet network via another Ethernet Interface** with an attached GSM in Local Station Manager Mode or by an ASCII terminal. This method requires the use of the REM (Remote) command to access the remote station. See Figure 4-3.

A limited access to the Station Manager is also provided to the local PLC ladder program.

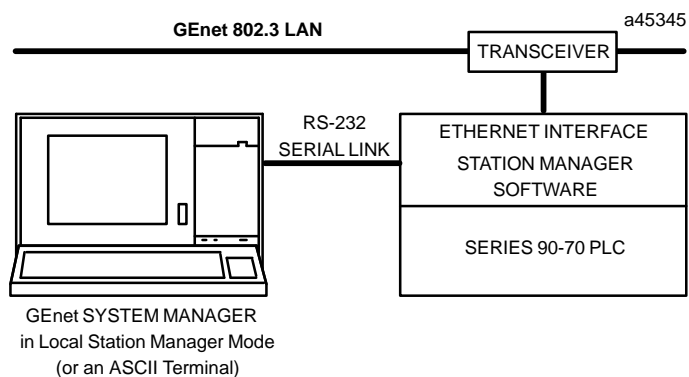

Figure 4-1. Station Manager Accessed Locally through the 9-pin Serial Port by a GSM in Local Station Manager Mode (or an ASCII Terminal)

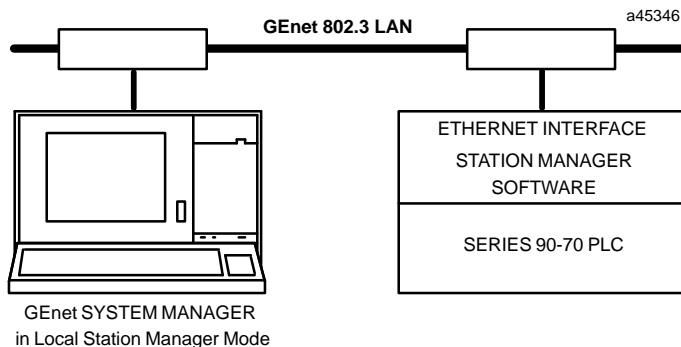

Figure 4-2. Station Manager Accessed Directly over the Network by a GSM in Network Station Manager Mode

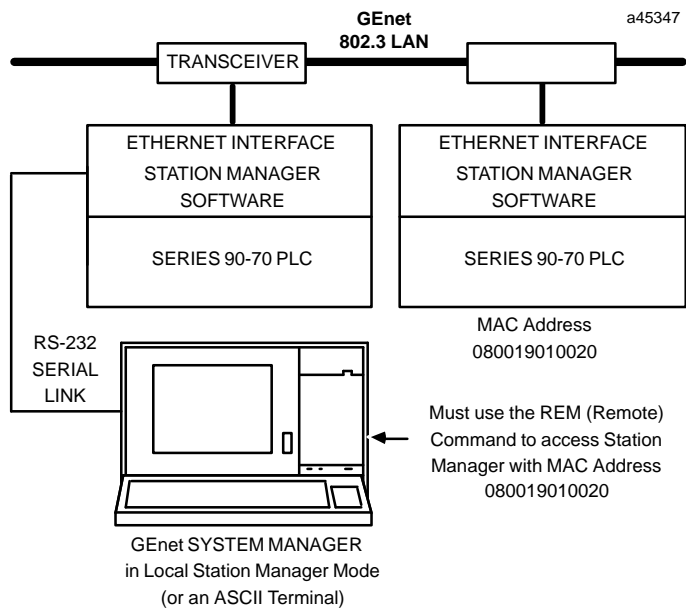

Figure 4-3. Station Manager Accessed Remotely over the Network by a GSM in Local Station Manager Mode using the REM (Remote) Command

## Accessing the Station Manager Using the GSM

The Station Manager may be accessed by connecting the Ethernet Interface to a Workmaster or IBM PC Compatible computer running the GSM software in Local or Network Station Manager mode.

1. Do either A or B below as desired.
  - D. **Local Connection.** Connect the COM1 RS-232 serial port on the device running the GSM to the 9-pin connector on the Ethernet Interface. Refer to Appendix D, for instructions on how to make the RS-232 cable.
  - E. **Network Connection.** Connect the Ethernet Interface on the device running the GSM to the Ethernet Network.
2. Power-up the computer running the GSM into DOS. (See Chapter 3. The GEnet System Manager for installation of the GSM).
3. Set the PC default directory to the GSM directory, by typing:
 

```
C:\> cd gsm
```
4. Start-up the GSM by typing:
 

```
C:\GSM> gsm
```
5. Once the GSM Main Menu appears, go into the Setup GSM functions to set the Station Manager Mode to Network or Local.



6. From the GSM Main Menu, cursor to the Access Station Manager function and press Enter.
  - A. **Local Mode.** If you are in Local Mode you will automatically go into the Station Manager of the locally connected Ethernet Interface.

### Note

When you enter the Local Station Manager or the Local Downloader, the GSM automatically configures COM1 of the PC as follows:

```
9600 bits per second
8 data bits
No parity
1 stop bit
```

COM1 will retain this configuration even after exiting the Local Station Manager or Local Downloader.

- B. **Network Mode.** If you are in Network Mode, you will be prompted to enter the Station Name or MAC address of the station you want to access.

## Accessing the Station Manager Using an ASCII Terminal

1. Connect a serial cable from the ASCII terminal to the 9-pin connector of the Ethernet Interface. Refer to Appendix D, for instructions on making the cable.
2. Set up the communication parameters of the terminal as follows:

```
9600 bits per second
8 data bits
No parity
1 stop bit
```

3. Press the Enter key to see the Station Manager prompt character.

## Remote Operation of the Station Manager

The Station Manager commands can be invoked over the network from other GENet devices (other Series 90-70 PLC Ethernet Interfaces, GE Fanuc CNC OSI-Ethernet Interfaces, Series Six PLC LAN Interfaces, or remote GENet System Managers) by using the *REM* command. When invoked remotely, the Station Manager software processes the command as if it had been entered from a device attached to the serial port but automatically directs output from the command over the LAN to the station which issued the request. There is no indication on the local station serial device when a remote command is being processed. Refer to Figure 4-2 for LAN configurations that use remote Station Manager operations.

### Note

Both the local console and any remote access share the same security level. See the "LOGIN" and "LOGOUT" commands descriptions.

---

## Accessing the Station Manager from the Local PLC

The Station Manager Ladder COMMunication REQuests allow the ladder program within the local PLC to retrieve some of the same management information that is available through the Station Manager. There are four Station Manager ladder requests.

- Retrieve Extended Status Buffer Request
- Retrieve Tallies Request
- Retrieve Log Events Request
- Restart Ethernet Interface

Refer to Chapter 7 for a complete description of the COMM\_REQs for these requests.

---

## Section 2: Using the Station Manager

The Station Manager commands are divided into two groups:

- Monitor commands
- Modify commands

The *Monitor* commands provide information about the station and the network. Executing these commands will not affect the operation of the station or the network, and they are available to anyone using the Station Manager. See Table 4-1 for a list of Monitor commands.

The *Modify* commands perform functions that may change the operation of the station and the network. These commands are secure and may only be executed when the secure level of operation has been selected by “logging in” with the current password. These commands will be printed in italics. See Table 4-2 for a list of Modify commands.

The complete sets of Monitor commands and Modify commands are available when the Ethernet Interface is in the fully operational state. Subsets of these commands are available when in the Soft Switch Entry and Field Network Test Utilities.

The Station Manager is a “background” task. It only executes when communication processing is not occurring. Because of this, the command response time is sensitive to the communication load of the station—the greater the load, the longer it takes for the commands to execute.

## Using the Monitor Commands

All of the Monitor commands can be executed from either the Monitor “>” prompt or the Modify “=” prompt. To display a list of the Monitor commands on the screen, type:

```
HELP <RET>      or
? <RET>
```

The following table provides a brief description of the Monitor commands.

**Table 4-1. Monitor Commands**

Command	Description
?	Displaylist of commands
acb	Display list of active Association Control Blocks
bps	Display serial port data rate
cap	DisplayCapabilities
date	Displaycurrent date
exs	Display Extended Status buffer
help	Display list of commands
log	DisplayError log
login	Login for Modify mode
ltime	Display login timeout
mdib	Display 7-Layer Application DIB
node	Displaysign-on message
pi	Display Program Invocation
rib	Display Routing Information Base
show	Display a configuration parameter 's value, or list the configuration parameters for a task(s)
sosw	Display current Soft Switch data
stat	Display task(s) status
tally	Display task(s) tallies
time	Display current time
var	Display VMD specific variable names
vmd	Display VMD state

For most commands, simply enter the command and press Enter. Some commands require additional information to be entered along with the command. Those arguments should be separated from the command and from each other by one or more spaces. The Command Descriptions section in this chapter provides a complete description of each command.

The LOGIN command is required to access the Modify commands. To execute the LOGIN command you must know the current password.

## Using the Monitor Commands to Troubleshoot the Network

There are three Monitor commands that are especially useful to troubleshoot the network:

- The EXS command
- The LOG command
- The TALLY command

**EXS Command:** The EXS command displays the Extended Status Buffer. This buffer maintains information about COMM\_REQs issued to this Ethernet Interface from the PLC ladder program of the local station.

**LOG Command:** The LOG command displays a log of exception conditions occurring at the local station. The events are counted, time stamped, and differentiated by an error code.

**TALLY Command:** The TALLY command displays counts of transactions of the specific tasks.

## Using the Modify Commands

To use any of the Modify commands you must obtain the modify “=” prompt using the LOGIN command. To do this you must know the current password. The factory default password is “system” (lower case characters).

To log in, type from the “>” prompt:

```
LOGIN <RET>
```

The password prompt will then be displayed.

```
Password:
```

Type in the current password and press Enter. If the entered password matches the current password for the station, the modify “=” prompt is displayed. The password is case sensitive.

One may execute all Monitor and Modify commands from the Modify “=” prompt. If no commands are executed within 10 minutes, the Modify login will time-out and you will have to login again. This 10 minute timeout between commands can be changed if desired by using the *CHLTIME* command.

### Note

The security feature is intended to prevent inadvertent misuse of the Modify commands. It is not a foolproof mechanism to prevent unauthorized changes. For the greatest protection, restrict the number of people who know the password, restrict access to the Station Manager terminal, and always log off when you leave the Station Manager.

To list the Monitor commands and Modify commands on the screen, type:

```
HELP <RET> or
```

```
? <RET>
```

The following table provides a brief description of the Modify commands.

**Table 4-2. Modify Commands**

<b>Command</b>	<b>Description</b>
<i>chbps</i>	Change serial port data rate
<i>chdate</i>	Change date
<i>chltime</i>	Change login timeout
<i>chsosw</i>	Change Soft Switch data
<i>chtime</i>	Change time
<i>clear</i>	Clear Extended Status buffer, Error Log, Tallies, or Heap
<i>clsosw</i>	Clear Soft Switch values on Ethernet Interface
<i>load</i>	Force Ethernet Interface to be loaded
<i>logout</i>	Exit modify mode
<i>net</i>	Disable/Enable node from network
<i>ok</i>	Turns on STATUS OK LED
<i>rem</i>	Send command to remote station
<i>report</i>	Report test results
<i>restart</i>	Restart the Ethernet Interface
<i>stopt</i>	Stop test command
<i>test</i>	Send test commands to station(s)
<i>trace</i>	Turn on specific task trace flags

## Date and Time

The Station Manager provides commands to examine the date and time. Any time the Ethernet Interface is restarted or power to it is cycled, it will attempt to read the date and time from the PLC. If this fails, the time reverts to midnight and the date to January 1, 1989. If accurate time stamp information is to be generated in the Exception Log, the system date and time must be set using the Station Manager.

# Station Manager Command Syntax

The Command Descriptions section which follows provides an alphabetical listing of the commands. Each entry describes the input and output for each command.

All commands have the format of a command followed by a variable number of arguments separated by spaces. Details about the arguments are discussed with each command. All arguments to the commands, will be automatically converted to all lower case characters unless they are enclosed in double quotation marks (e.g., "A").

## Task Identification

Several commands refer to "tasks" or subsystems of the operating software. Each task has a unique identifying letter which is used to select the desired task or tasks. The following table shows the task identifiers and their associated tasks.

**Table 4-3. Task Identifiers**

<b>Identifier</b>	<b>Task</b>	<b>Identifier</b>	<b>Task</b>
a	ApplicationLayer	b	SystemMemory
c	PLCDriver	d	DistributedDirectory Protocol (DDP)
e	ACSE	l	Data Link Layer
m	MMS Provider	n	NetworkLayer
p	PresentationLayer	s	SessionLayer
t	TransportLayer	v	SRTP ServiceAgent
y	SystemData Manager		

## Display Data Representation

The data that is displayed by the Station Manager is formatted in one of several ways depending on the type of data being input or output.

### Numeric Values

Numeric values are displayed as decimal values with the hexadecimal equivalent printed in parenthesis beside it. An exception is baud rate which are printed only in decimal. Hexadecimal values are represented with a "H" as their last character.

An example of numeric output is shown below.

```
stime = 2500 (09c4H)
```

When numeric values are entered, they may be entered as either a decimal value or as a hexadecimal value. Hexadecimal values must be entered using the trailing "H" (either upper or lower case) as their last character.

### Character Strings Values

Character strings are delimited by double quote characters. An example of character string output is shown below.

```
arespcnam = "Station 24 Responder"
```

### Octet String Values

Octet strings represent each successive octet as a pair of hexadecimal digits enclosed in double angle brackets (<<...>>). Examples of octet string output are shown below.

```
stsap = <<0001>>  
MAC address = <<080019010842>>
```

### Object Identifier Values

Object identifiers are displayed as a sequence of decimal values separated by spaces and delimited by brackets ({...}). An example of object identifier output is shown below.

```
mmsacnobj = {1 0 9506 2 1}
```

### Note

The Ethernet Interface has a limited output buffer for storing Station Manager command results. If a command's output exceeds this size, part of the command output will be lost, and will not be displayed.



## Station Manager in Utility Programs

The Ethernet Interface has two utility functions provided as a part of the PROM-based software. These utilities allow selected station management functions to be performed, even when no operating software is loaded. This allows the Ethernet Interface hardware and the network to be verified without requiring that any software be loaded into the Ethernet Interface.

### Soft Switch Entry Utility

The Ethernet Interface stores its Soft Switch data in an EEPROM. If Soft Switches have not been configured through LogiMaster 90-70 and the values in the EEPROM are invalid, the Soft Switch Entry Utility is entered. Also, when certain other faults are detected, control will revert to the Soft Switch Entry Utility.

#### Caution

**The Soft Switch parameters are critical to proper startup of the Ethernet Interface. Improper settings of Soft Switch values can prevent the station from functioning with the PLC, from being loaded, or from being accessible to other stations on the network.**

**The Soft Switch Entry Utility is entered if the data in the Soft Switches are determined to be invalid on power-up or restart of the Ethernet Interface, or if certain other faults occur.**

The Soft Switch Entry Utility runs a subset of the Station Manager commands. It provides a unique prompt, an asterisk (“\*”). The Station Manager commands shown in the following table can be used while in the Soft Switch Entry utility. Some of the commands have restrictions due to the limited services available in this utility.

All commands in the Soft Switch Entry Utility are accessible at the initial security level. It is not necessary to login to use the Modify commands while in the Soft Switch Entry utility.

A typical initialization message from the Soft Switch Entry utility is shown below:

```
IC697 PLC Factory LAN Interface
Copyright (c) 1990-1994. All rights reserved.
PROM Version 1.14 Ethernet
MAC address = <<08001901001f>>
Serial no. 01393790, MAC default = <<08001901001f>>

<<< Soft Switch Entry Utility >>>

Soft Switch Values Not Defined
*
```

Just before the “\*” prompt is printed, the reason for entry into the Soft Switch Entry Utility is printed. Some examples of entry reasons are: soft switch values not defined,

PROM/software versions are incompatible, or station MAC address in soft switches does not match downloaded configuration.

**Table 4-4. Soft Switch Entry Utility Commands**

Command	Restrictions
bps	Limited to clear tally, clear log, and clear heap
<i>chbps</i>	
<i>chdate</i>	
<i>chsosw</i>	
<i>chtime</i>	
<i>clear</i>	
<i>clsosw</i>	
date	
help or ?	
<i>load</i>	
log	
login	
node	
<i>ok</i>	
<i>restart</i>	
show	Only task identifiers "b" and "c" are supported
sosw	Only task identifiers "b" and "c" are supported
stat	
tally	
time	Only task identifiers "b" and "c" are supported

Monitor Commands are not in italics. Modify commands shown in *italics*

If the Soft Switch values are not defined or disagree with other evidence, the problem must be satisfactorily resolved by one or more of the following actions:

1. Set the MAC address to the correct value via Logicmaster 90 Configurator.
2. If not configured via Logicmaster 90, use the *CHSOSW* Station Manager command described in this chapter.
3. Adjust the GSM configuration for the GENet Ethernet Interface.
4. Download the Ethernet Interface from the GSM.

Otherwise, you will be continually placed back into this utility after each restart. For proper usage of the *CHSOSW* command, see the *CHSOSW* command description in this chapter.

The Soft Switch Entry utility is exited by restarting the Ethernet Interface. This can be accomplished by entering the *RESTART* or *LOAD* commands, pressing the Ethernet Interface Restart pushbutton, or by cycling power on the Series 90-70 PLC.

## Field Network Test Utility

It is often useful to check the proper operation of the network before all of the station configuration parameters are finalized. The Field Network Test utility provides access to a subset of the Station Manager commands that allow the station to operate as a member of the network without requiring any software or configuration data to be loaded. Installation Procedure 5 (in Chapter 2) provides detailed instructions for checking the operation of a node across the physical network to all other nodes.

The Field Network Test utility can be entered only during a brief interval at the end of power-up diagnostics. When power-up diagnostics are completed, the character "@" is displayed on the Station Manager terminal and a three-second opportunity to enter the Field Network Test Utility begins. If the character "F" or "f" is entered at the local Station Manager terminal during this three-second window, the Field Network Test utility will be entered. Any character except "F" or "f" is ignored. After three seconds, the window for entering the Field Network Test utility closes and system initialization proceeds. Note that these characters are not echoed back.

A typical invocation of the Field Network Test utility is shown below:

```
@          ("F" or "f" character is entered within 3 seconds)
IC697 PLC Factory LAN Interface
Copyright (c) 1990-1994. All rights reserved.
PROM Version 1.14 Ethernet
MAC address = <<08001901001f>>
Serial no. 01393790, MAC default = <<08001901001f>>

<<< Field Network Test Utility >>>
$
```

After the station enters the network, the Station Manager commands shown in the following table can be used to test the network. Some of the commands have restrictions due to the limited resources available in this utility.

**Table 4-5. Field Network Test Utility Commands**

Command	Restrictions
<i>bps</i>	
<i>chbps</i>	
<i>chdate</i>	
<i>chsosw</i>	
<i>chtime</i>	
<i>clear</i>	Limited to clear tally, clear log, clear heap, and clear exs.
<i>clsosw</i>	
<i>date</i>	
<i>help</i> or ?	
<i>load</i>	
<i>log</i>	
<i>login</i>	
<i>net</i>	
<i>node</i>	
<i>ok</i>	
<i>rem</i>	
<i>report</i>	
<i>restart</i>	
<i>show</i>	Only task identifiers "b", "c", and "l" are supported.
<i>sosw</i>	
<i>stopt</i>	
<i>stat</i>	Only task identifiers "b", "c", and "l" are supported
<i>tally</i>	Only task identifiers "b", "c", and "l" are supported
<i>test</i>	
<i>time</i>	

Monitor Commands are not in italics.

Modify Commands are shown in *italics*

The Field Network Test utility is exited by restarting the Ethernet Interface. This can be accomplished by entering the RESTART or LOAD commands, pressing the Ethernet Interface Restart button, or by cycling power on the Series 90-70 PLC.

## Section 3: Station Manager Command Descriptions

Symbols are used to denote options or alternatives in the command parameters. These symbols are used to help give a clear and complete description of the command and are not part of the command. The use of these symbols is briefly described below:

*Arguments* to commands are often given symbolic names which are enclosed in angle brackets (< >). For example; "<PAGE>" is an argument to many commands. The command specification for "<PAGE>" is described as a number which specifies the page number of the display. It is important to remember to enter the argument and not its symbolic name. For example, to see the second page of the 7-Layer Application DIB, one should enter:

```
MDIB 2 - not - MDIB <PAGE>
```

*Optional arguments* are surrounded by square brackets, for example *REPORT* <PAGE>]. Again, the brackets should not be entered as part of the command.

Sometimes there are several *alternatives* for an argument. The alternatives are listed in the command description separated by a vertical bar (|) and enclosed in braces ({|}). For example, when using the *CLEAR* command, only one of the alternatives should be selected:

```
CLEAR { EXS | LOG | TALLY | HEAP }
```

### Command Input Processing

Anything in a command description that is not one of the constructs discussed above should be entered exactly as it is shown. All data entered for the command is converted to lower case unless it is enclosed in double quotes (""). To use a double quote character within an argument string, the double quote should be entered twice, for example: "This string would contain one "" character."

The Station Manager accepts several ASCII control characters for various functions. The control characters accepted by the Station Manager are listed in the following table. All other control characters are ignored on normal command inputs. Illegal control characters sent to the Station Manager result in a BEL character being sent to the terminal.

Table 4-6. Control Characters

Control Character	Usual Keyboard Function	Function
BS	Ctrl-H (Backspace)	Delete previous character
DEL	Delete	Delete previous character
DC1	Ctrl-Q	Resume output to the display
DC2	Ctrl-R	Recall previous command line
DC3	Ctrl-S	Stop output to the display
CAN	Ctrl-X	Cancel the current input line
CR	Return (Enter)	Terminate line and execute command

If a command line becomes too long to easily type on a single display line, the character pair "\<RET>" can be used to continue the command on the next line on the display. The "\" (backslash) character will not be used as a part of any argument.

## ACB Command

The ACB command has the form:

```
> acb [<ACBaddr>[, <ACBaddr>[, ...]]] | All
```

where <ACBaddr> is of the form [%] <MMS Symbolic Address>. The possible SymbolicAddresses for Series 90-70 Ethernet Interfaces are described in Chapter 6.

This command displays the contents of a specific ACB (Association Control Block) as understood by the Ethernet Interface at the time the command is issued. The command does *not* read the ACB from the PLC across the back plane.

If the command ACB ALL is issued, the ACB content of all active associations are displayed.

This means that the Logicmaster display of the ACB location could differ from the Station Manager display for two reasons:

1. The Ethernet Interface is in the process of updating the PLC memory, or
2. The Ethernet Interface is unable to update the PLC memory.

A typical ACB command is shown below:

```
> acb r16,%i35,xyz,R999999,r015  
  
R0016: ASW: 0001H ASWE: 4000H Invoke ID: 00000000H Prob code:  
0000H  
I0035: ASW: 0421H ASWE: 0000H Invoke ID: 00000073H Prob code:  
0007H  
XYZ: Invalid ACB location specified  
R999999: ACB address is out of range  
R0015: No ACB exists at the specified memory location
```

There is one line of output per ACB. Each line is preceded by the ACB location entered by the user. The ACB locations are displayed in the order in which they were entered. Error checking is done on the address entered to make sure that:

1. The address format is valid,
2. The memory location is within the configured range for that memory type, and
3. An actual ACB exists at that memory location.

## BPS Command

The BPS command has the form:

```
BPS
```

This command causes the current serial port data rate to be displayed. A typical BPS command is shown below:

```
> bps  
bps = 9600
```

## CAP Command

The CAP command has the form:

```
CAP
```

This command displays the MMS capabilities currently configured for the station. A typical CAP command is shown below:

```
> cap
<<< Capabilities >>>
"BASEADDR"
"Conveyor Belt"
"HIGHADDR = %I1024 %Q1024 %R16384"
```

## CHBPS Command

The CHBPS command has the form:

```
CHBPS { 9600 | 2400 | 1200 | 300 }
```

where one of the data rate selection values is entered

This command is used to change the data rate on the serial port of the Ethernet Interface. Any input or output from the serial port after the command has been successfully entered will use the modified data rate. The data rate remains in effect until it is again explicitly changed or until the Ethernet Interface is restarted. The default data rate is 9600 bps.

A typical CHBPS command is shown below:

```
= chbps 1200
bps = 1200
```

If the output device attached to the serial port is not set to the new data rate, the BPS command message will be lost or garbled.

## CHDATE Command

The CHDATE command has the form:

```
CHDATE <DD-MMM-YYYY>
(an example date is: 01-JAN-1989)
```

This command is used to change the system date to the date specified in the command. No date earlier than Jan 1, 1989 may be entered. If an invalid date is entered, the current date is not changed. Date changes remain in effect until the Ethernet Interface is powered-up or restarted.

A typical CHDATE command is shown below:

```
= chdate 24-MAY-1990
Date = 24-MAY-1990
```

### CHLTIME Command

The *CHLTIME* command has the form:

```
CHLTIME <minutes>
```

where <minutes> is a login timeout value expressed in minutes which has a range of 0 to 32767

The *CHLTIME* command is used to change the login timeout value. This change remains in effect until it is explicitly changed or until the next *LOGOUT* command is entered. If the number of minutes specified is zero, no timeout is enforced.

A typical *CHLTIME* command is shown below:

```
= chltime 5  
Login timeout = 5 min
```

### CHSOSW Command

The *CHSOSW* command has the form:

```
CHSOSW {<soft switch data>|def}
```

where <soft switch data> is the parameter string

```
[mac <MAC_address>]  
[ldsrc <load_source>] [lanonline <yes_no>]  
[bponline <yes_no>] [ldmac <load_addr>]  
[mms <enable>] [pgmr <enable>]  
[enable = {dc | req | prhb}]
```

and where

```
<yes_no> = {yes | no}  
<load_source> = {alt | net | loc}  
<enable> = {dc | req | prhd}
```

and “CHSOSW def ” causes default values to be set

The *CHSOSW* command causes new data to be placed into the Soft Switches (EEPROM) of the Ethernet Interface.

### Notes

1. The changes made with either the Logicmaster 90 Configurator or the *CHSOSW* command will not take effect until the next Ethernet Interface restart.
2. If the PLC CPU has been properly configured through the Logicmaster 90 Configurator (the normal case), the *CHSOSW* Command will not be honored.

The Soft Switch data parameters must be entered as specified above. The parameter label (mac, ldsrc, lanonline, bponline, ldmac, mms, or pgmr) must precede the new parameter value.



The <MAC\_address> parameter is the station's working MAC address. This parameter is entered as an octet string. A value of all 0's for this parameter means that the permanent globally administered station address (Default Station Address) is used. This parameter may not be a multicast or a broadcast address. See the sub-section titled "Structure of the MAC Address" in Chapter 3, Section 2.

The <load\_source> parameter indicates the source of the communications software download. This parameter should be one of the ASCII string values shown in the table below.

**Table 4-7. Load Source Parameters**

Parameter Value	Description
ALT *	Alternate between all possible load sources
LOC	Load from local serial port
NET	Load from network

\* Default Value

The <yes\_no> parameter indicates whether the Ethernet Interface will initialize and enter the network or initialize the Backplane Communications with the CPU. This parameter has a value of YES or NO.

The <load\_addr> parameter is the multicast address used by the Ethernet Interface for network loads. This parameter is entered as an octet string. A value of all 0's for this parameter means the default multicast load address <<090060000000>> is used. This parameter may not be the broadcast address, but must be a multicast address.

The mms and pgmr <enable> parameters define the type of communications software which can download the Ethernet Interface. mms refers to full MMS communications software; pgmr refers to the communications software downloaded by Logicmaster 90 software. <enable> = {dc | req | prhb} defines further conditions of the download (where dc = Don't Care, req = Required, prhb = Prohibited. The default is Don't Care).

For example, the command "*CHSOSWPGMR PRHB*" prohibits the Logicmaster 90 Network Utilities from downloading this Ethernet Interface. Only the GSM can download this interface. In addition, once the interface is downloaded, Logicmaster 90-Ethernet Utilities will be prevented from connecting to this PLC system. Refer also to the *Logicmaster 90-Ethernet Communications User's Manual*, GFK-0780.

The *CHSOSW* command does not require that every parameter be entered. If a Soft Switch label/value pair is omitted, one of two results occur depending on the current Soft Switch data. If the current data is determined to be valid, any parameters that are not entered are left unchanged. However, if the Soft Switch data is determined to be invalid, all parameters omitted are set to their respective default values. Default values are shown in the table below. At least one parameter label/value pair must be entered.

Using the *CHSOSW* command with the single parameter "def" causes all Soft Switch values to be set to their defaults.

If the Soft Switches have been determined to be invalid, the Soft Switch Entry Utility is entered upon power-up or restart. Once in this utility, you **MUST** correct the problem either with the Logicmaster 90 Configurator or with a *CHSOSW* command before exiting. Otherwise, the Soft Switch Utility will automatically be re-entered after a power-up or restart.

**Table 4-8. Soft Switch Default Values for the Ethernet Interface**

Soft Switch	Default Value
MACaddress	<<000000000000>>
Loadsource	ALT
LANonline	YES
BP online	YES
Networkloadaddress	<<090060000000>>
MMS enable	Don't Care
PGMREnable	Don't Care

A typical output from the *CHSOSW* command is shown below.

```
= chsosw ldsrsrc loc
<<< Soft Switch Data >>>
MAC address = <<080019011234>> (default used)
Load source = Serial
Network Online = Online after powerup
Backplane Online = Online after powerup
Network load addr = <<090060000000>> (default used)
MMS Enable = Don't Care
Pgm Enable = Don't Care
Updating, please wait ...
```

## ***CHTIME* Command**

The *CHTIME* command has the form:

```
CHTIME <HH[:MM]>
```

where <HH> is an hour in the range 0-23  
 <MM> is an optional minute in the range 0-59 which defaults to 0  
 <SS> is an optional second in the range 0-59  
 which defaults to 0

This command sets the current system time to the value specified. If an invalid time is entered, the current time is not changed. Leading zeros do not need to be entered when entering the new time value. Time changes remain in effect until the Ethernet Interface is powered-up or restarted. A typical *CHTIME* command is shown below:

```
= chtime 8:03
Time = 8:03:00.0
```

## CLEARCommand

The *CLEAR* command has the form:

```
CLEAR { EXS | LOG | TALLY | HEAP }
```

The *CLEAR* command sets various Ethernet Interface data structures to initial values, usually zeros.

- If the *CLEAR EXS* command is entered, the Extended Status Buffer is cleared to an initial state where only the 2 software versions are non-zero.
- If the *CLEAR LOG* command is entered, all log entries are discarded and the log is set to an empty state. The *CLEAR LOG* command also turns on the STATUS OK LED on the Ethernet Interface.
- If the *CLEAR TALLY* command is entered, all tallies are set to a value of zero, with the exception of the System Memory Tallies: TimReset and Restart and the PLC Driver Tallies: Regs, KbLogic, and uCode.
- If the *CLEAR HEAP* command is entered, the minimum system buffer free count values maintained by the STAT B command are reset to the current free count values.

A typical *CLEAR TALLY* command is shown below:

```
= clear tally
Tallies cleared
```

## CLSOSWCommand

### Notes

The changes made with either the Logicmaster 90 Configurator or the *CLSOSW* command will not take effect until the next Ethernet Interface restart.

The *CLSOSW* command clears the SOSW valid bit in the soft switches stored in the Ethernet Interface EEPROM. This ensures that the LAN controller board must receive new soft switch values before it can be restarted and put into service. On the next restart, if the Ethernet Interface is configured in the Series 90-70 PLC CPU then new soft switch values will automatically be accepted and saved in EEPROM. If the Ethernet Interface is not configured in the CPU, the Ethernet Interface will go into the Soft Switch Entry Utility after the completion of diagnostics. Refer to Appendix E for more discussion of the Soft Switch Entry Utility.

The *CLSOSW* command is shown below:

```
= clsosw
Updating, please wait ...
```

## DATE Command

The DATE command has the form:

```
DATE
```

This command causes the current system date to be displayed. This date is used in generating time stamps for MMS messages which require them. The initial value of the date is read from the PLC on Restart or, if unavailable, is set to 1-JAN-1989 on restart or power-up. The Modify command *CHDATE* can be used to set the date.

The DATE command is shown below:

```
> date
Date = 28-FEB-1990
```

## EXS Command

The EXS command has the form:

```
EXS
```

This command is used to display the Extended Status Buffer maintained by the Ethernet Interface software. The Extended Status Buffer maintains information about the service requests issued from the PLC ladder logic program. See Chapter 6 for a complete discussion of the form of the available service requests from the PLC ladder logic program. Also see Chapter 9 for more information on using the Extended Status Buffer information.

A typical EXS command is shown below:

```
> exs
<<< Extended Status >>>
Last command          8201 (2009H)
Last Sta Mgr cmd      0 (0000H)
Software version      100
PROM version          100
Error code            0 (0000H)
Last MDB in error    0000H 0000H 0000H 0000H 0000H 0000H 0000H 0000H
```

The number in parenthesis is the hexadecimal equivalent of the decimal value. See Chapter 9 for more details on Extended Status entries. The Extended Status Buffer can be cleared using the *CLEAR EXS* command.

## HELP Command

The HELP command has the form:

```
HELP      - or -      ?
```

The HELP command (or the single character command “?”) can be used to display a short reminder of the valid commands. If you are logged in to use modify commands, you will see the <<<Modify Commands>>> in the command list (see Table 4-2, “Modify Commands”). If you are not logged in, you will not see the modify command listing.

A typical HELP command when you are not logged in, ie, you are in Monitor level, is shown below:

```
> help
<<< Monitor Commands >>>
?      acb      bps      cap      date
exs    help    log      login    ltime    mdib
node   pi       rib      show     sosw     stat     tally
time   var      vmd
```

A typical HELP command when you are logged in is shown below:

```
= help
<<< Monitor Commands >>>
?      acb      bps      cap      date
exs    help    log      login    ltime    mdib
node   pi       rib      show     sosw     stat     tally
time   var      vmd

<<< Modify Commands >>>
chbps  chdate  chltime  chsosw  chtime  clear   clsosw
load   logout  net      ok       rem     report  restart
stopt  test    trace
```

## LOADCommand

The *LOAD* command has the form:

```
LOAD
```

The *LOAD* command causes the Ethernet Interface to enter the “load” state as described in Chapter 2, Installation Procedure 4: Configuring and Downloading a Station. After the *LOAD* command is entered, the module must have its software reloaded and reinitialized before any further processing may take place. Any data transfer between the Series 90-70 PLC and the network when the *LOAD* command is issued is permanently lost.

A typical *LOAD* command is shown below:

```
= load
Forcing software load
```

## LOGCommand

This command prints entries from the exception log. Log entries remain in the log until they are explicitly cleared by using the *CLEAR LOG* command or until they are overwritten by more recent data. The log is maintained as a circular list where new data overwrites the oldest data in the list. An arrow on the left points to the most recently logged event.

The LOG command has the form:

```
LOG
```

A typical LOG command is shown below:

```
> log
<<< Exception Log >>>
Date           Time           Event Count
01-FEB-1991    00:00:00.0    1H      1H    00H 0000H 0000H 0000H 0000H 0000H
01-FEB-1991    04:37:15.3    CH      14H   00H 000CH 0000H 0000H 0000H 0000H
```

The Date and Time columns contain a time stamp of the last occurrence of the logged event. The Event column identifies the internal software component that reported the exception. The following table lists the possible values for events. The Count column contains a repetition count for the event. If events which are identical occur regularly, they can easily flood the log and the PLC Fault Table with useless entries. Instead of recording each such repeated event in detail, the log simply keeps the time stamp of the latest and a count of the number of repetitions of the repeated event. The log Entry contains detailed information about the event. Refer to Chapter 9, Troubleshooting, for information on interpreting the logged events.

### Note

The timestamp used is the current day and time of day as known by the Ethernet Interface. This is the same time that is displayed by the *DATE* and *TIME* commands and changed by the *CHDATE* and *CHTIME* commands.

Table 4-9. Exception Log Event Definitions

Log Event	Cause
1	Powerup. A log entry of this event will appear every time the Ethernet Interface is restarted or powered up.
2	System events.
3	Network Layer events.
4	Transport Layer events.
5	Session Layer events.
6	Presentation Layer events.
7	Application Layer events.
8	PLC Driver events.
9	SRTP Service Agent events.
a	Invalid Message Definition Block (MDB) events.
b	MMS Service Agent events.
c	LLC events.
e	MMS Provider events.
10	Directory User Agent events.

## LOGIN Command

The LOGIN command has the form:

**LOGIN**

The LOGIN command will be followed by a prompt of the form:

**Password:**

You should enter your password (which will not be echoed). If the password matches the current password for the Modify level, you will receive a confirmation message and you will be allowed access to the Modify commands. If the password does not match, then an error message is displayed and the security level is not changed.

Please note that all characters which are typed after the password prompt except for the Enter key are assumed to be part of the password. Specifically, the delete and backspace characters do not have their usual meaning and are interpreted simply as password characters. Passwords are limited to 8 characters and all characters after the eighth are ignored. Unlike other inputs, the password does not need to be enclosed with double quotes to achieve case sensitivity.

The factory default password is: system (lower case).

### Note

There is a special variation of the LOGIN command that can only be used in conjunction with the *REM* (remote) command to login on a remote system. Refer to the *REM* command for a discussion of this variation.

---

## **LOGOUTCommand**

The *LOGOUT* command has the form:

```
LOGOUT
```

This command causes the secure login to be terminated. Any Modify commands entered after the logout will receive an error message. Logging out causes the login timeout value to return to 10 minutes. A typical *LOGOUT* command is shown below:

```
= logout  
Logged out
```

## **LTIME Command**

The *LTIME* command has the form:

```
LTIME
```

This command causes the current login timeout value to be displayed. A typical *LTIME* command is shown below:

```
> ltime  
Login timeout = 10 min
```

The login timeout value can be changed using the *CHLTIME* command.



## MDIB Command

The MDIB command has the form:

```
MDIB <page>
```

where <page> is an optional page number which defaults to 1

This command displays one page of information from the Local Application DIB (Directory Information Base). These are entries which have been configured for the station. Repeat the command for other pages if an expected entry is not found.

A typical MDIB command is shown below:

```
> mdib
<<< Application DIB >>>                                     Page 1 of 2
Comm name = "COMMON_NAME_1"
  APT obj  = { 1 2 1 }
  AE qual  = 0
  PSAP    = <<0001>>          SSAP    = <<000000000001>>
  TSAP    = <<0001>>
  NSAP    = <<0800190100f8fe>>
Comm name = "COMMON_NAME_2"
  APT obj  = { 1 2 2 }
  AE qual  = 0
  PSAP    = <<0002>>          SSAP    = <<000000000002>>
  TSAP    = <<0001>>
  NSAP    = <<0800190100f8fe>>
Comm name = "COMMON_NAME_3"
  APT obj  = { 1 2 3 }
  AE qual  = 0
  PSAP    = <<0003>>          SSAP    = <<000000000003>>
  TSAP    = <<0001>>
  NSAP    = <<0800190100f8fe>>
```

## NET Command

The NET command has the form:

```
NET { ON | OFF }
```

This command causes the MAC to either exit the token passing ring (when NET OFF is specified) or to attempt to re-enter the token passing ring (when NET ON is specified). This can be used to remove stations from the network without the need to physically disconnect them or restart the hardware.

A typical NET OFF command is shown below:

```
= net off
Interface off network
```

### Note

If the "lanonline" Soft Switch is set to NO, this command has no effect.

## NODE Command

The NODE command has the form:

```
NODE
```

This command causes the Ethernet Interface sign-on message to be printed out on the screen. When the Ethernet Interface is executing the Soft Switch Entry Utility, the reason that the utility was entered is also displayed.

A typical NODE command is shown below:

```
> node
IC697 PLC Factory LAN Interface
Copyright (c) 1990-1994. All rights reserved.
PROM version 1.14, Software version 1.13 MMS/Ethernet
MAC address = <<080019010177>>
Serial no. 01913826, MAC default = <<080019010177>>
```

## OK Command

This command causes the STATUS OK LED to turn ON. It has no effect on the contents of the exception log.

The OK command has the form:

```
OK
```

A typical OK command is shown below:

```
= ok
Display modified
```

## PI Command

The PI command has the form:

```
PI
```

This command displays the information regarding the MMS Program Invocation (PI) object currently defined for the station. A typical PI command is shown below:

```
> pi
<<< Program Invocation >>>
Pi = "PLC_Application", Deletable = 0, State = RUNNING
```

## REM Command

The *REM* command has the form:

```
REM <node> <cmd> [<cmd parms>]
```

where <node> is the MAC address of a remote GENet Ethernet Interface  
 <cmd> is any station manager command except REM  
 <cmd parms> is a list of any parameters required by <cmd>.

The *REMOte* command sends the Station Manager command which is its argument and any associated parameters to the node whose address is specified. The Station Manager on the remote node acts on the command as if it had been entered at its local serial port, but directs all output from processing the command back over the network to the station where the *REM* command originated. The results are displayed at the local station with the notation "REM" along with the prompt from the remote station to denote that the data was returned from the remote station. (A *REM* command cannot be issued to the node on which it is entered.)

A typical *REM* command is shown below:

```
= rem 08001901001f node
REM> IC697 PLC Factory LAN Interface
REM> Copyright (c) 1990-1994. All rights reserved.
REM> PROM version 1.14, Software version 1.13 MMS/Ethernet
REM> MAC address = <<08001901001f>>
REM> Serial no. 01393790, MAC default = <<08001901001f>>
REM> >
```

The LOGIN command is treated as a special case when it is specified in the *REM* command. The following command is used to login to a remote device.

```
REM <node> LOGIN <password>
```

Note that this prevents the prompt for the password value and displays the remote password in a readable form.

### Note

When using the *REM* command, the password should be placed in double quotes if it contains any uppercase letters because the password is case sensitive.

Security is enforced on the remote system just as if the command had been entered locally. Thus the remote user and any local users of a given node all see the same security level.

# REPORTCommand

The *REPORT* command has the form:

```
REPORT [<page>]
```

where <page> is an optional page number which defaults to 1

This command causes the current results of the most recent *TEST* command to be reported. It can be used to get intermediate reports for long running tests. Test results are maintained, and may be displayed until another test is started, or until the Modify security level is exited.

A typical *REPORT* command is shown below:

```
= report
<<< Test Results >>>                               Page 1 of 1
Command: test <<080019010021>> 1H 32H 0H NULL
Init node: <<08001901001f>>  Frames sent : 1H  Nodes responding :1H
Responding nodes   Response recd  Response w/ err  No Response
<<080019000121>>           1H              0H              0H
```

## Interpretation of Test Results

The line of output that begins “command: . . .” lists all the parameters that were specified (explicitly or implicitly) in the preceding *TEST* command, in the order <mode>, <cnt>, <sch>, <len>, <pat>. These numbers are displayed in hexadecimal regardless of how you entered them.

The line beginning “Init mode . . .” identifies the MAC address of the initiating node, how many test command frames it sent, and how many nodes responded.

Following this, there is a list (perhaps a list of one) of the responding nodes’ MAC Addresses with the corresponding number of test Responses received, Responses with error, and No Responses.

“Responses received” is the total number of responses received from that node. Frames containing CRC or other communication errors are not received but are discarded.

“Response with error” refers to frames that were received, ie, they were included in the count of “Responses received”, The initiating node compares the test data of all responses to the current test data (which always varies from the preceding frame because of the sequence number in the first byte position). Any received frame that does not compare is counted as a Response with error. The most common cause of this indication is that the <sch> parameter in the *TEST* command is set to too short an interval. This should be avoided by increasing <sch>. Also, some manufacturers’ products, while replying to the test command, do not return the data field; this will cause all their Responses received to also tally a Response with error.

“No Response” is computed as the difference between the number of test commands sent by the initiating node minus the number of Responses received from the subject node. This number of frames were “lost” either outbound from the initiator, inbound to the initiator, or internally (eg., lack of buffers) to either the initiator or responder.

## RESTART Command

The *RESTART* command has the form:

```
RESTART
```

The *RESTART* command causes the Ethernet Interface to be restarted without causing the software to be reloaded. It has the same effect as pressing the Restart pushbutton on the front edge of the Ethernet Interface quickly (2-3 seconds). Any data transfer between the Series 90-70 PLC and the network at the time the *RESTART* command is entered is permanently lost.

A typical *RESTART* command is shown below:

```
= restart
Restarting LAN Interface
```

## RIB Command

The RIB command has the form:

```
RIB [<page>]
```

where <page> is an optional page number which defaults to 1

This command displays one page of information from the Network Layer Routing Information Base (RIB). This gives the routing of NSAP's to Link Layer addresses. This routing information is maintained dynamically by the Network Layer ES-IS protocol. However, if static routing has been configured for this station on the GSM for a given NSAP, the static routing will take precedence.

A typical RIB command is shown below:

```
> rib
<<< RIB Table >>>                               Page 1 of 1
Dest NSAP      = <<08001901001234fe>>
First HOP NSAP = <<08001901001234fe>>
First HOP MAC Addr = <<08001901001234>>      First HOP LSAP = feH
Permanent Entry
Dest NSAP      = <<08001901001230fe>>
First HOP NSAP = <<08001901001230fe>>
First HOP MAC Addr = <<08001901001230>>      First HOP LSAP = feH
Permanent Entry
```

## SHOW Command

The SHOW command has the form:

```
SHOW { <parm name> | PARMS <task(s)> }
```

where <parm name> is the name of one of the configuration parameters from the tables included in the *CHSOSW* command and the *LOG* command.

or

PARMS is entered just as shown and

<tasks(s)> is a set of one or more task identifier letters from the Table 4-3.

The SHOW command has one of two forms. If the argument to the SHOW command is the string PARMS, then task identification letter(s) are also required. The list of configuration parameters for the specified task(s) is displayed.

A typical SHOW PARMS command is shown below:

```
> show parms t
<<< Transport Parameters >>>
tchksum      tflowctrl    tgiveup      tinactive    tlcack
tmaxpdu      treftime     trtrancnt    trtrantime   twindow
twindsize
```

If a configuration parameter name is entered with the SHOW command, the current value of that parameter is displayed. Valid configuration parameter names are listed in the tables below.

A typical SHOW command is shown below:

```
> show arespcnam
arespcnam = "Station_24_Responder"
```

## Configuration Parameters

Table 4-10. Configuration Parameters

Parameter	Description
	<b>ApplicationLayerConfigurationParameters</b>
alsap	LSAP for Application Layer APs
applaequal	Application Entity Qualifier for Application Interface AP
applapt	Application Interface AP object ID
applcnam	Common name for Application Interface AP
applpsap	PSAP for Application Interface AP
applssap	SSAP for Application Interface AP
arespaequal	Application Entity Qualifier for Responder AP
arespapt	Responder AP object ID
arespcnam	Responder AP common name
aresppsap	PSAP for Responder AP
arespssap	SSAP for Responder AP
assocappl	Maximum Number of associations to Application Interface AP
assocresp	Maximum Number of associations to Responder AP
	<b>SystemMemoryConfigurationParameters</b>
balloc1	Buffer pool 1 percent
balloc2	Buffer pool 2 percent
balloc3	Buffer pool 3 percent
balloc4	Buffer pool 4 percent
bbuff1	Buffer pool 1 buffer size
bbuff2	Buffer pool 2 buffer size
bbuff3	Buffer pool 3 buffer size
bbuff4	Buffer pool 4 buffer size
bremlsap	Remote command LSAP
brepri	Remote command priority
	<b>DataLinkConfigurationParameters</b>
ldrtry	Retry option
lgrpmsk0-7	Group RX addresses 0-7
lmacaddr	Station MAC address
lmaxdb	Maximum LLC buffer size
lrxringlen	Size of receive ring
ltxringlen	Size of transmit ring
lxidtime	XID frame response timeout
	<b>MMSProviderConfigurationParameters</b>
mmsacn	MMS Application Context Name
mmsacnobj	MMS Application Context Name Object ID
maltacn	MMS Companion Standard ACN
maltacnobj	MMS Companion Standard ACN Object ID
mmaxmsgsz	MMS Maximum Message Size

Table 4-10. Configuration Parameters - Continued

Parameter	Description
	<b>NetworkLayer Configuration Parameters</b>
nchksum	Checksumoption
ncfgtime	Configurationtimer
neslsap	LSAP for ALL-ES traffic
nesmac	MAC address for ALL-ES traffic
nhldtime	Hold timer
nislsp	LSAP for ALL-IS traffic
nismac	MAC address for ALL-IS traffic
nmaxpdu	Maximum NPDU length
noptmiz	Optimization option
npdulife	NPDU lifetime timer
npriority	Priority for NPDUs
nqwtime	Queue wait time
nsap	Station NSAP value
ntick	Timer tick count
	<b>PresentationLayer Configuration Parameters</b>
pacsepci	ACSE Presentation Context Identifier
pacsesynnam	ACSE Abstract Syntax name
pacsesynobj	ACSE Abstract Syntax object identifier
pmmspci	MMS Presentation Context Identifier
pmmssynnam	MMS Abstract Syntax name
pmmssynobj	MMS Abstract Syntax object identifier
pxferpci	Transfer Syntax Presentation Context Identifier
pxfersynnam	Transfer Syntax Abstract Syntax name
pxfersynobj	Transfer Syntax Abstract Syntax object identifier
	<b>SessionLayer Configuration Parameters</b>
stime	Session timer
stsap	TSAP
	<b>TransportLayer Configuration Parameters</b>
tchksum	Checksumoption
tflowctrl	Flow control timer
tgiveup	Give up timer
tinactive	Inactivity timer
tlack	Transport time between receiving TPDU and 2nd ack
tmaxpdu	Transport maximum TPDU size
treftime	Transport reference timer
trtrancnt	Transport maximum number of retransmissions
trtrantime	Transport retransmission timer
twindow	Transport window timer
twindsize	Transport receive window size
	<b>SRTP Service Agent Parameters</b>
vtsap	TSAP for SRTP communication
vdpsab	Disable DDP operation
vdptmout	Timeout for DDP duplicate name conflict
vdpretry	Max DDP resolve retries



## SOSW Command

This command displays the current setting of the Ethernet Interface Soft Switches or a message indicating that no Soft Switch values are defined. If not defined, the operator must set Soft Switch values, using the *CHSOSW* command, before the Ethernet Interface can proceed to any state beyond the Soft Switch Entry Utility.

The SOSW command has the form:

```
SOSW
```

A typical SOSW command is shown below:

```
> sosw
<<< Soft Switch Data >>>
MAC address = <<080019010177>> (Using default)
Load source = Serial
Network Online = Online after powerup
Backplane Online = Online after powerup
Networkload addr = <<090060000000>> (using default)
MMS Enable = Don't care
Pgm Enable = Don't care
```

## STAT Command

The STAT command has the form:

```
STAT <task(s)>
```

where <task(s)> is one or more task identification letters from Table 4-3

This command causes the current status of the task or tasks specified by the task identification letters to be displayed. An example STAT command is shown below:

```
= stat b
<<< System Memory Status >>>
Size   Alloc   Free   Min
----   -
28     651     474   469
60     237     186   185
380    254     240   235
1569   53      19    19
```

## STOPTCommand

The *STOPT* command has the form:

```
STOPT
```

This command causes an active *TEST* sequence to stop at its next iteration and to print the results of the terminated test. It is used to terminate a long running test before its completion.

A typical *STOPT* command is shown below:

```

= stopt
Test stopped by operator

=
of 1
<<< Test Results >>>
Command: test <<0800190100fb>> 100H 32H 0H NULL
Init node: <<08001901001f>>  Frames sent : 87H  Nodes responding : 1H
Responding nodes  Response recd  Response w/err  No Response
<<0800190100fb>>    87H           0H                0H

```

Page 1

## TALLY Command

The *TALLY* command has the form:

```
TALLY <task(s)>
```

where <task(s)> is one or more task identification letters from Table 4-3

This command causes the current value of the tallies for the specified task or tasks to be displayed. Some of these tallies simply indicate load and performance information about the station. Others can indicate whether or not there are problems either within the station or within the network. See Chapter 9, Troubleshooting, for more information on using the tallies to help isolate and resolve problems.

An example *TALLY* command is shown below:

```

> tally c
<<< PLC Driver Tallies >>>
PlcQFull = 0000H  PlcSweep = 03c9H  MsgRcv = 0038H  PLCReq  = 001aH
PlcAbt   = 0000H  MsgSent  = 0036H  MyAbt   = 0000H  Write   = 0023H
Read     = 0010H  Timeout  = 0000H  Regs    = 0400H  AnInput = 0040H
AnOutput = 0040H  uCode   = 0300H

```

Table 4-11. Application Layer Tallies (Tally a)

Tally	Meaning
UncSvSnt	Number of MMS unconfirmed services sent.
UncSvRcd	Number of MMS unconfirmed services received.
CanSent	Number of MMS Cancels sent.
CanRcvd	Number of MMS Cancels received.

**Table 4-12. System Memory Tallies (Tally b)**

Tally	Meaning
TimReset	Count of the number of times that the internal time and date have been changed. This tally is preserved over system restarts and software loads.
Restart	Count of the number of times that the Ethernet Interface has been re-started. This tally is preserved over the system restarts and software loads.

**Table 4-13. PLC Driver Tallies (Tally c)**

Tally	Meaning
PlcQFull	Count of the number of times an MMS request of the PLC was retried because of congestion in the PLC.
PlcSweep	Count of the number of executive windows received by the Ethernet Interface.
MsgRcv	Count of the number of messages received from the CPU.
PlcReq	Count of the number of COMM_REQs received from the application program.
PlcAbt	Count of the number of times the CPU aborted a data transfer.
MsgSent	Count of the number of times the CPU sent a message.
MyAbt	Count of the number of times the Ethernet Interface aborted a data transfer.
Write	Count of the number of times the Ethernet Interface successfully wrote to the Series 90-70 PLC memory.
Read	Count of the number of times the Ethernet Interface successfully read from the Series 90-70 PLC memory.
Timeout	Count of the number of times the Ethernet Interface timed out waiting for a response from the CPU.
Regs	Count of the number of registers configured in the PLC.
AnInput	Count of the number of Analog Input words configured in the PLC.
AnOutput	Count of the number of Analog Output words configured in the PLC.
uCode	The microcode revision level of the firmware in the Series 90-70 CPU.

**Table 4-14. Distributed Directory Protocol (DDP) Tallies (Tally d)**

Tally	Meaning
RegSnt	Number of DDP Register requests sent.
UnregSnt	Number of DDP Unregister requests sent.
RegRcv	Number of DDP Register requests received.
UnregRcv	Number of DDP Unregister requests received.
RslvSent	Number of DDP Resolve name requests sent.
RslvRcvd	Number of DDP Resolve name requests received.
RslvRsp	Number of Resolve name responses sent.
NameConf	Number of Name conflict advise indications received.
BrwseSnt	Number of Browse requests sent.
BrwseRcv	Number of Browse requests received.

**Table 4-15. ACSE Tallies (Tally e)**

Tally	Meaning
RejRcvd	A-Associate_Response(AARE) APDUs received indicating the association request was rejected with no reason specified or due to no common ASCE version.
RejSent	AARE APDUs sent rejecting an association request with no reason specified or due to no common ACSE version.
ARejRcvd	Total number of AARE APDUs received that rejected an association request.
ARejSent	Total number of AARE APDUs sent that rejected an association request.
AbrtRcvd	Number of Provider abort indications received.
AbrtSent	Number of Provider abort requests sent.
PAabort	Number of A-P-Abort indications sent.
PReject	Number of Presentation connections rejected by the Presentation service provider

**Table 4-16. Data Link Tallies (part of Tally I)**

Tally	Meaning
Unreg	Number of 802.3 frames received and discarded because the destination LSAP was not configured in the node.
Lsap0	Number of frames received and discarded because the destination LSAP had the value zero.
LsapOfI	Number of LLC service requests rejected due to lack of LSAP table space. A non-zero value in this tally indicates a Ethernet Interface system software error and should be reported to GE Fanuc Automation immediately.
EthUnreg	Number of Ethernet frames received and discarded because the destination Protocol was not configured in the node..
MacErr	A severe network fault prevented transmission of a frame for more than one second. See Exception Log, Event c, Entry 2 = 10b.
BufProb	A received LLC frame was lost due to the inability of the LLC software to acquire a system buffer. This may indicate a memory configuration problem or a temporary overload of traffic at the station.
UnrecPdu	Number of 802.3 frames received and discarded because the LLC control field is invalid.
TstRcvd	Number of test frames received.
TstResp	Number of test frame responses sent.
PadErr	Number of frames received which had a padding and the padding was more than 48 bytes.

**Table 4-17. MAC Layer Tallies (part of Tally I)**

<b>Tally</b>	<b>Meaning</b>
SQEErr	Number of times the SQE test failed.
MisdPack	The number of packets a receiver lost due to a lack of receive buffers.
FrameErr	The number of incoming packets that did not contain a multiple of eight bits.
SuccOne	The number of times a successful transmission was made with exactly one retry.
CrcErr	The number of incoming packets detected with a CRC error.
RbufErr	The number of times the next buffer was unavailable while receiving a chained data packet.
LateColl	The number of times a collision occurred after the slot time of the channel had elapsed.
LostCarr	The number of times the carrier was lost during a transmission.
BsyCarr	The number of times the transmitter had to wait because it sensed a busy carrier signal.
NoRtry	The number of times a successful transmission was made with no retries needed.
SuccMore	The number of times a successful transmission was made with more than one retry.
FRtry	The number of times the transmission failed despite using the maximum of 15 retries.

**Table 4-18. MMS Provider Tallies (Tally m)**

<b>Tally</b>	<b>Meaning</b>
MsgSent	Number of MMS PDU's sent.
MsgRcvd	Number of MMS PDUs received.
RejSent	Number of MMS Rejects sent.
RejRcvd	Number of MMS Rejects received.
RegFail	Number of times a registration with the communication service below failed.
BldFail	Number of MMS requests that the MMS Provider failed to encode.

**Table 4-19. Network Layer Tallies (Tally n)**

Tally	Meaning
DscGen	NPDUs discarded due to protocol error, syntax error, checksum error, duplicate option, incomplete NPDU, or reason not specified.
DscCong	Count of the number of packets discarded for inability to provide service.
DscAddr	NPDUs discarded due to destination NSAP unknown.
DscLife	Count of the number of packets discarded for transmit time exceeded.
DscUnsp	NPDUs discarded due to unsupported option(s).
DscReasm	NPDUs discarded due to segmented NPDU reassembly error.
PduRcvd	Count of the number of packets received.
PduSent	Count of the number of packets sent.
OctSent	Number of octets sent by this node.
OctRcvd	Number of octets received by this node.
EsEsSent	Number of ES-ES protocol NPDUs sent by this node.
EsIsSent	Number of ES-IS protocol NPDUs sent by this node.
EsEsRcvd	Number of ES-ES protocol NPDUs received by this node.
EsIsRcvd	Number of ES-IS protocol NPDUs received by this node.
EsEsErr	Number of (ES-ES protocol) ER NPDUs received by this node.

**Table 4-20. Presentation Layer Tallies (Tally p)**

Tally	Meaning
PCprRcvd	Number of CPR PPDUs received with no reason.
PCprSent	Number of CPR PPDUs sent with no reason.
CprTRcvd	Number of CPR PPDUs received with Transient Group.
CprPRcvd	Number of CPR PPDUs received with Permanent Group.
CprTSent	Number of CPR PPDUs sent with Transient Group.
CprPSent	Number of CPR PPDUs sent with Permanent Group.
ArpSent	Number of ARP PPDUs sent with no reason.
ArpErr	Number of ARP PPDUs sent with Error Group

**Table 4-21. Session Layer Tallies (Tally s)**

Tally	Meaning
RfRcvd	Refuse (RF) SPDUs received with no reason specified.
RfSent	RF SPDUs sent with no reason specified.
RfPRcvd	RF SPDUs received because of unknown SSAP or proposed protocol version not supported.
RfPSent	RF SPDUs sent because of unknown SSAP or proposed protocol version not supported.
RfTRcvd	RF SPDUs received because of no user attached to SSAP or congestion.
AbRcvd	{RESET TO 1}Count of the number of aborts received.
AbSent	Count of the number of aborts sent.
AbPSent	Count of the number of aborts sent because of protocol errors.

**Table 4-22. Transport Layer Tallies (Tally t)**

<b>Tally</b>	<b>Meaning</b>
CrCong	Incoming connections refused due to congestion.
CrConfg	Incoming connections refused due to negotiation failure, reference number problems, or addressing problems.
CrRefCfg	Incoming connections refused due to negotiation failure, reference number problems, or addressing problem.
CrProErr	Incoming connections refused due to protocol error:
CrUnsuc	Timeouts waiting for connection confirm, or outgoing connections refused due to protocol error:
PduProEr	Invalid TPDU's (other than Connect Request) received.
PduRefP	Disconnect Request or Error TPDU's received in response to a TPDU (other than a Connect Request) sent from local node.
ChkFail	Incoming TPDU's with bad checksum fields.
Timeout	Timeouts waiting for a response to a TPDU which was sent.
PduSent	Count of the number of TPDU's sent.
PduRcvd	Count of the number of TPDU's received.
ReTrans	Count of the number of TPDU's re-sent.
CrdtZero	Number of Acknowledgement TPDU's sent that reduced the foreign credit to zero.
OpenCon	Count of the number of open connections.

**Table 4-23. SRTP Service Agent Tallies (Tally v)**

<b>Tally</b>	<b>Meaning</b>
PDUsent	Total Number of SRTP PDU's sent.
PDUrcv	Total Number of SRTP PDU's received.
ConnRq	Number of SRTP Connection requests received.
ConnRsp	Number of SRTP Connection responses sent.
DataReq	Number of SRTP Data request PDU's received.
DataRsp	Number of SRTP Data response PDU's sent.
DataErr	Number of SRTP Data error PDU's sent.
AsyncReq	Number of SRTP Asynchronous request PDU's sent.
BadPDU	Number of Unrecognizable SRTP PDU's sent.
DiscPDU	Number of SRTP PDU's that were discarded.

## TESTCommand

The *TEST* command has the form:

```
TEST { <node> | ALL } [<cnt> [<sch> [<len> [<pat>]]]]
```

where <node> is a destination MAC address and ALL is a synonym for the broadcast address, ffffffff.

<cnt> is an optional number specifying the number of test frames to be sent, which defaults to 1.

<sch> is an optional number of 10 millisecond time intervals between consecutive test frame outputs. The default value for this parameter is 50 (500 milliseconds or 1/2 second). This parameter's value can range from 0 to 7fffH (32767), or about 6 minutes. A value of 0 for this parameter results in the default value of 50 being used.

<len> is an optional length of user data in the test frame which defaults to 0 (no data in the test frame). The range of values for this parameter is from 0 to the value of configuration parameter maxdb - 16. The test frame data length may be further modified by the <pat> parameter, as described below.

<pat> is an optional value to be used as the data pattern in the user data. This parameter's value can range from 0 to ffH (255). If a value is supplied for the <pat> parameter, each test frame will contain <len> bytes of data, and each byte of test data will be <pat>. However, if the <pat> parameter is omitted and a non-zero <len> value is supplied, a special testing byte sequence is used. In this test sequence, successive test frames are sent with an alternating data pattern (00H, 55H, aaH, ffH, and a counting pattern) and an incremental frame length of 1 byte up to <len> bytes.

For example, the data for the first six test frames would consist of:

```
00H (len = 1)
55H 55H (len = 2)
aaH aaH aaH (len = 3)
ffH ffH ffH ffH (len = 4)
00H 01H 02H 03H 04H (len = 5)
00H 00H 00H 00H 00H 00H (len = 6)
```

This command causes one or more LLC test frames to be sent to the specified address. Test frames are output at frequency <sch> until <cnt> frames have been sent. The optional <len> and <pat> parameters can be used to specify the form of user data sent on the test frames. A lengthy *TEST* command can be terminated by using the *STOPT* command.

**Caution**

**Care should be exercised in invoking the TEST command on a network in a production environment. Invoking the TEST command increases the load on all nodes, especially the initiating node. Be especially cautious if you are using values of <sch> smaller than the default, or values of <len> larger than the default. Also, be careful if you are using the ALL synonym, which broadcasts to all nodes in the network.**



The *TEST ALL* command can be used to return a list of all the other stations on the network. For the MAP Interface, the output from the *TEST* command shows the token passing order of stations in the logical ring.

The results of the last *TEST* command are maintained until the Modify security level is exited (either by a timeout or by the *LOGOUT* command). Also, the *REPORT* command can be used to view the results of a test which has been completed or the current results of a test in progress.

A typical *TEST* command is shown below:

```

Page 1 of 1
= test 0800190100fb 100H
Test initiated

=
<<< Test Results >>>
Command: test <<08001901001f>> 100H 32H 1H ALT
Init node: <<08001901001f>>  Frames sent : 100H  Nodes responding : 1H
Responding nodes  Response recd  Response w/err  No Response
<<0800190100fb>>      100H          0H              0H

```

## TIME Command

The *TIME* command has the form:

```
TIME
```

This command causes the current system time to be displayed. This time is used in generating time stamps for messages which require them. This time is also used as a time stamp for events in the exception log displayed by the *LOG* command. The initial value of the time on restart, power up, or load is read from the local PLC CPU. If this is not available, it is set to 00:00:00.0 (midnight). Time values are based on a 24 hour clock. The Modify command *CHTIME* is used to change the time value.

A typical *TIME* command is shown below:

```

> time
Time = 15:46:02.3

```

# TRACECommand

The *TRACE* command has the form:

```
TRACE {<task(s)> [<minutes> [<len_ref>]] | !}
```

where <task(s)> is one or more task identifier letters from Table 4-3 or “z” to add PDU trace.

<minutes>is an optional parameter that specifies how long *TRACE* will remain active. Default is 10 minutes. This parameter is a character string that specifies an integer which can be 0, or a value from 1 to 32767. If 0 is specified then time out is not enforced. Any non-zero value specifies the duration in minutes after which the trace activity will automatically cease. Login will be maintained (automatic logout will be inhibited) until after the trace has terminated.

<len\_ref> is an optional parameter that limits the amount of PDU (z) data to be displayed. The PDU display format is a character string that specifies an integer value ranging from 1 to 32767. If omitted from the command line, the value 48 will be substituted. This parameter provides the flexibility to view the PDU in its entirety or just a portion of it. Since each line of display consists of 16 bytes, and, if truncating of the PDU does take place (always at the end of a line and trailed by ‘...’ on the next line), the actual number of bytes displayed will be rounded up to the next multiple of 16 from <len\_ref>. There is, of course, a performance penalty for displaying large PDUs when they occur frequently.

The identifier “!” disables all tracing and should only be used by itself.

This command causes a diagnostic trace of the specified task or tasks to be displayed at the terminal where the *TRACE* command is invoked. This trace information shows each protocol exchange at the selected task and can be used by protocol experts to diagnose problems at the node or in a remote host.

The format of the display is the same at both the local and the remote terminal.

The *TRACE* command issued last, either locally or remotely, determines where the display takes place.

Tracing of the Data Link layer (l) is not allowed if the *TRACE* command is issued at a remote terminal.

**Caution**

**Enabling trace output has severe performance penalties for the communications software. This command should only be used in debugging problems. It should NEVER be left enabled in operational nodes.**

The trace output is enabled for only the tasks specified with the most recent *TRACE* command; trace output is disabled for all tasks not specified.

Trace output is generated by the selected tasks until either the *TRACE* command is issued again, to disable tracing or to select a new set of tasks, or the timeout specified for the *TRACE* command has expired. The command, *TRACE*, with no arguments, shows what tasks are currently printing trace information, the time remaining for an active trace, and the active *len\_ref* value. The command, *TRACE !*, causes all tracing to be disabled.

### Caution

**Once trace has been initiated from a remote Station Manager, trace output continues to be sent to that remote Station Manager until terminated as described above. Trace output continues even if the remote Station Manager is disconnected or logged into another station. Be sure to stop your traces.**

Detailing the interpretation of the trace data is beyond the scope of this document. It requires expertise in the internal operation of the OSI protocols that is not needed by most users of the network.

A typical *TRACE* command is shown below:

```
= trace mz
Trace enabled for: mz
minutes remaining  = 10
len_ref           = 48
```

If you attempt a trace of the Data Link layer when it is not allowed, a response similar to the example above will be displayed, then followed by the message:

```
Trace not allowed for Data Link layer in remote mode.
```

If other task letters were also specified in addition to the disallowed Data Link layer task, the trace will be executed for them.

## VAR Command

The VAR command has the form:

```
VAR [<page>]
```

where <page> is an optional page number which defaults to 1

This command displays one page of VMD specific MMS named variables starting at the specified page. Variable object attributes includes the variable name, its associated data type, type size, base address, etc. See the Variable Names Screen in Chapter 3 for details.

A typical VAR command is shown below:

```
> var
<<< VMD Specific Variable Names >>>                Page 1 of 1
Variable Name      Data Type Reference          Bit
Type Size         Pfx Locat      Count Off  Array
"VARIABLE_NAME_1"  09  10H   %R 0001H      20H 0H   0
"VARIABLE_NAME_2"  09  10H   %R 0021H      20H 0H   0
"VARIABLE_NAME_3"  09  10H   %R 0041H      20H 0H   0
```

## VMD Command

The VMD command has the form:

```
VMD
```

This command displays the current state of the MMS Virtual Manufacturing Device (VMD). A typical VMD command is shown below:

```
> vmd
<<< VMD Status >>>
VMD Logical Status = STATE-CHANGES-ALLOWED (0)
VMD Physical Status = OPERATIONAL (0)
```

# Chapter 5

## *General PLC Application Programming*

---

---

This chapter contains general information on ladder logic programming for the Series 90-70 GENet Ethernet Interfaces. The following topics are discussed in this chapter:

- Commands supported through PLC ladder logic
- Programming COMMunication REQuests
- The COMM\_REQ Status Word (CRSW)
- The LAN Interface Status Word (LISW)

### **Commands Supported Through Ladder Logic**

There are two types of commands supported through the Series 90-70 PLC ladder logic: communications commands and Station Manager commands.

#### **Communications Commands**

It is not necessary to perform any ladder logic programming if your Host Computer initiates all communications, i.e., if only the Responder Application Process is used on the GENet Ethernet Interface. However, if you wish to initiate communications to other MMS devices from the Series 90-70 PLC, you will need to know how to program these functions. See the beginning of Chapter 6 and Appendix B for a discussion of “Application Processes”.

The Communications commands provide the communications services between the PLC ladder logic and a remote station. The application interface initiates communications services using the COMM\_REQ command in the ladder logic program. See Chapter 6 for a complete description of each communication command available for the Ethernet Interface.

## Station Manager Commands

The Station Manager Ladder requests allow the ladder logic application within the PLC to retrieve some of the same management information that is available through the Station Manager. There are four Station Manager ladder requests.

- Retrieve Extended Status Buffer Request
- Retrieve Tallies Request
- Retrieve Log Events Request
- Restart Ethernet Interface
- Refer to Chapter 7 for a complete description of the COMM\_REQs for these requests.

## Programming COMMunication REQuests

A number of terms are used throughout this manual which have special meaning. *Command* refers to a ladder logic instruction to the Ethernet Interface. Series 90-70 PLC ladder logic commands use the COMMunication REQuest (COMM\_REQ), and a block of words called the Message Definition Block (MDB) to communicate with the Ethernet Interface.

To successfully program communication commands you must understand how to perform each of the following steps.

1. Program the COMM\_REQ instruction.
2. Program the COMM\_REQ Function Block.
3. Use the COMM\_REQ Status Word and the LAN Interface Status Word to monitor the status of the COMM\_REQ commands, of the Ethernet Interface, and of the LAN.

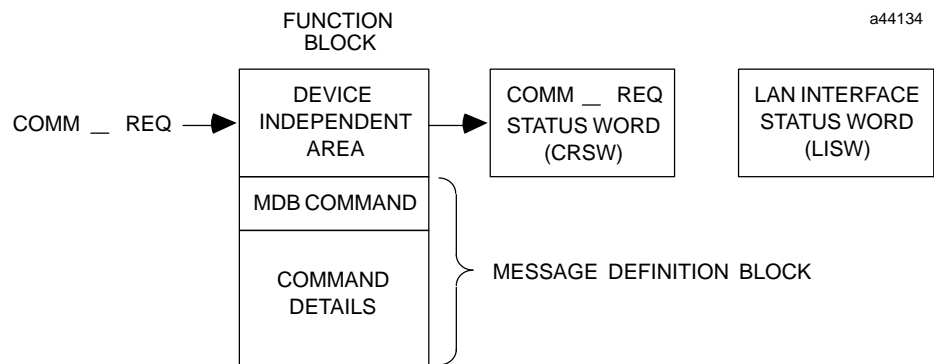

Figure 5-1. General Format for COMM\_REQs

## Using the COMM\_REQ Instruction

The COMMunication REQuest (COMM\_REQ) ladder instruction opens a window between the Series 90-70 PLC CPU and the Ethernet Interface. Information in the Message Definition Block (MDB) is transferred from the PLC CPU to the Ethernet Interface while the window is open.

The COMM\_REQ function block has two parts: Device Independent Area (DIA) and the Message Definition Block (MDB).

### Device Independent Area

The Device Independent Area provides information about the Message Definition Block (MDB), COMM\_REQ Status Word (CRSW), and timing for the COMM\_REQ. The table below shows the Device Independent Area format.

**Table 5-1. Format of the COMM\_REQ Device Independent Area**

Description	Word Offset	Value
Word Length of MDB	0	1 - 128
Wait/NoWait Flag	1	0 (No Wait)
CRSW, Memory Type	2	(See Below)
CRSW, Offset	3	0 - Max Configured
Idle Timeout Value	4	0
Maximum Communication Time	5	0

**Word Length of MDB** - The first word of the Device Independent Area indicates the word length of the MDB. An MDB with a command word and no parameters has a word length of one (1).

**Wait/No Wait Flag** - This word must be set to 0 (= No Wait). There is an internal protocol between the Series 90-70 CPU and the Ethernet Interface. Setting this flag to “Wait” would cause additional overhead (an extra message sent from the Ethernet Interface to the CPU) to assure the CPU that the MDB got to the Ethernet Interface within a certain time limit. A conscious design decision was made to avoid this overhead. The COMM\_REQ will not work properly with an ethernet Interface unless the “No Wait” flag (value of zero) is specified.

**CRSW, Memory Type** - The CRSW Memory Type and Offset fields of the Device Independent Area define the location of the COMM\_REQ Status Word. The CRSW is a 16-bit field used by the Ethernet Interface to provide the status of its associated COMM\_REQ instruction to the ladder logic program. The CRSW Memory Type field specifies the PLC memory type for the status area (see the table below for valid types).

Table 5-2. Values for the CRSW Memory Type

Code		Memory Type
Decimal	Hexadecimal	
8	08	%R - Register Table
10	0a	%AI - Analog Input Table
12	0c	%AQ - Analog Output Table
16 or 70	10 or 46	%I - Discrete Input Table
18 or 72	12 or 48	%Q - Discrete Output Table

**CRSW, Offset** - The CRSW Offset field specifies the offset into the memory type. Note that the CRSW Offset is zero based. For example, segment 8 offset 0 corresponds to %R1.

The CRSW will have one of the values listed in the table below.

Table 5-3. CRSW Interpretation

CRSW Value	Value Interpretation
80H	COMM_REQ has been received and is being processed
40H	COMM_REQ has completed without error
20H	COMM_REQ has completed with error

If the CRSW memory type/offset is invalid, the Ethernet Interface cannot indicate whether the command in the MDB succeeded or failed.

**Idle Timeout Value** - This field is not used when the “No Wait” flag is specified.

**Maximum Communication Time** - This field is not used when the “No Wait” flag is specified and should be set to 0.

## Message Definition Block

The Message Definition Block (MDB) is a contiguous block of (word-oriented) memory containing detailed information about the COMM\_REQ command to be executed. It always starts at word offset 6 from the start of the COMM\_REQ. It will have at least one word, containing the command number. Other information in the MDB will vary for each command.

Refer to Chapter 6 for a description of the MDB format for communication commands. Refer to Chapter 7 for a description of the MDB format for Station Manager commands.



## Programming a COMM\_REQ

The following ladder logic example shows how a typical COMM\_REQ instruction is programmed.

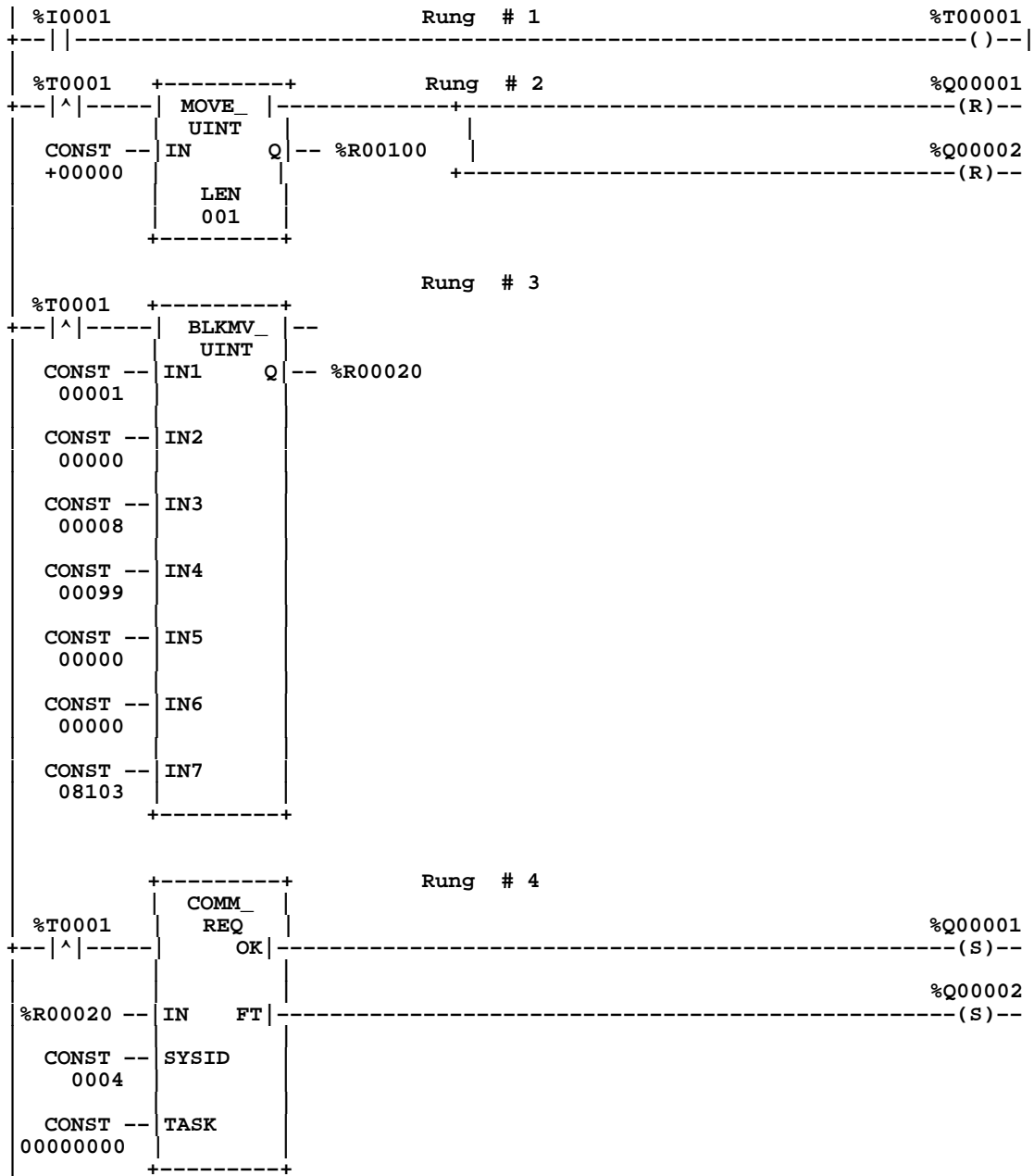

**Rung # 1:** Input %I1 triggers %T1, which enables execution of the MOVE and COMM\_REQ instructions. T1 is used as a positive transition contact, executing once when %I1 transitions from OFF to ON.

**Rung # 2:** The MOVE\_UINT instruction moves a zero to the CRSW referenced in the COMM\_REQ (see rung #3). This clears the CRSW. This rung also resets the outputs used to denote OK or FT (fault) by the COMM\_REQ function block in rung #4.

It is recommended that the CRSW be cleared and the COMM\_REQ outputs be cleared each time before issuing a COMM\_REQ.

**Rung # 3:** The BLKMOV\_UINT instruction sets up the COMM\_REQ parameters. When the rung is activated, the seven (7) constant operands are moved into the memory beginning at the address indicated in the instruction (%R20 in this example). The constant operands in this example are defined below:

**Table 5-4. Block Move Instruction Operands**

BLKMOV_UINT Parameter	Loaded Memory Word		Description
	Address	Value	
IN1	%R20	00001	The MDB length is one word.
IN2	%R21	00000	Flag must be set to "No Wait".
IN3	%R22	00008	The Status Area is in the Register Table.
IN4	%R23	00099	The Status Area is at %R100 (offset 99 into the Register Table).
IN5	%R24	00000	Not used because of "No Wait" flag.
IN6	%R25	00000	Not used because of "No Wait" flag.
IN7	%R26	08103	The Ethernet Interface command being sent is a "Restart LANInterface Request". This is the first word of the MDB.

In this example, the MDB is one word long (containing the command number 8103). For MDBs that have parameters (and, therefore, are longer than one word), multiple BLKMOV\_UINT instructions are required.

**Rung # 4:** The COMM\_REQ instruction has 3 input parameters

- The IN field points to the starting location of the COMM\_REQ parameters (%R20 in this example).
- The SYSID field of the COMM\_REQ defines the target rack and slot of the Ethernet Interface for the COMM\_REQ. The first two digits of SYSID (00 in this example) indicate the rack number, the last two digits (04 in this example) indicate the slot number of the Ethernet Interface. It is required for all COMM\_REQ instructions.
- The TASK field of the COMM\_REQ indicates which mailbox task ID to use for the specified rack and slot. This field should always be zero (0) for the Ethernet Interface.

The COMM\_REQ has two, mutually-exclusive, outputs: OK (%Q1 in this example) and FT (%Q2 in this example). The OK output is turned on if the COMM\_REQ was successfully sent to the Ethernet Interface. The FT output is turned on if there were problems in processing the COMM\_REQ. If the FT is ON, it usually indicates that there are invalid data in the Device Independent Area of the COMM\_REQ. It may also indicate that the 7-message VME mail input queue on the Ethernet Interface is full.

---

## The LAN Interface Status Word

The status of the Ethernet Interface and the LAN is reflected in sixteen (16) dedicated bits, which are updated by the Ethernet Interface once per scan. These sixteen bits are collectively referred to as the LAN Interface Status Word (LISW). Table 5-7 defines each of these bits. More detailed information about the status of the Ethernet Interface software can be requested by the ladder logic program using the Station Manager commands described in Chapter 7.

### Note

The LAN Interface Status Word and the COMM\_REQ Status Word (CRSW) are not the same. The CRSW status area indicates whether the COMM\_REQ completed successfully. The LISW provides status information about the Ethernet Interface and the attached network.

### Location of the LAN Interface Status Word

Each Ethernet Interface must be assigned a unique location for its LAN Interface Status Word (LISW). The location of the LISW for a given Ethernet Interface is determined in the Logicmaster 90-70 Configurator package. The LISW location is set when you configure the slot for an Ethernet Interface.

The Logicmaster 90-70 Configurator will default to the lowest numbered 16 bits in the discrete input table (%I) that have not already been claimed. Bits within any table are allocated in the order the slots are configured. For example, if a Genius input module is configured for slot 6 with 1024 bits from the discrete input table (%I1 through %I1024), an ethernet Interface added to the configuration will have its LISW location default to %I1025 through %I1040. This mechanism prevents overlap of a given area of memory.

## Contents of the LAN Interface Status Word

**Caution**

**Unless the “LAN Interface OK” bit is set (as described in the following table), the other status inputs are invalid.**

Table 5-5. The LAN Interface Status Word

Bit Offset	Definition	Description
16	LANInterface OK	This bit is set to 1 by the Ethernet Interface software at the end of every window. If the Ethernet Interface cannot access the PLC, the CPU will set this bit to 0.
15	InitiateIndication Pending	This input is set to 1 when a remote station on the network requests to initiate an association with the local application program. This input remains 1 until the remote station gives up (aborts the attempt), or until the local application program responds to the Initiate Indication with a Positive or Negative Initiate Response. If multiple (more than 1) Initiate Indications are pending, this input will remain 1 until all of the pending indications have either been aborted or responded to. Otherwise this bit is 0.
14	Resource Problem	This input is set to 1 whenever the Ethernet Interface software experiences a resource problem (i.e., lack of data memory). Once set to 1, this bit is not cleared until the Ethernet Interface is restarted. The Ethernet Interface may or may not be able to continue functioning, depending on the severity of the problem. Use the Station Manager <i>STAT B</i> and <i>LOG</i> commands to understand the problem. See Chapter 9, Troubleshooting, for further information.
13	LANOK	This input will be held at the value 1 as long as the Ethernet Interface software is able to communicate on the network. If the network should become inaccessible from this station, due either to local or network problems, this input will be set to 0.
12	Network Memory Access	This input is set to 1 when a remote station on the network reads or writes data in the memory of the local PLC using the MMS Responder communication services. This input will be held high for at least one full PLC scan and then it will be set to 0.
1 - 11	Reserved	

---

## General Tips on Ladder Programming

1. Make sure LISW bit 16 is ON before issuing a COMM\_REQ.
2. If you issue a COMM\_REQ to communicate on the network, make sure LISW/13 is ON.
3. Check the COMM\_REQ OK/FT bits to make sure the command arrived at the Ethernet Interface.
4. Wait for the COMM\_REQ Status Word to be set to 0x20 or 0x40 to know if the Ethernet Interface was capable of processing the command.
5. If you are attempting to communicate with a remote station, wait for its response before issuing additional COMM\_REQs.

# Chapter 6

## *MMS COMMunications REQuests*

---

---

This chapter provides an overview of the OSI Application Layer used by the GENet Ethernet Interface. It also provides the detailed information you need to program the communications services for your Ethernet Interface in the event that you wish to initiate communications from the Series 90-70 PLC. No PLC programming is required if initiation of services is by a remote host.

### OSI Reference Model

The communication services used by the Series 90-70 Ethernet Interface is based on the Open Systems Interconnection (OSI) Reference Model developed within the International Standards Organization (ISO). This section provides an overview of the OSI Application Layer and the message flow that occurs when two devices are communicating over the LAN. Refer to Appendix B for more information about the OSI Reference Model.

### OSI Application Layer

The OSI model is “connection-oriented”. This means that stations on a network can only transfer information after establishing a logical connection, much like two people using the telephone system. These connections are called “associations”. The association, like a telephone conversation, can be initiated and concluded by either party. Associations are allowed between two parties only. There are no “conference calls”. However, each GENet node may have up to a total of eight separate associations active at one time.

The “parties” connected by an association are called “Application Processes” (APs). Each AP has a name, called an Application Common Name. The Series 90-70 Ethernet Interface defines two APs which are used to perform communications services:

- MMS Responder
- Application Interface

Both the MMS Responder and Application Interface use the Manufacturing Message Specification (MMS) to define the communication services available for the Series 90-70 PLC. MMS is an international standard for defining the communication services used by manufacturing devices.

## Message Flow in the OSI Model

The OSI model uses four types of messages to describe the flow of data into and from the Ethernet Interface. They are: *request*, *indication*, *response*, and *confirmation*. Figure 6-1 is a time sequence diagram showing the relationship of the message types. As time progresses, Station A sends a *request* message. This same message is carried by the LAN to Station B where it is received as an *indication*. Station B then formulates and sends an appropriate *response* message. This message is carried by the LAN to Station A where it is received as a *confirmation*.

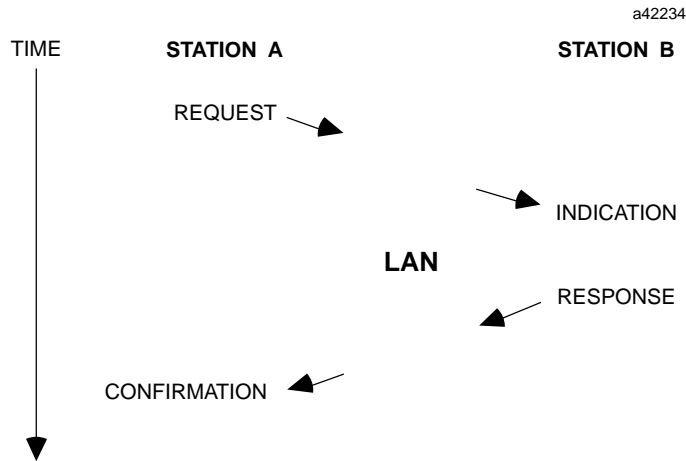

Figure 6-1. Message Types, Time Sequence

Response/confirmations can indicate either success or failure of processing the request/indication. If processing was successful, the response/confirmation is termed a positive response/confirmation. If the request service was not performed due to some error, a negative response/confirmation is returned.

## Series 90-70 Ethernet Interface Application Processes

As stated before, the Series 90-70 Ethernet Interface provides two Application Processes (APs), MMS Responder and Application Interface, to perform communications services using the Manufacturing Message Specification. The MMS Responder AP responds to remote device requests, but cannot issue MMS commands. The Application Interface AP can respond to or initiate MMS commands. Ladder programming is required to take advantage of the Application Interface.

### MMS Responder

The MMS Responder AP supports the MMS Services that do not require Series 90-70 ladder logic. No programming of the local PLC is necessary to use the MMS Responder services.

The MMS Responder AP responds to remote device requests for association services, read/write access, and start and stop of the PLC ladder program. The MMS Responder AP provides the following services:

- Responder association services
- Start, Stop, Reset, and Resume the Series 90-70 PLC ladder program
- Read and Write of the Series 90-70 PLC memory and I/O
- Response to various MMS requests for configuration information such as Identify, Status, GetNameList, and GetCapabilityList

With the MMS Responder functions, the Ethernet Interface processes indications from another (remote) station. These indications are initiated by the remote application program, and the responses to them (if any) are sent from the local MMS Responder back to the remote application program.

The PLC ladder program gets an indication in the LAN Interface Status Word when external reads or writes occur via the MMS Responder. The use of this indication by the PLC ladder program is optional.

The MMS Responder has the ability to handle user-defined Variable Names. Named Variables are defined in the configuration file produced by the user on the GSM and downloaded to the Ethernet Interface. Remote access to memory in the MMS Responder station may be through variable names or addresses.

## Application Interface

The Application Interface AP supports the MMS services that require PLC ladder logic. The Application Interface AP allows the Series 90-70 PLC ladder program not only to respond, but also to initiate requests to remote devices.

The Application Interface serves as a provider of MMS services between the ladder program and the remote Application Process.

The Application Interface provides the following client services:

- Define Application Service
- AssociationServices (Initiate, Conclude, and Abort)
- Read, Write, and Information Report Services
- Status, Unsolicited Status, and Identify Services
- Start, Stop, Reset, and Resume Services
- Cancel Message Services



## Selecting the Application Process

The GENet Series 90-70 PLC Ethernet Interface allows two separate Application Common Names to be defined, one for each Application Process. Example Application Common Names are shown in the table below.

The Application Process used on an association will be the one whose Application Common Name was used when the association was initiated.

Associations originating from the local PLC ladder program are always from the Application Interface AP.

**Table 6-1. Example Application Common Names**

Application Process	Station Manager Parameter	Example Name
MMSResponder	arespcnam	CELL_16_PLC
ApplicationInterface	apclnam	MATERIAL_IN

Using the example Application Common Names from the table above, a remote application would choose the Application Process in the Series 90-70 PLC as shown below:

- MMS Responder: An association from a remote Application Process (AP) to “CELL\_16\_PLC” will use the MMS Responder services of the Ethernet Interface.
- Application Interface: An association between “MATERIAL\_IN” and a remote AP will use the Application Interface.

The Series 90-70 PLC ladder program or GSM Configuration Editor may define the Common Name for the local Application Interface Application Process. The MMS Responder Common Name can only be changed via a GSM configuration change.

The Ethernet Interface can simultaneously maintain a total of up to eight associations. The possible associations may be normally user-limited to fewer than 8 on either or both of the two APs, using the configuration parameters *assocresp* and *assocappl*. The default for each is 8 (though only a total of 8 across both APs is permitted).

Refer to Appendix F for a complete list of the configuration parameters with an explanation of the use for each parameter.

## Programming Communications COMM\_REQs

Programming is required only for the Application Interface AP. You should read and understand Chapter 5 on the PLC COMM\_REQ instruction before continuing.

The specific commands necessary for programming the MMS services are described below. Before describing the message services in detail, some command notation will be explained.

- Most COMM\_REQs include a pointer to an “Association Control Block (ACB)”. The ladder program must assign a unique 5-word ACB for each active association. The ACB location is assigned by the ladder when it establishes the association and is thereafter used to tell the Ethernet Interface on which association the various COMM\_REQs apply.
- When a parameter in a COMMunications REQuest (COMM\_REQ) requires multiple consecutive words, the “Word Offset” entry in the COMM\_REQ description will show the range of word offsets covered by this parameter. The lower and upper end of this range will be separated by a dash (“-”). For example, refer to Table 6-4 (Initiate Request COMM\_REQ), the Length of Application Context Name parameter.
- The Invoke ID parameter is a number provided by the ladder program and used by the local and remote APs to be sure they are talking about the same request. No two outstanding messages on a given association may have the same Invoke ID or an error will result.
- The COMM\_REQ command description tables have been sectioned into seven-word increments as indicated by a horizontal line across the word number and value fields. This shows the words that would appear together in a block move instruction in building the COMM\_REQ. This indicator is provided as a programming convenience only, and does not have any significance to the parameters.
- Character strings must be packed into Series 90-70 PLC words in reverse order. This will allow the character string to be displayed properly in the character Register Reference Table display of the Logicmaster 90 Programmer. Example: ASCII characters “GE” would correspond to a register having the contents 17735 (4547H) or “EG” ASCII.

This chapter describes the specific commands available for programming the Manufacturing Message Specification (MMS) services used by the Application Interface AP.

The MMS services available through the ladder program are listed in the PLC Communication Command table (Table 6-2). The table contains information which identifies the specific service type associated with the corresponding command number. Command codes in the ACTION column are: L - Local, S - Send, R - Receive.

- Some of these PLC commands are processed *locally* with no message sent to the remote station. These commands are of the form: Define ... or Examine ...
- Other PLC commands are used to *send* either a request or response MMS message. These commands are of the form: ... Request or ... Response.
- Still other PLC commands are used to *receive* either an indication or confirmation MMS message. These commands are of the form: Examine ... Indication or Examine ... Confirmation.

Commands with an entry “S/L” in the ACTION column (Table 6-2) are used to send a MMS request or response if the OSI 7-Layer or Explicit miniMAP context (MAP Interface only) is being used. Those same commands used with the Implicit miniMAP context (MAP Interface only) are processed locally.

Table 6-2. PLC Communications Commands

PLC Communication Command	Command Number		ACTION
	(DEC)	(HEX)	
DefineApplication	8200	(2008)	L
InitiateRequest	8201	(2009)	S/L
ExamineInitiateIndication	8202	(200A)	R
InitiateResponse	8203	(200B)	S/L
ExamineInitiate Confirm	8204	(200C)	R
ConcludeRequest	8205	(200D)	S/L
ConcludeResponse	8206	(200E)	S/L
AbortRequest	8207	(200F)	S/L
IdentifyRequest	8240	(2030)	S
StatusRequest	8250	(203A)	S
StatusResponse	8251	(203B)	S
UnsolicitedStatusRequest	8252	(203C)	S
ExamineUnsolicitedStatusIndication	8253	(203D)	R
Cancel Message Request	8290	(2062)	S
ExamineAssociationOptions	8300	(206C)	L
Get Remote Name List	8301	(206D)	S
Start Request	8304	(2070)	S
Examine Start Indication	8305	(2071)	R
Start Response	8306	(2072)	S
Stop Request	8307	(2073)	S
Examine Stop Indication	8308	(2074)	R
Stop Response	8309	(2075)	S
Reset Request	8310	(2076)	S
Examine Reset Indication	8311	(2077)	R
Reset Response	8312	(2078)	S
Resume Request	8313	(2079)	S
Examine Resume Indication	8314	(207A)	R
Resume Response	8315	(207B)	S
InformationReportRequest	8320	(2080)	S
Examine InformationReport Indication Variable	8321	(2081)	R
Read Request	8322	(2082)	S
Write Request	8323	(2083)	S
Transfer InformationReport IndicationData	8330	(208A)	R
Discard InformationReport IndicationData	8339	(2093)	R
Error Request (Generic Negative Response)	8350	(209E)	S
Examine Reject Indication	8351	(209F)	R
Examine Last Error Information	8352	(20A0)	L
Set Local VMD Status	8353	(20A1)	L
Set Local ProgramInvocationState	8355	(20A3)	L
Set Local ProgramInvocationProcessing	8356	(20A4)	L

### Note

Refer to the Index to locate these commands in the manual.

## Association Control Block

The Ethernet Interface uses a group of 5 words, called the Association Control Block (ACB), to provide information to the ladder program about an association. There is one unique ACB for each active association for the Application Interface AP. The PLC memory type and offset for the ACB is established in the local Initiate request or response COMM\_REQ and is thereafter referenced in every COMM\_REQ for that association.

The format of the ACB is specified in the table below.

Table 6-3. Association Control Block

Parameter Description	Word Offset
AssociationStatus Word	0
AssociationStatus Word Extension	1
Invoke ID of confirmed transaction	2
Invoke ID (continued)	3
Problem Code	4

**Association Status Word** - Indicates the current state of this particular association, and any indications or confirmations received, which may require action by the ladder program. See also, Figure 6-2.

**Association Status Word Extension** - Indicates additional information regarding the Association. See also, Figure 6-3.

**Invoke ID** - Indicates the MMS Invocation Identifier of the most recent request which is confirmed by the Positive or Negative Confirm Bit in the Association Status Word.

**Problem Code** - Indicates the reason for a received negative confirmation. If the Problem Code is ff xx, the Ethernet Interface received a Positive Response from the remote device, but had trouble handling the data in the response. Refer to the section titled "MMS Error Encodings" at the end of this chapter for Problem Code values.

### General Association Status Bits

An association is established when either a positive Initiate confirm is received or a positive Initiate response COMM\_REQ is issued. At this point, bit 1 in the Association Status Word ("Association OK" bit) will be set. It should remain ON for the life of the association. When the association is aborted or concluded locally or remotely, the "Association OK" bit will normally be turned OFF and the ACB will no longer be updated.

#### Note

If the local Ethernet Interface is restarted either using the Restart pushbutton or a Station Manager RESTART command, the "Association OK" bit is NOT turned off, although the association is aborted and the ACB will no longer be updated.

## Request Completion

When the Series 90-70 PLC ladder program initiates COMM\_REQs, feedback on the command is given in three ways:

1. The COMM\_REQ OK and FT (fault) outputs indicate whether or not the COMM\_REQ was successfully sent from the Series 90-70 CPU to the Ethernet Interface. These outputs are mutually exclusive.

If the FT output of the COMM\_REQ is set, then the PLC CPU was *not* able to deliver the COMM\_REQ to the Ethernet Interface. The two most common reasons for the FT output to be ON are:

- The Device Independent Area of the COMM\_REQ is incorrectly programmed, or
- The Ethernet Interface's "mailbox" for receiving COMM\_REQs is full.

If the OK output is set, then the COMM\_REQ was successfully delivered to the Ethernet Interface. Once this has occurred, the PLC ladder program may look for the second level of feedback described below.

2. If the COMM\_REQ OK output is set, the status code returned in the COMM\_REQ status word (CRSW) indicates whether the command was in the proper form and was requested in the proper sequence. For example, the CRSW set to hexadecimal 20 (COMM\_REQ Complete With Error) may mean a Write or Read was commanded when no association exists.

If the CRSW is set to 20 hex, the Station Manager Extended Status command (EXS) can be used to determine why the COMM\_REQ was unsuccessful.

Once the CRSW has been set to hexadecimal 40 (COMM\_REQ Complete Without Error), the PLC ladder program may look for the third level of feedback described below.

3. The ACB Positive and Negative Confirm bits indicate that a confirmation message has been received in response to a previous request.

The Problem Code word of the ACB gives further information about why a confirmation was negative. This word is updated when a Negative Confirm is registered in the ACB.

The ACB Confirm bits are set when a confirmation message is received. These bits will be pulsed for each confirmation message received and will remain set and then reset for a minimum of one PLC scan each. When the Confirm bit is set, the Invoke ID of the message being confirmed is also updated in the ACB.

### Note

It is possible that a confirm message will never be received if the remote device does not respond. In this case a "CANCEL Request" may be issued to cancel the outstanding request. This is an allowed exception to the rule regarding duplicate Invoke IDs.

Until either the corresponding response is received or a "CANCEL Request" is issued, it will not be possible to reuse the same Invoke ID nor to CONCLUDE the association.

When multiple confirmation messages are outstanding, the ACB is updated in the order confirmation messages are received. These confirmations are queued so that no message responses are missed. The occurrence of a Confirm should be detected by looking for the low-to-high transition of the Confirm bit. This can be readily accomplished by using the Confirm bit as input to a one-shot in the PLC ladder program.

The ACB Read and Write Indication bits will be turned on and off to reflect successful read and write of local PLC memory by the remote Application Process.

The other ACB Indication bits will be set until some action is taken by the local ladder program or until the message request is cancelled by the remote AP. Usually the action required of the local ladder program is the issuing of a Positive or Negative Response command. The Association Status Word and Association Status Word Extension bits are summarized in the figures below.

### Association Status Word

The Association Status Word (ASW) bits are defined as follows:

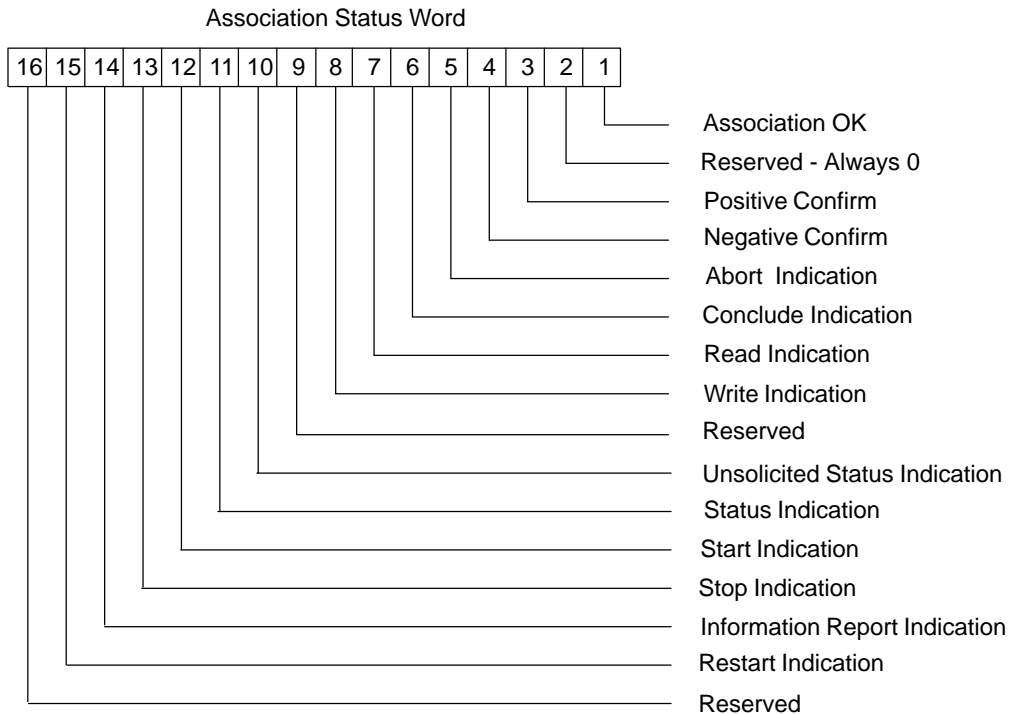

## Association Status Word Extension

The Association Status Word Extension (ASWE) bits are defined as follows:

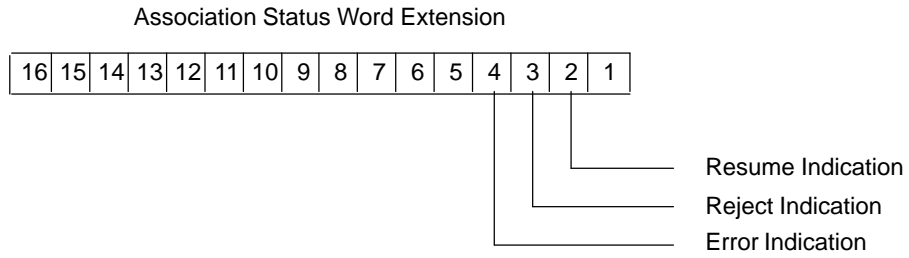

Figure 6-2. Association Status Word Extension Bits

# MMS COMM\_REQ Command Descriptions

## Association Services

The *Association Services* allow the initiation, the orderly conclusion, and the abrupt conclusion of the association between the local and remote applications.

### Initiate Request Command - 8201

The *Initiate Request* command is used to bring up an association with a remote device. The result of this request will be a Positive or Negative Confirm or an Abort Indication. The COMM\_REQ for the Initiate Request command is shown in the table below.

Table 6-4. Initiate Request COMM\_REQ

Parameter Description	Word Offset	Value
Word Length of MDB	0	73
Wait/NoWait Flag	1	0 (No Wait)
CRSW, Memory Type <sup>1</sup>	2	See Footnote 1
CRSW, Offset	3	0 - Max Configured
Idle Timeout Value	4	0
MaximumCommunicationTime	5	0
<b>CommandNumber</b>	6	8201(2009H)
AssociationControlBlockPointer, Memory Type <sup>1</sup>	7	See Footnote 1
AssociationControlBlockPointer, Offset	8	
AssociationContext	9	0 or 10
MaximumMessageSize	10	0 or 64 and up
MaximumServicesOutstanding, Calling	11	0 - 6
MaximumServicesOutstanding, Called	12	0 - 6
Length of Remote Application Common Name	13	
RemoteApplicationCommonName (This entry uses 32 words of memory)	14 - 45	characterstring
Length of Application Context Name	46	0 or 1 - 64
ApplicationContextName (This entry uses 32 words of memory)	47 - 78	characterstring (2characters/word)

<sup>1</sup> Quick Reference:   Memory Type   %R   %AI   %AQ    %I   %Q    %T   %M  
                           Decimal Value   8    10    12   70   72   76   76

**Command Number** - Identifies this as an Initiate Request command.

**Association Control Block** - The PLC address allocated for the ACB for this association. After the association is established, the specific association is in subsequent ladder commands by this ACB location. Any command for this association must specify this ACB location in its MDB.



**Association Context** - Determines which of the 7-layer contexts will be used for the association. For most applications a value of 0 is used. The parameter may have one of the following values on the Ethernet Interface:

- 0 - MMS (IS 9506) services over 7-layer.
- 10 - MMS (DIS 9506) services over 7-layer.

**Maximum Message Size** - The MMS maximum message size to be used on this association. If non-zero, it must be no less than 64 and no more than *mmaxmsgsz*. If this parameter is 0, the default maximum message size is suggested. The default size corresponds to the *mmaxmsgsz* configuration parameter.

**Maximum Services Outstanding, Calling** - The number of messages which can be simultaneously outstanding on the association. If this is set to 0, the value of 6 is used. If set to 6 or greater, the value 6 is used.

**Maximum Services Outstanding, Called** - The number of messages which can be simultaneously outstanding from the remote peer application. Specifying the value of 0 prevents the remote peer from being able to initiate communication. If set to 6 or greater, the value 6 is used.

**Length of Remote Application Common Name** - The number of characters in the Application Common Name. This name may be up to 64 characters for 7-layer communications.

**Remote Application Common Name** - A character string indicating the remote Application Common Name. This is the name of the application process with which the Series 90-70 application process wishes to communicate.

**Length of Application Context Name** - The number of characters in the Application Context Name. Putting a 0 in this field will cause the default Application Context Name from the configuration parameters to be used.

**Application Context Name**- (Only required if length is not 0). A character string indicating the remote Application Context Name. If the Length field is not 0, this field must be set to:

“ISO MMS” - 7-layer (ACSE/Presentation) context

## Initiate Indication Service

The *Initiate Indication Service* is used to indicate that a remote application wishes to establish an association with the Application Interface. The PLC ladder program is notified of an Initiate Indication by the Initiate Indication Pending bit in the LAN Interface Status Word (bit 15). The ladder program may issue an Examine Initiate Indication command prior to issuing the Initiate Response command, but this is not required.

## Examine Initiate Indication Command - 8202

The *Examine Initiate Indication* command may be used to examine the request for an association made by a remote application. Upon examining the Initiate Indication, the local Application Process should normally follow with an Initiate Response command. The COMM\_REQ format for the Examine Initiate Indication command is shown in the table below.

**Table 6-5. Examine Initiate Indication COMM\_REQ**

Parameter Description	Word Offset	Value
Word Length of MDB	0	3
Wait/NoWait Flag	1	0 (No Wait)
CRSW, Memory Type <sup>1</sup>	2	Footnote 1
CRSW, Offset	3	0 - Max Configured
Idle Timeout Value	4	0
MaximumCommunicationTime	5	0
<b>CommandNumber</b>	6	8202(200AH)
Examine Data Buffer, Memory Type <sup>1</sup>	7	See Table 6-16
Examine Data Buffer, Offset	8	1 - Max Configured

<sup>1</sup> Quick Reference:   Memory Type   %R   %AI   %AQ    %I   %Q    %T   %M  
                           Decimal Value   8    10    12    70   72    74    76

**Command Number** - Identifies this as an Examine Initiate Indication command.

**Examine Data Buffer** - The Series 90-70 address where the data to be examined is to be put.

The result of this command is that 140 octets of data will be placed at the address specified in the MDB. The format of this data is shown in the table below.

**Table 6-6. Examine Initiate Indication Data**

Parameter Description	Word Offset	Value
AssociationContext	0	0 - 2
MaximumMessageSize	1	64 and up
MaximumServicesOutstanding, Calling	2	0 - 6
MaximumServicesOutstanding, Called	3	0 - 6
Length of Remote Application Common Name	4	0 - 64
RemoteApplicationCommonName	5 - 36	characterstring
Length of Application Context Name	37	1 - 64
ApplicationContextName	38 - 69	characterstring

**Association Context** - The association context that is to be used for this association. The parameter may have one of the following values on the Ethernet Interface:

- 0 - MMS (IS 9506) services over 7-layer ACSE/Presentation.
- 10 - MMS (DIS 9506) services over 7-layer ACSE/Presentation.

**Maximum Message Size** - The suggested maximum message size from the remote peer application.

**Maximum Services Outstanding, Calling** - The suggested maximum number of outstanding services on the association to be initiated from the remote peer application.

**Maximum Services Outstanding, Called** - The suggested maximum number of outstanding services on the association to be permitted to the Series 90-70 PLC application.

**Length of Remote Application Common Name** - The octet length of the remote Application Common Name. This name may be up to 64 characters for the 7-layer (ACSE/Presentation) context.

**Remote Application Common Name** - A character string indicating the Application Common Name of the remote peer application attempting to initiate this association. Any unused characters (max string length is 64) will be zero filled.

**Length of Application Context Name** - The number of characters in the Application Context Name.

**Application Context Name** - A character string indicating the Application Context Name.

## Initiate Response Command - 8203

The *Initiate Response* command is used to respond to the reception of an Initiate Indication which has been indicated by the Initiate Indication Pending bit (bit 15) of the LAN Interface Status Word being 1. This response determines whether an association with a requesting remote application will be established or not. The association will be established by Sending a Positive Initiate Response. The ACB to be used for this particular association is defined in this COMM\_REQ. The COMM\_REQ format for the Initiate Response command is shown in the table below.

**Table 6-7. Initiate Response COMM\_REQ**

Parameter Description	Word Offset	Value
Word Length of MDB	0	8
Wait/NoWait Flag	1	0 (No Wait)
CRSW, Memory Type <sup>1</sup>	2	Footnote 1
CRSW, Offset	3	0 - Max Configured
Idle Timeout Value	4	0
MaximumCommunicationTime	5	0
<b>CommandNumber</b>	6	8203(200BH)
AssociationControlBlockPointer, Memory Type <sup>1</sup>	7	Footnote 1
AssociationControlBlockPointer, Offset	8	
Positive or Negative Response	9	0, 1
Problem Code	10	See Table 6-60
MaximumMessageSize	11	0, 64 - Max Configured
MaximumServicesOutstanding, Calling	12	0 - 6
MaximumServicesOutstanding, Called	13	0 - 6

<sup>1</sup> Quick Reference:    Memory Type    %R    %AI    %AQ    %I    %Q    %T    %M  
                                   Decimal Value    8    10    12    70    72    74    76

**Command Number** - Identifies this as an Initiate Response command.

**Association Control Block** - The PLC address of the Association Control Block for this association. This field is ignored for Negative Responses.

**Positive or Negative Response** - Indicates whether the request for an association was accepted. If this parameter is 0, then the request is accepted and a Positive Response is sent to the requesting application. If this parameter is 1, then the request is rejected and a Negative Response is sent to the requesting application.

**Problem Code** - Indicates the nature of the problem if the Positive or Negative Response parameter is 1 (request was unsuccessful). This field is ignored if a Positive Response is being sent.

**Maximum Message Size** - Specifies the final negotiated value of the maximum message size for the association. In NO CASE should the negotiated value be larger than the suggested value received in the Examine Initiate Indication MDB, nor should the value be larger than the Maximum MMS Message Size configured for this station. If 0 is used, the suggested Maximum Message Size will be accepted.

**Maximum Services Outstanding, Calling** - Specifies the final negotiated value of the maximum services outstanding for the remote node. If the negotiated value is larger than the suggested value received in the Examine Initiate Indication MDB, or if zero is used, the suggested value will be accepted.

**Maximum Services Outstanding, Called** - Specifies the final negotiated value of the maximum services outstanding for the local node. If the negotiated value is larger than the suggested value received in the Examine Initiate Indication MDB, or if zero is used, the suggested value will be accepted.

## Initiate Confirmation Service

The *Initiate Confirm Service* uses the Positive and Negative Confirm bits in the Association Status Word of the ACB. The bits indicate whether the responding application accepted the Initiate Request.

When the Negative Confirm bit is set, the Problem Code in the ACB is updated with the reason for the negative confirm.

If the Positive Confirm bit is set, the association will be established and the Association OK bit in the ACB will be 1. Information about the Positive Initiate Confirm may be examined using the Examine Positive Initiate Confirm command.

## Examine Positive Initiate Confirm Command - 8204

The COMM\_REQ format of the *Examine Positive Initiate Confirm* command is shown in Table 6-9. The command number for this command is 8204 (200CH). The result of this command is that 6 octets of data will be placed at the Data Buffer specified in the MDB. The format of this data is shown in the table below.

**Table 6-8. Examine Positive Initiate Confirm Data**

Parameter Description	Word Offset	Value
MaximumMessage Size	0	64 and up
MaximumServicesOutstanding, Calling	1	0 - 6
MaximumServicesOutstanding, Called	2	0 - 6

**Maximum Message Size** - The final negotiated maximum message size for this association.

**Maximum Services Outstanding, Calling** - The final negotiated maximum number of services allowed to be outstanding from the local Series 90-70 PLC application on this association.

**Maximum Services Outstanding, Called** - The final negotiated maximum number of services allowed to be outstanding from the remote peer application on this association.

All Examine commands (except for the Examine Initiate Indication and the Examine Unsolicited Status commands) have the same format. This format is shown in the table below.

**Table 6-9. Generic Examine COMM\_REQ**

Parameter Description	Word Offset	Value
Word Length of MDB	0	5
Wait/NoWait Flag	1	0 (No Wait)
CRSW, Memory Type <sup>1</sup>	2	See Footnote 1
CRSW, Offset	3	0 - Max Configured
Idle Timeout Value	4	0
MaximumCommunicationTime	5	0
<b>CommandNumber</b>	6	82xx
AssociationControlBlockPointer, Memory Type <sup>1</sup>	7	See Footnote 1
AssociationControlBlockPointer, Offset	8	
Examine Data Buffer, Memory Type	9	See Footnote 1
Examine Data Buffer, Offset	10	

<sup>1</sup> Quick Reference:   Memory Type   %R   %AI   %AQ   %I   %Q   %T   %M  
                           Decimal Value   8   10   12   70   72   74   76

**Command Number** - Identifies this as a Conclude Request command.

**Association Control Block** - The PLC address of the Association Control Block for this association.

**Examine Data Buffer** - The PLC address of the Association Control Block for this association.

## Conclude Request Command - 8205

This *Conclude Request* command can be used to request the orderly termination of an MMS Application Association.

### Note

The *Conclude Request* will not be allowed if there is an outstanding Status Indication (ASW bit #11), Start Indication (ASW bit #12), Stop Indication (ASW bit #13), Reset Indication (ASW bit #15), or Resume Indication (ASWE bit #2). The PLC ladder program must respond to these indications before a *Conclude Request* can be allowed.

The COMM\_REQ for the Conclude Request command is shown in the table below.

Table 6-10. Conclude Request COMM\_REQ

Parameter Description	Word Offset	Value
Word Length of MDB	0	3
Wait/NoWait Flag	1	0 (No Wait)
CRSW, Memory Type <sup>1</sup>	2	See Footnote 1
CRSW, Offset	3	0 - Max Configured
Idle Timeout Value	4	0
Maximum Communication Time	5	0
<b>Command Number</b>	6	8205 (200DH)
Association Control Block Pointer, Memory Type	7	See Footnote 1
Association Control Block Pointer, Offset	8	

<sup>1</sup> Quick Reference: Memory Type    %R   %AI   %AQ    %I   %Q   %T   %M  
 Decimal Value    8   10   12   70   72   74   76

**Command Number** - Identifies this as a Conclude Request command.

**Association Control Block** - The PLC address of the Association Control Block for this association.

## Conclude Indication Service

The *Conclude Indication Service* indicates that the remote application wishes to terminate the association. This indication is detected by bit 6 of the ACB Association Status Word. The PLC Application should respond to this indication with the Conclude Response command.





## Abort Request Command - 8207

The *Abort Request* command is used to abruptly conclude the association. This results in the immediate termination of the ACSE Association using the ACSE A-Abort service.

The COMM\_REQ format for the Abort Request command is shown in the table below.

**Table 6-12. Abort Request COMM\_REQ**

Parameter Description	Word Offset	Value
Word Length of MDB	0	3
Wait/NoWaitFlag	1	0 (No Wait)
CRSW, Memory Type <sup>1</sup>	2	See Footnote 1
CRSW, Offset	3	0 - Max Configured
Idle Timeout Value	4	0
MaximumCommunicationTime	5	0
<b>CommandNumber</b>	6	8207(200FH)
AssociationControlBlockPointer, Memory Type <sup>1</sup>	7	See Footnote 1
AssociationControlBlockPointer, Offset	8	

<sup>1</sup> Quick Reference:   Memory Type   %R   %AI   %AQ    %I   %Q    %T   %M  
                           Decimal Value   8    10    12   70   72   74   76

**Command Number** - Identifies this as an Abort Request command.

**Association Control Block** - The PLC address of the Association Control Block for this association.

## Abort Indication Service

The *Abort Indication Service* is used to indicate that the remote application abruptly terminated the association.

This indication is shown in bit 5 of the ACB Association Status Word. When the Abort Indication bit is set to 1, bit 0 (Association OK) will be reset to 0.

## Examine Association Options Command - 8300

The Series 90-70 PLC application can use an *Examine Association Options* command to retrieve the MMS negotiable parameters in effect for the association.

The format of the Examine Association Options COMM\_REQ is shown in Table 6-9. The command number for this command is 8300 (206CH). The result of this command is that 26 octets of data will be placed at the address specified in the MDB.

The format of this data is shown in the table below.

**Table 6-13. Examine Association Options Data**

Parameter Description	Word Offset	Value
MaximumMessage Size	0	64 and up
MaximumServices Outstanding, Local	1	0 - 6
MaximumServices Outstanding, Remote	2	0 - 6
Data Structure Nesting Level	3	0, 1
Protocol Version	4	0, 1
Parameter Conformance Building Blocks	5	bitstring
Remote Services Supported Bit String	6 - 12	bitstring

**Maximum Message Size** - The maximum message size.

**Maximum Services Outstanding, Local** - The Maximum Services Outstanding for the local ladder program.

**Maximum Services Outstanding, Remote** - The Maximum Services Outstanding for the remote application.

**Data Structure Nesting Level** - The Data Structure Nesting Level parameter will return the value 1 if array support has been negotiated or zero otherwise.

**Protocol Version** - The Protocol Version parameter is an identifying number of the protocol version. Version number 0 identifies ISO DIS 9506. Version number 1 identifies ISO IS 9506.

**Parameter Conformance Building Blocks** - The bits of the Parameter Conformance Building Block parameter are described in the table below. A value of 1 for the bit indicates that the corresponding parameter is supported.

**Table 6-14. Parameter Conformance Building Blocks**

Parameter Option	Bit
Arrays	8
Structures	7
Named Access	6
Address Access	5
Scattered Access	4
Third Party	3

**Remote Services Supported Bit String** - The bits in the Remote Services Supported Bit String parameter describe the MMS services available in the remote peer as shown in the table below. A value of 1 for the bit indicates that the corresponding service is supported.

**Table 6-15. Remote Peer Services Supported**

<b>Service</b>	<b>Word Offset</b>	<b>Bit No</b>
Status	6	8
Get Name List	6	7
Identify	6	6
Rename	6	5
Read	6	4
Write	6	3
Get VariableAccessAttributes	6	2
Define Named Variable	6	1
Define Scattered Access	6	16
Get Scattered Access Attributes	6	15
Delete VariableAccess	6	14
Define Named VariableList	6	13
Get Named VariableAttributes	6	12
Delete Named VariableList	6	11
Define Named Type	6	10
Get Named Type Attributes	6	9
Delete Named Type	7	8
Input	7	7
Output	7	6
Take Control	7	5
RelinquishControl	7	4
Define Semaphore	7	3
Delete Semaphore	7	2
Report Semaphore Status	7	1
Report Pool Semaphore Status	7	16
Report Semaphore Entry Status	7	15
Initiate Download Sequence	7	14
Download Segment	7	13
Terminate Download Sequence	7	12
Initiate Upload Sequence	7	11
Upload Segment	7	10
Terminate Upload Sequence	7	9
Request Domain Download	8	8
Request Domain Upload	8	7
Load Domain Content	8	6
Store Domain Content	8	5
Delete Domain	8	4
Get Domain Attributes	8	3
Create ProgramInvocation	8	2
Delete ProgramInvocation	8	1
Start	8	16
Stop	8	15
Resume	8	14

**Table 6-15. Remote Peer Services Supported - Continued**

Service	Word Offset	Bit No
Reset	8	13
Kill	8	12
Get ProgramInvocationAttributes	8	11
Obtain File	8	10
Define Event Condition	8	9
Delete Event Condition	9	8
Get Event Condition Attributes	9	7
Report Event Condition Status	9	6
Alter Event Condition Monitoring	9	5
TriggerEvent	9	4
Define Event Action	9	3
Delete Event Action	9	2
Get Event Action Attributes	9	1
Report Event Action Status	9	16
Define Event Enrollment	9	15
Delete Event Enrollment	9	14
Alter Event Enrollment	9	13
Report Event Enrollment Status	9	12
Get Event Enrollment Attributes	9	11
AcknowledgeEventNotification	9	10
GetAlarmSummary	9	9
GetAlarmEnrollmentSummary	10	8
Read Journal	10	7
Write Journal	10	6
InitializeJournal	10	5
ReportJournalStatus	10	4
CreateJournal	10	3
Delete Journal	10	2
GetCapabilityList	10	1
File Open	10	16
File Read	10	15
File Close	10	14
File Rename	10	13
File Delete	10	12
File Directory	10	11
UnsolicitedStatus	10	10
InformationReport	10	9
EventNotification	11	8
Attach to Event Condition	11	7
Attach to Semaphore	11	6
Conclude	11	5
Cancel	11	4

# Memory Access Services

## Overview

Variables may be *named* or *unnamed*, *scalar* or *array*.

### Named Variables

A *Named variable* is identified by a unique symbolic name that references the variable object. The Series 90-70 PLC Ethernet Interface supports a Variable Name table with 0 to 64 Variable Names defined in the VMD-specific scope, each of which may be accessed by a remote application. Domain Specific variables may also be defined.

Named variables are defined for a station through the GSM Configuration Editor and downloaded to the station.

A variable name may identify either a *scalar* (only a single element in the variable) or an *array* variable (which has one or more elements). Variable Names are used to simplify host application and ladder programs and make them portable. A Variable Name can consist of up to 32 characters. These characters may be any of the following: "A-Z", "a-z", "0-9", "\$", and "\_". Variable names are *case sensitive* and "TEMP1" and "temp1" will *not* be treated as the same variable name. The first character of the variable name must be alphabetic.

The Series 90-70 Ethernet Interface allows up to 64 Named Variables to be defined for the VMD Specific scope. These variables are known to (i.e., accessible to) all associations in the Series 90-70 VMD.

The Series 90-70 PLC Ethernet Interface software does not support domain-or Application Association-specific variables.

### Unnamed Variables

*Unnamed variables* can be identified in any of three ways: *numeric addresses*, *symbolic addresses*, and *unconstrained addresses*. For all three forms of identifying unnamed variables, the way addresses are mapped onto objects (for example, register and I/O tables) in the device is device dependent, i.e., defined uniquely for the Series 90-70 PLC.

Unnamed variables are *not* configured on the GSM. Instead, the Series 90-70 PLC provides a default variable definition based on the target memory address. This default definition is described below for each unnamed variable type. This definition can be used or superceded by individual MMS requests that access these variables. Unnamed variables may be scalar or array.

### Numeric Addresses

A *Numeric Address* contains an absolute address of data as it maps into the Series 90-70 PLC memory. This numeric address must consist of an unsigned 32-bit integer which specifies the address information when sent to the Ethernet Interface. Unless specified otherwise in the MMS request, data from the Register Table and Analog I/O tables are returned as unsigned 16-bit integer scalar, from all other tables as Boolean scalar.

The Series 90-70 Ethernet Interface interprets the unsigned integer as two word values. The least significant word of the integer is the code that identifies which memory type is being accessed. This is referred to as the *memory type*. The most significant word of the numeric address is the *unit offset* into that table. For example, %R4 should be encoded as 00030008 (hexadecimal). The table below gives the memory type codes available through the Ethernet Interface.

Table 6-16. Series 90-70 PLC Memory Organization

Decimal Code	Hexadecimal Code	Memory Type	Unit Size
8	08	Register Table (%R)	word
10	0A	Analog Input Table (%AI)	word
12	0C	Analog Output Table (%AQ)	word
16	10	Discrete Input Table (%I)	byte
18	12	Discrete Output Table (%Q)	byte
20	14	Discrete Temporary (%T)	byte
22	16	Discrete Internal (%M)	byte
24	18	Special Contacts A (%SA)	byte
26	1A	Special Contacts B (%SB)	byte
28	1C	Special Contacts C (%SC)	byte
30	1E	System Fault (%S), Read only	byte
56	38	Genius Seamless (%G), % GA, etc. <sup>1</sup>	byte
58	3A	Boolean BCD Temporary	byte
60	3C	Report Fault	bit
70	46	Discrete Input Table (%I)	bit
72	48	Discrete Output Table (%Q)	bit
74	4A	Discrete Temporary (%T)	bit
76	4C	Discrete Internal (%M)	bit
78	4E	Special Contacts A (%SA)	bit
80	50	Special Contacts B (%SB)	bit
82	52	Special Contacts C (%SC)	bit
84	54	System Fault (%S), Read only	bit
86	56	Genius Seamless (%G), % GA, etc. <sup>1</sup>	bit
114	72	Discrete Input Override	byte
116	74	Discrete Output Override	byte
118	76	Discrete Temporary Override	byte
120	78	Discrete Internal Override	byte
132	84	Discrete Input Transition	byte
134	86	Discrete Output Transition	byte
136	88	Discrete Temporary Transition	byte
138	8A	Discrete Internal Transition	byte
150	96	Discrete Input Override	bit
152	98	Discrete Output Override	bit
154	9A	Discrete Temporary Override	bit
156	9C	Discrete Internal Override	bit
186	BA	Discrete Direct	byte
188	BC	Report Fault	byte

<sup>1</sup> Refer to GEK-90486-1, Genius I/O System User's Manual.

### Note

The address ranges for these tables vary according to CPU model and user configuration.

All offsets are zero based.

## Symbolic Addresses

A *Symbolic Address* is a character string which symbolically represents a memory location, "R24" for example. Memory in the Series 90-70 PLC may be accessed by the use of Symbolic Addresses.

The Symbolic Addresses defined for the Series 90-70 PLC are shown in the table below. When referencing a symbolic address, leading zeros are optional. Unless specified otherwise in the MMS request, data from the Register Table and Analog I/O tables are returned as unsigned 16-bit integer scalar, from all other tables as Boolean scalar.

**Table 6-17. Series 90-70 PLC Symbolic Addresses**

Series 90-70 PLC Symbolic Address	Description	Data Type/Size
R00001 - R65535	Registers	Unsigned Integer, 16 bits
AI00001 - AI65535	Analog Input	Unsigned Integer, 16 bits
AQ00001 - AQ65535	Analog Output	Unsigned Integer, 16 bits
I00001 - I65535	Discrete Input	Boolean, 1 bit
Q00001 - Q65535	Discrete Output	Boolean, 1 bit
O00001 - O65535	Discrete Output (Alternate form)	Boolean, 1 bit
T00001 - T65535	Discrete Temporary	Boolean, 1 bit
M00001 - M65535	Discrete Internal	Boolean, 1 bit
G00001 - G65535	Genius Seamless	Boolean, 1 bit
SA00001 - SA65535	Special Contacts A	Boolean, 1 bit
SB00001 - SB65535	Special Contacts B	Boolean, 1 bit
SC00001 - SC65535	Special Contacts C	Boolean, 1 bit
S00001 - S65535	System Fault, Read only	Boolean, 1 bit

## Unconstrained Addresses

*Unconstrained Addresses* have no MMS-defined structure beyond being a sequence of octets which must be interpreted by the receiving device.

The Series 90-70 Ethernet Interface reserves this unnamed variable access type for future use. Any attempt to access Series 90-70 memory through the Ethernet Interface with Unconstrained Address will (for now) result in a Negative Response with an error class (see Table 6-60) of 7 (access) and an error code of 1 (object-access-unsupported).

The Series 90-70 ladder programs may issue communication requests (e.g., Read Requests) using an Unconstrained Address. It will be up to the remote device to interpret the specified address.

## Scalar Variables

A *Scalar Variable* contains 1 element only. An element may be as simple as a single bit, it may consist of a 32-bit integer stored in 2 adjacent registers, or it may be a string of octets spanning several dozen words. Regardless of its size, a scalar variable must be accessed as a whole, it cannot be subdivided or split. The Number of Elements parameter in a COMM\_REQ that accesses a scalar variable must be 1.

## Array Variables

An *Array Variable* refers to a collection of related elements. For array variables, the variable definition describes which PLC memory locations are to be treated as an array.

Both Named and Unnamed variables may be referenced as array variables. For example, array variable “TempInputs” may be defined as input points 100 through 200 and represent a group of temperature inputs for a particular application. For unnamed array variables, the referenced PLC memory table is treated as an array. So if %R1, the start of the register table, is specified as an unnamed array variable, the variable access will treat the register table (for the number of elements/registers specified) as an array.

If only a portion of the array is to be accessed, the appropriate alternate access variable type should be specified. The Alternate Access Index parameter in the COMM\_REQ describes the first element of the array to be accessed. The Number of Elements parameter describes the number of array elements to be accessed. For example, supplying “R01” as the VariableName/Address parameter in a COMM\_REQ with the Variable Type parameter equal to 10 (see Table 6-20), the Alternate Access Index parameter equal to 4, and the Number of Elements parameter equal to 7, would refer to registers 5 through 11. (Register 5 is the first register returned, since indexing in MMS begins at the value 0.)



## Read Request Command - 8322

The *Read Request* command is used to send an MMS Read message. This service supports all three scopes of the MMS read service. The COMM\_REQ format of the Read Request is shown in the table below.

**Table 6-18. Read Request COMM\_REQ**

Parameter Description	Word Offset	Value
Word Length of MDB	0	49
Wait/NoWait Flag	1	0 (No Wait)
CRSW, Memory Type <sup>1</sup>	2	See Footnote 1
CRSW, Offset	3	0 - Max Configured
Idle Timeout Value	4	0
Maximum Communication Time	5	0
<b>Command Number</b>	<b>6</b>	<b>8322 (2082H)</b>
Association Control Block Pointer; Memory Type <sup>1</sup>	7	See Footnote 1
Association Control Block Pointer; Offset	8	
Invoke ID	9 - 10	0 - 65,535
Data Type	11	See Table 6-19
Data Type Size	12	See Table 6-19
Variable Type	13	See Table 6-20
Length of Variable Name or Address	14	1 - 32 or 1 - 16
Variable Name or Address	15 - 30	
Alternate Access Index (only used if Variable Type 8-11)	31 - 32	0 or more
Number of Elements	33	See Table 6-20
Variable Scope	34	See Table 6-54
Length of Read Data Buffer	35	1 to 2048
Read Data Buffer; Memory Type <sup>1</sup>	36	See Table 6-16
Read Data Buffer; Offset <sup>1</sup>	37	See Table 6-16
Length of Domain Name	38	0 - 32
Domain Name	39 - 54	characterstring

<sup>1</sup> Quick Reference: Memory Type %R %AI %AQ %I %Q %T %M  
 Decimal Value 8 10 12 70 72 74 76

**Command Number** - Identifies this as a Read Request command.

**Association Control Block** - The PLC address of the Association Control Block for this association.

**Invoke ID** - The unique MMS Invocation ID.

**Data Type** - Specifies the expected type of the returned data for the read. If the data on the read response does not match this type, an error will be generated. Valid Data Type values are given in the table below.

**Table 6-19. Data Type Values**

Data Type	Data Type Code	Data Type Size(s)
Boolean	3	1 bit
BitString	4	1 to 2048 bits
Integer	5	1 to 32 bits
Unsigned	6	1 to 32 bits
FloatingPoint	7	4 octets
Octet String	9	1 to 2048 octets
VisibleString	10	1 to 2048 octets

**Note**

Data Type Size of integer and unsigned values is specified in bits. Data Type and Data Type Size for Unnamed Variables are pre-defined based on PLC memory location.

**Data Type Size** - Defines the number of octets or bits in the data type. The Data Type Size parameter should use the units and ranges shown in the table above.

**Variable Type** - Specifies the kind of variable access (i.e., Named or Unnamed) and the options that will be used for the access. The table below gives the valid values for the Variable Type parameter and their meaning.

**Table 6-20. Variable Type Values**

Value	Variable Type	No. Elements
0	NamedScalar Variable	1
1	UnnamedScalar Variable - Numeric Address	1
2	UnnamedScalar Variable - Symbolic Address	1
3	UnnamedScalar Variable - Unconstrained Address	1
4	NamedArray Variable	Array Size
5	UnnamedArray Variable - Numeric Address	Array Size
6	UnnamedArray Variable - Symbolic Address	Array Size
7	UnnamedArray Variable - Unconstrained Address	Array Size
8	NamedArray VariableAlternate Access	ElementsDesired
9	UnnamedArray Variable - Numeric AddressAlternate Access	ElementsDesired
10	UnnamedArray Variable - Symbolic AddressAlternate Access	ElementsDesired
11	UnnamedArray Variable - Unconstrained AddressAlternate Access	ElementsDesired

**Length of Variable Name or Address** - When the Variable Type parameter is set to the value 0, 4, or 8, a variable name is used. The Length of Variable Name parameter is the length of Variable Name in characters.

An example of a variable name would be the variable name "REGISTER" with the Length of Variable Name parameter equal to 8, which might be used to access a Series 90-70 PLCs Register table. Refer to the discussion "Named Variables" earlier in this chapter for more information.

When the Variable Type parameter is set to a value other than 0, 4, or 8, an address is used. The Address parameter contains the Numeric Address or Symbolic Address. The Address parameter may be up to 16 octets in length.

An example of a Symbolic Address would be the address "R12" which would be used to access Series 90-70 PLC Register 12. Table 6-17 specifies the valid Symbolic Addresses for the Series 90-70 PLC.

An example of a Numeric Address would be address 0000 0008H which would be used to access Register 1 in the Series 90-70 PLC.

The Length of Address parameter is the length of the address in octets (or characters for the Symbolic Address). For Numeric Addresses, the length should be 4 octets.

**Variable Name or Address** - The name or address of the specific variable to be read. It consists of either a character string (which is less than or equal to 32 characters in length) or an address.

**Alternate Access Index** - Specifies the beginning index of an alternate access for variable types 8 through 11.

**Number of Elements** - Specifies the number of items which will be read. If the number of values in the read response does not match the Number of Elements parameter, an error will be generated.

**Variable Scope** - Specifies the scope of the variable to be read from the remote station. If the scope parameter specifies Domain Specific Scope, the Domain Name parameter should specify the domain in which the desired variable access is defined.

**Length of Read Data Buffer** - The Read Data Buffer parameter specifies where the returned data (from the read) are to be stored. If this buffer is not large enough to permit storing the requested amount of information, the request receives a COMM\_REQ Complete with Error. The buffer length is expressed in units appropriate to the Read Data Buffer's memory type.

**Read Data Buffer** - Specifies the location where the returned read data is to be stored.

**Length of Domain Name** - Unless the Variable Type parameter is specified as 0, 4, or 8 and the Variable Scope is specified as 1, this parameter is ignored. The Length of Domain Name parameter specifies the number of characters in the name of the domain in whose scope the variable to be read is defined.

**Domain Name** - Used to specify the name of the domain in the remote application associated with a named variable in a Domain Specific scope.

## Read Indication Service

The *Read Indication Service* uses the Read Indication bit (bit 7) of the Association Status Word to indicate that the remote application requested to read local PLC memory. The Ethernet Interface reads the data and responds to this request. The Read Indication is for information only; no action need be taken by the local ladder program. No Read Response service is available to the local ladder program.

## Read Confirm Service

The *Read Confirm Service* uses the Positive and Negative Confirm bits in the Association Status Word of the ACB. This service determines whether the read from the remote application was successful.

When the Negative Confirm bit is set, the Problem Code in the ACB is updated with the reason for the negative confirm. The ladder program may (but need not) use the Examine Last Error Information command to learn more about the complaint. If the Positive Confirm bit is set, the read data will have been placed in the Read Data Buffer locations.

## Write Request Command - 8323

The Series 90-70 PLC application can use the *Write Request* command to generate an MMS Write request. This service supports all three scopes of the MMS write service. The COMM\_REQ format of the Write Request is shown in the table below.

Table 6-21. Write Request COMM\_REQ

Parameter Description	Word Offset	Value
Word Length of MDB	0	128
Wait/NoWait Flag	1	0 (No Wait)
CRSW, Memory Type <sup>1</sup>	2	See Footnote 1
CRSW, Offset	3	0 - Max Configured
Idle Timeout Value	4	0
Maximum Communication Time	5	0
<b>Command Number</b>	6	8323(2083H)
Association Control Block Pointer, Memory Type <sup>1</sup>	7	See Footnote 1
Association Control Block Pointer, Offset	8	
Invoke ID	9 - 10	0 - 65,535
Data Type	11	See Table 6-19
Data Type Size	12	See Table 6-19
Variable Type	13	See Table 6-20
Length of Variable Name or Address	14	1 - 16 or 1 - 32
Variable Name or Address	15 - 30	
Alternate Access Index	31 - 32	0 or more
Number of Elements	33	See Table 6-20
Variable Scope	34	See Table 6-54
Length of Write Data	35	1 to 2048
Length of Domain Name	36	0 - 32
Domain Name	37 - 52	characterstring
Write Data or Buffer Address	53 - 133	

<sup>1</sup> Quick Reference:    Memory Type    %R    %AI    %AQ    %I    %Q    %T    %M  
                                   Decimal Value    8    10    12    70    72    74    76

**Command Number** - Identifies this as a Write Request command.

**Association Control Block** - The PLC address of the Association Control Block for this association.

**Invoke ID** - The unique MMS Invocation ID.

**Data Type** - Specifies the type of data to be written to the remote variable.

**Data Type Size** - Specifies the size of the data elements to be written to the remote variable.

**Variable Type** - Chooses the kind of variable access (i.e., Named or Unnamed) and the options which will be used for the access.

**Length of Variable Name or Address** - When the Variable Type parameter specifies one of the Named Variable types, the Variable Name or Address parameter specifies the name value for the remote variable to be written. When the Variable Type parameter specifies one of the Unnamed (address) Access types, the Variable Name or Address parameter specifies the address value for the unnamed access. Numeric Addresses are

always integer values. Symbolic Addresses require intimate knowledge of the remote application in order to be interpreted correctly.

The Length of Variable Name or Address parameter specifies the number of octets in the name or address specification which determine where in the remote application the data to be written is located.

- For Named Variable access, this is the number of characters (1 to 32) in the name of the variable in the remote node.
- For Numeric Addresses, this value should be 4.
- For Symbolic Addresses, this value is the number of octets (1 to 16) in the Address value.

**Variable Name or Address** - The name or address of the specific variable to be written.

**Alternate Access Index** - Alternate Access allows portions of arrays to be written. The Alternate Access Index is used to specify the beginning index of an alternate access for variable types 8 through 11.

**Number of Elements** - Specifies the number of items to be written.

**Variable Scope** - Specifies the proper scope for the variable access. If the Variable Scope parameter specifies Domain Specific Scope, the Domain Name parameter should specify the domain in which the desired variable access is defined.

**Length of Write Data** - The buffer length expressed in units appropriate to the Write Data memory type.

**Length of Domain Name** - Unless the Variable Type parameter specifies a named variable (has value 0, 4 or 8) and the Variable Scope parameter specifies Domain Specific (has the value 1), this parameter is ignored. The Length of Domain Name parameter specifies the number of characters in the name of the domain in the remote application in whose scope the variable to be written is defined.

**Domain Name** - Used to specify the Name of the domain in the remote application associated with a named variable in a Domain Specific scope.

**Write Data or Buffer Address** - When the amount of data to be sent is 162 octets or less, this parameter contains the actual data to be transferred.

When the amount of data to be sent exceeds 162 octets, word offset 53 contains a memory type (see Table 6-16) and word offset 54 contains the PLC memory offset of where the actual data exists.

## Write Indication Service

The *Write Indication Service* uses the Write Indication bit (bit 8) of the Association Status Word to indicate that the remote application requested to write local PLC memory. The Ethernet Interface writes the data and responds to this request. The Write Indication is for information only; no action need be taken by the local ladder program. No Write Response service is available to the local ladder program.

---

## Write Confirm Service

The *Write Confirm Service* is provided by the Positive and Negative Confirm bits in the Association Status Word of the ACB. This service determines whether the write to the remote application was successful.

When the Negative Confirm bit is set, the Problem Code in the ACB is updated with the reason for the negative confirm. The ladder program may (but need not) use the Examine Last Error Information command to learn more about the complaint. If the Positive Confirm bit is set, the write data will have been written to the remote application.

## InformationReport Request Command - 8320

The Series 90-70 PLC application can use an *InformationReport Request* command to initiate an Information Report MMS message. This service is used to inform the peer MMS application of the value of a variable. The Series 90-70 Ethernet Interface supports the InformationReport of only Named Variable objects. This is an unconfirmed service. The COMM\_REQ format of the InformationReport Request is shown in the table below.

**Table 6-22. InformationReport Request COMM\_REQ**

Parameter Description	Word Offset	Value
Word Length of MDB	0	128
Wait/NoWait Flag	1	0 (No Wait)
CRSW, Memory Type <sup>1</sup>	2	See Footnote 1
CRSW, Offset	3	0 - Max Configured
Idle Timeout Value	4	0
Maximum Communication Time	5	0
<b>CommandNumber</b>	6	8320(2080H)
Association Control Block Pointer, Memory Type <sup>1</sup>	7	See Footnote 1
Association Control Block Pointer, Offset	8	
Variable Type	9	0, 4, or 8
Length of Variable Name	10	1 - 32
Variable Name	11 - 26	characterstring
Alternate Access Index	27 - 28	
Number of Elements	29	
Variable Scope	30	0
Reserved	31	0
Reserved	32 - 47	0
InformationReportData	48 - 133	data

<sup>1</sup> Quick Reference:   Memory Type   %R   %AI   %AQ   %i   %Q   %T   %M  
                           Decimal Value   8   10   12   70   72   74   76

**Command Number** - Identifies this as an InformationReport Request command.

**Association Control Block** - The PLC address of the Association Control Block for this association.

**Variable Type** - Must contain the value 0, 4, or 8 as shown in Table 6-20.

**Length of Variable Name** - The length of the variable name in characters.

**Variable Name** - Specifies the variable whose value is to be reported.

**Alternate Access Index** - Specifies the beginning index into the array from which data is to be reported. This parameter is only used when the Variable Type parameter has a value of 8.

**Number of Elements** - Must accurately specify the number of elements to be transferred. Refer to the table below for use of this parameter.

**Table 6-23. InformationReport Element Numbers**

Variable Type	No. of Elements
0	Parameter should be 1
4	Number of Elements in the Array
8	Number of Elements Desired

**Variable Scope** - Should be set to 0 for VMD-specific scope..

**Reserved** - This parameter should be set to 0.

**InformationReport Data** - When the amount of data to be transferred is 172 octets or less, this parameter contains the actual data to be transferred.

If the amount of data is more than 172 octets, this parameter is ignored and the current content of the named variable whose attributes are specified in the request are reported. The form of the variable attributes are exactly as described for the Read and Write Request commands. The variable must exist in the local device for this request to be processed successfully. This is an unconfirmed service. A “COMM\_REQ Complete Without Error” status in the COMM\_REQ Status Word indicates that the request has been sent to the peer application.

## InformationReport Indication Service

The *InformationReport Indication Service* uses the InformationReport Indication bit (bit 14) in the Association Status Word to inform the local ladder program that an Information-Report indication has been received from the remote application and is buffered on the Ethernet Interface. To view the data from the remote application, the ladder program must issue a *Transfer InformationReport Indication Data* command. If the ladder program does not know which of several possible variables may have been sent from the remote application, it may first issue an *Examine InformationReport Indication Variable* command. If the ladder program has no interest in the variable data, it may issue a *Discard InformationReport Indication Data* command.



## Examine InformationReport Indication Variable Command - 8321

The *Examine InformationReport Indication Variable* command is used to examine the variable specification in an InformationReport indication received from a peer application. The variable name, type, and index information is returned by this service, but the variable data is not returned.

The current content of the variable specified can be placed into the local Series 90-70 PLC memory using the *Transfer InformationReport Indication Data* command described below. No other InformationReport indications can be processed until the current indication has its data transferred using the *Transfer InformationReport Indication Data* command or a *Discard Information Report Indication Data* command is issued. An *Examine InformationReport Indication Variable* command is not required prior to issuing a *Transfer InformationReport Indication Data* or *Discard InformationReport Indication Data* command if the name of the variable is of no concern.

Since this is an unconfirmed service, no response to the InformationReport is possible.

The format of the Examine InformationReport Indication Variable COMM\_REQ is shown in Table 6-9. The command number for this command is 8321 (2081H). The result of this command is that 82 octets of data will be placed at the address specified in the MDB. The format of this data is shown in the table below.

**Table 6-24. Examine InformationReport Indication Variable Data**

Parameter Description	Word Offset	Value
Data Type Code	0	See Table 6-19
Data Type Size	1	See Table 6-19
Variable Type	2	See Table 6-20
Length of Variable Name or Address	3	1 - 32
Variable Name or Address	4 - 19	Characterstring
First Index	20 - 21	0 or more
Number of Elements	22	1 or more
VariableScope	23	See Table 6-54
Length of Domain Name	24	0 - 32
DomainName	25 - 40	Characterstring

**Data Type Code** - The type code for the variable.

**Data Type Size** - The type size information for the variable, if it is available.

**Variable Type** - A code which specifies the kind of variable access that was reported.

**Length of Variable Name or Address** - The name or address information which defines the variable.

**Variable Name or Address** - The variable name or address being described.

**First Index** - The beginning index of an Alternate Access if an alternate access was received.

**Number of Elements** - The number of data elements present in the InformationReport data.

**Variable Scope** - The scope of the Variable Access if it is a Named Variable.

**Length of Domain Name** - The actual number of octets in the Domain Name.

**Domain Name** - The Name of the Domain in whose Scope the variable exists if the value of the Variable Scope parameter is Domain Specific.

## Transfer InformationReport Indication Data Command - 8330

The *Transfer InformationReport Indication Data* command is used to move the data for the variable specified in an InformationReport indication received from a peer application into the memory of the local PLC and to free the LAN Interface resources used to buffer that data. The InformationReport contains the value of a variable as known to the peer application. No other InformationReport indications can be processed until the current indication has its data transferred using the Transfer InformationReport Indication Data service or a Discard InformationReport Indication Data service is issued. The COMM\_REQ format of the Transfer InformationReport Indication Data command is shown in the table below.

Table 6-25. Transfer InformationReport Indication Data COMM\_REQ

Parameter Description	Word Offset	Value
Word Length of MDB	0	6
Wait/NoWait Flag	1	0 (No Wait)
CRSW, Memory Type <sup>1</sup>	2	See Footnote 1
CRSW, Offset	3	0 - Max Configured
Idle Timeout Value	4	0
Maximum Communication Time	5	0
<b>CommandNumber</b>	6	8330(208AH)
Association Control Block Pointer, Memory Type <sup>1</sup>	7	See Footnote 1
Association Control Block Pointer, Offset	8	
Maximum Length of Data Buffer	9	1 - 2,046
Data Buffer, Memory Type	10	See Table 6-16
Data Buffer, Offset	11	

<sup>1</sup> Quick Reference: Memory Type %R %AI%AQ %I %Q %T %M  
Decimal Value 8 10 12 70 72 74 76

**Command Number** - Identifies this as a Transfer InformationReport Indication Data command.

**Association Control Block** - The PLC address of the Association Control Block for this association.

The ACB must match an association with a pending InformationReport indication.

**Maximum Length of Data Buffer** - The Data Buffer parameter specifies where the data from the InformationReport is to be stored. If this buffer is not large enough to permit storing the reported data, the data will be truncated to fit the available buffer. The buffer length is expressed in units appropriate to the Data Buffer's memory type.

**Data Buffer** - Specifies the location where the InformationReport data is to be stored. The table below shows the format of this data.

Table 6-26. Information Report Data

Parameter Description	Word Offset
Unit Length	0
Data	1 - 1023

## Discard InformationReport Indication Data Command - 8339

The *Discard InformationReport Indication Data* command is used to discard the data for a variable specified in an InformationReport indication received from a peer application and to free the LAN Interface resources used to buffer that data. The InformationReport variable data is lost. The COMM\_REQ format of the Discard InformationReport Indication Data command is shown in the table below.

**Table 6-27. Discard InformationReport Indication Data COMM\_REQ**

Parameter Description	Word Offset	Value
Word Length of MDB	0	3
Wait/NoWaitFlag	1	0 (No Wait)
CRSW, Memory Type <sup>1</sup>	2	See Footnote 1
CRSW, Offset	3	0 - Max Configured
Idle Timeout Value	4	0
MaximumCommunicationTime	5	0
<b>CommandNumber</b>	6	8339(2093H)
AssociationControlBlockPointer, Memory Type <sup>1</sup>	7	See Footnote 1
AssociationControlBlockPointer, Offset	8	

<sup>1</sup> Quick Reference:   Memory Type   %R   %AI%AQ   %I   %Q   %T   %M  
                           Decimal Value   8    10   12   70   72   74   76

**Command Number** - Identifies this as a Discard InformationReport Indication Data command.

**Association Control Block** - The PLC address of the Association Control Block for this association.

The ACB must match an association with a pending InformationReport indication.

# Program Invocation Management Services

## PI Commands

The Start, Stop, Reset, and Resume commands permit the local ladder program to control the state of Program Invocation(s) in the remote application.

The Series 90-70 PLC has a single Program Invocation whose name is that of the Logic-master 90-70 folder from which the PLC CPU was loaded. This cannot be changed.

By default, receipt of the MMS Start, Stop, Reset, and Resume Program Invocation (PI) Indications cause the Series 90-70 PLC Run/Stop state to be changed appropriately, without any action by the local ladder program. That is, the Program Invocation object is assumed to be the entire PLC. The table below shows the effect of receipt of these PI Indications on the Series 90-70 CPU State in this default case.

If desired, the local ladder program may create a different PI object. To do so, the ladder program would issue the Set Local PI Processing services to enable ladder program handling of these Indications. When the *Set Local Program Invocation Processing* command has been successfully completed, Start, Stop, Reset, and Resume indications will be given to the ladder program and the ladder program will be responsible for modeling the Program Invocation and issuing the corresponding responses in accordance with MMS. Note that the association cannot be concluded (but can be Aborted) while any Start, Stop, Reset, or Resume Indication has not been responded to by the ladder program.

<u>MMS Indication</u>	<u>Prerequisite PI State</u>	<u>Resulting PI State</u>	<u>Default Resulting Series 90-70 CPU State</u>
Start	Idle	Running	RUN
Stop	Running	Stopped	STOP
Reset	Stopped	Idle	STOP
Resume	Stopped	Running	RUN

## Start Request Command - 8304

The Series 90-70 PLC application can use a *Start Request* command to initiate a MMS Start request. The Start Request transitions the remote application ProgramInvocation from the IDLE state into a RUNNING state. The COMM\_REQ format for the Start Request is shown in the table below.

Table 6-28. Start Request COMM\_REQ

Parameter Description	Word Offset	Value
Word Length of MDB	0	41
Wait/NoWaitFlag	1	0 (No Wait)
CRSW,Memory Type <sup>1</sup>	2	See Footnote 1
CRSW, Offset	3	0 - Max Configured
Idle Timeout Value	4	0
MaximumCommunicationTime	5	0
<b>CommandNumber</b>	6	8304(2070H)
AssociationControlBlockPointer, Memory Type <sup>1</sup>	7	See Footnote 1
AssociationControlBlockPointer, Offset	8	
Invoke ID	9 - 10	0 - 65,535
Length of ProgramInvocationName	11	1 - 32
ProgramInvocationName	12 - 27	characterstring
Length of Start Argument (IS only)	28	0 - 32
Start Argument (IS only)	29 - 44	characterstring
ProgramInvocationState,Memory Type	45	See Table 6-16
ProgramInvocationState, Offset	46	

<sup>1</sup> Quick Reference:    Memory Type    %R    %AI    %AQ    %I    %Q    %T    %M  
                                   Decimal Value    8    10    12    70    72    74    76

**Command Number** - Identifies this as a Start Request command.

**Association Control Block** - The PLC address of the Association Control Block for this association.

**Invoke ID** - The unique MMS Invocation ID.

**Length of ProgramInvocation Name** - The number of octets in the ProgramInvocation Name.

**ProgramInvocation Name** - Specifies the ProgramInvocation that is to be started.

**Length of Start Argument** - The number of characters in the Start Argument. The Start Argument parameter is optional and will not be sent if this parameter is set to zero.

**Start Argument** - An optional parameter used to pass application specific information to the Program Invocation being started.

**ProgramInvocation State** - The PLC address of the ProgramInvocation state. This parameter is returned by the MMS provider only when a Negative Response is given to the Start Request. A Negative Response will cause this word to be set to the current PI state (refer to Table 6-40) at the remote node.

## Start Indication Service

The *Start Indication Service* uses the Start Indication bit (bit 12) in the ASW to inform the ladder program that a Start Indication was received from the remote application. See the discussion of *PI Indications* for important information.

### Examine Start Indication Command - 8305

The *Examine Start Indication* command is used to examine a Start indication received at the application. The purpose of the Start is to transition the application from an IDLE state to a RUNNING state.

The format of the Examine Start Indication COMM\_REQ is shown in Table 6-9. The command number for this command is 8305 (2071H). The result of this command is that 72 octets of data will be placed at the address specified in the COMM\_REQ. The format of this data is shown in the table below.

Table 6-29. Examine Start/Resume Indication Data

Parameter Description	Word Offset	Value
Invoke ID	0 - 1	0 - 65,535
Length of ProgramInvocationName	2	1 - 32
ProgramInvocationName	3 - 18	Characterstring
LengthofStart/ResumeArgument	19	0 - 32
Start/ResumeArgument	20 - 35	characterstring

**Invoke ID** - The unique MMS Invocation ID.

**Length of ProgramInvocation Name** - The octet length of the ProgramInvocation Name.

**ProgramInvocation Name** - The name of the ProgramInvocation to be started. Any unused octets will be zero filled.

**Length of Start/Resume Argument** - The character length of the Start/Resume Argument.

**Start/Resume Argument** - Application-specific argument to be passed to the ProgramInvocation being started. Any unused octets will be zero filled. The Start/Resume Argument will not appear if MMS Version DIS 9506 is in use by the association.



## Stop Request Command - 8307

The Series 90-70 PLC ladder program can use a *Stop Request* command to initiate a MMS Stop message. Stop transitions the MMS Server ProgramInvocation from a RUNNING state into a STOPPED state. The COMM\_REQ format for the Stop Request is shown in the table below.

**Table 6-31. Stop Request COMM\_REQ**

Parameter Description	Word Offset	Value
Word Length of MDB	0	24
Wait/NoWait Flag	1	0 (No Wait)
CRSW, Memory Type <sup>1</sup>	2	See Footnote 1
CRSW, Offset	3	0 - Max Configured
Idle Timeout Value	4	0
Maximum Communication Time	5	0
<b>Command Number</b>	6	8307(2073H)
Association Control Block Pointer, Memory Type <sup>1</sup>	7	See Footnote 1
Association Control Block Pointer, Offset	8	
Invoke ID	9 - 10	0 - 65,535
Length of ProgramInvocationName	11	1 - 32
ProgramInvocationName	12 - 27	characterstring
ProgramInvocationState, Memory Type	28	See Table 6-16
ProgramInvocationState, Offset	29	

<sup>1</sup> Quick Reference:    Memory Type    %R    %AI    %AQ    %I    %Q    %T    %M  
                                   Decimal Value    8    10    12    70    72    74    76

**Command Number** - Identifies this as a Stop Request command.

**Association Control Block** - The PLC address of the Association Control Block for this association.

**Invoke ID** - The unique MMS Invocation ID.

**Length of ProgramInvocation Name** - The number of octets in the ProgramInvocation Name.

**ProgramInvocation Name** - Specifies the ProgramInvocation which is to be stopped.

**ProgramInvocation State** - The PLC address of the ProgramInvocation State. This parameter is returned by the the MMS provider only when a Negative Response is given to the Stop request. A Negative Response will cause this word to be set to the current PI state (refer to Table 6-40) at the remote node.

## Stop Indication Service

The *Stop Indication Service* uses the Stop Indication bit (bit 13) in the ASW to inform the ladder program that a Stop Indication was received from the remote application. See the discussion of *PI Indications* for important information.



## Examine Stop Indication Command - 8308

The *Examine Stop Indication* command is used to examine a Stop indication received at the application. The purpose of the Stop is to transition the application from a RUNNING state to a STOPPED state.

The format of the Examine Stop Indication COMM\_REQ is shown in Table 6-9. The command number for this command is 8308 (2074H). The result of this command is that 38 octets of data will be placed at the address specified in the MDB. The format of this data is shown in the table below.

**Table 6-32. Examine Stop/Reset Indication Data**

Parameter Description	Word Offset	Value
Invoke ID	0 - 1	0 - 65,535
Length of ProgramInvocationName	2	1 - 32
ProgramInvocationName	3 - 18	characterstring

<sup>1</sup> Quick Reference:   Memory Type   %R   %AI   %AQ   %I   %Q   %T   %M  
                           Decimal Value   8   10   12   70   72   74   76

**Invoke ID** - The unique MMS Invocation ID.

**Length of ProgramInvocation Name** - The octet length of the ProgramInvocation Name.

**ProgramInvocation Name** - The name of the ProgramInvocation to be stopped. Any unused octets will be zero filled.

## Stop Response Command - 8309

The *Stop Response* command is used to provide a response (either positive or negative) to a Stop indication. A positive response should indicate that the application has successfully transitioned into the STOPPED state. The COMM\_REQ for the Stop Response is shown in the table below.

**Table 6-33. Stop Response COMM\_REQ**

Parameter Description	Word Offset	Value
Word Length of MDB	0	5
Wait/NoWaitFlag	1	0 (No Wait)
CRSW, Memory Type <sup>1</sup>	2	See Footnote 1
CRSW, Offset	3	0 - Max Configured
Idle Timeout Value	4	0
MaximumCommunicationTime	5	0
<b>CommandNumber</b>	6	8309(2075H)
AssociationControlBlockPointer, Memory Type <sup>1</sup>	7	See Footnote 1
AssociationControlBlockPointer, Offset	8	
Positive or Negative Response	9	0, 1
Problem Code	10	See Table 6-17

<sup>1</sup> Quick Reference:    Memory Type    %R    %AI    %AQ    %I    %Q    %T    %M  
                                   Decimal Value    8    10    12    70    72    74    76

**Command Number** - Identifies this as a Stop Response command.

**Association Control Block** - The PLC address of the Association Control Block for this association.

**Positive or Negative Response** - A value of 0 indicates that a positive response should be generated. A value of 1 indicates that an error response should be issued.

**Problem Code** - An encoded value of the problem as specified in the MMS service specification. This field is ignored if a Positive Response is being sent.

## Reset Request Command - 8310

The Series 90-70 PLC application can use a *Reset Request* command to initiate a Reset MMS message. Reset transitions the MMS Server ProgramInvocation from a STOPPED state into an IDLE state. The COMM\_REQ for the Reset Request is shown in the table below.

Table 6-34. Reset Request COMM\_REQ

Parameter Description	Word Offset	Value
Word Length of MDB	0	24
Wait/NoWaitFlag	1	0 (No Wait)
CRSW, Memory Type <sup>1</sup>	2	See Footnote 1
CRSW, Offset	3	0 - Max Configured
Idle Timeout Value	4	0
MaximumCommunicationTime	5	0
<b>CommandNumber</b>	6	8310(2076H)
AssociationControlBlockPointer, Memory Type <sup>1</sup>	7	See Footnote 1
AssociationControlBlockPointer, Offset	8	
Invoke ID	9 - 10	0 - 65,535
Length of ProgramInvocationName	11	1 - 32
ProgramInvocationName	12 - 27	characterstring
ProgramInvocationState, Memory Type	28	See Table 6-16
ProgramInvocationState, Offset	29	

<sup>1</sup> Quick Reference:    Memory Type    %R    %AI    %AQ    %I    %Q    %T    %M  
                                   Decimal Value    8    10    12    70    72    74    76

**Command Number** - Identifies this as a Reset Request command.

**Association Control Block** - The PLC address of the Association Control Block for this association.

**Invoke ID** - The unique MMS Invocation ID.

**Length of ProgramInvocation Name** - The number of octets in the ProgramInvocation Name.

**ProgramInvocation Name** - Specifies the ProgramInvocation which is to be restarted.

**ProgramInvocation State** - The PLC address of the ProgramInvocation State. This parameter is returned by the the MMS provider only when a Negative Response is given to the Reset request. A Negative Response will cause this word to be set to the current PI state (refer to Table 6-40) at the remote node.

## Reset Indication Service

The *Reset Indication Service* uses the Reset Indication bit (bit 15) in the ASW to inform the ladder program that a Reset Indication was received from the remote application. See the discussion of *PI Indications* for important information.

## Examine Reset Indication Command - 8311

The *Examine Reset Indication* command is used to examine a Reset indication received at the application. The purpose of the Reset is to transition the application from a STOPPED state to an IDLE state.

The format of the Examine Reset Indication COMM\_REQ is shown in Table 6-9. The command number for this command is 8311 (2077H). The result of this command is that 38 octets of data will be placed at the address specified in the MDB. The format of this data is shown in Table 6-32.

## Reset Response Command - 8312

The *Reset Response* command is used to provide a response (either positive or negative) to a Reset indication. A positive response should indicate that the application has successfully transitioned into the IDLE state. The COMM\_REQ format for the Reset Response is shown in the table below.

Table 6-35. Reset Response COMM\_REQ

Parameter Description	Word Offset	Value
Word Length of MDB	0	5
Wait/NoWait Flag	1	0 (No Wait)
CRSW, Memory Type <sup>1</sup>	2	See Table 6-16
CRSW, Offset	3	0 - Max Configured
Idle Timeout Value	4	0
Maximum Communication Time	5	0
<b>Command Number</b>	6	8312(2078H)
Association Control Block Pointer, Memory Type <sup>1</sup>	7	See Footnote 1
Association Control Block Pointer, Offset	8	
Positive or Negative Response	9	0, 1
Problem Code	10	See Table 6-60

<sup>1</sup> Quick Reference:   Memory Type   %R   %AI   %AQ   %I   %Q   %T   %M  
 Decimal Value    8    10    12    70   72   74   76

**Command Number** - Identifies this as a Reset Response command.

**Association Control Block** - The PLC address of the Association Control Block for this association.

**Positive or Negative Response** - A value of 0 indicates that a positive response should be generated. A value of 1 indicates that an error response should be issued.

**Problem Code** - An encoded value of the problem as specified in the MMS service specification. This field is ignored if a Positive Response is being sent.

## Resume Request Command - 8313

The Series 90-70 PLC application can use a *Resume Request* command to initiate a Resume MMS message. Resume transitions the MMS Server ProgramInvocation from a STOPPED state into a RUNNING state. The COMM\_REQ format for the Resume Request is shown in the table below.

**Table 6-36. Resume Request COMM\_REQ**

Parameter Description	Word Offset	Value
Word Length of MDB	0	41
Wait/NoWait Flag	1	0 (No Wait)
CRSW, Memory Type <sup>1</sup>	2	See Footnote 1
CRSW, Offset	3	0 - Max Configured
Idle Timeout Value	4	0
Maximum Communication Time	5	0
<b>CommandNumber</b>	6	8313(2079H)
Association Control Block Pointer, Memory Type <sup>1</sup>	7	See Footnote 1
Association Control Block Pointer, Offset	8	
Invoke ID	9 - 10	0 - 65,535
Length of ProgramInvocationName	11	1 - 32
ProgramInvocationName	12 - 27	characterstring
Length of Resume Argument (IS only)	28	0 - 32
Resume Argument (IS only)	29 - 44	characterstring
ProgramInvocationState, Memory Type	45	See Table 6-16
ProgramInvocationState, Offset	46	

<sup>1</sup> Quick Reference:   Memory Type   %R   %AI   %AQ    %I   %Q    %T   %M  
                           Decimal Value   8    10    12   70   72    74   76

**Command Number** - Identifies this as a Resume Request command.

**Association Control Block** - The PLC address of the Association Control Block for this association.

**Invoke ID** - The unique MMS Invocation ID.

**Length of ProgramInvocation Name** - The number of octets in the ProgramInvocation Name.

**ProgramInvocation Name** - Specifies the ProgramInvocation which is to be resumed.

**Length of Resume Argument** - The number of characters in the Resume Argument. The Resume Argument parameter is optional and will not be sent if this parameter is set to zero.

**Resume Argument** - An optional parameter used to pass application specific information to the Program Invocation being resumed.

**ProgramInvocation State** - The PLC address of the ProgramInvocation State. This parameter is returned by the the MMS provider only when a Negative Response is given to the Resume request. A Negative Response will cause this word to be set to the current PI state (refer to Table 6-40) at the remote node.

---

## Resume Indication Service

The *Resume Indication Service* uses the Resume Indication bit (bit 2) in the ASW Extension to inform the ladder program that a Resume Indication was received from the remote application. See the discussion of *PI Indications* for important information.

### Examine Resume Indication Command - 8314

The *Examine Resume Indication* command is used to examine a Resume indication received at the application. The purpose of the Resume is to transition the application from a STOPPED state to a RUNNING state.

The format of the Examine Resume Indication COMM\_REQ is shown in Table 6-9. The command number for this command is 8314 (207AH). The result of this command is that 72 octets of data will be placed at the address specified in the MDB. The format of this data is shown in Table 6-29.

## Resume Response Command - 8315

The *Resume Response* command is used to provide a response (either positive or negative) to a Resume indication. A positive response should indicate that the application has successfully transitioned into the RUNNING state. The COMM\_REQ format for the Resume Response is shown in the table below.

**Table 6-37. Resume Response COMM\_REQ**

Parameter Description	Word Offset	Value
Word Length of MDB	0	5
Wait/NoWait Flag	1	0 (No Wait)
CRSW, Memory Type <sup>1</sup>	2	See Footnote 1
CRSW, Offset	3	0 - Max Configured
Idle Timeout Value	4	0
MaximumCommunicationTime	5	0
<b>CommandNumber</b>	6	8315 (207BH)
Association Control Block Pointer, Memory Type <sup>1</sup>	7	See Footnote 1
Association Control Block Pointer, Offset	8	
Positive or Negative Response	9	0, 1
Problem Code	10	See Table 6-60

<sup>1</sup> Quick Reference:    Memory Type    %R    %AI    %AQ    %I    %Q    %T    %M  
                                   Decimal Value    8    10    12    70    72    74    76

**Command Number** - Identifies this as a Resume Response command.

**Association Control Block** - The PLC address of the Association Control Block for this association.

**Positive or Negative Response** - A value of 0 indicates that a positive response should be generated. A value of 1 indicates that an error response should be issued.

**Problem Code** - An encoded value of the problem as specified in the MMS service specification. This field is ignored if a Positive Response is being sent.

## Set Local ProgramInvocation Processing - 8356

The Series 90-70 PLC ladder program can use the *Set Local ProgramInvocation Processing* command to control the interpretation given to the MMS service indications: Start, Stop, Reset, and Resume.

Unless this command is executed, the Ethernet Interface will intercept these MMS service indications and will start and stop the PLC as appropriate. In this case, the receipt of those indications does not cause the ASW bits to be indicated and all processing of the service request is performed by the Ethernet Interface. This is necessary since some services cause the PLC logic scan to be stopped.

If the application needs more control over the effect of these services, the Set Local ProgramInvocation Processing command can be used to enable application handling of these services. The COMM\_REQ format of the Set Local ProgramInvocation Processing command is shown in the table below.

**Table 6-38. Set Local ProgramInvocation Processing COMM\_REQ**

Parameter Description	Word Offset	Value
Word Length of MDB	0	2
Wait/NoWaitFlag	1	0 (No Wait)
CRSW,Memory Type <sup>1</sup>	2	See Footnote 1
CRSW, Offset	3	0 - Max Configured
Idle Timeout Value	4	0
MaximumCommunicationTime	5	0
<b>CommandNumber</b>	6	8356(20A4H)
ProgramInvocationProcessingOption	7	0 or not

<sup>1</sup> Quick Reference:   Memory Type   %R   %AI   %AQ    %I   %Q    %T   %M  
                           Decimal Value   8   10   12   70   72   74   76

**Command Number** - Identifies this as a Set Local ProgramInvocation Processing command.

**ProgramInvocation Processing Option** - If this value is specified as zero, default Program Invocation processing will occur -- that is, the MMS Start, Stop, Reset, and Resume services will affect the solution of the PLC logic. If this value is non-zero, these MMS services will be indicated to the application where it must be handled.



## Set Local ProgramInvocation State Command - 8355

The Series 90-70 PLC application can use a *Set Local ProgramInvocation State* command to change the state attribute of the currently executing MMS ProgramInvocation (PI) object. This allows the PI state to be accurately reflected in the MMS provider when changes due to local application action take place. The COMM\_REQ format of the Set Local ProgramInvocation State command is shown in the table below.

**Table 6-39. Set Local ProgramInvocation State COMM\_REQ**

Parameter Description	Word Offset	Value
Word Length of MDB	0	2
Wait/NoWaitFlag	1	0 (No Wait)
CRSW,Memory Type <sup>1</sup>	2	See Footnote 1
CRSW, Offset	3	0 - Max Configured
Idle Timeout Value	4	0
MaximumCommunicationTime	5	0
<b>CommandNumber</b>	6	8355(20A3H)
ProgramInvocationState	7	See Table 6-40

<sup>1</sup> Quick Reference:   Memory Type   %R   %AI   %AQ    %I   %Q    %T   %M  
                           Decimal Value   8    10    12   70   72   74   76

**Command Number** - Identifies this as a Set Local ProgramInvocation State command.

**ProgramInvocation State** - Must have one of the values given in the table below.

**Table 6-40. ProgramInvocation State Values**

Value	Meaning
0	NON-EXISTENT
1	UNRUNNABLE
2	IDLE
3	RUNNING
4	STOPPED

## Status Services

The *Status Services* are used to interrogate the VMD status information of a remote VMD. The Status Services are: *Status Request*, *Status Response*, *Status Indication*, *Status Confirm*, *UnsolicitedStatus Request*, *UnsolicitedStatus Indication*, *Examine UnsolicitedStatus Indication*, and *Set Local VMD Status*..

### Status Request Command - 8250

The PLC ladder program requests the status information of a remote application by using the *Status Request* command. The COMM\_REQ format for this command is shown in the table below.

**Table 6-41. Status Request COMM\_REQ**

Parameter Description	Word Offset	Value
Word Length of MDB	0	8
Wait/NoWait Flag	1	0 (No Wait)
CRSW, Memory Type <sup>1</sup>	2	See Footnote 1
CRSW, Offset	3	0 - Max Configured
Idle Timeout Value	4	0
MaximumCommunicationTime	5	0
<b>CommandNumber</b>	6	8250(203AH)
AssociationControlBlockPointer, Memory Type <sup>1</sup>	7	See Footnote 1
AssociationControlBlockPointer, Offset	8	
Invoke ID	9 - 10	0 - 65,535
Maximum Length of Status Buffer	11	4 - 20
Status Buffer, Memory Type	12	See Table 6-16
Status Buffer, Offset	13	

<sup>1</sup> Quick Reference:   Memory Type   %R   %AI   %AQ   %I   %Q   %T   %M  
                           Decimal Value   8   10   12   70   72   74   76

**Command Number** - Identifies this as a Status Request command.

**Association Control Block** - The PLC address of the Association Control Block for this association.

**Invoke ID** - The unique MMS Invocation ID.

**Maximum Length of Status Buffer** - The Length of Status Buffer parameter should be set to the maximum number of octets that can be used to hold the returned status information. If the length specified is insufficient to return all of the data, only the specified number of octets is returned and a truncation indication (most significant bit of the length) is given.

**Status Buffer** - The PLC address of a buffer of four or more words where the octets of a status buffer are to be stored. No more octets than are specified in the Maximum Length of Status Buffer parameter will be used.

The Status Buffer contains information regarding the remote VMD status as shown in Table 6-43.

## Status Indication Service

The *Status Indication Service* uses the Status Indication bit (bit 11) of the Association Status Word to indicate that the remote application requested status of the local PLC. When indicated, the ladder program should issue the *Status Response* command.

## Status Response Command - 8251

The *Status Response* command is used to respond to a request for status information. The reception of a Status Indication is indicated by the Status Indication (bit 11) of the ACB Association Status Word. The response to the indication may be either positive or negative in nature. The COMM\_REQ format for the Status Response command is shown in the table below.

Table 6-42. Status Response COMM\_REQ

Parameter Description	Word Offset	Value
Word Length of MDB	0	14
Wait/NoWaitFlag	1	0 (No Wait)
CRSW, Memory Type <sup>1</sup>	2	See Footnote 1
CRSW, Offset	3	0 - Max Configured
Idle Timeout Value	4	0
MaximumCommunicationTime	5	0
<b>CommandNumber</b>	6	8251 (203BH)
AssociationControlBlockPointer, Memory Type <sup>1</sup>	7	See Footnote 1
AssociationControlBlockPointer, Offset	8	
Positive or Negative Response	9	0, 1
ProblemCode	10	See Table 6-60
Length of Status Local Detail	11	0 - 16
Status Local Detail	12 - 19	Applicationspecific

<sup>1</sup> Quick Reference: Memory Type %R %AI %AQ %I %Q %T %M  
 Decimal Value 8 10 12 70 72 74 76

**Command Number** - Identifies this as a Status Response command.

**Association Control Block** - The PLC address of the Association Control Block for this association.

**Positive or Negative Response** - Indicates whether the request for status was accepted. If this parameter is 0, then the request is accepted, and a Positive Response is sent to the requesting application. If this parameter is 1, then the request is rejected, and a Negative Response is sent to the requesting application.

**Problem Code** - Indicates the nature of the problem if the Positive or Negative Response parameter is 1 (request was unsuccessful).

**Length of Status Local Detail** - This is the number of octets in the Status Local Detail.

**Status Local Detail** - Can be used to convey additional information about the VMD status to the requesting application. The VMD Logical Status and the VMD Physical Status will be set by the Ethernet Interface software (assuming a Positive Response).

## Status Confirm Service

The *Status Confirm Service* uses the Positive and Negative Confirm bits in the Association Status Word of the ACB. This service determines whether the request for status information from the remote application was successful. If the request was successful, the status data from the remote application is in the Status Buffer specified in the status request MDB. The status data has the following format:

**Table 6-43. Status Buffer**

Use	Word Offset	Value
LocalDetail Octet Length	0	0 - 16
(Most Significant 8 Bits) VMD Logical Status	1	See Table 6-47
(Least Significant 8 bits) VMD Physical Status		See Table 6-48
First 16 octets of Status Local Detail if it is present	2 - 9	Device Specific

## Unsolicited Status Request - 8252

The *Unsolicited Status* services are used to report status changes in the local VMD which may not otherwise be apparent to the remote application. The two Unsolicited Status services are: *UnsolicitedStatus Request*, and *Examine UnsolicitedStatus Indication*.

The *UnsolicitedStatus Request* command is used to send the local VMD status to the remote peer. The UnsolicitedStatus Request is an unconfirmed service. The COMM\_REQ format for the UnsolicitedStatus Request command is shown in the table below.

**Table 6-44. UnsolicitedStatus Request COMM\_REQ**

Parameter Description	Word Offset	Value
Word Length of MDB	0	12
Wait/NoWait Flag	1	0 (No Wait)
CRSW, Memory Type <sup>1</sup>	2	See Footnote 1
CRSW, Offset	3	0 - Max Configured
Idle Timeout Value	4	0
Maximum Communication Time	5	0
<b>Command Number</b>	6	8252(203CH)
Association Control Block Pointer, Memory Type <sup>1</sup>	7	See Footnote 1
Association Control Block Pointer, Offset	8	
Length of Status Local Detail	9	0 - 16
Status Local Detail	10 - 17	Application specific

<sup>1</sup> Quick Reference:   Memory Type   %R   %AI   %AQ   %I   %Q   %T   %M  
                           Decimal Value   8   10   12   70   72   74   76

**Command Number** - Identifies this as an Unsolicited Status Request command.

**Association Control Block** - The PLC address of the Association Control Block for this association.

**Length of Status Local Detail** - The number of octets in the Status Local Detail.

**Status Local Detail** - The application-specific Status Local Detail can be used to convey additional information about the VMD. The VMD Logical Status and the VMD Physical Status will be set by the Ethernet Interface software.

## Unsolicited Status Indication Service

The *Unsolicited Status Indication Service* uses the Unsolicited Status Indication bit (bit 10) of the ASW to indicate that the remote application sent Unsolicited Status. When indicated, the ladder program should issue an *Examine Unsolicited Status Indication* command.

### Examine UnsolicitedStatus Indication Command - 8253

The *Examine UnsolicitedStatus Indication* command requests that the unsolicited status information from a remote application be transferred into the memory of the Series 90-70 PLC. This indication is detected by bit 10 of the ACB Association Status Word. The COMM\_REQ format for this command is shown in the table below.

**Table 6-45. Examine UnsolicitedStatus Indication COMM\_REQ**

Parameter Description	Word Offset	Value
Word Length of MDB	0	6
Wait/NoWait Flag	1	0 (No Wait)
CRSW, Memory Type <sup>1</sup>	2	See Footnote 1
CRSW, Offset	3	0 - Max Configured
Idle Timeout Value	4	0
Maximum Communication Time	5	0
<b>Command Number</b>	6	8253(203DH)
Association Control Block Pointer, Memory Type <sup>1</sup>	7	See Footnote 1
Association Control Block Pointer, Offset	8	
Maximum Length of Status Buffer	9	4 - 20
Status Buffer, Memory Type	10	See Table 6-16
Status Buffer, Offset	11	

<sup>1</sup> Quick Reference:    Memory Type    %R    %AI    %AQ    %I    %Q    %T    %M  
                                   Decimal Value    8    10    12    70    72    74    76

**Command Number** - Identifies this as an Examine UnsolicitedStatus Indication command.

**Association Control Block** - The PLC address of the Association Control Block for this association.

**Maximum Length of Status Buffer** - Should be set to the maximum number of octets that can be used to hold the status information.

**Status Buffer** - The PLC address of a buffer of two or more words where the octets of the status are to be stored. No more octets than are specified in the Length of Status Buffer parameter will be used.

The format of the data returned by this command is shown in Table 6-43.

## Set Local VMD Status Command - 8353

The Series 90-70 PLC application can use a *Set Local VMD Status* command to change the state of the VMD Logical Status and the VMD Physical Status as reflected in the MMS provider. This service should always be used to update the VMD status whenever it changes due to local application action. These status values restrict the types of MMS services which can be acted upon and should be accurate at all times. The COMM\_REQ format for the Set Local VMD Status command is shown in the table below.

**Table 6-46. Set Local VMD Status COMM\_REQ**

Parameter Description	Word Offset	Value
Word Length of MDB	0	3
Wait/NoWait Flag	1	0 (No Wait)
CRSW, Memory Type <sup>1</sup>	2	See Footnote 1
CRSW, Offset	3	0 - Max Configured
Idle Timeout Value	4	0
Maximum Communication Time	5	0
<b>Command Number</b>	6	8353(20A1H)
VMD Logical Status	7	See Table 6-47
VMD Physical Status	8	See Table 6-48

<sup>1</sup> Quick Reference:   Memory Type   %R   %AI   %AQ   %i   %Q   %T   %M  
                           Decimal Value   8   10   12   70   72   74   76

**Command Number** - Identifies this as a Set Local VMD Status command.

**VMD Logical Status** - Must have one of the values given in the table below.

**Table 6-47. VMD Logical Status Values**

Value	Meaning
0	STATE-CHANGESALLOWED
1	NO-STATE-CHANGESALLOWED
2	LIMITED-SERVICES-AVAILABLE
3*	SUPPORT-SERVICESALLOWED

ISO IS 9506 (MMS version 1) only.

**VMD Physical Status** - Must have one of the values given in Table 6-48.

**Table 6-48. VMD Physical Status Values**

Value	Meaning
0	OPERATIONAL
1	PARTIALLY-OPERATIONAL
2	INOPERABLE
3	NEEDS-COMMISSIONING

The MMS provider will initialize the logical and physical VMD statuses based on its ability to communicate with the Series 90-70 PLC. If the PLC is accessible and running, the status values will be STATE-CHANGES-ALLOWED and OPERATIONAL. If the PLC is accessible and stopped, the status values will be STATE-CHANGES-ALLOWED and PARTIALLY-OPERATIONAL. If communication with the PLC cannot be established, the values will be LIMITED-SERVICES-PERMITTED and INOPERABLE. Anytime the PLC transitions between running and stopped states, the VMD status is updated to reflect the PLC's current state. Using the Set Local VMD Status command overrides the VMD statuses as maintained by the MMS provider.

## Miscellaneous OSI Services

The *Identify Services* are used to interrogate the identity of a remote MMS VMD. The two Identify services are: Identify Request and Identify Confirm.

### Identify Request Command - 8240

The PLC ladder program requests identifying information from a remote application by using the *Identify Request* command. The COMM\_REQ format for this command is shown in the table below.

**Table 6-49. Identify Request COMM\_REQ**

Parameter Description	Word Offset	Value
Word Length of MDB	0	7
Wait/NoWait Flag	1	0 (No Wait)
CRSW, Memory Type <sup>1</sup>	2	See Footnote 1
CRSW, Offset	3	0 - Max Configured
Idle Timeout Value	4	0
Maximum Communication Time	5	0
<b>Command Number</b>	6	8240(2030H)
Association Control Block Pointer; Memory Type <sup>1</sup>	7	See Footnote 1
Association Control Block Pointer; Offset	8	
Invoke ID	9 - 10	0 - 65,535
Data Buffer; Memory Type	11	See Table 6-16
Data Buffer; Offset	12	

<sup>1</sup> Quick Reference:      Memory Type    %R   %AI   %AQ   %I   %Q   %T   %M  
                                   Decimal Value    8    10    12   70   72   74   76

**Command Number** - Identifies this as an Identify Request command.

**Association Control Block** - The PLC address of the Association Control Block for this association.

**Invoke ID** - The unique MMS Invocation ID.

**Data Buffer** - The PLC address of where the remote peer application's identification information is to be put. This buffer must be able to accommodate 102 octets of data. See the Table 6-50 for data format.



## Identify Confirm Service

The *Identify Confirm Service* uses the Positive and Negative Confirm bits in the ACB. This service determines whether the request for identification information was successful.

When the Negative Confirm bit is set, the Problem Code in the ACB is updated with the reason for the negative confirm. If the confirm is positive, the identification information will have been placed in the location specified by the Identify Request.

The format for the returned data is shown in the table below.

**Table 6-50. Identify Positive Confirm Data**

Parameter Description	Word Offset	Value
Length of Vendor Name	0	1 - 32
Vendor Name	1 - 16	characterstring
Length of Model Name	17	1 - 32
Model Name	18 - 33	characterstring
Length of Revision	34	1 - 32
Revision	35 - 50	characterstring

**Length of Vendor Name** - The octet length of the Vendor Name string.

**Vendor Name** - An ASCII string representing the remote peer application's Vendor Name ("GE Fanuc Automation", for example). Unused octets will be set to 0.

**Length of Model Name** - The octet length of the Model Name string.

**Model Name** - An ASCII string representing the remote peer application's Model Name ("Series 90-70 PLC", for example). Unused octets will be set to 0.

**Length of Revision** - The octet length of the Revision string.

**Revision** - An ASCII string representing the remote peer application's VMD executive revision value ("CPU Microcode Version 2.01", for example). Unused octets will be 0.

In ISO IS 9506, there is an additional parameter returned with the Identify Confirm: the list of abstract syntaxes supported. ISO 9506 specifies that "The abstract syntax defined in ISO 9506 shall not be included in this list". Since that is the only abstract syntax that the Ethernet Interfaces support, no other abstract syntaxes will be meaningful. Therefore, we have chosen to omit this parameter from the information returned to the ladder program from any Identify Confirm.

## Cancel Request Command - 8290

The *Cancel Request* command is provided to allow an application to cause the orderly termination of a service that is pending for execution. The COMM\_REQ format for the Cancel Request is shown in the table below.

**Table 6-51. Cancel Request COMM\_REQ**

Parameter Description	Word Offset	Value
Word Length of MDB	0	5
Wait/NoWait Flag	1	0 (No Wait)
CRSW, Memory Type <sup>1</sup>	2	See Footnote 1
CRSW, Offset	3	0 - Max Configured
Idle Timeout Value	4	0
MaximumCommunicationTime	5	0
<b>CommandNumber</b>	6	8290(2062H)
AssociationControlBlockPointer, Memory Type <sup>1</sup>	7	See Footnote 1
AssociationControlBlockPointer, Offset	8	
OriginalInvoke ID	9 - 10	0 - 65,535

<sup>1</sup> Quick Reference:    Memory Type    %R    %AI    %AQ    %I    %Q    %T    %M  
                           Decimal Value    8    10    12    70    72    74    76

**Command Number** - Identifies this as a Cancel Request command.

**Association Control Block** - The PLC address of the Association Control Block for this association.

**Original Invoke ID** - Specifies the particular transaction which the PLC ladder program wishes to cancel.

The COMM\_REQ Complete With Error code in the CRSW will appear if the original transaction has already completed. Otherwise, the ACB Positive or Negative Confirm bit will turn on upon the completion of the particular service which was canceled. A successfully canceled service will return a negative confirm.

## Get Remote Name List Command - 8301

The Series 90-70 PLC application can use a *Get Remote Name List* command to ask that all object names of a desired object class and scope in a remote peer application be returned. The COMM\_REQ format for the GetRemoteName List command is shown in the table below.

**Table 6-52. Get Remote Name List COMM\_REQ**

Parameter Description	Word Offset	Value
Word Length of MDB	0	44
Wait/NoWaitFlag	1	0 (No Wait)
CRSW, Memory Type <sup>1</sup>	2	See Footnote 1
CRSW, Offset	3	0 - Max Configured
Idle Timeout Value	4	0
MaximumCommunicationTime	5	0
<b>CommandNumber</b>	6	8301(206DH)
AssociationControlBlockPointer, Memory Type <sup>1</sup>	7	See Footnote 1
AssociationControlBlockPointer, Offset	8	
Invoke ID	9 - 10	0 - 65,535
Object Class	11	See Table 6-53
Object Scope	12	See Table 6-54
Length of Continue After Name	13	0 - 32
Continue After Name	14 - 29	characterstring
Maximum Length of Name Buffer	30	0 - 1020
Length of Domain Name	31	0 - 32
DomainName	32 - 47	characterstring
Name Buffer, Memory Type	48	See Table 6-16
Name Buffer, Offset	49	

<sup>1</sup> Quick Reference:   Memory Type   %R   %AI   %AQ   %I   %Q   %T   %M  
                           Decimal Value   8   10   12   70   72   74   76

**Command Number** - Identifies this as a Get Remote Name List Request command.

**Association Control Block** - The PLC address of the Association Control Block for this association.

**Invoke ID** - The unique MMS Invocation ID.

**Object Class** - The class of MMS object for which a list is desired.

**Table 6-53. Object Class Values**

Value	Object Class
0	Named Variable
1	ScatteredAccess
2	Named VariableList
3	Named Type
4	Semaphore
5	EventCondition
6	Event Action
7	EventEnrollment
8	Journal
9	Domain
10	ProgramInvocation
11	OperatorStation

**Object Scope** - The scope over which the MMS object is defined.

**Table 6-54. Object Scope Values**

Value	Object Scope
0	VMDspecific
1	Domainspecific
2	Applicationassociationspecific

**Length of Continue After Name** - Should be set to the number of characters in the Continue After Name parameter. If the Length of Continue After Name parameter is set to zero, names are retrieved beginning with the first name in the list.

**Continue After Name** - This string can be used to begin retrieving names from a point other than at the beginning of the list. Names are stored in alphabetical order to facilitate getting a partial list.

**Maximum Length of Name Buffer** - The list of names is returned in the Name Buffer parameter as a sequence of NULL terminated strings. The Length of Name Buffer parameter should be set to the maximum number of octets that can be used to hold the Name Buffer parameter. If the length specified is insufficient to return all of the data, only the specified number of octets is returned and a truncation indication (most significant bit of the length) is given.

**Length of Domain Name** - Specifies the number of characters in the name for the domain in whose scope the requested Object Names should reside. A zero (0) on this field indicates no domain name associated with the objects.

**Domain Name** - Is used to specify the name of the domain associated with a request using the Domain Specific value for Object Scope. Unless a Domain Specific scope is specified, this parameter is ignored.

**Name Buffer** - The PLC address of a buffer of one or more words where the octets of the Name Buffer parameter are to be stored. No more octets than are specified in the Maximum Length of Name Buffer parameter will be used.

The data written into the specified Name Buffer PLC address will actually contain 4 octets more than the Maximum Length of Name Buffer parameter indicates. The format of the data returned is shown in the table below.

Table 6-55. Get Remote Name List Data

Parameter Description	Word Offset	Value
Number of Object Names	0	non-negative
Object Name List Length	1	0 - 1,020
Object Name List	2 - 511	characterstrings

**Number of Object Names** - A count of the number of Object Names returned from the remote peer application.

**Object Name List Length** - Octet length of the Object Name List. This value will not exceed the amount in the Maximum Length of Name Buffer parameter in the COMM\_REQ.

**Object Name List** - A list of NULL-terminated ASCII character strings. Each string is the name of an object of the specified type. No partial names will be returned. If the data is being put into Word Memory (%R, %AI, %AQ), an even number of bytes will be written.

## Error Request Command - 8350

The Series 90-70 PLC application can use an *Error Request* command to cause an MMS Confirmed Error service to be sent to the remote peer. This service may be used as a general Negative Response for any MMS indication for which a “xxx Response” COMM\_REQ command exists. The COMM\_REQ format of the Error Request is shown in the table below.

Table 6-56. Error Request COMM\_REQ

Parameter Description	Word Offset	Value
Word Length of MDB	0	6
Wait/NoWait Flag	1	0 (No Wait)
CRSW, Memory Type <sup>1</sup>	2	See Footnote 1
CRSW, Offset	3	0 - Max Configured
Idle Timeout Value	4	0
Maximum Communication Time	5	0
<b>CommandNumber</b>	6	8350(209EH)
Association Control Block Pointer; Memory Type <sup>1</sup>	7	See Footnote 1
Association Control Block Pointer; Offset	8	
Invoke ID	9 - 10	0 - 65,535
Problem Code	11	See Table 6-60

<sup>1</sup> Quick Reference:    Memory Type    %R   %AI   %AQ    %I   %Q   %T   %M  
                           Decimal Value    8    10    12    70   72   74   76

**Command Number** - Identifies this as an Error Request command.

**Association Control Block** - The PLC address of the Association Control Block for this association.

**Invoke ID** - The unique MMS Invocation ID.

**Problem Code** - An encoded value of the problem as specified in the MMS service specification.

## Reject Indication Service

The *Reject Indication Service* uses the Reject Indication bit (bit3) in the ASW Extension to indicate that either the local Ethernet Interface or the remote application could not parse (understand) a Request issued by the ladder program; i.e., the Request was not constructed properly. The ladder program may (but need not) use the Examine Reject Indication command to learn more about the complaint.

### Examine Reject Indication Command - 8351

The Series 90-70 PLC application can use an *Examine Reject Indication* command to look at the details of the last MMS Reject received on the association. This COMM\_REQ will receive a "Complete With Error" code in the CRSW unless ASWE bit #3 is ON.

The format of the Examine Reject Indication COMM\_REQ is shown in Table 6-9. The command number for this command is 8351 (209FH). The result of this command is that 10 octets of data will be placed at the address specified in the MDB. The format of this data is shown in the table below.

Table 6-57. Examine Reject Indication Data

Parameter Description	Word Offset	Value
Invoke ID	0 - 1	0 - 65,535
Reject Class	2	See Table 6-62
Reject Code	3	See Table 6-62
GeneratedLocally	4	0 or not

**Invoke ID** - The unique MMS Invocation ID of the Request that was rejected.

**Reject Class** - Specifies the general category of the problem that was detected.

**Reject Code** - Identifies the specific problem, given the Reject Class.

**Generated Locally** - If set to 0, the MMS Reject was received from the remote peer application. If not set to 0, then the reject was issued by the MMS Provider in the local Ethernet Interface.

## Error Indication Service

The *Error Indication Service* uses the Error Indication bit (bit 4) of the ASW Extension to indicate that the remote application was able to parse (understand), but could not provide the service requested in a Request issued by the ladder program.

## Examine Last Error Information Command - 8352

The Series 90-70 PLC ladder program can use an *Examine Last Error Information* command to look at the details of the last MMS error received on the association. The error information will be saved any time either the Negative Confirm bit of the ASW or the Error Indication bit of the ASWE are set to the value 1.

The format of the Examine Last Error Information COMM\_REQ is shown in Table 6-9. The command number for this command is 8352 (20A0H). The result of this command is that 184 octets of data will be placed at the address specified in the MDB. The format of this data is shown in the table below.

**Table 6-58. Examine Last Error Information Data**

Parameter Description	Word Offset	Value
Invoke ID	0 - 1	0 - 65,535
ErrorClass	2	See Table 6-60
Error Code	3	See Table 6-60
AdditionalError	4 - 5	Applicationspecific
Length of Description Buffer	6	0 - 170
DescriptionBuffer	7 - 91	Applicationspecific

**Invoke ID** - The unique MMS Invocation ID of the Request in error.

**Error Class** - Specifies the general category of the error that was detected.

**Error Code** - Identifies the specific problem, given the Error Class.

**Additional Error** - A 4-octet integer not otherwise constrained.

**Length of Description Buffer** - The octet length of the Description Buffer.

**Description Buffer** - An optional string of bits giving diagnostic information. Any unused octets will be zero filled.

## Define Application Command - 8200

The *Define Application Service* is used by the ladder program to specify an Application Common Name which is the name of the OSI 7-layer Application Interface running on the Series 90-70 PLC.

Upon Ethernet Interface restart, the AP for the Series 90-70 PLC application is always defined by the configuration parameter *applcnam*. This command overrides the configuration parameter *applcnam* until the next restart occurs. This command does not permanently change the configuration parameter *applcnam*.

The COMM\_REQ format for the *Define Application* command is shown in the table below.

**Table 6-59. Define Application COMM\_REQ**

Parameter Description	Word Offset	Value
Word Length of MDB	0	35
Wait/NoWait Flag	1	0 (No Wait)
CRSW, Memory Type <sup>1</sup>	2	See Footnote 1
CRSW, Offset	3	0 - Max Configured
Idle Timeout Value	4	0
MaximumCommunicationTime	5	0
<b>CommandNumber</b>	6	8200(2008H)
Reserved	7	
Length of Application Common Name	8	1 - 64
ApplicationCommonName	9 - 40	characterstring

<sup>1</sup> Quick Reference:    Memory Type    %R    %AI    %AQ    %I    %Q    %T    %M  
                           Decimal Value    8    10    12    70    72    74    76

**Command Number** - Identifies this as a Define Application command.

**Length of Application Common Name** - The number of octets in the common name.

**Application Common Name** - A character string indicating the Application Common Name. Any character from the ISO 646 Printable Character set may be used.



## MMS Error Encodings

The table below shows the allowed values for the *MMS Error Services*. The Error Class and the Error Code are encoded in the Problem Code parameter of Response COMM\_REQs by using the formula:

$$PC = (EC * 256) + ER$$

Notice that the Problem Code encoding simply consists of placing the hexadecimal value of the Error Class in the most significant octet and the hexadecimal value of the Error Code in the least significant octet of the Problem Code word.

### Note

Using values other than those shown in the following table will result in a reject of the error that is sent.

**Table 6-60. MMS Error Values**

Class	Code	Meaning	Class	Code	Meaning
0	0	VMD-state	6	0	time-resolution
	1	other		1	other
	2	vmd-state-conflict	7	1	unsupportable-time-resolution
	3	vmd-operational-problem		0	access
	4	domain-transferproblem		1	other
1	0	state-machine-id-invalid	2	object-access-unsupported	
	1	application-reference	3	object-non-existent	
	2	other	4	object-access-denied	
	3	application-unreachable	8	4	object-invalidated
	4	connection-lost		0	initiate
2	0	application-reference-invalid	1	other	
	1	context-unsupported	2	version-incompatible	
	2	definition	3	max-segment-insufficient	
	3	other	4	max-services-outstanding-calling-insufficient	
	4	object-undefined	5	max-services-outstanding-called-insufficient	
	5	invalid-address	6	service-CBB-insufficient	
	6	type-unsupported	9	7	parameter-CBB-insufficient
6	type-inconsistent	0		nesting-level-insufficient	
3	0	object-exists	1	conclude	
	1	object-attribute-inconsistent	0	other	
	0	resource	1	further-communication-required	
	1	other	10	0	cancel
	2	memory-unavailable		1	other
	3	processor-resource-unavailable	2	invoke-id-unknown	
4	0	mass-storage-unavailable	11	0	file
	1	capability-unavailable		1	other
	2	capability-unknown	2	filename-ambiguous	
	3	service	3	file-busy	
	4	other	4	filename-syntax-error	
	5	primitives-out-of-sequence	5	content-type-invalid	
5	0	object-state-conflict	6	position-invalid	
	1	pdu-size	7	file-access-denied	
	2	continuation-invalid	ff	file-non-existent	
	3	object-constraint-conflict	fe	Bad data format at local station	
5	0	service preempt	ff	PLC transfer error at local station	
	1	other			
	2	timeout			
	3	deadlock			
		cancel			

In addition to the above error codes that may be received or sent (via COMM\_REQ), the following error codes may be received when data access errors occur on outgoing requests.

**Table 6-61. Data Access Errors**

Class	Hexadecimal Code	Meaning
80H	0	Object invalidated
	1	Hardware fault
	2	Temporarily unavailable
	3	Object access denied
	4	Object undefined
	5	Invalid address
	6	Type unsupported
	7	Type inconsistent
	8	Object attribute inconsistent
	9	Object access unsupported
	A	Object does not exist

The table below shows the MMS Reject values and their meaning. The Reject Class and Reject Code identify the type of error encountered.

**Table 6-62. MMS Reject Values**

Class	Code	Meaning	Class	Code	Meaning			
1	0 1 2 3 4 5 6 7 8 9	Confirmed-request unspecified error unrecognized service unrecognized modifier invalid Invoke Id invalid argument invalid modifier maximum services outstanding exceeded maximum segment length exceeded maximum recursion exceeded value out of range	5	0	PDU error			
				1	unspecified error invalid PDU			
			6	0	cancel request			
				1	unspecified error invalid Invoke Id			
			7	0	cancel response			
				1	unspecified error invalid Invoke Id			
			8	0 1 2 3	cancel error	8	0	unspecified error
							1	invalid Invoke Id
							2	invalid service error
9	0 1	value out of range	9	0	conclude request			
				1	unspecified error invalid argument			
				10	conclude response			
3	0 1 2 3 4	confirm error unspecified error unrecognized service invalid Invoke Id invalid service error value out of range	11	0	conclude error			
				1	unspecified error invalid service error value out of range			
			11	1	conclude error			
				2	unspecified error invalid service error value out of range			
4	0 1 2 3 4	unconfirmed PDU unspecified error unrecognized service invalid argument maximum recursion exceeded value out of range						

# Chapter 7

## Station Manager COMMunications REQuests

---

---

This chapter contains information about how to program COMMunication REQuests (COMM\_REQs) for the Station Manager commands supported through ladder logic. These requests allow the ladder logic program within the PLC to retrieve some of the same information available through the Station Manager.

For more information on Station Manager commands and ladder logic programming refer to the following chapters in this manual.

- Chapter 4 describes the Station Manager commands supported locally over the serial port and remotely over the LAN.
- Chapter 5 provides general instructions on programming a COMM\_REQ.

### Station Manager Ladder Requests

There are four Station Manager commands implemented in the PLC ladder logic. The table below lists these commands.

Table 7-1. Station Manager PLC Commands

Station Manager Command	Command Number	
	decimal	(hexadecimal)
Retrieve Extended Status Buffer Request	08100	(1FA4)
Retrieve Tallies Request	08101	(1FA5)
Retrieve Log Events Request	08102	(1FA6)
Restart Ethernet Interface	08103	(1FA7)

## Retrieve Extended Status Buffer Request - 8100

The Retrieve Extended Status Buffer request, copies the current value of the Extended Status Buffer maintained by the Ethernet Interface software into a set of words in the requesting PLC. The Extended Status Buffer contains diagnostic information about requests which receive a “COMM\_REQ Complete With Error” status. This information can be used to help find the reason for the error status returned.

The COMM\_REQ for the Retrieve Extended Status Buffer is described below.

**Table 7-2. Retrieve Extended Status Buffer Request COMM\_REQ**

Parameter Description	Word Offset	Value
Word Length of MDB	0	4
Wait/NoWait Flag	1	0 (No Wait)
CRSW, Memory Type	2	See Table 5-2 <sup>1</sup>
CRSW, Offset	3	
Idle Timeout Value	4	0
Maximum Communication Time	5	0
<b>Command Number</b>	6	8100 (1FA4H)
Data Buffer, Memory Type	7	See Table 6-42 <sup>1</sup>
Data Buffer, Offset	8	
Maximum Word Length	9	1-14

<sup>1</sup> Quick Reference:   Memory Type   %R   %AI   %AQ   %i   %Q  
                           Decimal Value   8   10   12   70   72

**Command Number** - Identifies this as a Retrieve Extended Status Buffer Request command.

**Data Buffer** - PLC address of where the Extended Status data is to be put.

**Maximum Word Length** - The maximum number of words to be transferred. It requires 14 words to hold all the data. A maximum length greater than 13 will cause 14 words to be transferred.

The format of the Extended Status Buffer data is shown below:

**Table 7-3. Extended Status Buffer Data**

Entry	Use
1	Last Command
2	(Reserved)
3	Last Station Manager Command
4	Software Version
5	PROM Version
6	Error Code
7 - 14	Last MDB in error

**Last Command:** The Last Command word contains the command value of the last communication command that was issued.

---

**Last Station Manager Command:** The Last Station Manager Command word contains the command value of the last Station Manager command that was issued from the ladder program.

**Software Version:** The Software Version word contains a two-byte value which identifies the version of system software running in the Ethernet Interface. This value will change on every release of Ethernet Interface software.

**PROM Version:** The PROM Version word contains a two-byte value which identifies the version of PROM software running in the Ethernet Interface.

**Error Code:** The Error Code word contains a descriptive diagnostic code which gives a more detailed reason for the “COMM\_REQ Complete With Error” status returned for the last command in error. Refer to Chapter 8 for a complete list of error codes.

**Last MDB In Error:** The Last MDB in the Error field contains the first eight (8) words of the Message Definition Block (MDB) associated with the last COMM\_REQ which received an error.

## Retrieve Tallies Request - 8101

The Retrieve Tallies request copies portions of the system tallies for the local station into a block of words specified in the request. This request provides access by the ladder program to all tallies except the MAC layer tallies.

### Note

By their nature, the number and significance of system tallies change from version to version of software. Care must be taken when processing tallies to be sure that the proper format is being used for the data retrieved.

The COMM\_REQ for the Retrieve Tallies Request is described below.

Table 7-4. Retrieve Tallies Request COMM\_REQ

Parameter Description	Word Offset	Value
Word Length of MDB	0	5
Wait/NoWait Flag	1	0 (No Wait)
CRSW Memory Type	2	See Table 5-2 <sup>1</sup>
CRSW Offset	3	
Idle Timeout Value	4	0
Maximum Communication Time	5	0
<b>Command Number</b>	6	8101 (1FA5H)
Data Buffer, Memory Type	7	See Table 6-41 <sup>1</sup>
Data Buffer, Offset	8	
Maximum Word Length	9	1-138
Initial Tally Value	10	0-138

<sup>1</sup> Quick Reference: Memory Type %R %AI %AQ %I %Q  
Decimal Value 8 10 12 70 72

**Command Number** - Identifies this as a Retrieve Tallies Request command.

**Data Buffer** - PLC address of where the tally data is to be put.

**Maximum Word Length** - The maximum number of words to be transferred. Each tally in Table 7-5 requires one word of PLC memory.

**Initial Tally Value** - One of the tally offsets from Table 7-5.

The following table contains the names of the tallies and their associated offsets. Each tally entry is 2 bytes in length.

**Table 7-5. Tallies Structure and Offsets**

Tally	Offset	Tally	Offset	Tally	Offset
<b>System</b>		<b>ACSE</b>		<b>Network</b>	
TimReset	0	RejRcvd	43	DscGen	81
Restart	1	RejSent	44	DscCong	82
<b>MAC</b>		ARejRcvd	45	DscAddr	83
SQEErr	3	ARejSent	46	DscLife	84
MisdPack	4	AbrtRcvd	47	DscUnsp	85
FrameErr	6	AbrtSent	48	DscReasm	86
SuccOne	7	PAbort	49	PduRcvd	87
CrcErr	8	PReject	50	PduSent	88
RbufErr	9	<b>Presentation</b>		OctSent	89
LateColl	12	PCprRcvd	51	OctRcvd	90
LosyCarr	13	PCprSent	52	EsEsSent	91
BsyCar	14	CprTRcvd	53	EsIsSent	92
NoRtry	15	CprPRcvd	54	EsEsRcvd	93
SuccMore	16	CprTSent	55	EsIsRcvd	94
FRtry	17	CprPSent	56	EsEsErr	95
<b>Data Link</b>		ArpSent	57	<b>Distributed Directory Protocol</b>	
UnReg	18	ArpErr	58	RegSnt	107
Lsap0	19	<b>Session</b>		UnregSnt	108
LsapOfI	20	RfRcvd	59	RegRcv	109
EthUnReg	21	RfSent	60	UnRegRcv	110
MacErr	22	RfPRcvd	61	RslvSent	111
Llc3Nak	133	RfPSent	62	RslvRcvd	112
mmImpRej	134	RfTRcvd	63	RslvRsp	113
TstRcvd	25	AbRcvd	64	NameConf	114
TstResp	26	AbSent	65	BrwseSnt	115
<b>PLC Driver</b>		AbPSent	66	BrwseRcv	116
PlcQFull	29	<b>Transport</b>		<b>MMS Provider</b>	
PlcSweep	30	CrCong	67	MsgSent	137
MsgRcv	31	CrConfig	68	MsgRcvd	138
PlcReq	32	CrRefCfg	69	RejSent	139
PlcAbt	33	CrProErr	70	RejRcvd	140
MsgSent	34	CrUnsuc	71	RegFail	141
MyAbt	35	PduProEr	72	BldFail	142
Write	36	PduRefP	73	<b>Application</b>	
Read	37	ChkFail	74	UncSvSnt	145
Timeout	38	Timeout	75	UncSvRcd	146
Regs	39	PduSent	76	CanSent	147
AnInput	40	PduRcvd	77	CanRcvd	148
AnOutput	41	ReTrans	78		
uCode	42	CrdtZero	79		
		OpenCon	80		



## Retrieve Log Events Request - 8102

The Retrieve Log Events request copies portions of the system Exception Log for the local station into a block of words specified in the request. This request provides access by the ladder program to the Log events.

The COMM\_REQ for the Retrieve Log Events Request is described below.

Table 7-6. Retrieve Log Events Request COMM\_REQ

Parameter Description	Word Offset	Value
Word Length of MDB	0	5
Wait/NoWait Flag	1	0 (No Wait)
CRSW Memory Type	2	See Table 5-2 <sup>1</sup>
CRSW Offset	3	
Idle Timeout Value	4	0
Maximum Communication Time	5	0
<b>Command Number</b>	6	8102 (1FA6H)
Data Buffer, Memory Type	7	See Table 6-42 <sup>1</sup>
Data Buffer, Offset	8	
Log Event Structure Offset	9	0-15
Log Event Length	10	0-16

<sup>1</sup> Quick Reference: Memory Type %R %AI %AQ %I %Q  
Decimal Value 8 10 12 70 72

**Command Number** - Identifies this as a Retrieve Log Events Request command.

**Data Buffer** - PLC address of where the log event data is to be put.

**Log Event Structure Offset** - The beginning offset into the system exception log to be retrieved. An offset of 0 marks the most recent event. The higher the offset, the older the event.

**Log Event Length** - The number of log events to be retrieved. Only complete events will be returned. It requires 176 words (352 bytes) to hold the entire system exception log.

The maximum number of events in the log is 16. If the log is full (16 recorded events) and a new event occurs, the oldest event is dropped. Each log event consists of 11 words worth of information. See Chapter 9 for the format and interpretation of the log events.

Table 7-7. Event Log Format

Word	Description
1	Date stamp low
2	Date stamp high
3	Time stamp low
4	Time stamp high
5	Count
6	Low byte is event code High byte is event modifier (Entry 1)
7-11	Log entry data (Entries 2-6)

## Restart Ethernet Interface Request - 8103

The COMM\_REQ for the Restart Ethernet Interface Request is described below.

**Table 7-8. Restart Ethernet Interface Request COMM\_REQ**

Parameter Description	Word Offset	Value
Word Length of MDB	0	1
Wait/NoWaitFlag	1	0 (No Wait)
CRSW Memory Type	2	See Table 5-2 <sup>1</sup>
CRSW Offset	3	
Idle Timeout Value	4	0
MaximumCommunicationTime	5	0
<b>CommandNumber</b>	6	8103 (1FA7H)

<sup>1</sup> Quick Reference:   Memory Type   %R   %AI   %AQ   %I   %Q  
                           Decimal Value   8   10   12   70   72

**Command Number** - Identifies this as a Restart Ethernet Interface Request command.

# Chapter 8

## *Tuning and Configuring Stations for an Advanced Network*

---

---

This chapter is designed for those who are configuring stations for an **advanced** network. Before using this chapter, you should be completely familiar with Chapter 3, The GENet System Manager--Station Configuration. The GSM is the tool used to configure all stations for both **basic** and **advanced** networks. Chapter 3 describes how to install and use the GSM and how to configure stations for a **basic** network.

### Definition of an *Advanced* Network

An **advanced** network is one in which one or more of the following conditions exist.

- Communications is between both 802.3 and 802.4 devices through a bridge,
- A router or gateway is used to interconnect networks,
- A host does not support the network layer ES-IS protocol,
- Large message sizes are used,
- Extreme high performance is demanded such as with multiple hosts communicating to a node simultaneously.

### Using this Chapter

This chapter contains all the screens in the GENet System Manager (GSM) Configuration Editors in addition to the Configure Network-Wide Parameters Screens. Make sure you have installed the GENet System Manager and know how to use it (see Chapter 3) before attempting to use the information in this chapter.

The chapter is divided into 3 sections.

- Section 1. Configuring GE Fanuc Series 90-70 Stations
- Section 2. Configuring LAN Communications with Foreign Devices
- Section 3. Configuring Network-Wide Parameters

## Configure a Station Screen

A number of different GE Fanuc Ethernet Interface products may be present on the LAN. Each GENet Ethernet Interface must be configured using that product's Configuration Editor before it can be downloaded. Before entering the Configuration Editor you must first access the *Configure a Station Screen* from the *GSM Main Menu*.

The Configure a Station Screen allows you to perform 3 main functions.

- Define a Station
- Select an Existing Station
- Delete a Station

The *Configure a Station Screen*, shown below, is used to specify the Station Type and to assign a logical name (STATION\_NAME) to the station. The STATION\_NAME corresponds to the unique MAC\_ADDRESS which physically identifies the station on the network. It is also used to modify certain configuration parameters for a station.

When the Edit configuration keys (Alt-E) are pressed in this menu, the GSM calls the Configuration Editor required for that specific Station Type of GENet Ethernet Interface.

Configuration parameters are stored in files on the PC hard disk and downloaded to the GENet Ethernet Interface using the GSM Downloader.

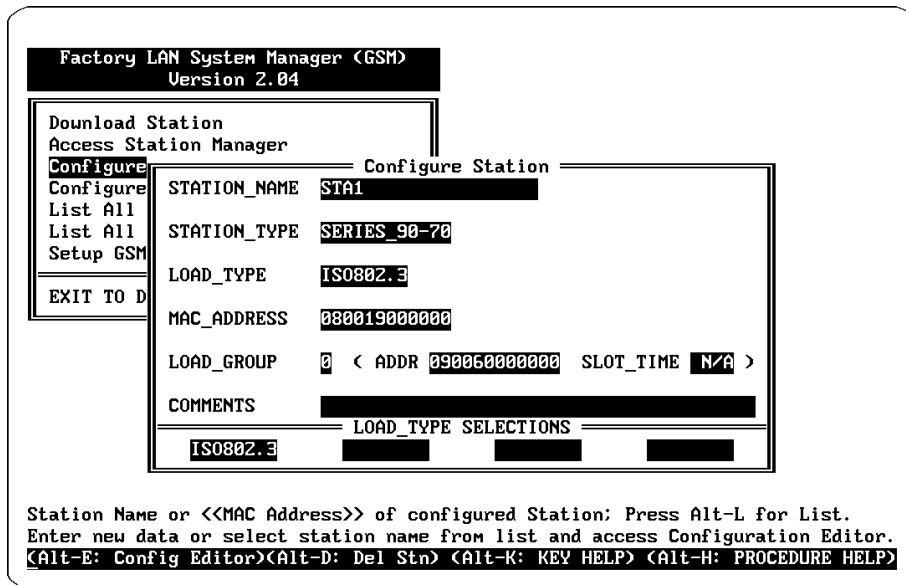

Figure 8-1. Configure a Station Screen

### Note

A form has been provided to assist you in recording configuration data. Refer to Appendix I. Forms.

## Defining a Station

1. Type in or select desired values for the STATION\_NAME, STATION\_TYPE fields, etc. See the description of screen fields below.
2. Press Alt-E to enter the Configuration Editor.

### Field Definitions for the Configure a Station Screen

STATION\_NAME - A name (1 to 20 characters) which is used to uniquely identify the station.

STATION\_TYPE - The type of device containing the Ethernet Interface.

- The value for this field is selected from a set of choices; press the Tab key to view the choices. The number of choices will vary depending on your installation.
- Possible values include: S\_15\_MA, S\_15\_TA, S\_15\_TT, S\_16\_MA, S\_16\_TA, SERIES\_90-70, FOREIGN\_DEV.
  - SERIES\_90-70 is used for the Series 90-70 PLC Ethernet Interfaces
  - S\_15\_MA , S\_15\_TA, S\_15\_TT are used for the Series 15 MA/TA/TTCNC OSI-Ethernet Interfaces.
  - S\_16\_MA and S\_16\_TA are used for the Series 16 MA/TA CNC OSI-Ethernet Interfaces.
  - FOREIGN\_DEV is used to identify non-GE Fanuc devices. It allows information about non-GE Fanuc devices to be entered into the Application DIBs.

LOAD\_TYPE - The type of station being configured. For Series 90-70 PLCs, this can be ISO802.3 or MAP 3.0.

MAC\_ADDRESS - The 12 hex digit MAC address of the station being configured. This will be either the Default MAC Address as delivered with your board, or a Locally Administered MAC Address in the case where you have specified the MAC address yourself. See the description on the structure of the MAC Address in Chapter 3.

Each LAN Interface is delivered with a Default Station Address already set. There are several ways to determine this value:

- Look on the label located on the LAN Interface
- Use the Station Manager NODE command.
- Press the Restart button to see the MAC address appear on the Station Manager terminal screen (be sure the Station Manager terminal is connected to the Interface).

The Default Station (MAC) Address is a globally administered address; the global administration process assures that each default MAC address is unique. Your organization may have its own scheme of how addresses are administered. In this case you will not use the default address, but will assign a different address from a set of numbers established by your address administrator.

LOAD\_GROUP - The number of the selected download group for the station. The Load Group selects which multicast address is used when loading the station. The multicast addresses and slot times are assigned to the Load Groups via the System Network Parameters menu. Value may be 0 to 4 (default is 0).

COMMENTS - This field is optional, but may be used to insert a comment line up to 40 characters long for the station being configured. These comments will be displayed on the List All Stations Screen.

## Selecting a Station

Select a station by filling in the STATION\_NAME field in one of three ways.

- Type in the Station Name, or
- Type in a << MAC Address>> specified as exactly 12 hexadecimal digits within a double set of brackets (for example, <<08001901001d>>). The GSM will convert the MAC address into the corresponding station name, or
- Select a station from a list of stations. Press Alt-L for the list. From this list, you select the desired station, which is then displayed on the *Configure a Station Menu*.

The Up Arrow, Down Arrow, Pg Up, Pg Dn, Home, and End keys may be used to move within the list. You may also begin a search by pressing Alt-S. When the desired station is displayed at the top of the list, press the Enter key to select that station. The selected station name is then displayed on the Configure a Station Screen.

After selecting a station, you may press Alt-E to enter the Configuration Editor.

## Deleting a Station

1. Select the station you want to delete. (See description above on Selecting a Station.)
2. Press Alt-D. The GSM will ask the operator to confirm deletion of the station and any configuration data saved for that station.

## Section 1: Configuring a Series 90-70 PLC Station

This sections describes all the screens used to configure parameters for Series 90-70 PLCs.

### Configuration Editor Main Menu for the Series 90-70 PLC

Once a station has been defined in the *Configure a Station Menu*, you may proceed to the *Configuration Editor Main Menu* (by pressing Alt-E) to define that station's communications parameters in more detail. Or, you can return to this menu at any time in the future to examine or modify these parameters. The screen below is the Configuration Editor for the STATION\_TYPE, SERIES\_90-70.

#### Note

GEnet System Manager releases prior to 2.04 and Configuration Editors prior to 3.22 have a different menu hierarchy. This manual reflects GSM changes first released in GSM 2.04 and Configuration Editor 3.22.

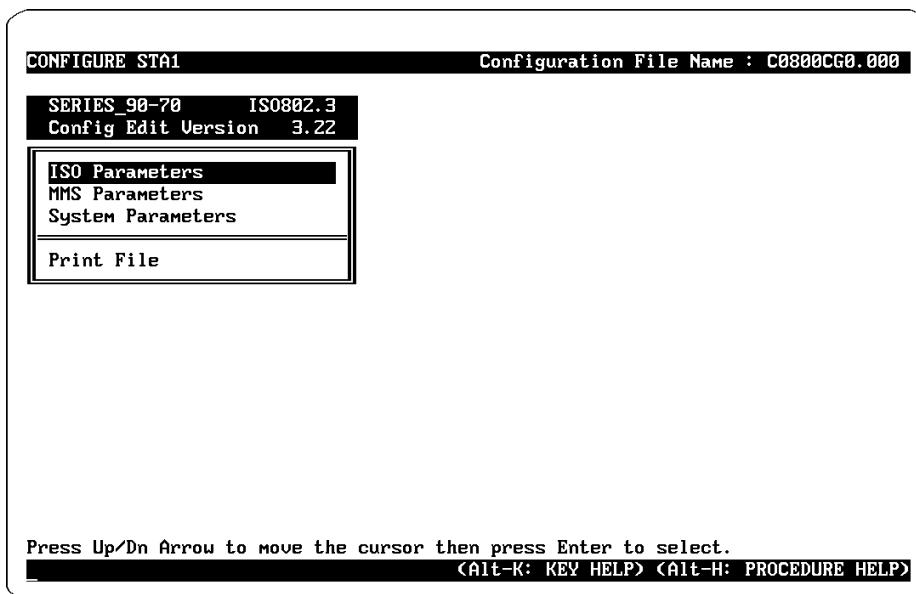

Figure 8-2. Configuration Editor Main Menu

From this menu, you can access the various sub-menus and screens that allow you to enter or modify parameters values. The parameters have been divided into three main categories: ISO, MMS, and System. Each of these categories may contain sub-categories with corresponding screens.

## Saving Changes Before Exiting the Configuration Editor Main Menu

The *Configuration Editor Main Menu* is the first displayed when entering the Configuration Editor and it is the last displayed before exiting the Configuration Editor.

Typically, after you have entered the Configuration Editor, you will go into sub-screens and enter or change values for the parameters included in them. After you have made changes in a sub-screen, you must press Alt-U to save them temporarily.

After you have finished making changes in the sub-screens and back out to the *Configuration Editor Main Menu*, you must press Alt-U again to save the changes to disk. If you press Esc to exit the *Configuration Editor Main Menu*, a prompt will appear to confirm the exit without saving.

## Menu Structure

The rest of this section is organized in the following fashion: First an overview of the main menu selections is given. This lists the sub-categories and types of parameters that are found within each category. Then each sub-menu and screen that can be reached from the main menu is discussed.

There are a number of menus that can be entered in order to configure the various communications parameters.

The ***ISO Parameters Menu*** selection is used to modify most of the communications parameters. This menu selection is used to examine and modify the parameters for the Network Layer, Network Layer RIB Table, Transport and Session Layer, Application Processes, Association, Abstract Syntaxes, and Local Application DIB (Directory Information Base).

The ***MMS Parameters Menu*** is used to modify the MMS parameters. This menu selection is used to examine and modify Variable Names, and Maximum MMS Message Size.

The ***System Parameters Menu*** is used to modify parameters which determine how the Ethernet Interface allocates its available buffer memory. This menu is also used to modify the Station Manager parameters.

Finally, the ***Print File Menu*** is used to name and create a DOS file which contains a copy of the Ethernet Interface's configuration.



## ISO Parameters Menu

The ISO Parameters Menu lists the communications parameters that may be changed. The ISO Parameters Menu is shown below:

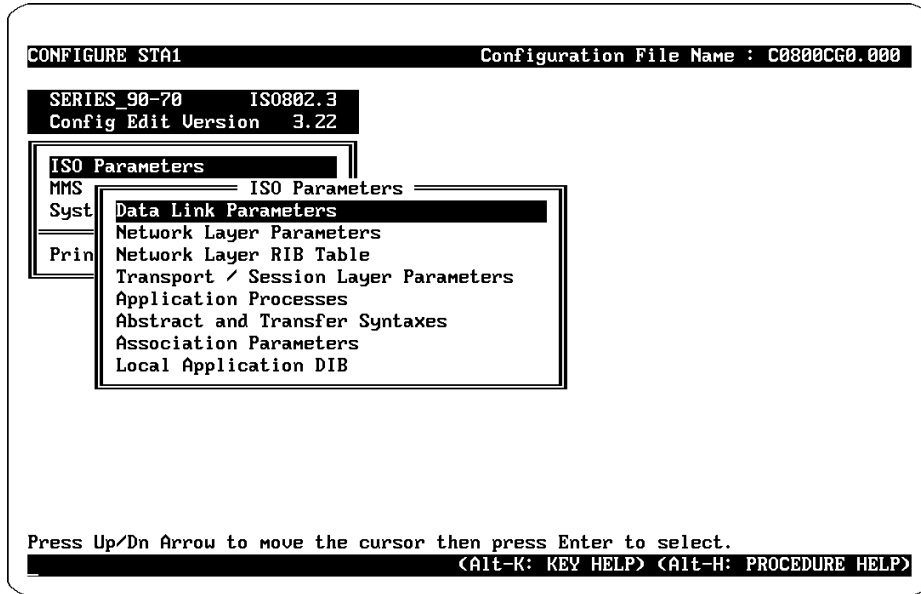

Figure 8-3. ISO Parameters Menu

Each sub-menu is discussed next in the order in which they appear on the ISO Parameters Menu.

## Data Link Parameters Screen

The Data Link Parameters Screen allows you to modify the Data Link Layer communication parameters. In most cases the values of these parameters will remain the default values. The Data Link Parameters menu is shown below.

```

CONFIGURE STA1                               Configuration File Name : C0800CG0.000
SERIES_90-70   IS0802.3
Config Edit Version  3.22

ISO Param  Data Link Parameters
MMS        TX_RING_LEN * 8                    RX_RING_LEN 32
Syst       MAX_DATA_BUF 1497                 DISAB_TX_RTRY N
Prin
Dat
Net
Net
Tra
App
Abs
Ass
Loc

ENTRY  ADDRESS
0      09002B000004  HEX
1      090019000001  HEX
2      000000000000  HEX
3      000000000000  HEX
4      000000000000  HEX
5      000000000000  HEX
6      000000000000  HEX
7      000000000000  HEX

Transmitter Ring Length (8, 16, 32, 64, 128) Default 8
Edit parameters on screen and press Alt-U to update them.
(Alt-U: Update Parameters)      (Alt-K: KEY HELP) (Alt-H: PROCEDURE HELP)

```

Figure 8-4. Data Link Parameters Screen

The Data Link Parameters are defined as follows:

**TX\_RING\_LEN** - The maximum number of frames which can be queued for transmission on the network. Valid values are 8, 16, 32, 64, and 128 frames. Defaults to 8 frames. Value selected by Tab or Shift-Tab keys. Corresponds to Station Manager Parameter *ltxringlen*.

**RX\_RING\_LEN** - The maximum number of incoming frames received by this station which can be queued for processing. Valid values are 8, 16, 32, 64, and 128 frames. Defaults to 8 frames. Value selected by Tab or Shift-Tab keys. Corresponds to Station Manager Parameter *lrxringlen*.

**MAX\_DATA\_BUF** - The maximum data size of Link Layer receive buffers. This the largest possible receive frame for the Link Layer. Valid range of 128 to 8192 octets. Defaults to 1497 octets. Should be at least 70 less than the Maximum Buffer Size (see the System Parameters Menu on page 3-94). Corresponds to Station Manager Parameter *lmaxdb*.

**DISAB\_TX\_RTRY** - Prevents the normal automatic TX retries when a frame collision occurs during transmission. Valid values are "Y" and "N". "Y" specifies that TX retries are disabled. "N" specifies that each TX frame will be retried up to 16 times. Defaults to "N". Corresponds to Station Manager Parameter *ldrtry*.

Up to 8 Receive data Group Addresses may be programmed for frame reception. Multicast receive frames are accepted if they match one of these Group Addresses.

ADDRESS - One of 8 Group Addresses used for reception of multicast frames. A 6-octet hexadecimal octet string which represents a valid multicast address. Individual station addresses, or the broadcast address <<FFFFFFFFFFFF>> are not permitted. Entry 0 defaults to <<09002B000004>>, which is the All-ES MAC address. Entry 1 defaults to <<090019000001>>, which is the Group Address used when a Logic-master 90-70-Ethernet station is browsing for PLCs on the network. All other entries default to zero <<000000000000>> to indicate that the entry is not used. Corresponds to Station Manager Parameter *lgrpmsk0* - *lgrpmsk7*.

There are two ways to exit this screen and return to the ISO Parameters Menu:

- Esc key - exit without saving changes.
- Alt-Ukey - save changes and exit.

## Network Layer Parameters Screen

The Network Layer Parameters Screen selection is used to modify the Network Layer communications parameters. The Network Layer Parameters Screen is shown below:

```

CONFIGURE STA1                               Configuration File Name : C0800CG0.000
SERIES_90-70      IS0802.3
Config Edit Version 3.22

Network Layer Parameters
NSAP 4908001900000001 HEX      LSAP FE HEX
PACKET_PRIORITY 7      MAX_NPDU_SIZE 1497
NPDU_LIFETIME 10      CONFIG_TIME 30      HOLDING_TIME 75
QUERY_WAIT_TIME 45      CHECK_TIME 10      USE_CHECKSUMS N
OPTIMIZE N
ALL_END_SYSTEMS (ES) MAC_ADDRESS 09002B000004 HEX LSAP FE HEX
ALL_INTERMEDIATE_SYSTEMS (IS) MAC_ADDRESS 09002B000005 HEX LSAP FE HEX

Network Service Access Point for this node (hexadecimal)
Edit parameters on screen and press Alt-U to update them.
<Alt-U: Update Parameters>      <Alt-K: KEY HELP> <Alt-H: PROCEDURE HELP>

```

Figure 8-5. Network Layer Parameters Screen

### The Network Layer Parameters are defined as follows:

**NSAP** - The Network Service Access Point for this node. Entered as a hexadecimal string of octets. Defaults to 49<MAC\_Address>01. Corresponds to Station Manager Parameter *nsap*.

**LSAP** - The Link Service Access Point. Entered as a hexadecimal octet. Defaults to FE. Corresponds to Station Manager Parameter *alsap*.

**PACKET\_PRIORITY** - The Link Layer Priority at which the Network Layer data packets are sent on the LAN. Valid range of 0 to 7. Defaults to 7. Corresponds to Station Manager Parameter *npriority*.

**MAX\_NPDU\_SIZE** - The maximum Network Layer data packet size. Valid range of 256 to 8196 octets. Defaults to 1497 octets. Corresponds to Station Manager Parameter *nmaxpdu*.

**NPDU\_LIFETIME** - The lifetime, in one-half second intervals, of a NPDU being sent out onto the network by the local node. Valid range of 0 to 65535. Defaults to 5 seconds (10 one-half second intervals). Corresponds to Station Manager Parameter *npdulife*.

**CONFIG\_TIME** - The time interval (in seconds) between End-System Hello (ESH) NPDUs sent by this node. Valid range of 0 to 65535. Defaults to 30 seconds. Corresponds to Station Manager Parameter *ncfgtime*.

**HOLDING\_TIME** - The amount of time (in seconds) that a remote node should keep information contained in an ESH NPDU issued by the local node. Should be more

than twice the value of CONFIG\_TIME Valid range of 0 to 65535. Defaults to 75 seconds. Corresponds to Station Manager Parameter *nhltime*

QUERY\_WAIT\_TIME - The time interval (in seconds) the local node should wait for some remote node to provide a translation (from NSAP address to MAC address and LSAP) that was requested by the local node. Valid range of 0 to 65535. Defaults to 45 seconds. Corresponds to Station Manager Parameter *nqwttime*.

CHECK\_TIME - The number of seconds between checking the Routing Information Base (RIB) for expired entries and checking incoming segmented NPDUs for an NPDU whose lifetime expired in reassembly. Valid range of 0 to 65535. Defaults to 10 seconds. Corresponds to Station Manager Parameter *ntick*.

USE\_CHECKSUMS - Indicates whether or not checksums are to be used on NPDUs sent by the local node. A "Y" specifies that checksums are used, a "N" specifies that they are NOT used. Defaults to "N". Corresponds to Station Manager Parameter *nchksum*, where a "1" equates to "Y", and a "0" equates to "N".

OPTIMIZE - Indicates whether or not ISO 9542 optimization is to be used. This means that when a RIB entry for an Intermediate System (IS) expires and is removed, any additional entry in the RIB for that IS's network address will also be removed (if "Y" is specified). "Y" specifies that optimization is used, a "N" specifies that optimization is NOT used. Defaults to "N". Corresponds to Station Manager Parameter *noptimiz*, where a "1" equates to "Y", and a "0" equates to "N".

ALL\_END\_SYSTEMS (ES) MAC\_ADDRESS - The All End Systems (ES) MAC Address to be used by the Network Layer. Entered as a hexadecimal string of octets. Defaults to <<09002B000004>>. Corresponds to Station Manager Parameter *nesmac*.

ALL\_END\_SYSTEMS LSAP - The All End Systems (ES) Link Service Access Point to be used by the Network Layer. Entered as a hexadecimal octet. Defaults to FE. Corresponds to Station Manager Parameter *neslsap*.

ALL\_INTERMEDIATE\_SYSTEMS (IS) MAC\_ADDRESS - The All Intermediate Systems (IS) MAC address to be used by the Network Layer. Entered as a hexadecimal string of octets. Defaults to <<09002B000005>>. Corresponds to Station Manager Parameter *nismac*.

ALL\_INTERMEDIATE\_SYSTEMS LSAP - The All Intermediate Systems (IS) Link Service Access Point to be used by the Network Layer. Entered as a hexadecimal octet. Defaults to FE. Corresponds to Station Manager Parameter *nislslap*

There are two ways to exit this screen and return to the ISO Parameters Menu:

- Esc key - exit without saving any changes.
- Alt-U key - save changes and exit.

## Network Layer RIB Table Screen

The ISO Network Layer ES-IS protocol provides a means for each station on the network to dynamically inform others of its NSAP and sub-Network-layer addressing. There are some OSI implementations that do not dynamically provide this information. In the unlikely event that your GENet node must communicate with such stations, this menu will allow you to statically provide the equivalent information, thus allowing communications that otherwise would not be possible. For more information see the section, "Specifying Automatic or Static Routing", following the parameter definitions.

The table you create here is known as the Network Layer Routing Information Base (RIB) Table; it is shown below. You may create up to 10 static routing entries in the RIB table.

```

CONFIGURE STA1                               Configuration File Name : C0800CG0.000
SERIES 90-70      IS0802.3
Config Edit Version  3.22

ISO Parameters
MMS                ISO Parameters
Syst              Data Link Parameters
                  Network Layer Parameters
Prin              Network Layer RIB Table - ENTRY 0
                  DESTINATION_NSAP [REDACTED] HEX
                  FIRST_HOP_NSAP [REDACTED] HEX
                  FIRST_HOP_MAC_ADDR [REDACTED] HEX
                  FIRST_HOP_LSAP [FE] HEX

Destination Network Service Access Point (hexadecimal) Null for IS
Edit parameters on screen and press Alt-U to update, Pg Up/Dn to change entry #.
(Alt-U: Update Parameters)      (Alt-K: KEY HELP) (Alt-H: PROCEDURE HELP)

```

Figure 8-6. Network Layer RIB Table Screen

The Network Layer RIB Table parameters are defined as follows:

**DESTINATION\_NSAP** - The Network SAP of the End System with which you wish to communicate. Entered as a blank or an even-numbered string of hexadecimal digits.

**FIRST\_HOP\_NSAP** - The Network SAP of the first hop. The first hop is either the nearest Router or, if there is no Router, the end system with which you wish to communicate. See the section immediately below titled "Specifying Automatic or Static Routing." Entered as a blank or an even-numbered string of digits.

**FIRST\_HOP\_MAC\_ADDR** - The MAC Address of the first hop. Entered as a blank or as 12 hexadecimal digits.

**FIRST\_HOP\_LSAP** - The Link SAP of the first hop. Defaults to FE and cannot be changed.

## Specifying Automatic or Static Routing

1. To use ES-IS (automatic) routing, use the default settings (DESTINATION\_NSAP, FIRST\_HOP\_NSAP, and FIRST\_HOP\_MAC\_ADDR all blank).
2. Static (fixed) Routing is selected whenever FIRST\_HOP\_NSAP is not blank. To use Static Routing, set all fields as follows:
  - To access a *specific* End System that is on your *local* sub-network (i.e., a Router is not needed), set DESTINATION\_NSAP and FIRST\_HOP\_NSAP to the NSAP of that End System and FIRST\_HOP\_MAC\_ADDR to the MAC Address of that End System. In the figure below, an example is End System, "A", to End System, "B".
  - To access a *specific* End System on *another* sub-network via a Router, set DESTINATION\_NSAP to the NSAP of the End System and FIRST\_HOP\_NSAP and FIRST\_HOP\_MAC\_ADDR to the NSAP and MAC Address of the nearest Router. An example is End System, "B", to End System, "C".
  - To access *any* End System on *another* sub-network via a Router, leave DESTINATION\_NSAP blank and set FIRST\_HOP\_NSAP and FIRST\_HOP\_MAC\_ADDR to the NSAP and MAC Address of the nearest Router. An example is End System, "C", to both End Systems, "A" and "B".

There are two ways to exit this screen and return to the ISO Parameters Menu:

- Esc key - exit without saving any changes.
- Alt-U key - save changes and exit.

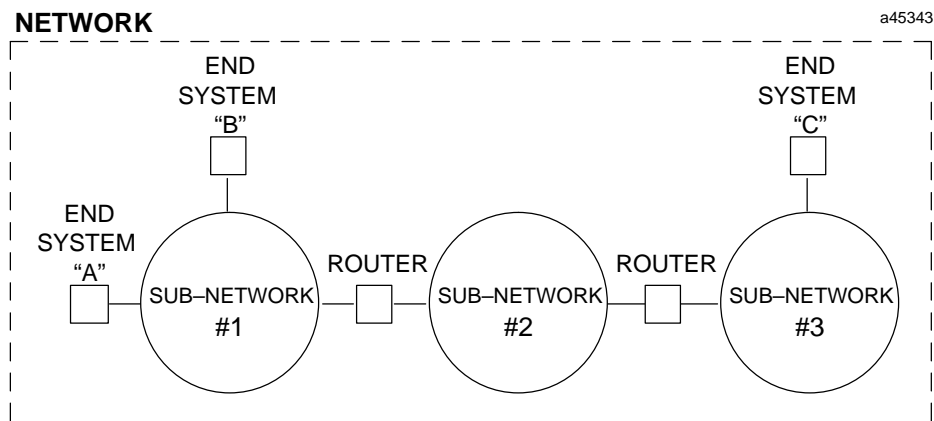

Figure 8-7. Specifying Automatic or Static Routing

## Transport / Session Layer Parameters Screen

The Transport / Session Layer Parameters Screen selection is used to modify the Transport and Session Layers communications parameters.

The Transport and Session Layer Parameters Screen is shown below:

```

CONFIGURE STA1 Configuration File Name : C0800CG0.000
SERIES_90-70 IS0802.3
Config Edit Version 3.22
ISO Parameters
MMS ISO Parameters
Transport / Session Layer Parameters
MAX_PDUSZ_LOG2 10 <1024 OCTETS> WINDOW_SIZE 2
REF_TIMEOUT 0 RETRAN_COUNT 5 GIVEUP_TIMEOUT 15
INACTIVE_TIMEOUT 60 RETRAN_TIMEOUT 15 WINDOW_TIMEOUT 25
USE_CHECKSUM N ACK_DELAY_TIME 0 SESSION_TIMEOUT 25
TSAP 0001 HEX
Maximum Transport PDU size in log2 <? - 12> Default 10
Edit parameters on screen and press Alt-U to update them.
<Alt-U: Update Parameters> <Alt-K: KEY HELP> <Alt-H: PROCEDURE HELP>

```

Figure 8-8. Transport/Session Layer Parameters Screen

### Transport Layer: The Transport Layer parameter definitions are:

**MAX\_PDUSZ\_LOG2** - The Maximum Transport Layer PDU Size negotiated for data transfers. Specified as a power of 2 to get the actual size ( a value of 10 implies  $2^{10}$  or a size of 1024 octets). Valid range of 7 to 12. Defaults to 10. Corresponds to Station Manager Parameter *tmaxpdu*.

**WINDOW\_SIZE** - The Maximum Window Size, or Credit Allocation, allowed for the receipt of Data Transfer (DT) TPDUs. Valid range of 1 to 5. Defaults to 2. Corresponds to Station Manager Parameter *twindsize*.

**REF\_TIMEOUT** - Establishes the period during which a source reference cannot be reassigned to another Transport connection. Valid range 0 to 300 seconds. Defaults to 0 seconds. Corresponds to Station Manager Parameter *treftime*.

**RETRAN\_COUNT** - Establishes the maximum number of re-transmissions for Connect Request (CR), Connect Confirm (CC), Data Transfer (DT), Expedited Data (ED), and Disconnect Request (DR) TPDUs. Valid range of 1 to 10. Defaults to 5. Corresponds to Station Manager Parameter *trtrancnt*.

**GIVEUP\_TIMEOUT** - Give Up Timeout for the Transport Layer. This timer is started when a TPDU has been retransmitted the maximum number of times. If it times out before an acknowledgement is received for the TPDU, the Transport connection is broken. Valid range of 0 to 300 seconds. Defaults to 15 seconds. Corresponds to Station Manager Parameter *tgiveup*.



**INACTIVE\_TIMEOUT** - Establishes the maximum time that the Transport connection will be maintained without receiving a TPDU. Valid range of 0 to 300 seconds. Defaults to 60 seconds. Corresponds to Station Manager Parameter *tinactive*.

**RETRAN\_TIMEOUT** - Retransmission Timeout for the Transport Layer. When it expires, it causes re-transmission of unacknowledged Connect Request (CR), Connect Confirm (CC), Data Transfer (DT), Expedited Data (ED), and Disconnect Request (DR) TPDU's. Valid range of 0 to 300 seconds. Defaults to 15 seconds. Corresponds to Station Manager Parameter *trtrantime*.

**WINDOW\_TIMEOUT** - Window Timeout for the Transport Layer. When this timeout expires, an Acknowledge (AK) TPDU is transmitted. Should be less than the value for the Transport Layer inactivity timer (INACTIVE\_TIMEOUT). Valid range of 0 to 300 seconds. Defaults to 25 seconds. Corresponds to Station Manager Parameter *twindow*.

**USE\_CHECKSUM** - Determines whether or not the Transport checksums are negotiated during Transport connection establishment. A "Y" specifies that checksums are used, a "N" specifies that they are NOT used. Defaults to "N". Value toggled by the Tab or Shift-Tab keys. Corresponds to Station Manager Parameter *tchksum*, where a "1" equates to "Y", and a "0" equates to "N".

**ACK\_DELAY\_TIME** - Acknowledge Delay Timeout for the Transport Layer. Valid range of 0 to 300 seconds. Defaults to 0 seconds. Corresponds to Station Manager Parameter *tlcack*.

### **Session Layer: The Session Layer parameters are defined as follows:**

**SESSION\_TIMEOUT** - Session Timeout for the Session Layer. This timer establishes the maximum interval to wait before disconnecting the Transport connection. It allows time for a connection-ending Session PDU to reach its destination. Valid range of 0 to 300 seconds. Defaults to 25 seconds. Corresponds to Station Manager Parameter *stime*.

**TSAP** - The ISO Transport Service Access Point to be used for communications services. Entered as a string of hexadecimal octets. Defaults to 0001 (hex). Corresponds to Station Manager Parameter *stsap*.

There are two ways to exit this screen and return to the ISO Parameters Menu:

- Esc key - exit without saving any changes.
- Alt-U key - save changes and exit.

## Application Processes Screen

The Application Processes Screen selection is used to examine and modify the names of the Ethernet Interface Application Processes. The different communication services are accessed by establishing an association with the appropriate Ethernet Interface Application Process.

The Application Processes screen is shown below:

```

CONFIGURE STA1 Configuration File Name : C0800CG0.000
SERIES_90-70 IS0802.3
Config Edit Version 3.22
Application Processes
>MMS_RESPONDER
COMMON_NAME RESP080019000000
APT_OBJ_ID {
AE_QUAL 0 PSAP 00000001 HEX SSAP 0001 HEX
>APPLICATION_INTERFACE
COMMON_NAME APPL080019000000
APT_OBJ_ID {
AE_QUAL 0 PSAP 00000002 HEX SSAP 0001 HEX
>MMS
ACN ISO MMS
ACN_OBJ_ID { 1 0 9506 2 3 }
>ALTERNATE_MMS
ACN ISO MMS1
ACN_OBJ_ID {
Application Common Name (1 - 64 characters)
Edit parameters on screen and press Alt-U to update them.
(Alt-U: Update Parameters) (Alt-K: KEY HELP) (Alt-H: PROCEDURE HELP)

```

Figure 8-9. Application Processes Screen

### The Application Processes parameters are defined as follows:

For MMS\_Responder and Application Interface processes, six parameters may be defined; these parameters are described below. For MMS and Alternate MMS processes, only the ACN\_OBJ\_ID parameter may be modified.

**COMMON\_NAME** - The Common Name of the Application Process. Each Common Name MUST be unique on the entire network. Consists of 1 to 64 characters.

- For MMS RESPONDER - defaults to "RESP" + MAC\_ADDRESS. For MMS RESPONDER - corresponds to Station Manager Parameter *arespcnam*.
- For APPLICATION\_INTERFACE - defaults to "APPL" + MAC\_ADDRESS. For APPLICATION\_INTERFACE - corresponds to Station Manager Parameter *applcnam*.

**APT\_OBJ\_ID** - The Application Process Title (APT) Object Identifier. Defaults to blank. Optional and may be left blank. Defined as an object identifier. Consists of a sequence of numeric values.

- For MMS RESPONDER - corresponds to Station Manager Parameter *arespapt*.
- For APPLICATION\_INTERFACE - corresponds to Station Manager Parameter *applapt*.

AE\_QUAL - The Application Entity (AE) Qualifier of the Application Process. Defaults to 0. A decimal number ranging from 0 to 65535.

- For MMS RESPONDER - corresponds to Station Manager Parameter *arespaequal*
- For APPLICATION\_INTERFACE - corresponds to Station Manager Parameter *applaequal*

PSAP - The Presentation Service Access Point (PSAP) of the Application Process. Each PSAP within a given station must be unique. Entered as a string of hexadecimal octets.

- For MMS RESPONDER - defaults to 01 (hexadecimal). For MMS RESPONDER - corresponds to Station Manager Parameter *aresppsap*.
- For APPLICATION\_INTERFACE - defaults to 02 (hexadecimal). For APPLICATION\_INTERFACE - corresponds to Station Manager Parameter *applpsap*.

SSAP - The Session Service Access Point (SSAP) of the Application Process. Each SSAP within a given station must be unique. Entered as a string of hexadecimal octets.

- For MMS RESPONDER - defaults to 01 (hexadecimal). For MMS RESPONDER - corresponds to Station Manager Parameter *arespsap*.
- For APPLICATION\_INTERFACE - defaults to 02 (hexadecimal). For APPLICATION\_INTERFACE - corresponds to Station Manager Parameter *applssap*.

ACN - The Application Context Name of the Application Process.

- For MMS - corresponds to Station Manager Parameter *mmsacn*.
- For ALTERNATE\_MMS - corresponds to Station Manager Parameter *maltacn*.

ACN\_OBJ\_ID - The Application Context Name (ACN) Object Identifier of the Application Process. Defined as an object identifier. A sequence of numeric values. For MMS - defaults to {1 0 9506 2 3}.

- For MMS - corresponds to Station Manager Parameter *mmsacnobj*
- For ALTERNATE\_MMS - corresponds to Station Manager Parameter *maltacnobj*

There are two ways to exit this screen and return to the ISO Parameters Menu:

- Esc key - exit without saving any changes.
- Alt-Ukey - save changes and exit.

## Abstract and Transfer Syntaxes Screen

This screen selection is used to modify the Abstract and Transfer Syntax definitions. The Abstract Syntaxes Screen is shown below:

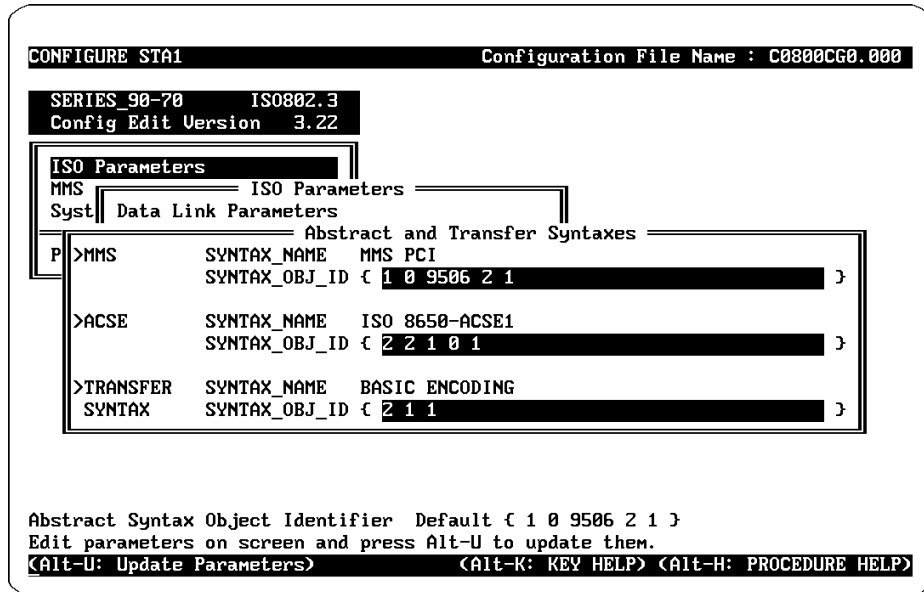

Figure 8-10. Abstract and Transfer Syntaxes Screen

The Abstract and Transfer Syntax parameters are defined as follows:

SYNTAX\_OBJ\_ID - The Object Identifier of the Abstract Syntax. Defined as an object identifier. A sequence of numeric values.

There are two ways to exit this screen and return to the ISO Parameters Menu.

- Esc key - exit without saving any changes.
- Alt-U key - save changes and exit.

## Association Parameters Screen

The Association Parameters Screen selection is used to specify the maximum number of associations that each Application Process can have established at one time.

The Association Parameters Screen is shown below:

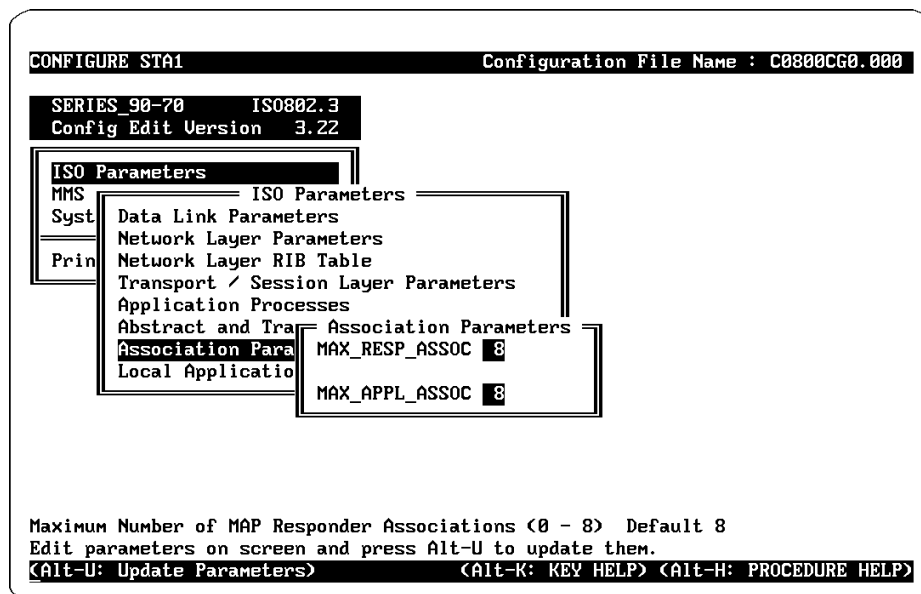

Figure 8-11. Association Parameters Screen

The Association Parameters limit the number of associations which a particular Application Process may have at a given time. This is useful to insure that resources are available to the other communication services when needed. The Ethernet Interface will support a TOTAL of 8 simultaneous Associations (including any SRTP associations, such as Logicmaster 90 operating over Ethernet.

### The Association Parameters are defined as follows:

**MAX\_RESP\_ASSOC** - The maximum number of simultaneous Responder associations that may exist at one time. Valid range of 0 to 8. Defaults to 8. Corresponds to Station Manager Parameter *assocresp*.

**MAX\_APPL\_ASSOC** - The maximum number of simultaneous Application Interface associations that may exist at one time. Valid range of 0 to 8. Defaults to 8. Corresponds to Station Manager Parameter *assocappl*.

There are two ways to exit this screen and return to the ISO Parameters Menu.

- Esc key - exit without saving any changes.
- Alt-U key - save changes and exit.

## Local Application DIB Screen

The Local Application DIB (Directory Information Base) Screen is used to select Application Processes for inclusion in the Local Application DIB.

The Local Application DIB Screen is shown below:

```

CONFIGURE STA1 Configuration File Name : C0800CG0.000
----- Local Application DIB -----
> SELECTED Common Name
           Station Name                               Station Type
-----
> N      RESP080019000000
           STA1                                       SERIES_90-70
> N      APPL080019000000
           STA1                                       SERIES_90-70
> N      RESP080019000001
           STA2                                       SERIES_90-70
> N      APPL080019000001
           STA2                                       SERIES_90-70
> N      RESP080019000003
           STA3                                       SERIES_90-70
> N      APPL080019000003
           STA3                                       SERIES_90-70
>
           [ END-OF-LIST ]
----- 0 out of a maximum of 10 entries selected -----
Application Selected. (Y/N) Default N. Press Tab to change selection and update.
Cursor/Page/Search through list and view Application Process details.
<Alt-U: Update Params> <Alt-U: View> <Alt-K: KEY HELP> <Alt-H: PROCEDURE HELP>

```

Figure 8-12. Local Application DIB Screen

This screen has the same basic format as the GENet System Manager 7-Layer Application DIB screen. Information is placed into the 7-Layer Application DIB when an Application Process (Common Name) is defined when configuring a station. The Local Application DIB Screen displays a list of all 7-Layer Application DIB entries that have been defined. The Local Application DIB may be examined using the Up Arrow, Down Arrow, PgUp, PgDn, Home, and End keys.

SELECTED - specifies whether that 7-Layer Application DIB entry has been selected for inclusion in the Local Application DIB. Valid values are "Y" and "N". Defaults to "N". Value toggled by the Tab and Shift-Tab keys

The details about a specific DIB entry can be examined by pressing the Alt-V key. When the Alt-V key is pressed, the operator is prompted for which DIB entry to examine. If no COMMON\_NAME is entered, the top entry in the list is displayed.

The Alt-S key is used to search the DIB for a specific entry. When the Alt-S key is pressed, the user selects the data field and a value to seek and selects the search direction. The Alt-S key is pressed again to initiate the search, or the Esc key is pressed to abort the search.

There are two ways to exit this screen and return to the ISO Parameters Menu.

- Esc key - exit without saving any changes.
- Alt-U key - save changes and exit.

## MMS Parameters Menu

The MMS Parameters Menu selection is used to modify the MMS parameters. The MMS Parameters Menu is shown below:

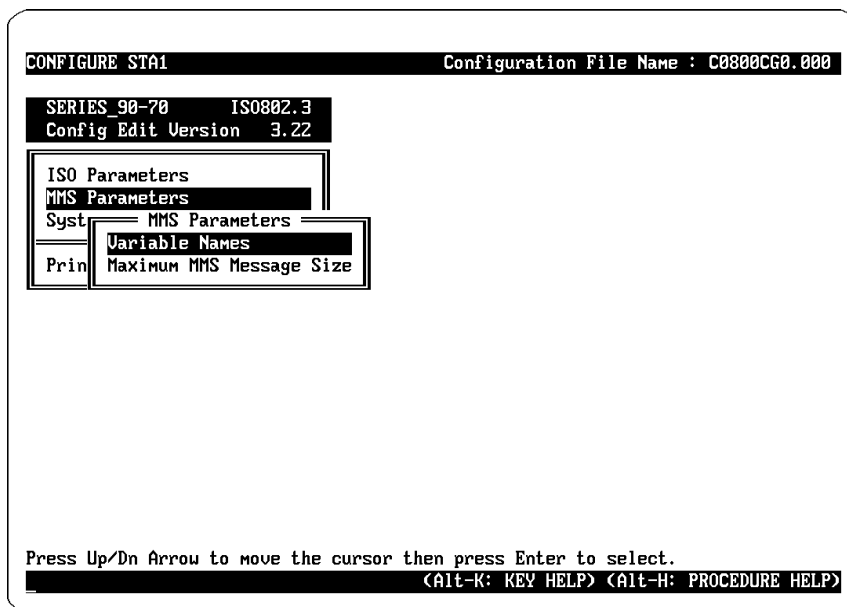

Figure 8-13. MMS Parameters Menu

This menu selection is used to examine and modify:

- Variable Names
- Maximum MMS Message Size

The sub-menus are described below.

## Variable Names Screen

The Variable Names Screen selection is used to modify the Variable Name Table used by the MMS-Ethernet Interface. In order to make applications simpler, data in the Series 90-70 PLC can be accessed through a symbolic name, called a Variable Name. The names defined in this menu are in the Virtual Manufacturing Device (VMD) Specific scope of MMS. This means that the names are available without regard to what program is executing in the Series 90-70 PLC.

The Variable Names Screen is shown below:

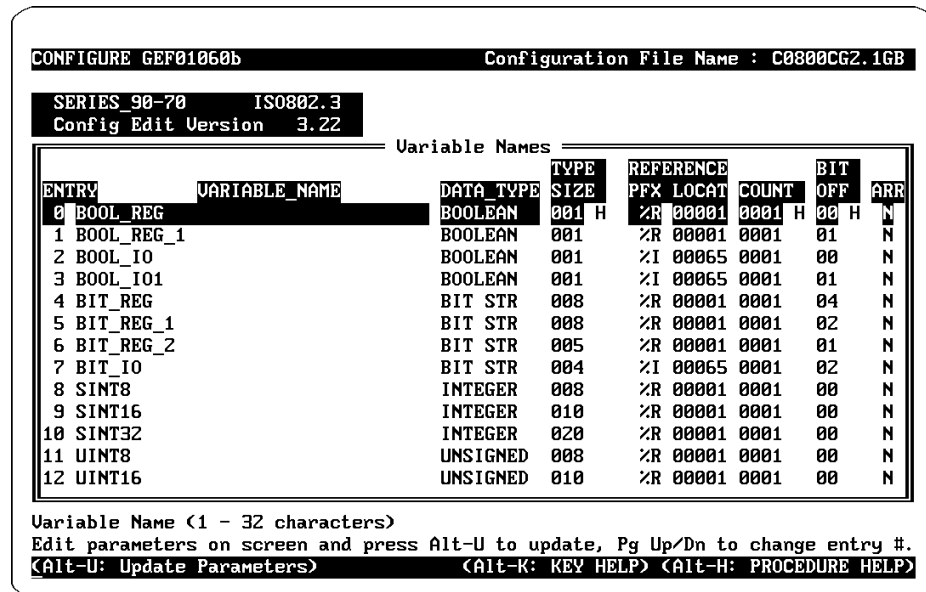

Figure 8-14. Variable Names Screen

The PgUp and PgDn keys are used to scroll through the Variable Name entries.

### The Variable Names Parameters are defined as follows:

**ENTRY** - Each entry contains a variable which defines a specific range of addresses in Series 90-70 PLC memory. Remote applications can then access specific memory locations by referencing these variable names in Read or Write requests. The Variable Name table holds up to 64 variables.

**VARIABLE\_NAME** - The defined variable name. Consists of 1 to 32 characters.

**DATA\_TYPE** - The type of data specified by the variable name. Tab and Shift-Tab keys scroll between the choices. Value is one of:

- Character string (CHAR STR)
- Octet string (OCTET STR)
- Floating point (FLOAT PT)
- Unsigned integer (UNSIGNED)
- Integer (INTEGER)



- Bit string (BIT STR)
- Boolean (BOOLEAN)

TYPE SIZE - The number of octets or bits in the data type. Valid range of 1 to 800 (hexadecimal). Entered as a hexadecimal number.

- For OCTET STR or CHAR STR, TYPE SIZE specifies the number of OCTETS in the variable or variable array element
- For BIT STR, BOOLEAN, UNSIGNED, or INTEGER, the TYPE SIZE specifies the number of BITS in the variable or in the variable array element
- For FLOAT PT only the value 4 should be used

REFERENCE - The memory reference within the Series 90-70 PLC. Table 6-15 shows the possible values for the reference address.

COUNT - The number of variable array elements. Entered as a hexadecimal number. Valid range 1 to FFFF (hexadecimal). For variables which are not arrays (i.e. scalars), this field should be set to 1.

BIT OFF - The bit offset relative to the starting address of this variable. Entered as a hexadecimal number. Valid range of 00 to 0F (hexadecimal). Used only if the Data Type specifies a BIT STR or BOOLEAN data type; for all other data types, it must be 00.

ARR - Specifies if the variable is an array or a scalar variable. Valid values of "Y" or "N". "Y" specifies that the variable is an array, "N" specifies that the variable is a scalar. Defaults to "N". Value toggled by the Tab or Shift-Tab keys.

There are two ways to exit this screen and return to the MMS Parameters Menu:

- Esc key - exit without saving changes.
- Alt-U key - save changes and exit.

## Maximum MMS Message Size Screen

The Maximum MMS Message Size Screen is used to display the Maximum MMS Message Size parameter.

The Maximum MMS Memory Size Screen is shown below:

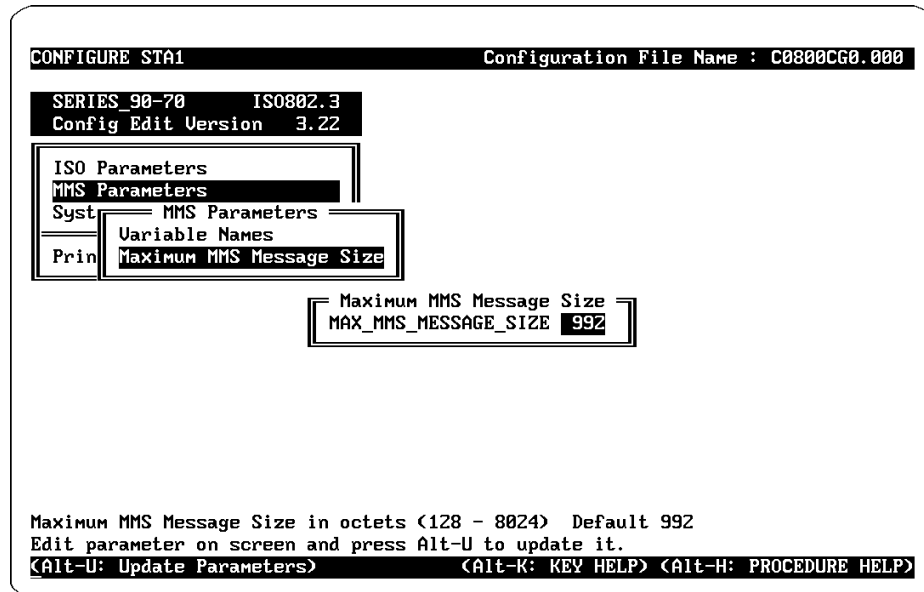

Figure 8-15. Maximum MMS Message Size Screen

The Maximum MMS Message Size Parameter is defined as follows:

**MAX\_MMS\_MESSAGE\_SIZE** - The maximum length of a MMS message that can be sent or received. Determines the maximum message size which is negotiated between two application processes. Valid range from 128 to 8192 octets. Defaults to 992 octets. Corresponds to Station Manager Parameter *mmaxmsgsz*. Should be at least 150 less than the Maximum Buffer Size.

There are two ways to exit this screen and return to the MMS Parameters menu:

- Esc key - exit without saving changes.
- Alt-U key - save changes and exit.

## System Parameters Screen

The System Parameters Screen selection is used to modify parameters which determine how the Ethernet Interface allocates its available buffer memory. This screen is also used to modify Station Manager parameters.

The System Parameters Screen is shown below:

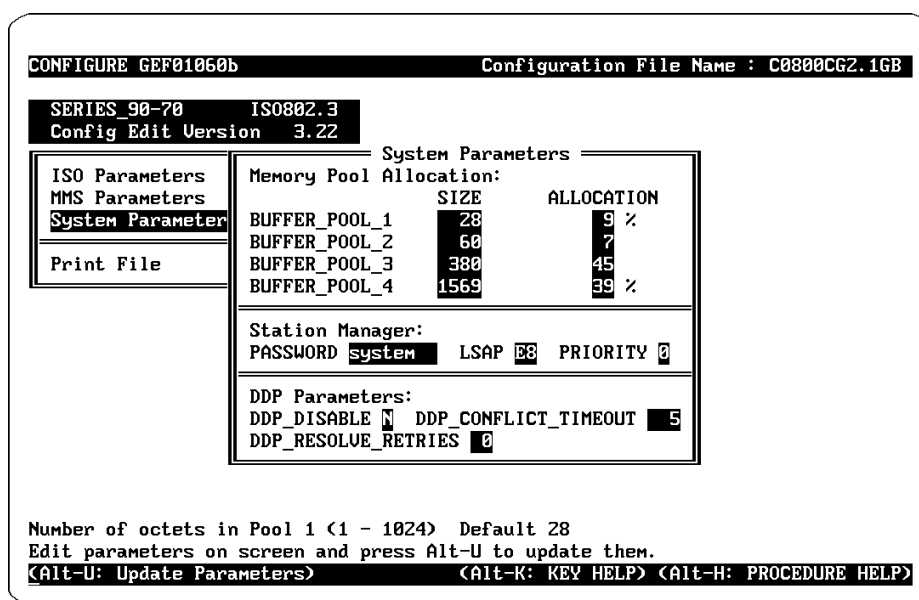

Figure 8-16. System Parameters Screen

### Memory Pool Allocation Parameters

The Memory Pool Allocation fields define the buffer pools used by the Ethernet Interface. The Ethernet Interface RAM memory available after all the Ethernet Interface executive software and configuration information has been loaded is broken into four fixed-size pools.

The MEMORY ALLOCATION parameter specifies the percentage of available memory to be allocated to each pool. For example, a value of 10 in this field would assign 10 percent of available memory to be allocated to this pool. The total of the MEMORY ALLOCATION for all buffer pools cannot exceed 100 percent. If the total is less than 100 percent, some of the available memory will not be used.

Buffers are used to hold messages which are sent or received on the network and to save state information regarding the communications software. IN ALL CASES, there must be buffers available and of sufficient size to contain the messages sent or received. This means that the size of the largest buffer pool must exceed such parameters as the Maximum MMS Message Size, the Maximum TPDU Size, or the Maximum LLC Data Buffer Size, by a margin sufficient to allow for protocol header overhead.

The Buffer Size of the Buffer Pools must be specified in increasing order as follows:

$$\text{Buffer Size Pool 1} < \text{Buffer Size Pool2} < \text{Buffer Size Pool3} < \text{Buffer Size Pool 4}$$

**The ranges for the Buffer Pool Parameter values are:****BUFFER\_POOL\_1** - Buffer Pool 1 memory allocation

**BUFFER SIZE** - Valid range of 1 to 1024 octets. Defaults to 28. Corresponds to Station Manager Parameter *bbuff1*.

**MEMORY ALLOCATION** - Valid range of 1 to 97 percent. Defaults to 9 percent. Corresponds to Station Manager Parameter *balloc1*.

**BUFFER\_POOL\_2** - Buffer Pool 2 memory allocation

**BUFFER SIZE** - Valid range of 1 to 2048 octets. Defaults to 60. Corresponds to Station Manager Parameter *bbuff2*.

**MEMORY ALLOCATION** - Valid range of 1 to 97 percent. Defaults to 7 percent. Corresponds to Station Manager Parameter *balloc2*.

**BUFFER\_POOL\_3** - Buffer Pool 3 memory allocation

**BUFFER SIZE** - Valid range of 1 to 4096 octets. Defaults to 380. Corresponds to Station Manager Parameter *bbuff3*.

**MEMORY ALLOCATION** - Valid range of 1 to 97 percent. Defaults to 45 percent. Corresponds to Station Manager Parameter *balloc3*.

**BUFFER\_POOL\_4** - Buffer Pool 4 memory allocation

**BUFFER SIZE** - Valid range of 540 to 8192 octets. Defaults to 1569. Corresponds to Station Manager Parameter *bbuff4*.

**MEMORY ALLOCATION** - Valid range of 1 to 97 percent. Defaults to 39 percent. Corresponds to Station Manager Parameter *balloc4*.

**The Station Manager Parameters are as follows:**

**PASSWORD** - The password that is used to modify the secure mode of the Station Manager. Case sensitive. Consists of up to 8 characters. Defaults to "system" (lower case).

**LSAP** - The Station Manager Link Service Access Point (LSAP) to be used to send and receive Station Manager REMote commands and responses. Defaults to E8 (hexadecimal). Corresponds to Station Manager Parameter *bremlsap*.

**PRIORITY** - The Link Layer priority used to send Station Manager REMote commands and responses. Valid range of 0 to 7. Defaults to 0. Corresponds to Station Manager Parameter *brempri*.

---

**The Distributed Directory Protocol Parameters are as follows:**

**DDP\_DISABLE** - This parameter permits disabling of the Distributed Directory Protocol (DDP). Default is "N". DDP must not be disabled (DDP-Disable must be "N") to use Logicmaster 90-70-Ethernet with this station. Corresponds to Station Manager parameter *vdpcisab*.

**DDP\_CONFLICT\_TIMEOUT** - Specifies maximum timeout to detect a duplicate name assignment. Units are 100 ms. Valid range is 1 to 600. Default is 5 (500 ms). Corresponds to Station Manager parameter *vdptmout*.

**DDP\_RESOLVE\_RETRIES** - Reserved for future use. Default to 0. Corresponds to Station Manager parameter *vdpretry*.

There are two ways to exit this screen and return to the Configuration Editor main menu:

- Esc key - exit without saving changes.
- Alt-U key - save changes and exit.

## Print File Screen

The Print File Screen selection is used to create a file which contains a copy of the Ethernet Interface's configuration. The file created can be printed to produce a hard copy of the configuration.

The Create Print File Screen is shown below:

```

CONFIGURE STA1                               Configuration File Name : C0800CG0.000
SERIES_90-70   IS0802.3
Config Edit Version  3.22
ISO Parameters
MMS Parameters
System Parameters
Print File

Create Print File
PRINT_FILE_NAME P0800CG0.000

Name of file to store print data   Default: Pxxxxxx.xxx in config directory
Edit parameter on screen and press Alt-P to create print file.
(Alt-P: Create Print File)        (Alt-K: KEY HELP) (Alt-H: PROCEDURE HELP)

```

Figure 8-17. Print File Screen

The Print File Screen Parameter is defined as follows:

**PRINT\_FILE\_NAME** - the name of the file to be created. Consists of 1 to 14 characters. Defaults to Pxxxxxxx.xxx where xxxxxxxx.xxx is an ASCII encoding of the station's 48-bit MAC address. The location of the print file defaults to the C:\GSM\CFILES directory. May reference another disk drive, (for example, A:WC47.LIS).

There are two ways to exit this screen and return to the Configuration Editor Main Menu:

- Esc key - exit without creating a file.
- Alt-P key - causes the print file to be created and stored on the disk, then exits.

## Section 2: Configuring Network-Wide Parameters

This section describes configuration of the Load Group and 802.4 parameters.

### Configure Network-Wide Parameters Menu

The Network-Wide Parameters Menu is used to examine and modify the download multicast address and slot time parameters for each Load Group. As each station is configured it is assigned to one of these load groups.

The Network-Wide Parameters Menu is shown below.

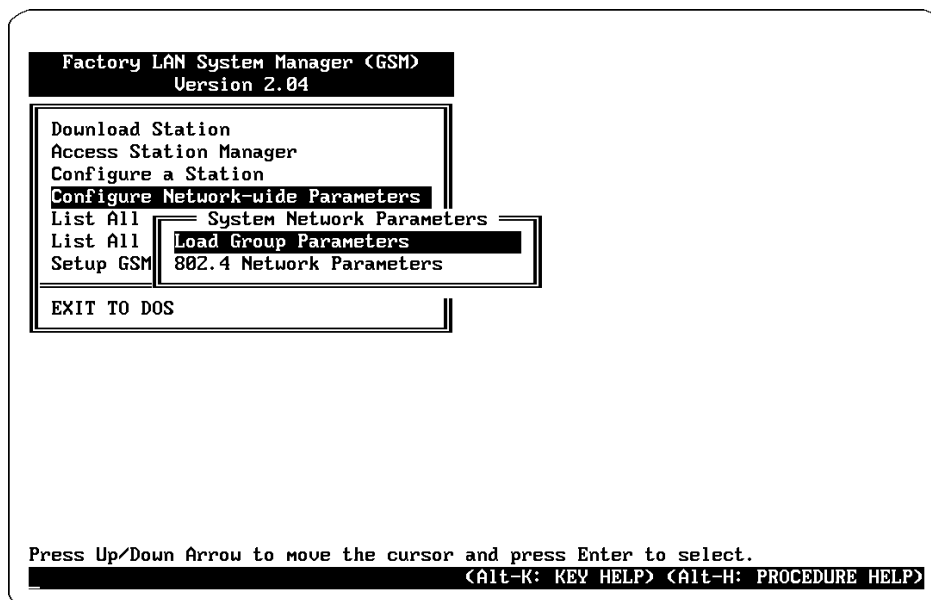

Figure 8-18. Configure Network-Wide Parameters Menu

#### Note

The 802.4 Network Parameters Screen is not used by the Ethernet Interfaces. It is used only by 802.4 MAP Interfaces, which share the GSM configurator.

# Load Group Parameters Screen

The Load Group Parameters Screen is shown below.

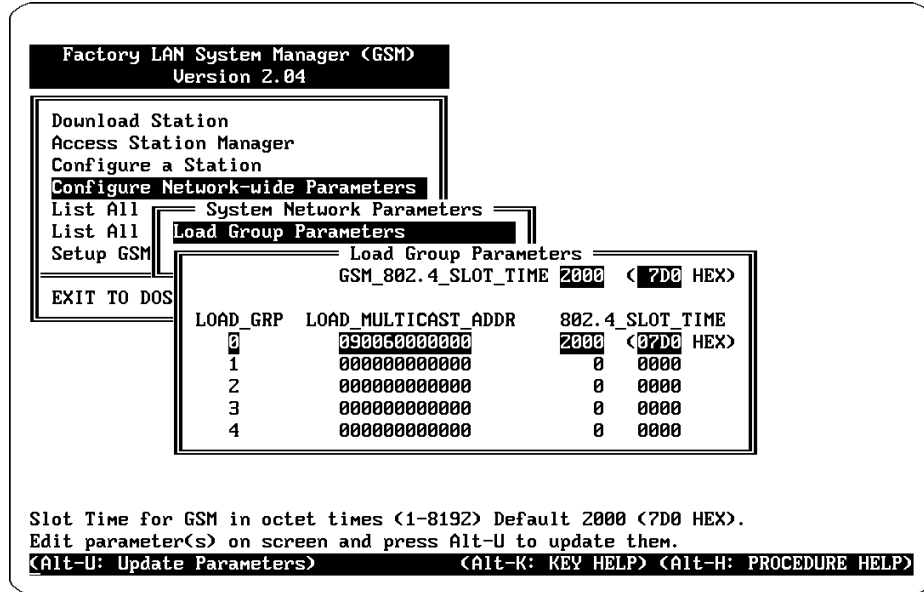

Figure 8-19. Load Group Parameters Screen

The Load Group Parameters are defined as follows:

The following parameter may be entered for each of the five Load Groups:

LOAD\_MULTICAST\_ADDR - Not used by local GSM. The value for Load Group 0 defaults to 090060000000 (hexadecimal)

### Note

The Slot Time data on this screen is not used by the Ethernet Interfaces. It is used only by 802.4 MAP Interfaces, which share the GSM configurator.



# Chapter 9

## Troubleshooting

---

---

This chapter is a guide to troubleshooting and problem isolation for the Series 90-70 Ethernet Interfaces.

This chapter includes the sections listed below:

- Overview
- Using this Chapter
- What to do if you Cannot Solve the Problem
- The Power-Up State
- The Soft Switch Entry State
- The Field Network Test State
- The Loader State
- The Operational State
  - Troubleshooting When the STATUS OK LED is OFF
  - Troubleshooting When the STATUS OK LED is ON
  - Log Event Error Codes
  - Extended Status Buffer Errors
- GEnet LAN Interface Status Word (LISW)

### Overview

There are several tools to assist you in diagnosing problems with the Series 90-70 Ethernet Interface and the network.

- The Ethernet Interface LEDs provide an immediate visual summary of the operational state of the Ethernet Interface.
- The COMM\_REQ Status Word, LAN Interface Status Word, and Association Control Block are used within the PLC ladder program to view the LAN Interface status.
- The Ethernet Interface Station Manager Exception Log, Extended Status Buffer, and TALLY command provide detailed information about the Ethernet Interface via a GEnet System Manager (GSM) or terminal.

- The Series 90-70 PLC Fault Table provides a record of exceptions logged by the PLC, the Ethernet Interface, and other Series 90-70 modules. The PLC Fault Table may be accessed through the Logicmaster 90-70 Configurator or Programmer software. Refer to the *Series 90-70 Programmable Controller Reference Manual* for more information.

Also, when displaying a PLC Fault Table entry on the Logicmaster 90-70, striking <CTRL -F> will display an additional line of numeric data on the Message Line (third line from the top). For GENet Ethernet Interfaces the leftmost 16 digits of the long string of digits on the right half of the Message Line show the corresponding GENet log Events and Entries 2, 3, and 4 (in that order). This information can be used to refer directly to detailed fault descriptions in this chapter (Table 9-10) without using a GSM.

For detailed information about these tools, refer to the appropriate references in the table below.

**Table 9-1. Ethernet Interface Diagnostic Tools**

<b>Diagnostic Tool</b>	<b>Description</b>	<b>Reference</b>
LEDs	Visual observation of Ethernet Interface	Chapters 2, 9
COMM_REQ Status Word	Access from PLC ladder program	Chapter 5
LAN Interface Status Word	Access from PLC ladder program	Chapter 5
Association Control Block	Access from PLC ladder program	Chapter 6
Log	Access from Station Manager	Chapters 4, 9
Log	Access from PLC ladder program	Chapter 7
Extended Status Buffer	Access from Station Manager	Chapter 4
Extended Status Buffer	Access from PLC ladder program	Chapter 7
Tallies	Access from Station Manager	Chapter 4
Tallies	Access from PLC ladder program	Chapter 7
PLC Fault Table	Ethernet Interface exceptions logged with CPU	Chapter 9 Also GFK-0265

## Using this Chapter

This chapter contains five troubleshooting sections that correspond to the five main states of the Ethernet Interface.

If you have a problem, first identify in which state the problem occurred. Then, go to the corresponding section in this chapter for further information.

The following tables are included to assist you in troubleshooting.

- LED Display Codes - Tables 9-2 through 9-6.
- Troubleshooting with ONLINE LED OFF - Tables 9-7.
- Troubleshooting with ONLINE LED ON - Table 9-8.
- Log Events Codes - Tables 9-9 and 9-10.
- Extended Status Buffer Codes - Tables 9-11 and 9-12.

The following information indicates the state of the Ethernet Interface:

1. **Power-Up State** - The board is executing power-up diagnostics.

- The MODULE OK LED is BLINKING fast or OFF.
- The ONLINE LED is OFF.
- The STATUS OK LED is BLINKING or OFF.

In the power-up state, the Station Manager and the Restart pushbutton are inoperative.

2. **Soft Switch Entry State** - Soft Switch configuration may be (in some cases must be) entered via the Logicmaster 90-70 Configurator or the Ethernet Interface local Station Manager (when the Ethernet Interface is not configured in the CPU).

- The MODULE OK LED is BLINKING slowly.
- The ONLINE LED is OFF.
- The STATUS OK LED is OFF.

A NODE command at the Station Manager will indicate “Soft Switch Entry Utility”. The Station Manager prompt in this case is an asterisk (“\*”).

3. **Field Network Test State** - Test frames may be exchanged with other nodes on the network, using a factory-set configuration.

- The MODULE OK LED is ON.
- The ONLINE LED may be ON, OFF, or BLINKING.
- The STATUS OK LED may be ON or OFF.

A NODE command at the Station Manager will indicate “Field Network Test Utility”. The Station Manager prompt in this case is a dollar sign (“\$”).

4. **Loader State** - The communications software must be loaded or is being loaded.

- The MODULE OK LED is ON.
- The ONLINE LED may be ON, OFF, or BLINKING.
- The STATUS OK LED is BLINKING.

A NODE command at the Station Manager will indicate “Software Load Utility”. There is no Station Manager prompt while in the loader. If the Ethernet Interface is looking for a download from the serial port, repeated “ipl” messages will be displayed at the Station Manager terminal.

5. **Operational State** - The communications software has been loaded, and is running.

- The MODULE OK LED is ON.
- The ONLINE LED may be ON, OFF, or BLINKING.
- The STATUS OK LED may be ON or OFF.

A NODE command at the Station Manager will identify the node without indicating any of the other “special” states. The default Station Manager prompt in this case is a greater-than sign (“>”).

The figure below shows the control flow upon restarting the Ethernet Interface. This flow determines the state of the Interface.

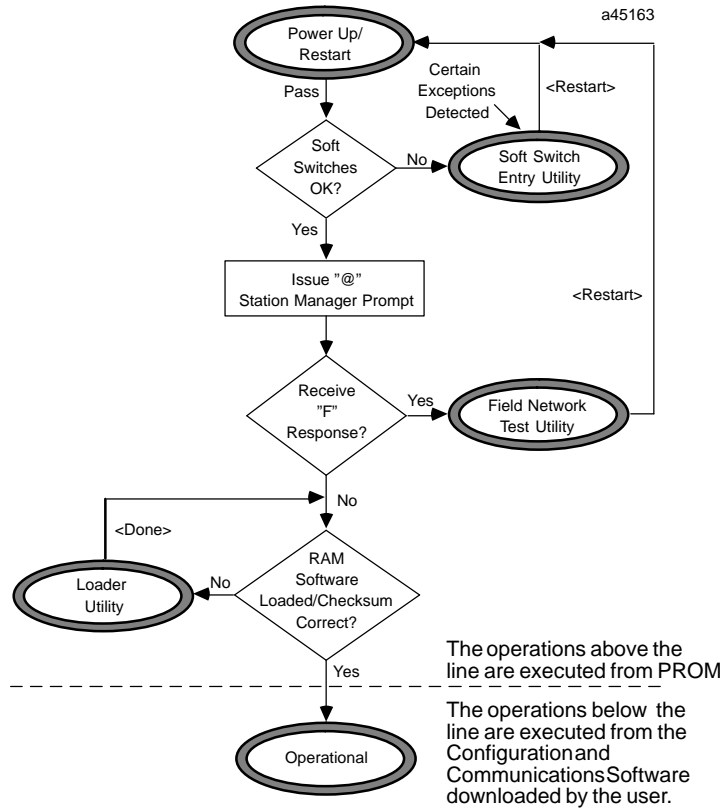

Figure 9-1. Determining the State of the Ethernet Interface

## What to do if you Cannot Solve the Problem

If, after using the troubleshooting guide, you still cannot solve your problem, call GE Fanuc Automation. Please have the following information available when you call.

- The Name and Catalog Number marked on the product (on hinged door in front of controller board).
- The PROM version (printed in the output from the NODE command).
- The Software version (printed in the output from the NODE command).
- Description of symptoms of problem. *Depending on the problem -- you may also be asked for the following information:*
  - The ladder logic application program running at the time the problem occurred.
  - A listing of the configuration parameters for the station that failed.
  - A description of the network configuration (number of stations, length of trunk cable, number of taps or transceivers, and the manufacturer and model of all devices connected to the network at the time of failure).

## The Power-up State

When power is cycled on the Series 90-70 PLC, or whenever the Ethernet Interface is restarted, power-up diagnostics run. Diagnostics running is indicated by the MODULE OK LED blinking fast, while the other LEDs remain OFF. If the Ethernet Interface detects an error in the hardware, it reports this error to the CPU, then shuts down. All LEDs turn OFF if the Ethernet Interface fails a diagnostic test. If this happens, refer to the PLC Fault Table for detailed information.

### Note

The Restart/Load Pushbutton is not operable during the Ethernet Interface diagnostic phase nor is the Station Manager active. The Ethernet Interface is in diagnostic phase when the MODULE OK LED is BLINKING and the ONLINE and STATUS OK LEDs remain OFF.

After diagnostics complete, both the MODULE OK LED and STATUS OK LED blink slowly for 2-3 seconds. (The ON LINE LED is OFF during this time.) This LED sequence identifies the time you may enter the Field Network Test State by entering an “F” or “f” at the Station Manager terminal. The table below shows the LED patterns for the power-up diagnostics phase.

Table 9-2. Power-Up State

LED	Running Diagnostics (15/30 sec)*	Wait for Field Network Test (2-3 sec)	Wait for PLC & CPU Handshake (to 60 sec)	Diagnostic Failed
MODULE OK	Blink	Slow Blink	Slow Blink	OFF
ONLINE	OFF	OFF	OFF	OFF
STATUS OK	OFF	Slow Blink	OFF	OFF

\* 15 seconds for Ethernet Interface, 30 seconds for MAP Interface.

The PLC Fault Table can be especially helpful in detailing faults that are detected in the Power-Up State. In the Power-Up State, the Station Manager is not operational. The Ethernet Interface has likely failed and is far less able to report such failures in detail. See GFK-0265, *Logicmaster 90 Programming Software Reference Manual* for information on the PLC Fault Table.

### Note

If all LEDs go out after completing power-up diagnostics, then power-up diagnostics has failed. Refer to the PLC fault table for more information.

## The Soft Switch Entry State

The Soft Switch Entry State is indicated by the MODULE OK LED blinking slowly (every 2 seconds) while the other LEDs remain OFF. The Soft Switch Entry state is automatically entered when the Soft Switch data in the Ethernet Interface is invalid and has not been set up by the Logicmaster 90-70 Configurator. The Soft Switch Entry state is also entered when certain configuration faults that preclude full operation are detected. A limited subset of Station Manager commands is provided in this state. Refer to Chapter 4, “Soft Switch Entry Utility”, for further description of the Soft Switch entry state.

The operator must correct the fault forcing entry into this state before the Ethernet Interface may proceed. In most cases this may be done by using the Logicmaster 90-70 Configurator or the Station Manager *CHSOSW* command. It cannot be performed remotely from the network. After entering new Soft Switch information or correcting another fault, the Ethernet Interface must be restarted to begin using these new values.

In the Soft Switch Entry State, a NODE command to the Station Manager will yield a "Soft Switch Entry Utility" message following the station identification information; also, the Station Manager prompt is an asterisk ("\*").

**Table 9-3. Soft Switch Entry State**

LED	Soft Switch Entry State
MODULE OK	Slow Blink
ONLINE	OFF
STATUS OK	OFF

Slow Blink = Blink ON every 2 seconds.

## The Field Network Test State

The Field Network Test state is selected by entering a "F" or "f" in response to the "@" prompt at the local Station Manager terminal at the end of power-up diagnostics. The "f" will not be echoed back. A limited subset of Station Manager commands is provided in this state. Refer to Chapter 4, "Field Network Test Utility" for a detailed description of the Field Network Test state and to Chapter 2, "Installation Procedure 5 - Testing the Interfaces on the Network" for an application. The table below shows the LED patterns for Field Network Test State.

In the Field Network Test State, a NODE command to the Station Manager will indicate "Field Network Test Utility". The Station Manager prompt is a dollar sign ("\$").

**Table 9-4. Field Network Test State**

LED	Connected to LAN		Not Connected to LAN	
	Operating w/o Exceptions	An Exception has Occurred	Since Last Restarted	After Being Connected
MODULE OK	ON	ON	ON	ON
ONLINE	ON/Blink	ON/Blink	OFF	OFF
STATUS OK	ON	OFF <sup>2</sup>	ON	OFF <sup>2</sup>

Slow Blink = Blink ON every 2 seconds.

Fast Blink = Blink every 0.5 seconds.

1. ONLINE blinking indicates this node is sending or receiving data
2. When MODULE OK is ON and STATUS OK is OFF, it is necessary to use the Station Manager NODE, LOG, and SOSW commands to distinguish among the possible causes.

## The Loader State

The Loader State is indicated by the MODULE OK LED ON and the STATUS OK LED blinking. The ONLINE LED may go on and off while the Ethernet Interface waits for a download to start. The table below shows the LED patterns for the Loader State and describes the expected progression of the LEDs.

In the Loader State, when the Ethernet Interface is requesting a local (serial) download, a series of “ipl, ipl, ipl, ...” messages will be output to the local serial port. When the Ethernet Interface is requesting a network download, a NODE command will indicate “Software Load Utility”. There is no prompt character at the local Station Manager terminal in this state.

**Table 9-5. Loader State**

LED	Ethernet Interface is Looking for Load:			Ethernet Interface is Receiving Load:	
	Local Load	Network Load		Over Network	Local Serial Port
		GSM Downloader not on Network	GSM Downloader on Network		
MODULE OK	ON	ON	ON	ON	ON
ONLINE	OFF	OFF	ON	Fast Blink	OFF
STATUS OK	Slow Blink	Slow Blink	Slow Blink	Fast Blink	Fast Blink

Slow Blink = Blink ON every 2 seconds

Fast Blink = Blink ON every 1 second

## The Operational State

The Operational State is the state of normal operation of the Ethernet Interface. This section identifies the possible symptoms of problems which may occur while the module is operating.

During normal operation of the Ethernet Interface, the MODULE OK LED is ON. The other two LEDs (ONLINE, STATUS OK) provide information about the health of the Ethernet Interface and activity on the LAN. The table below shows the LED patterns you might see and their possible meanings.

In the Operational State, no “Utility” message follows the station ID in the NODE command. The prompt character at the local Station Manager terminal is a greater-than symbol (“>”), or, if you have “logged in” to the MODIFY level of access, “=”.

Table 9-6. Operational State

LED	Connected to LAN		Not Connected to LAN	
	Operating w/o Exceptions	An Exception has Occurred	Since Last Restarted	After Being Connected
MODULE OK	ON	ON	ON	ON
ONLINE	ON/Blink	ON/Blink	OFF	OFF
STATUS OK	ON	OFF <sup>2</sup>	ON	OFF <sup>2</sup>

Slow Blink = Blink ON every 2 seconds, Fast Blink = Blink ON every 1 second

1. ONLINE blinking indicates this node is sending or receiving data
2. When MODULE OK is ON and STATUS OK is OFF, it is necessary to use the Station Manager NODE, LOG, and SOSW commands to distinguish among the possible causes

## Troubleshooting When STATUS OK LED is OFF

If the Ethernet Interface is in the Operational State and the STATUS OK LED is OFF and the MODULE OK LED is ON, then the Ethernet Interface has detected an exception condition and has made an entry in the Exception Log. Each new (not repeating) log event is also sent to the PLC Fault Table, where it can be viewed using LogiMaster 90-70 Software.

The format of a log event as displayed by the Station Manager is shown below:

```

Date          Time          Event    Count  1      2      3      Entry
dd-mmm-yyyy  hh:mm:ss.s  xx      xxxx  xx   xxxx  xxxx  4      5      6

```

**Date** - The Date column contains the system date of the last occurrence of the logged event.

**Time** - The Time column contains the system time of the last occurrence of the logged event.

**Event** - The Event column gives the kind of event which occurred. Table 9-10 lists the possible values for events.



**Count** - The Count column contains a repetition count for the event. If events which are identical occur regularly, they might otherwise flood the log with useless entries. Instead of recording each repeated event in detail, the log simply keeps the time of the latest event and a count of the number of repetitions of the repeated event. Log entries are retained on restart and reloads of the Ethernet Interface.

**Entry** - The Entry columns contain detailed information about the event and is subdivided into 6 entries, Entry 1 - Entry 6.

## Troubleshooting When the STATUS OK LED is ON

Sometimes problems can occur even when the STATUS OK LED is ON, indicating normal operation. In this case, follow the troubleshooting procedure below.

**Table 9-7. Troubleshooting with ONLINE LED OFF**

LED Indicators	Possible Cause and Resolution
The ONLINE LED is OFF	<p>This indicates that an attempt to send a frame resulted in a local fault indication. This usually results from a hardware problem. If this occurs follow the procedure below.</p> <ul style="list-style-type: none"> <li>- Check to be sure the LAN ONLINE Soft Switch is set to "YES". By issuing the Soft Switch Station Manager command checking the Network Online field.</li> <li>- Check to be sure the drop cable is securely fastened to the controller board connector and to the transceiver.</li> <li>- Make sure the transceiver is securely fastened to the Ethernet network trunk cable.</li> <li>- Issue a TALLY L Station Manager. If either the <i>MacErr</i> or the <i>SQEErr</i> tally is non-zero, the local station may be experiencing an unstable network. In this case follow the procedure below.</li> </ul> <p>If this station is the only one experiencing problems:</p> <ul style="list-style-type: none"> <li>- Verify that the SQE jumper is enabled on the transceiver connected to the Ethernet Interface.</li> <li>- Re-tighten all transceiver cable connections.</li> <li>- Make sure the slide lock on the Ethernet Controller board is locked.</li> <li>- Replace the transceiver cable with a known good cable.</li> <li>- Verify that the Series 90-70 PLC power supply is properly grounded.</li> <li>- Make sure that the Ethernet Controller board ground safety wire is securely fastened.</li> <li>- Replace the transceiver with a known good transceiver.</li> </ul> <p>If all stations are experiencing the problem, the cable plant is probably at fault.</p> <ul style="list-style-type: none"> <li>- Recertify the cable plant.</li> </ul> <p>If the problem still exists, call GE Fanuc Automation for support.</p>

Table 9-8. Troubleshooting with ONLINE LED ON

LED Indicators	Possible Cause and Resolution
The ONLINE LED is ON, but there is no network activity.	<p>There are several possible causes if a station cannot transfer data on the network. These causes are described below with the appropriate action to be taken.</p> <ul style="list-style-type: none"> <li>- Ensure that the Series 90-70 PLC power supply is properly grounded.</li> </ul> <p><b>PLC Access Problem</b></p> <p>To verify that the Ethernet Interface can access the PLC, issue successive TALLY C Station Manager commands. If the <i>PlcSweep</i> tally is not increasing, there are no windows being provided by the PLC.</p> <ul style="list-style-type: none"> <li>- If any of the tallies <i>PlcAbt</i>, <i>MyAbt</i>, or <i>Timeout</i> are incrementing, there may be a hardware problem with the Series 90-70 PLC backplane interface. Check the PLC Fault Table for entries for the Ethernet Interface.</li> <li>- Make sure to set the Soft Switch parameter <i>bponline</i> to "YES".</li> <li>- Replace the digital controller board with a known good board.</li> </ul> <p><b>Possible Application Error</b></p> <p>To verify that the application requests are being seen and to determine how they are being processed, enter the EXS Station Manager command to look at the Extended Status Buffer.</p> <p>If no commands show up for any of the communication services and there are no log entries of event "a" and no evidence of problems accessing the PLC, call GE Fanuc Automation for support.</p> <p>If the Extended Status Buffer shows commands being issued, look at the error code in the Extended Status Buffer. If this value is not zero, it indicates that the requests are receiving a "COMM_REQ Complete With Error" status. Use Table 9-12 to determine the type of error and correct the error by changing the request. If after this, errors are still being returned, call GE Fanuc for support.</p>

## Exception Log Event Error Codes

The error codes below appear in the Event column of a log event. To view the log, issue the LOG command from the Station Manager.

Table 9-9. Exception Log Event Definitions

Log Event	Cause
1	Powerup. A log entry of this event will appear every time the Ethernet Interface is Restarted or powered up.
2	System events.
3	Network Layer events.
4	Transport Layer events.
5	Session Layer events.
6	Presentation Layer events.
7	Application Layer events.
8	PLC driver events.
9	SRTP Service Agent events.
a	COMM_REQ MDB events.
b	MMS Service Agent events.
c	LLC events.
e	MMS Provider events.
10	Directory User Agent events

**Table 9-10. Exception Log Event Codes**

Log Event Code	Possible Cause and Resolution															
Event "1" Powerup	<p>This is an event logged on every initialization of the Ethernet Interface. This event is meant to indicate the boundaries between Restarts. By checking the count for this event, you may find how many Restarts are occurring. This event never causes the STATUS LED to go OFF.</p> <p><b>Entry 2</b> indicates the type of system initialization, as described below:</p> <ul style="list-style-type: none"> <li>0 Normal Ethernet Interface startup (operational state).</li> <li>1 Soft Switch Entry Utility.</li> <li>2 Factory Network Test Utility.</li> <li>3 Field Network Test Utility. Field Network Test has been explicitly requested.</li> <li>4 Software Load Utility selected.</li> </ul> <p><b>Entry 3</b> indicates the event that caused the system initialization to occur:</p> <ul style="list-style-type: none"> <li>0 Normal powerup.</li> <li>1 Restart request through pushbutton.</li> <li>2 Load request through pushbutton.</li> <li>3 Station Manager restart request.</li> <li>4 Station Manager load request.</li> <li>5 Automatic restart due to system error (see preceding log event 2).</li> <li>6 Automatic load due to system error (see preceding log event 2).</li> <li>7 Entry from loader.</li> </ul> <p><b>Entry 4</b> shows the state of Soft Switches that may limit the extent of operation of the Ethernet Interface.</p> <table style="margin-left: auto; margin-right: auto;"> <thead> <tr> <th style="text-align: center;">Entry 4</th> <th style="text-align: center;">LAN Online</th> <th style="text-align: center;">BPOnline</th> </tr> </thead> <tbody> <tr> <td style="text-align: center;">0</td> <td style="text-align: center;">YES</td> <td style="text-align: center;">YES</td> </tr> <tr> <td style="text-align: center;">1</td> <td style="text-align: center;">YES</td> <td style="text-align: center;">NO</td> </tr> <tr> <td style="text-align: center;">2</td> <td style="text-align: center;">NO</td> <td style="text-align: center;">YES</td> </tr> <tr> <td style="text-align: center;">3</td> <td style="text-align: center;">NO</td> <td style="text-align: center;">NO</td> </tr> </tbody> </table>	Entry 4	LAN Online	BPOnline	0	YES	YES	1	YES	NO	2	NO	YES	3	NO	NO
Entry 4	LAN Online	BPOnline														
0	YES	YES														
1	YES	NO														
2	NO	YES														
3	NO	NO														
Event "2" System events	<p>This event is logged by the system when a catastrophic system error occurs. Check for the value of the system error in <b>Entry 2</b> of the log event and follow the instructions below.</p> <p>System Error: 01</p> <p>This error indicates that incorrect software has been loaded into the Ethernet Interface. <b>Entry 3</b> indicates the lowest required RAM software version; <b>Entry 4</b> indicates the actual RAM software version. The system cannot initialize with incorrect software. Check that the proper Ethernet Interface software is being downloaded by the GSM. If the Ethernet Interface PROM firmware has been recently upgraded, be sure that compatible software is being downloaded. This fault causes entry into the Soft Switch Entry Utility.</p>															

Table 9-10. Exception Log Event Codes - Continued

Log Event Code	Possible Cause and Resolution
Event "2" System events (Continued)	<p>System Error: 02 This error indicates that the loaded Ethernet Interface software requires a higher revision of the PROM firmware than is installed on the Ethernet Interface. <b>Entry 3</b> indicates the lowest required PROM firmware version; <b>Entry 4</b> indicates the actual installed PROM firmware version. <b>Entry 5</b> indicates the actual loaded RAM software version. The system cannot initialize with incorrect firmware. Check that the proper PROM firmware is installed. If the Ethernet Interface software has been recently upgraded, be sure that compatible PROM firmware is installed in the Ethernet Interface. This fault causes entry into the Soft Switch Entry Utility.</p> <p>System Error: 03 This error indicates that an outdated configuration data file has been loaded into the Ethernet Interface along with the software. <b>Entry 3</b> indicates the lowest required configuration data file version for the software; <b>Entry 4</b> indicates the actual loaded configuration data version. Check that the proper configuration data file is being downloaded by the GSM. If the Ethernet Interface software, or the GSM itself, has been recently upgraded, it may be necessary to update the configuration data file for this station. This fault causes entry into the Soft Switch Entry Utility.</p> <p>System Error: 04 This error indicates that an improper configuration file has been loaded for this station. The MAC address within the configuration file does not match the MAC address supplied by the Soft Switches. The system cannot initialize with an improper configuration file. Check that the proper MAC address is set in the Soft Switches. Also check that the station is configured with the proper MAC address in the GSM, and that the proper configuration file is being downloaded by the GSM. <b>Entries 3, 4, and 5</b> indicate the 12-digit MAC address obtained from the configuration file. The MAC address obtained from Soft Switches may be displayed with the NODE and SOSW Station Manager commands. This fault causes entry into the Soft Switch Entry Utility.</p> <p>System Error: 08 Soft Switch values are not defined. This fault causes entry to the Soft Switch Entry Utility. <b>Entry 3</b> distinguishes the reason for reporting Soft Switches not defined: 0 CLSOSWStation Manager command was issued. 1 EEPROM checksum was incorrect.</p> <p>System Error: 09 Unable to set the Ethernet Interface date and time to the same values as the PLC CPU. This error may occur at system startup. The Ethernet Interface time and date are initialized to 00:00:00, 01-JAN-1989. <b>Entry 3</b> indicates the reason for this error: 0 Unable to retrieve information from the PLC CPU. This error will occur if the Ethernet Interface is not configured in the PLC CPU via the LM90 Configuration Software. 1 Invalid date/time value retrieved from the PLC CPU. The Ethernet Interface cannot accept dates prior to 01-JAN-1989. Check that the current date and time are established in the PLC CPU via the LM90 Configuration Software.</p>

**Table 9-10. Exception Log Event Codes - Continued**

Log Event Code	Possible Cause and Resolution
Event "2" System events (Continued)	<p>SystemError: 190                      This error occurs when the MMS provider is unable to attach to system association channels. This is an internal software error and should be reported to GE Fanuc - NA.</p> <p>SystemError: 1f4                      This error occurs when the Transport layer is unable to attach to SDM Channel B. Normal MMS communication is not possible. This is an internal software error and should be reported to GE Fanuc - NA.</p> <p>SystemError: 385                      This error occurs when a request is made for memory and no memory of the requested size or larger is available. The size of the request is stored in <b>Entry 3</b> of the log event. This error can be caused by:</p> <ul style="list-style-type: none"> <li>- Misconfigured memory pool sizes or percentages.</li> <li>- Misconfigured parameter (lmaxdb) causing excessive LLC demands for memory on the Ethernet Interface.</li> <li>- True exhaustion of memory resources due to insufficient processing capacity at the station, excessively long PLC scan time, or excessive network traffic addressed to the station.</li> <li>- System software error.</li> </ul> <p>SystemError: 386                      This error is caused by a request to release a buffer which is not a recognizable buffer from the system. This is a catastrophic system software error and should be reported to GE Fanuc - NA. The Ethernet Interface is automatically restarted.</p> <p>SystemError: 389                      This error occurs when the system is unable to allocate a buffer for CRC calculation use. Further background CRC checking cannot be performed. <b>Entry 3</b> indicates the required buffer size. Check the system buffer pools to see that a buffer of required size is available; adjust system buffer pool sizes and/or allocations if necessary.</p> <p>SystemError: 398                      This error occurs when the MMS Object Manager is unable to allocate a VMD machine. Normal MMS communication is not possible. This error is usually accompanied by a System Error 385, indicating that system buffer memory was not available. Check system buffer pools to see that a buffer of required size is available; adjust system buffer pool sizes and/or allocations if necessary.</p> <p>SystemError: 3e7                      This error is caused by a request to release a buffer which is either still on a queue or not on an even boundary. This is a catastrophic system software error and should be reported to GE Fanuc - NA. The Ethernet Interface is automatically restarted.</p> <p>SystemError: bbbb                      This error occurs when the battery is disconnected or running low. <b>Entry 3</b> indicates what type of transition has occurred:</p> <ul style="list-style-type: none"> <li>0 Battery went from good to bad.</li> <li>1 Battery went from bad to good (does not cause the STATUS LED to go OFF).</li> </ul>

Table 9-10. Exception Log Event Codes - Continued

Log Event Code	Possible Cause and Resolution
Event "2" System events (Continued)	<p>System Error: cccc</p> <p>This error occurs when the system detects an incorrect checksum in the software or configuration data loaded into memory. This is a catastrophic error. The Ethernet Interface is restarted with entry into the softwareLoadUtility.</p> <p><b>Entry 3</b> indicates the correct checksum value.</p> <p><b>Entry 4</b> indicates the actual computed value.</p> <p><b>Entry 5</b> indicates the internal range number within the software; range 0 indicates an error within the configuration data; Range ee indicates an error within the copy of EEPROM data. Occurrence of this error should be reported to GE Fanuc - NA.</p>
Event "3" NetworkLayer events	<p>This event is logged by the Network Layer (Internet) software when an unexpected error occurs.</p> <p><b>Entries 1, 4, 5</b> are used by GE Fanuc - NA support personnel to determine which software component raised the error.</p> <p><b>Entry 2</b> of the event log is an error code which indicates what error has occurred. Each error is described below.</p> <ul style="list-style-type: none"> <li>0 Could not QAlloc a buffer.</li> <li>2 Internet scheduled with invalid event.</li> <li>4 PDU Buffer pointer unexpectedlyNULL.</li> <li>5 NSAP address unexpectedlyNULL.</li> <li>6 Could not queue work item.</li> <li>8 Foreign NSAP table overflow, PDU discarded.</li> <li>9 BuffAlloc failed. <b>Entry 4</b> contains the byte size of the buffer we attempted to allocate.</li> <li>a SREAreq call failed.</li> <li>b Dequeue failed from Output Message Queue.</li> <li>c nternet header buffer unexpectedlyNULL.</li> <li>f Received NPDU with active Internet header and no data.</li> <li>11 Have reconstructed TPDU and have no place to send it.</li> <li>12 Could not create a buffer pool. It is likely that system memory configuration parameters need adjustment.</li> <li>13 Could not create a queue header. It is likely that system memory configuration parameters need adjustment.</li> <li>14 Request to set a timer failed.</li> <li>15 NSAP too long.</li> <li>16 Detected 2 stations on network with the same NSAP.</li> <li>17 GSM has configured duplicate entries for the RIB table. <b>Entry 4</b> contains the GSM RIB table entry number of the offending entry. <b>Entry 5</b> is 0 for an End System (ES) or 1 for an Intermediate System (IS).</li> </ul>

**Table 9-10. Exception Log Event Codes - Continued**

Log Event Code	Possible Cause and Resolution
Event "4" Transport Layer events	<p>This event is logged by the Transport Layer software when an unexpected event occurs.</p> <p><b>Entries 1, 4, 5 and 6</b> of the event log will be zero. For some errors, <b>Entry 3</b> of the event log will give the value of the bad Transport parameter.</p> <p>Entry 2 of the event log is an exception code which indicates what error has occurred for a received Transport Protocol Data Unit (TPDU). Each error is described below.</p> <ul style="list-style-type: none"> <li>0 InvalidTPDU. <b>Entry 3</b> specified error that occurred: <ul style="list-style-type: none"> <li>0 Length Indicator (LI) field is 255, which is invalid length.</li> <li>1 BadNSAP</li> <li>2 BadTSAP</li> </ul> </li> <li>1 Bad input TPDU type.</li> <li>2 No state machine for Acknowledgement (AK), Expedited Acknowledgement (EA), Data (DT), or Expedited Data (ED) TPDU.</li> <li>3 Invalid Gracefully close Request (GR) TPDU.</li> <li>4 Unsupported Expedited Data (ED) TPDU.</li> <li>5 Unsupported Expedited Acknowledgement (EA) TPDU.</li> <li>6 Invalid TPDU size.</li> <li>7 Bad parameter code. The value of the code is placed in event log <b>Entry 3</b>.</li> <li>8 Length Indicator (LI) is too short or too long. <ul style="list-style-type: none"> <li>a Checksum parameter not present.</li> <li>b Data (DT) TPDU data too large. The size of the data is placed in event log <b>Entry 3</b>.</li> <li>c Expedited Data (ED) TPDU data too large. The size of the data is placed in event log <b>Entry 3</b>.</li> <li>d Disconnect Request (DR) TPDU data too large. The size of the data is placed in event log <b>Entry 3</b>.</li> </ul> </li> </ul>
Event "5" Session Layer events	<p>This event is logged by the Session Layer software when an unexpected event occurs.</p> <p><b>Entries 1, 4, 5, and 6</b> of the event log will be zero.</p> <p><b>Entry 2</b> of the event log is an exception code which indicates what error has occurred for a received Session Protocol Data Unit (SPDU). Each event is described below.</p> <ul style="list-style-type: none"> <li>0 Attempt to get a new FSM failed.</li> <li>1 Attempt to get system structure failed.</li> <li>2 Wrong FSM state for attempted operation.</li> <li>3 Bad SSAP on incoming Connect (CN) SPDU.</li> </ul>
Event "6" Presentation Layer events	<p>This event is logged by the Presentation Layer software when an unexpected event occurs. <b>Entries 1, 3, 4, 5, and 6</b> will be zero. <b>Entry 2</b> of the event log is an exception code which indicates what event has occurred. It may have the following value:</p> <ul style="list-style-type: none"> <li>00 Unknown PSAP on incoming connect request PDU.</li> </ul>

Table 9-10. Exception Log Event Codes - Continued

Log Event Code	Possible Cause and Resolution
Event "7" ApplicationLayer events	<p>This event is logged by the Application Layer software when an unexpected event occurs. <b>Entries 1</b> and <b>6</b> of the event log will be zero. For some events, <b>Entries 3, 4,</b> and <b>5</b> will give more information on the event.</p> <p><b>Entry 2</b> of the event log is an exception code which indicates what event occurred. <b>Entry 2</b> may have the following values:</p> <ul style="list-style-type: none"> <li>1 Attempt to activate a User Element (UE) failed. <b>Entry 4</b> contains the UE ID. <b>Entry 5</b> contains the status returned from the MMS Provider. The possible error values are: <ul style="list-style-type: none"> <li>5 Maximum number of pending transactions exceeded.</li> <li>6 Maximum number of associations exceeded.</li> <li>b Internalresourcesunavailable.</li> <li>c Nonindications/ confirms to receive.</li> <li>e Interface unable to receive information.</li> <li>10 Invalid service to send with this function call.</li> <li>11 Variable name too long.</li> <li>12 Variable name too short.</li> <li>17 Invalid data type.</li> <li>1d Character string too long.</li> <li>1e Character string too short.</li> <li>29 Mandatory field is missing.</li> <li>2a Invalid count field.</li> <li>31 Invalidservice/primitiveombination.</li> <li>50 Cannot register with server below.</li> <li>51 Specified Application Entity is already active.</li> <li>52 At least one association still exists.</li> <li>5a Cannot deregister from server below.</li> <li>5f Cannot get system ID from server below.</li> <li>60 Maximum message size is smaller than the minimum value.</li> <li>61 Maximum message size is larger than the maximum value.</li> <li>96 Invalid User Element ID specified.</li> <li>97 InvalidassociationIDspecified.</li> <li>98 Specified Application Entity is not active.</li> <li>99 Specified association does not exist.</li> <li>9a Parameter buffer not NULL when it should be.</li> <li>9b Service negotiated off.</li> <li>9c Attempt to build message failed.</li> <li>a0 NULL event procedure not allowed on activate.</li> <li>a1 NULL APT not allowed on activate.</li> <li>a2 Unsupported ACN used.</li> <li>a3 Maximum number of Application Entities already active.</li> <li>aa Invalid primitive for this function call.</li> <li>ab Pass through mode used incorrectly.</li> <li>ac Invalidprimitive/service pair for state.</li> <li>ad Output message queue is full.</li> <li>b4 MMS version number must 1 or 0.</li> </ul> </li> </ul>



**Table 9-10. Exception Log Event Codes - Continued**

Log Event Code	Possible Cause and Resolution	
Event "7" ApplicationLayer events (Continued)	2	Invalid state/event pair passed into state machine. <b>Entry 4</b> contains the current state. <b>Entry 5</b> contains the current event.
	3	Download segment was received for domain not in download mode. <b>Entry 4</b> contains the UE type. <b>Entry 5</b> contains the UE ID.
	4	Domain was discarded. <b>Entry 5</b> contains an exception code used by GE Fanuc Automationsupportpersonnel.
	5	Invalid data, data type, or data type len on an incoming InformationReport indication. <b>Entry 4</b> contains the received data type. <b>Entry 5</b> contains the received data type length.
	6	Error during initialization of ApplicationInterface.
	7	Invalid event caused scheduling of ApplicationInterface. <b>Entry 4</b> contains the invalid event code. <b>Entry 4</b> contains the associatedparametervalue.
	8	Attempted send from the local Application to the MMS Provider failed. <b>Entry 4</b> contains the status code returned by the MMS Provider. <b>Entry 5</b> contains the UE ID. This exception log event will be generated when an MMS message would exceed the negotiated Maximum MMS Message Size value. The initiator should reduce the amount of data to be transferred, or increase the Maximum MMS Message Size (and possibly the System Buffer Size and Allocation) parameters.
	9	Type mismatch on a Read confirm. <b>Entry 4</b> contains the received data type. <b>Entry 5</b> contains the received data type length.
	A	MMS Responder received an unsolicited data indication. <b>Entry 4</b> contains the MMS command code received.
	B	A BuffAlloc request failed. <b>Entry 4</b> contains the number of bytes requested.
	C	A QAlloc request failed. <b>Entry 4</b> contains the number of bytes requested.
	D	An internal data formatting error occurred.
	E	Received a bad start/stop response from the CPU.
	F	Received a start/stop response from the CPU for an unknown PI.
	10	Received a start/stop response from the CPU for a non-existent association.
	11	Incoming indication could not be made to ladder program because maximum number of indications has already been met. If the indication is a confirmed service, a Negative Response will be sent back. If the indication is an unconfirmed service, the association will be aborted.
	12	Attempt to update the Association Control Block failed.

Table 9-10. Exception Log Event Codes - Continued

Log Event Code	Possible Cause and Resolution
Event "8" PLC Driver events	<p>This event is logged by the PLC Backplane Driver when an unexpected event occurs. <b>Entries 1 and 6</b> of the event log will be zero. For some events, <b>Entries 3, 4 and 5</b> will give more information on the event.</p> <p><b>Entry 2</b> of the event log is an exception code which indicates what error occurred. In general, <b>Entry 2</b> codes 1 - 1F are PLC backplane communication faults, codes 20 - 2F are resource errors, and codes 30 and up are miscellaneous errors. <b>Entry 2</b> may have the following values.</p> <ol style="list-style-type: none"> <li>1 Could not open VME mailbox. <b>Entry 4</b> contains the status returned from the MBU_OPEN routine. <b>Entry 5</b> contains the number of open attempts we made.</li> <li>2 Could not enable interrupt capability for incoming mail. <b>Entry 4</b> contains the returned status from the MBU_ENAB_INT routine.</li> <li>3 Mail packets from PLC for a read response are out of order. <b>Entry 4</b> contains the received packet sequence number. <b>Entry 5</b> contains the expected packet sequence number.</li> <li>4 PLC completed a response earlier than expected. <b>Entry 4</b> contains the current transfer state.</li> <li>5 Message from PLC for unknown Ethernet Interface task. <b>Entry 4</b> contains the task ID received from the PLC.</li> <li>6 Received PLC response for unknown request. <b>Entry 4</b> contains the mailbox sequence number of the stray response.</li> <li>7 Bad message type from PLC. <b>Entry 4</b> contains the message type code received.</li> <li>8 Timed out waiting for PLC response. <b>Entry 4</b> contains the mailbox sequence number for this transaction. <b>Entry 5</b> contains the transfer state when the timeout occurred.</li> <li>9 CPU completed program download before Ethernet Interface was ready.</li> <li>A CPU still wants program upload data when Ethernet Interface finished.</li> <li>20 QCreate call failed.</li> <li>21 PoolAlloc call failed.</li> <li>22 QAlloc call failed. <b>Entry 4</b> contains the byte size requested.</li> <li>23 BuffAlloc call failed. <b>Entry 4</b> contains the byte size requested.</li> <li>24 Circular mail queue is full and incoming message was lost. <b>Entry 4</b> contains the number of lost entries so far.</li> <li>25 "LANI/FCapacityExceeded; Discarded Request" A Dual Port Memory allocation attempt for a given length failed. <b>Entry 4</b> contains the length of the allocation.</li> <li>26 "LANSystem-SoftwareFault; Resuming" An attempt was made to free a Dual Port Memory buffer that is out of range.</li> <li>27 "LANSystem-SoftwareFault; Resuming" An attempt was made to free a Dual Port Memory buffer that is not allocated.</li> </ol>

**Table 9-10. Exception Log Event Codes - Continued**

Log Event Code	Possible Cause and Resolution
Event "8" PLC Driver events (Continued)	<p>30 Could not generate work queue entry. <b>Entry 4</b> contains the event that was trying to be scheduled, which is one of the following:</p> <p style="margin-left: 20px;"><u>Entry 4 Description</u></p> <ol style="list-style-type: none"> <li>1 Mail message received from PLC</li> <li>2 Ethernet Interface timed out waiting for a response from the CPU</li> <li>3 Received mail message for diagnostics task</li> <li>4 Circular queue full, mail message dropped</li> <li>5 Retrying VME mailbox initialization</li> </ol> <p style="margin-left: 20px;">Entry 5 contains additional information related to the event type.</p> <p style="margin-left: 20px;"><u>Entry 5 Interpretation</u></p> <ol style="list-style-type: none"> <li>1 Ethernet Interface task ID to which message was sent</li> <li>2 Index into Data Transfer table of transaction</li> <li>3 Ethernet Interface task ID to which message was sent</li> <li>4 Number of messages dropped so far</li> <li>5 Number of open attempts so far</li> </ol> <p>31 Backplane Driver scheduled with illegal event. <b>Entry 4</b> contains the event code received.</p> <p>32 Illegal COMM_REQ from application program was discarded. <b>Entry 4</b> contains the command code received.</p> <p>33 COMM_REQ received outside of normal system operation (e.g., while in the Soft Switch editor).</p> <p>34 Backplane Driver initializing without Soft Switches from the CPU. This will occur if the LAN Interface is not configured in the PLC via the Logicmaster 90-70 Configuration Software.</p> <p>35 Series 90-70 Ethernet Interface/CPU communication timeout during restart or load.</p> <p>36 "Bad Local Application Request; Discarded Request" A COMM_REQ received from the Series 90-70 ladder program was not allowed because the Ethernet Interface has not yet received soft switches from the CPU. Entry 4 shows the COMM_REQ command number.</p> <p>37 "LAN System-Software Fault; Resuming" A task that has not registered with the Backplane driver is attempting to send messages to the PLC.</p> <p>38 A Backplane driver user's attempt to send a message to the PLC failed. <b>Entry 3</b> indicates the error code returned.</p> <p>39 An attempt to release CPU text buffers failed. <b>Entry 3</b> indicates the status returned from the Mailbox Utilities.</p> <p>40 Backplane driver's attempt to send a message to the PLC failed. <b>Entry 3</b> indicates the status code returned from the CPU.</p> <p>41 Backplane driver could not find a state machine for an unsolicited message.</p> <p>42 Backplane driver could not find a state machine for a response message.</p>

Table 9-10. Exception Log Event Codes - Continued

Log Event Code	Possible Cause and Resolution
Event "9" SRTP Service Agent events	<p>This event is logged by the SRTP Service Agent when an unexpected event occurs. <b>Entry 2</b> of the logged event contains one of the following error codes.</p> <ul style="list-style-type: none"> <li>0 "LANSystem-SoftwareFault; Resuming" The number of available connections between Logimaster and the CPU has been exceeded.</li> <li>1 "Bad Local Application Request; Discarded Request" Invalid Transport Connect request was Acknowledged.</li> <li>2 "Bad Local Application Request; Discarded Request" Invalid Transport Expedited request made.</li> <li>3 "LANSystem-SoftwareFault; Resuming" The transaction with the given sysid was not found.</li> <li>4 "LANSystem-SoftwareFault; Resuming" Backplane driver ready indication with the given transfer id was not found.</li> <li>5 "LANSystem-SoftwareFault; Resuming" Message response indication with the given transfer id was not found.</li> <li>6 "LANSystem-SoftwareFault; Resuming" Invalid next data indication from the Backplane driver.</li> <li>7 "LANSystem-SoftwareFault; Resuming" Unrecognized PDU was received.</li> <li>8 "LANSystem-SoftwareFault; Resuming" Invalid binding for the received PDU.</li> <li>9 "Backplane Communications with PLC Fault; Lost Request" Backplane driver returned bad status. <b>Entry 3</b> provides the list of status's that can be returned from the Backplane driver <ul style="list-style-type: none"> <li>2 The Backplane driver could not access the PLC.</li> <li>3 Invalid binding on the PDU sent to the Backplane driver.</li> <li>4 The message could not be sent to the CPU because the VME mailbox was not open.</li> <li>5 The Maximum transfers to the CPU are already taking place.</li> <li>6 Maximum number of this transfer type are already taking place.</li> <li>7 Cannot obtain a Dual-Port RAM buffer.</li> <li>8 Cannot obtain resources (other than Dual-Port RAM).</li> <li>9 Connection ID or block transfer id is not valid <ul style="list-style-type: none"> <li>a Timed out waiting for CPU response.</li> <li>b The CPU aborted the request.</li> <li>c Invalid message type was specified.</li> <li>d Specified task is not registered.</li> <li>e Mailbox offset specified is invalid.</li> <li>f Argument "msg_rsp" may not be NULL.</li> </ul> </li> <li>10 Argument "unsol_rsp" may not be NULL.</li> <li>11 Parameter pointer unexpectedly NULL.</li> <li>12 More than allowable byte length on one transfer.</li> <li>13 Bad sequence number in the request.</li> <li>14 Invalid command in request.</li> </ul> </li> </ul>

**Table 9-10. Exception Log Event Codes - Continued**

Log Event Code	Possible Cause and Resolution
Event "9" SRTP Service Agent events (Continued)	<ul style="list-style-type: none"> <li>a "Backplane Communications with PLC Fault; Lost Request" CPU NACKed Establish session request.</li> <li>b "Backplane Communications with PLC Fault; Lost Request" CPUNACKed Terminate session request.</li> <li>c "LANSystem-SoftwareFault; Resuming" Request received with Connection machine in wrong state.</li> <li>d "LANSystem-SoftwareFault; Resuming" Connection state machine failed action routine.</li> <li>e "LANSystem-SoftwareFault; Resuming" SRTP Service Agent could not attach to the SDM.</li> <li>f "LANSystem-SoftwareFault; Resuming" Unsolicited message for task which is not connected to this board.</li> <li>10 "LANSystem-SoftwareFault; Resuming" Request state machine had an invalid state/event sequence.</li> <li>11 "LANSystem-SoftwareFault; Resuming" The number of bytes of data actually received is not equal to the size specified in the SRTP header.</li> </ul>
Event "a" COMM_REQ MDB events	<p>This event is logged whenever a COMM_REQ is received whose Message Definition Block (MDB) contains a word that cannot be interpreted. <b>Entry 2 - Entry 5</b> of the event contain the first 4 words of the MDB. This is an application error. Check the values of all words associated with COMM_REQ instructions to be sure that they point to a valid MDB. Each COMM_REQ will receive a "COMM_REQ Complete With Error" status and no processing will be done on the MDB.</p>
Event "b" MMS Service Agent events	<p>This event is logged when the MMS Service Agent encounters an unexpected event.</p> <p><b>Entry 2</b> of the logged event contains one of the following error codes.</p> <ul style="list-style-type: none"> <li>1 "LANSystem-SoftwareFault; Resuming" Could not find the index into the Data Transfer Table.</li> <li>2 "LANSystem-SoftwareFault; Resuming" Backplane driver returned a bad status. <b>Entry 3</b> contains status code.</li> <li>3 "Backplane Communications with PLC Fault; Lost Request" CPUNacked a request. <b>Entry 3:</b> Major status. <b>Entry 4:</b> Minor Status. These are error codes returned by the CPU. See Table 16 and 17 in GFK-0582B.</li> <li>4 "Backplane Communications with PLC Fault; Lost Request" A read request returned an unexpected amount of data. <b>Entry 3</b> contains the actual data size; <b>Entry 4</b> contains the expected data size.</li> <li>5 "LANSystem-SoftwareFault; Resuming" Unexpected "More follows" condition was indicated by the Backplane driver.</li> <li>6 "Backplane Communications with PLC Fault; Lost Request" Unexpected Unsolicited message type was received. <b>Entry 3</b> contains the message type code.</li> <li>7 "Backplane Communications with PLC Fault; Lost Request" CPUNACKed a request 3 times due to congestion. <b>Entry 3</b> contains the status code; <b>Entry 4</b> contains additional status data.</li> </ul>

Table 9-10. Exception Log Event Codes - Continued

Log Event Code	Possible Cause and Resolution
Event "c" LLC events	<p>This event is logged when the LLC layer encounters an unexpected condition. <b>Entry 2</b> of the logged event contains the error code as shown below.</p> <p>102 "LAN Transceiver Fault; Attempting Recovery": Either the Transceiver or Transceiver cable failed or became disconnected. Reattach the cable or replace the Transceiver or cable. If SQEErr is incrementing but LostCarr is not, the Transceiver SQE-test switch may be set incorrectly. Transceivers used on GENet must have the IEEE 802.3 SQE_TEST enabled. Use the TALLY L cmd to distinguish whether the SQE test, done on each transmitted frame, failed (SQEErr) or the transceiver lost carrier while transmitting (LostCarr). Online operation should resume within 10 seconds after repair.</p> <p>103 "LAN Data Memory Exhausted - Check Params; Resuming": The MAC device discarded a receive frame because there was no buffer to receive the frame into. More input buffers should be allocated to the MAC by increasing the parameter <i>lrxringlen</i>. The TALLY L cmd will distinguish whether there were simply no receive buffers (MisDPack) or an excessively long frame that required chaining of multiple buffers (RbufErr).</p> <p>105 "LAN Controller Tx Underflow; Attempting Recovery": During transmission, the MAC was unable to get data from memory quickly enough. This indicates a LAN Controller design flaw; it should not occur. This error may cause loss of both tx and rx messages that are in process, since the MAC must be reinitialized (done automatically). Online operation should resume within 10 seconds after repair.</p> <p>106 "Bad Remote Application Request; Discarded Request": An incoming frame was received that exceeded the size specified by the parameter <i>lmaxdb</i>. For frame types other than TEST frames, the frame was discarded; for TEST frames, the data within the frame was discarded and the frame was processed without data. Check the remote (sending) station for correct frame length. If the local station must correctly receive frames of large size, it will be necessary to increase the parameters <i>lmaxdb</i> and <i>bbuf4</i> and possibly reallocate data memory via <i>balloc1</i>, <i>balloc2</i>, <i>balloc3</i>, and <i>balloc4</i>. Consult GE Fanuc if you need assistance. <b>Entries 3, 4 and 5</b>, taken together, show the MAC address of the sending station.</p> <p>107 "Bad Remote Application Request; Discarded Request": An unsolicited XID response frame was received. This can be caused by a protocol error in a remote station. <b>Entries 3, 4 and 5</b>, taken together, show the MAC address of the sending station.</p> <p>108 "Bad Remote Application Request; Discarded Request": An unsolicited TEST response frame was received. This is usually caused when a remote station responds too slowly to a TEST Station Manager command from the reporting station. Increase the value of the TEST &lt;sch&gt; parameter. If the problem persists and the reporting station is not sending a TEST cmd, then some remote station on the network is generating a protocol error. <b>Entries 3, 4 and 5</b>, taken together, show the MAC address of the sending station.</p>

**Table 9-10. Exception Log Event Codes - Continued**

Log Event Code	Possible Cause and Resolution
Event "c" LLC events (Continued)	<p>10a "LAN Severe Network Problem; Attempting Recovery". Repeated collisions caused the transmitter to fail 16 attempts to send a frame. If the LAN stays Offline, it is likely caused by a damaged or unterminated trunk cable. (This report may occasionally be caused by extremely heavy network traffic.) Online operation should resume within 10 seconds after repair.</p> <p>10b "LAN Severe Network Problem; Attempting Recovery": During attempted transmission, either some external condition prevented transmission of a frame for at least one second (MacErr) or a late collision occurred (Late Coll). Use the TALLY L cmd to distinguish. If MacErr is incrementing every 10 seconds, the transceiver is likely hearing constant carrier on the network. This can be caused by disconnection of the transceiver from the network or by a faulty connection of the transceiver to the network, it can also be caused by test equipment attached to the network, or to a remote failed transceiver. Are other nodes reporting the same fault? (MacErr may occasionally be caused by extremely heavy network traffic.) LateColl indicates a protocol violation by a remote station; the tx frame may be lost. Online operation should resume within 10 seconds after repair.</p> <p>10e "LAN Controller Underrun/Overrun; Resuming". During receiving, the MAC was unable to write data into memory quickly enough. This indicates a LAN Controller design flaw; it should not occur. The frame being received is discarded. Online operation continues.</p> <p>10f "LAN Network Problem Exists; Performance Degraded": Excessive backlog of transmission requests due to excessive traffic on the network. For a sustained period, the MAC was unable to send frames as quickly as requested.</p> <p>110 "Bad Local Application Request; Discarded Request" The LLC rejected a local application request to send a frame because the frame length was invalid. IEEE 802.3 frames must not exceed 1497 bytes of LLC data. Ethernet frames must contain 46-1500 bytes of LLC data.</p> <p>111 "LAN Duplicate MAC Address; Resuming": A frame was received in which the Source Address was the same as this station's MAC Address. All stations on a network must have a unique MAC address. Immediately isolate the offending station; it may be necessary to turn it off or disconnect it from the network. This station remains Online unless you intervene to take it Offline.</p>

**Table 9-10. Exception Log Event Codes - Continued**

Log Event Code	Possible Cause and Resolution
Event "c" LLC events (Continued)	<p>120* "LAN Controller Fault;RestartedLANI/F" or 121* "LAN Interface Hardware Failure; Switched Off Network": Fuse FU1 on the LAN Controller board, which protects the PLC Power Supply from overload from the external transceiver, is blown. This fuse is not field replaceable. Correct the external fault and replace the LAN Controller board.</p> <p>122* "LAN Controller Fault;RestartedLANI/F" or 123* "LAN Interface Hardware Failure; Switched Off Network": The MAC chip failed its internal loopback test. Replace the LAN Controller board.</p> <p>124* "LAN Controller Fault;RestartedLANI/F" or 125* "LAN Interface Hardware Failure; Switched Off Network": The MAC chip failed to initialize. Replace the LAN Controller Board.</p> <p>126* "LAN Controller Fault;RestartedLANI/F" or 127* "LAN Interface Hardware Failure; Switched Off Network": The MAC reported a "babble" fault; more than 1518 bytes of data have been transmitted in a frame. Replace the LAN Controller board.</p> <p>128* "LAN Controller Fault;RestartedLANI/F" or 129* "LAN Interface Hardware Failure; Switched Off Network": The MAC reported a handshaking error in accessing the LAN Controller memory. Replace the LAN Controller board.</p> <p>12a* "LAN Controller Fault;RestartedLANI/F" or 12b* "LAN Interface Hardware Failure; Switched Off Network": The MAC reported a broken "chain" of buffers in a transmit frame. Since the LAN Controller does not chain buffers, this should not occur. Replace the LAN Controller board. If this fault recurs, please report it to GE Fanuc.</p>
	<p>* Same fault for both reports. It is remotely possible that error codes 120 - 12b may occur due to a transient system fault. Because of this possibility an attempt is made to recover without manual intervention, by restarting the LAN Controller (thus rerunning power-up diagnostics). If a hardware fault is detected, the LAN Controller will be held in reset. To prevent repeated restarts and to protect the network, the LAN IF will instead Switch Offline from the Network (rather than Restart) if this fault occurs within 5 minutes of startup.</p>



**Table 9-10. Exception Log Event Codes - Continued**

Log Event Code	Possible Cause and Resolution
Event "e" MMS Provider events	<p>This event is logged by the MMS Provider software when an unexpected event occurs.</p> <p><b>Entry 1</b> of the event log will be zero.</p> <p><b>Entry 3</b> of the event log specifies a "module" code which can be used by GE Fanuc - NA support personnel to determine which software component raised the exception.</p> <p>For some events, <b>Entries 4, 5, and 6</b> give more information about the event.</p> <p><b>Entry 2</b> of the event log is an exception code which indicates what error has occurred. Each event is described below.</p> <ul style="list-style-type: none"> <li>0 Duplication of a <i>sysid</i></li> <li>1 Unable to allocate a protocol machine.</li> <li>2 Unable to allocate a work queue entry.</li> <li>3 Error return from a sys-replace.</li> <li>4 Invalid UE ID.</li> <li>5 MaximumAssociationsexceeded.</li> <li>6 Task scheduled with no work to do.</li> <li>7 No transition was taken by the FSM.</li> <li>8 Noactionforstate/event pair.</li> <li>9 Unknown <i>sysid</i></li> <li>a QALLOC failed, memory resource problem.</li> <li>b BUFFALLOC failed, memory resource problem.</li> <li>c APTitlemismatch.</li> <li>d MMS parse attempt failed.</li> <li>e MMS build failed.</li> <li>f Unexpected user PDU.</li> <li>10 Error return from LDATA_ACK request.</li> <li>11 Unexpected service from LLC.</li> <li>12 Unexpected service from SDM.</li> <li>13 miniMAP service invalid (MAP Interface only).</li> <li>14 miniMAP internal error (MAP Interface only).</li> <li>15 miniMAP PDU abandoned for no Association (MAP Interface only).</li> <li>16 Received partial data from lower layer.</li> <li>17 Parameter on incoming initiate response is inappropriate. <b>Entry 4</b> describes which parameter is in error: <ul style="list-style-type: none"> <li>1 Maximum message size is too large. <b>Entry 5</b> contains the maximum size that is currently configured on this station (see the "Maximum MMS Message Size Menu" description in Chapter 3), and <b>Entry 6</b> contains the message size negotiated by the called station.</li> <li>2 Maximum message size is too small. <b>Entry 5</b> contains the smallest supported value for this parameter (not configurable) and <b>Entry 6</b> contains the message size negotiated by the called station.</li> </ul> </li> </ul>

Table 9-10. Exception Log Event Codes - Continued

Log Event Code	Possible Cause and Resolution
Event "e" MMS Provider events (Continued)	<p>3 MMS version number was negotiated upwards. The negotiated version number must be equal to or lower than the proposed version number. <b>Entry 5</b> contains the version number that was proposed on the outgoing initiate request and <b>Entry 6</b> contains the received negotiated version number.</p> <p>4 Nesting level was negotiated upwards. The negotiated nesting level must be equal to or lower than the proposed nesting level. <b>Entry 5</b> contains the nesting level that was proposed on the outgoing initiate request and <b>Entry 6</b> contains the received negotiated nesting level.</p> <p>5 Maximum outstanding messages (calling) was negotiated upwards. The negotiated value must be equal to or lower than the proposed value. <b>Entry 5</b> contains the value that was proposed on the outgoing initiate request and <b>Entry 6</b> contains the received negotiated value.</p> <p>6 Maximum outstanding messages (called) was negotiated upwards. The negotiated value must be equal to or lower than the proposed value. <b>Entry 5</b> contains the value that was proposed on the outgoing initiated request and <b>Entry 6</b> contains the received negotiated value.</p> <p>18 InvalidInvoke ID. Must not be a duplicate of Invoke ID used in any outstanding transaction for this association. It may also indicate that the maximum number of transactions for this association has been exceeded.</p>
Event "10" Directory User Agent events	<p>This event is logged by the Directory User Agent when an unexpected event occurs.</p> <p><b>Entry 2</b> is an exception code that indicates what error has occurred. Each event is described below.</p> <p>d The Distributed Directory Protocol in the DUA received a Name Conflict Advise indication from another node on the network. This means that a remote DDP device is already using the name that the local node is trying to register</p>

## Extended Status Buffer Negative Values

The following negative values may occur either in the Extended Status Buffer “Error code” field or in the Association Control Block “Problem Code” field.

**Table 9-11. Negative Extended Status Buffer Values**

Error or Problem Code		Interpretation of Code
Decimal	Hexadecimal	
-1	FFFF	Data received is in an unexpected (not in format requested) or bad format.
-2	FFFE	Could not transfer the data to the PLC.
-3	FFFD	Encountered buffer resource problems.

## Extended Status Buffer Errors

The error codes below appear in the Extended Status Buffer when a ladder logic command to the Ethernet Interface cannot be processed. To view the Extended Status Buffer, issue the EXS command from the Station Manager.

**Table 9-12. Extended Status Buffer Error Codes and Definition**

Error Code dec (hex)	Description
PLC Backplane Driver Errors	
74 (4A)	Buffer allocation problems
75 (4B)	Invalid COMM_REQ command code
76 (4C)	Bad system type (network test, Soft Switch editor, etc.) for COMM_REQs
77 (4D)	No COMM_REQs allowed, Backplane Online soft switch is set to “NO”.
78 (4E)	COMM_REQ received from the Series 90-70 ladder program was not allowed because the Ethernet Interface has not yet received Soft Switches from the CPU, or no Soft Switches are defined in the CPU.
System and Station Management Errors	
90 (5A)	Resource error; unable to get a buffer, etc.
91 (5B)	Invalid address in a station management transfer request.
92 (5C)	Zero length specified in a station management transfer request.
99 (63)	Invalid command in Message Definition Block.
Communication Errors	Codes 258-29c (hex) indicate errors that occur when an error condition occurs in a Communication Service request.
600 (258)	Resource error; unable to get a buffer.
601 (259)	Invalid communication service command number.
602 (25A)	Invalid parameter length.
603 (25B)	Invalid Application Process parameter.
604 (25C)	Unable to de-activate currently activated Application Process.
605 (25D)	Unable to activate Application Process.

Table 9-12. Extended Status Buffer Error Codes and Definitions - Continued

Error Code dec (hex)	Description
606 (25E)	Number of elements parameter may not be zero.
607 (25F)	Invalid Symbolic Address parameter. Must be of the form "R001", "I12", "AI7", etc.
608 (260)	Unable to define Variable Name. Either the define request parameters are invalid or the Variable Name Table is full.
609 (261)	Invalid Numeric Address Length parameter. This parameter must have the value of 4.
610 (262)	Unable to send message or response. Either an error in the message request or the message output queue is backed up.
611 (263)	Unable to form a new association because the maximum number of associations has already been established.
612 (264)	No Initiate Indication is pending.
613 (265)	Maximum Message Size parameter is smaller than the minimum maximum message size. (This parameter may be 0 to use the default maximum message size.)
614 (266)	Invalid Response Type parameter. This parameter must be 0 (for Positive Response) or 1 (for Negative Response).
615 (267)	Unable to build an MMS Initiate Request PDU. This may be because the station is not configured to support associations, the maximum message size was too small or too large, or system resources are not currently available.
616 (268)	Unable to send a message request because the maximum number of outstanding message transactions for this association has been exceeded.
617 (269)	The message transaction number matches the transaction number of a message whose response has not yet been received. (Transaction is still pending.)
618 (26A)	No message indication for this type of message is pending.
619 (26B)	Error occurred in the attempt to transfer data to/from the Series 90-70 PLC.
620 (26C)	Can only make message responses in this state.
621 (26D)	Invalid ACB Location parameter. Either an invalid Series 90-70 location or the ACB Location is already in use by another association.
622 (26E)	No Variable Name is specified in the request. (The Variable Name Length parameter is 0.)
623 (26F)	The Variable Name Length specified is longer than the maximum Variable Name Length.
624 (270)	The Variable Name, Application Process Title, or Application Context Name specified has an invalid ASCII character(s).
625 (271)	Invalid Data Type parameter. This parameter must have the value of one of the data types specified in Chapter 6, "Data Type Values".
626 (272)	Invalid Data Buffer parameter. The Data Buffer specified is not at all or is not entirely within the Series 90-70 PLC memory space.
627 (273)	Invalid Variable Type parameter. This parameter must have one of the values specified in Chapter 6, "Variable Type Values".

Table 9-12. Extended Status Buffer Error Codes and Definitions - Continued

Error Code dec (hex)	Description
628 (274)	InvalidFirstand/orLastIndex. Both index parameters must be non-zero and the Last Index parameter must be greater than or equal to the First Index parameter.
629 (275)	Invalid parameter Length. The parameter Length is longer than 4096 characters.
630 (276)	Invalid PLC Location parameter.
631 (277)	No association exists for the specified ACB Location.
632 (278)	No Address parameter. (The Address Length parameter is 0.)
634 (27A)	This command is not valid for the specified Application Process.
636 (27C)	No message indication of this message type is pending to examine.
637 (27D)	Invalid Examine request. No indications or initiate confirm pending to examine.
638 (27E)	No Status parameter. (The Status Length parameter is 0.)
639 (27F)	Invalid Status Length parameter. (The Status Length parameter must be 1.)
640 (280)	Invalid command for the state of the association. For example, if a Conclude Request has been made, the ladder logic cannot make any Message requests. (It may make message Response requests.)
642 (282)	Specified Application Process has not been activated. The specified Application Process must have an APT defined. The <i>applcnam</i> parameter must be defined. Also, the <i>applapt</i> parameter must not be equal to 0.
643 (283)	No Application Process Title is specified in the Initiate Request.
645 (285)	The Maximum message size specified in an Initiate response is larger than that proposed in the indication.
650 (28A)	No Program Invocation was specified in a Start, Stop, Restart or Resume.
651 (28B)	Invalid memory type in Read or Write.
653 (28D)	The Domain Name contains an invalid character or is too long.
654 (28E)	Invalid Scope parameters in Read, Write, or Information Request.
656 (290)	Data buffer size too small for Read, Write, or Information Report request.
658 (292)	Data buffer for Read or Write does not exist in PLC memory.
659 (293)	Invalid object class in GetNameList.
660 (294)	Application Domain discarded.
661 (295)	Program Invocation state error.
662 (296)	Invalid VMD status value specified.
663 (297)	Common Name missing or invalid.
664 (298)	Invalid Application Context.
665 (299)	Invalid Numeric Address.
666 (29A)	Inactive User Element.
667 (29B)	Context string inconsistent with context.
668 (29C)	Service has been negotiated off.
670 (29E)	Conclude (positive) Response COMM_REQ was not allowed because there are other outstanding MMS responses that must be processed before the association can be concluded.

Table 9-12. Extended Status Buffer Error Codes and Definitions - Continued

Error Code dec (hex)	Description
671 (29F)	Start/Resume argument is too long.
672 (2A0)	Resume argument not permitted in MMS DIS context.
673 (2A1)	Start/Resume argument contains illegal character.
674 (2A2)	Common name too long.
675 (2A3)	Invalid variable specification.
676 (2A4)	Invalid PI state.

## GENet LAN Interface Status Word

The GENet LAN Interface Status Word (LISW) is used to convey the health of the Ethernet Interface and the network to the application program. There are sixteen (16) dedicated bits which are updated by the Ethernet Interface software at every Ethernet Interface “communication window” (once per sweep when the Ethernet Interface is configured).

The figure below shows the definition of the bits in the LISW.

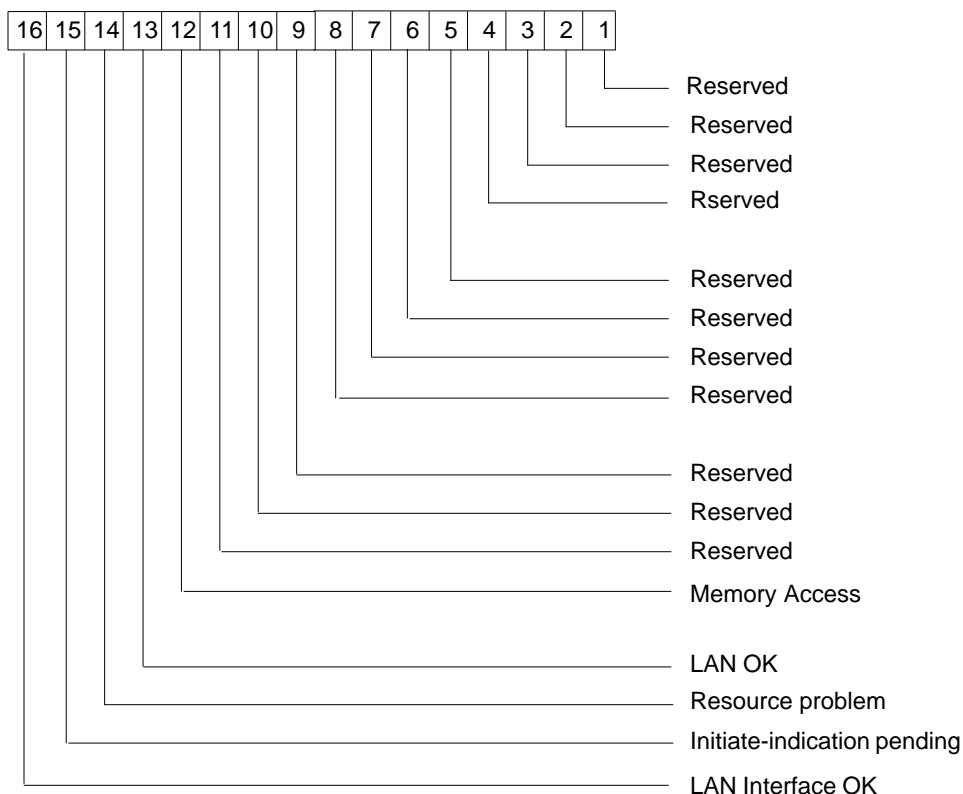

Figure 9-2. Meaning of GENet LAN Interface Status Inputs

Bits 1 through 11 are reserved for future expansion.

**Bit 12 (Memory Access)** is set to one (1) when a remote station on the network reads or writes data in the memory of the local PLC using the MMS Responder communication services. This input will be held high for at least one full PLC scan and then it will be set to 0.

**Bit 13 (LAN OK)** will be held at the value one (1) as long as the LAN Interface software is able to communicate on the network. If the network should become inaccessible from this station, due either to local or network problems, this input will be set to zero (0). This bit will also be set to zero if the Station Manager NET OFF command is used, or if the LAN Online Soft Switch is set to NO.

**Bit 14 (Resource Problem)** is set to one (1) whenever the LAN Interface software is experiencing resource problems. This is usually an indication that data from the network is being lost by the local station. This input will be held at the value of one (1) for as long as the resource problem occurs. It is guaranteed to remain 1 for at least one PLC scan before transitioning to 0.

**Bit 15 (Initiate-indication Pending)** is set to one (1) when a remote station on the network has requested the establishment of an association with the local application program. This input remains 1 until either the remote station gives up (aborts the attempt) or until the local application program responds to the initiate indication. If more than one initiate indication is pending, this input will remain 1 until all of the pending indications have either been aborted or been responded to by the application program. Otherwise this bit is zero (0).

**Bit 16 (LAN Interface OK)** is conditionally set to one (1) by the LAN Interface software at the end of every window. If the LAN Interface cannot access the PLC, the Series 90-70 CPU will set this bit to zero (0). A ladder program should always test that this bit is one (1) before issuing a COMM\_REQ to the LAN Interface. This bit will be zero (0) if the LAN Interface is not in the Operational state (e.g., if it is running the Loader or Field Network Test utilities) or if the Backplane Online soft switch is NO. When this bit is zero, none of the other bits in the LISW are valid.

In communications networking, a number of special terms are used. Also, many of these terms are referenced by acronyms. For example, a Programmable Logic Controller (PLC), computer or other device that connects to a network is called by the general name *station*.

This appendix contains a concise, alphabetized listing of conventional communications terms and (where applicable) their associated acronyms. Most of these terms (but not necessarily all) are used in this manual.

## Commonly Used Acronyms and Abbreviations

This is a listing of acronyms, and their derivation, that are commonly used throughout this manual.

<b>ACB</b>	AssociationControl Block
<b>ACN</b>	ApplicationContext Name
<b>ACSE</b>	AssociationControlService Element
<b>AE</b>	ApplicationEntity
<b>AP</b>	ApplicationProcess
<b>ASCII</b>	American National Standard Code for InformationInterchange
<b>ASE</b>	ApplicationService Element
<b>ASW</b>	AssociationStatusWord
<b>ASWE</b>	AssociationStatusWordExtension
<b>AUI</b>	Attachment Unit Interface
<b>BCD</b>	Binary Coded Decimal
<b>BPS</b>	Bits Per Second
<b>COMM_REQ</b>	COMMunicationREQuest
<b>CPU</b>	Central ProcessingUnit
<b>CSMA/CD</b>	Carrier Sense Multiple Access with Collision Detection
<b>DCE</b>	DataCommunicationsEquipment
<b>DDP</b>	DistributedDirectory Protocol
<b>DIB</b>	Directory Information Base
<b>DIS</b>	ISO "Draft InternationalStandard"
<b>DOS</b>	Disk OperatingSystem
<b>DTE</b>	Data TerminalEquipment
<b>DUA</b>	Directory User Agent
<b>EPROM</b>	ErasableProgrammable Read Only Memory
<b>GSM</b>	GENetSystem Manager
<b>H</b>	Hexadecimal
<b>I/O</b>	Input/Output
<b>IEEE</b>	Institute of Electrical and Electronics Engineers



---

<b>IRL</b>	Inter Repeater Link
<b>IS</b>	ISO "International Standard"
<b>ISO</b>	International Organization for Standardization
<b>K</b>	1024
<b>KB</b>	Kilobyte (1024 bytes)
<b>LAN</b>	Local Area Network
<b>LED</b>	Light Emitting Diode
<b>LISW</b>	LAN Interface Status Word
<b>LLC</b>	Logical Link Control
<b>LSAP</b>	Link Layer Service Access Point
<b>MAC</b>	Medium Access Control
<b>MAP</b>	Manufacturing Automation Protocol
<b>MAPDIB</b>	MAP Directory Information Base
<b>MB</b>	Megabyte (1,048,576 bytes)
<b>MDB</b>	Message Definition Block
<b>MDI</b>	Medium-Dependent Interface
<b>miniMAPDIB</b>	miniMAP Directory Information Base
<b>MMS</b>	Manufacturing Message Specification
<b>NDIS</b>	Network Driver Interface Specification
<b>NMA</b>	Network Management Agent
<b>NSAP</b>	Network Service Access Point
<b>OSI</b>	Open System Interconnection
<b>PC</b>	Personal Computer, IBM compatible
<b>PDU</b>	Protocol Data Unit
<b>PI</b>	Program Invocation
<b>PICS</b>	Protocol Implementation Conformance Statement
<b>PLC</b>	Programmable Logic Controller
<b>PSAP</b>	Presentation Service Access Point
<b>PROM</b>	Programmable Read Only Memory
<b>RAM</b>	Random Access Memory
<b>MDI</b>	Medium-Dependent Interface
<b>SAP</b>	Service Access Point
<b>SQE</b>	Signal Quality Error
<b>SRTP</b>	Service Request Transfer Protocol
<b>SSAP</b>	Session Service Access Point
<b>TPDU</b>	Transport Protocol Data Unit
<b>TSAP</b>	Transport Service Access Point
<b>UE</b>	User Element
<b>VMD</b>	Virtual Manufacturing Device
<b>VME</b>	Versa Module European

---

## Glossary of Terms

**Address Administration** The assignment of LAN addresses locally or on a universal basis.

**Address Field** The part of a Protocol Data Unit (PDU) that contains an address.

**Application Context Name (ACN)** An ASCII string of up to 64 Characters used to describe the context of each application.

**Application DIB (Directory Information Base)** A directory of 7-Layer Application Processes which supplies all addressing information needed to communicate with each 7-Layer Application Process. The GSM maintains a 7-Layer Application DIB containing the 7-Layer Application Processes defined by each configured station. Each MAP 3.0 and Ethernet station contains a Local Application DIB which defines those Application Processes with which the station will initiate 7-Layer communications. An Application DIB is sometimes referred to as a MAP DIB when using MAP communications.

**Application Entity (AE)** That part of the Application Process (AP) that processes a particular set of OSI communication services is known as an Application Entity (AE). Each AE is uniquely addressable in the network.

**Application Interface** The Application Interface services respond to and initiate requests to remote application processes via ladder logic programming and MMS messages. (See also "Hands-On Service").

**Application Layer** Layer 7 of the OSI Model. The services provided by this layer directly support application programs.

**Application Message** A communication request or response sent between application entities.

**Application Processes (AP)** The "parties" that are connected by an association. An element within a system which performs the information processing.

**Application Program** The ladder logic program executing in the PLC.

**ASCII Code** The American Standard Code for Information Interchange is an information code standard by which numbers, letters, symbols and control characters can be formed for serial transmission.

**Association** A logical connection which must be established between two Application Processes so that they may communicate with each other (Analogous to a telephone connection).

**Association Control Block (ACB)** A block of five words which is used to communicate between the Series 90-70 PLC ladder logic and the LAN Interface.

**Association Services** Communication services which allow the initiation, orderly conclusion, and abrupt conclusion of the association between the local and remote applications processes.

**Attachment Unit Interface** In a data station on a Local Area Network, the interface between the medium attachment unit and the data terminal equipment. Often called "transceiver cable".

- Baseband LAN** A local area network (LAN) in which data is encoded and transmitted without modulation of a carrier.
- Bit** Contraction of Binary Digit. The smallest unit of memory. Can be used to store one piece of information that has only two possible states or values (e.g., One/Zero, On/Off, Yes/No). Data that requires more than two states or values (e.g., numerical values) requires multiple bits (see Word).
- Broadcast Address** A LAN group address that identifies the set of all data stations on a Local Area Network.
- Bridge** A functional unit that interconnects two Local Area Networks (LAN's) that use the same logical link control protocol, but may use different medium access control protocols.
- Broadband LAN** A Local Area Network (LAN) consisting of more than one channel in which data is encoded, multiplexed, and transmitted with modulation of carriers.
- Broadcast** Sending of a frame that is intended to be accepted by all other data stations on the same Local Area Network.
- Broadband Networks** Handle medium-to-large size applications with up to several hundred stations as a typical number which might be attached. Broadband technology is used in larger networking systems and requires a headend remodulator.
- Bus Network** A Local Area Network in which there is only one path between any two data stations and in which data transmitted by any station is available to all other stations connected to the same transmission medium. NOTE: A bus network may be linear, star, or tree topology.
- Byte** A group of bits, typically 8 bits, operated on as a single unit. A single alpha-numeric character typically occupies one byte. (See Octet).
- Cancel Service** MMS communication service which allows an application to cause the orderly termination of a service that is pending execution.
- Carrierband LAN** The form of baseband LAN used by IEEE 802.4.
- Carrier Sense** In a Local Area Network, an ongoing activity of a data station to detect whether another station is transmitting.
- Carrier Sense Multiple Access with Collision Detection (CSMA/CD)** A bus network in which the medium access control protocol requires carrier sense and in which exception conditions caused by collision are resolved by retransmission.
- Collision** A condition that results from concurrent transmissions on the transmission medium.
- Collision Domain** A single CSMA/CD network. If two or more MACs are within the same collision domain and both transmit at the same time, a collision will occur. MACs separated by a repeater are within the same collision domain. MACs separated by a bridge are within different collision domains.
- Command Dictionary** Provides an alphabetical listing of the LAN Interface commands.
- Command Field** That part of a protocol data unit (PDU) that contains commands, as opposed to the address field and information field.

- Common Name** A unique ASCII string of up to 64 characters used to describe an application process.
- Configuration File** Communications configuration information retained on disk at the GSM for each LAN Interface in the network. The configuration file is loaded into the LAN Interface together with the LAN Interface executive software.
- Confirmation** In the OSI Reference Model, one of four primitive types of interchange between entities of adjacent layers. A Configuration is returned to the higher layer upon completion of a requested service.
- Connection** A logical communication link established between two end points and used to transfer information.
- Connectionless Service** A protocol in which peer entities can communicate without first setting up a logical connection.
- Connection-Oriented Service** The set of services by which peer entities establish, use and terminate connections with one another. MMS applications are able to transfer information only after establishing a logical connection.
- CSMA/CD** See Carrier Sense Multiple Access with Collision Detection
- Data Communications Equipment (DCE)** Examples: Modems and transceivers. Distinct from DTE, Data Terminal Equipment.
- Data Link Layer** In Open Systems Interconnection architecture, the layer (Layer 2) that provides services to transfer data over a physical link between open systems. Consists of the LLC and MAC sublayers.
- Directory Information Base (DIB)** A table that holds the addressing information of the remote stations which the local application may initiate communications with. The DIB performs the same function as a telephone book.
- Directory User Agent (DUA)** A component of the application layer (Layer 7) that manages addressing information for other application layer components.
- DIS** ISO "Draft International Standard". In the case of MMS (ISO 9506), distinguished from IS. For ISO standards, this represents the stage just preceding a final standard.
- Distributed Directory Protocol** A proprietary protocol used to identify Ethernet Interfaces on a network that are able to communicate using the SRTP protocol. Used by Logicmaster 90 to locate Series 90 PLCs on the Ethernet network.
- Domain** In the Manufacturing Message Specification (MMS) the domain objects represent a subset of capabilities which can be used for a specific purpose. One of the key aspects of domains is that they can be uploaded and downloaded in the network. In the Series 15 CNC, domain content is associated with parts of the CNC memory or with Part Programs.
- Drop Cable** The cable that connects a data station to a trunk coupling unit.
- Data Terminal Equipment** Examples: computers, terminals, printers. Distinct from DCE, Data Communications Equipment.
- Entity** A single source or destination on the Local Area Network (LAN) in which data is transmitted and received.

- Ethernet Interface** The general term used in this manual to identify the GENet hardware module, with or without software, that connects a PLC or CNC to a network. In general, the network might be either Ethernet (802.3) or MAP (802.4). (See also “LAN Interface”)
- Executive Window** A part of the PLC scan that provides an opportunity for the LAN Interface to read and write PLC memory. The window is executed automatically once per PLC scan.
- Forward Channel** In a broadband LAN, the channel assigned for data transmission from the headend to the data stations.
- Frame** A data structure that consists of fields, predetermined by a protocol, for the transmission of user data and control data.
- Gateway** A functional unit that connects a Local Area Network to another network using different protocols.
- GENet** A trademark of GE Fanuc Automation, used to designate members of a family of hardware and software products that connect GE Fanuc PLCs and CNCs to industry-standard Local Area Networks, specifically, IEEE 802.3 (Ethernet) and IEEE 802.4 (MAP) networks.
- GENet System Manager (GSM)** A personal computer executing GSM software. The GSM is used to create and modify configuration information, and to load software and configuration information to each GENet LAN Interface. The GSM may communicate with the LAN Interface through a local serial-port connection to the LAN Interface or across the network (when a suitable PC network interface is installed).
- Global Address Administration** Address administration in which all LAN individual addresses are unique within the same or other Local Area Networks. (See also, “Local Address Administration”).
- Group Address** An LLC address that identifies a group of data stations on a Local Area Network.
- GSM** See GENet System Manager.
- Hands-off Service** A mode of application of a GENet LAN Interface that provides basic association, read and write functionality without the need for user programming. Uses the Responder Application Process.
- Hands-on Service** A mode of application of a GENet LAN Interface that provides greater control in the handling of associations, and focuses on the user’s application program in the associated PLC (relay ladder diagram) or CNC (PMC). Uses the Application Interface Application Process.
- Headend** In a broadband LAN, a device that received signals from each data station and retransmits them to all data stations.
- NOTE: The retransmission may require a shift of carrier frequencies.
- Host** Refers to a remote computer that communicates with a PLC or CNC on a network.
- IEEE 802** The IEEE 802 LAN series of standards are as follows:
- IEEE 802** Overview and Architecture.

- IEEE 802.2** The Logical Link Control (LLC) sublayer of OSI Data Link Layer common above all IEEE 802 Medium Access Control (MAC) sublayers.
- IEEE 802.3** CSMA/CD(Ethernet) MAC and Physical Layer standard.
- IEEE 802.4** Token Bus (MAP LANs) MAC and Physical Layer standard.
- IEEE 802.5** Token Ring (IBM) MAC and Physical Layer standard.
- Identify Services** Used to interrogate the identity of a remote application.
- Indication** In the OSI Reference Model, one of four primitive types of interchange between entities of adjacent layers. An Indication is initiated by the lower layer to advise of the activation of a particular service.
- Individual Address** An LLC address that identifies a particular data station on a Local Area Network.
- Information Field** That part of a protocol data unit (PDU) that contains data, as opposed to the address field and command field.
- Initiating Station** The station from which an instance of communication (a transaction) originates.
- Inter Repeater Link (IRL)** A mechanism for interconnecting two and only two repeater units.
- Invoke ID** A number which uniquely identifies an outstanding (ie, not yet confirmed) MMS request on a particular association..
- IS** ISO “International Standard”. In the case of MMS (ISO 9506), distinguished from DIS. For ISO standards, this represents the final version of a standard.
- ISO Standards** The International Organization for Standardization.
- Jabber** A transmission by a data station beyond the time interval allowed by the protocol.
- LAN Interface** A term used in this manual to identify the GENet hardware module, with or without software, that connects a PLC or CNC to a network. Reserved for cases where the authors wish to be explicitly inclusive of both Ethernet (802.3) and MAP (802.4) types. See also “Ethernet Interface.”.
- Layer** One of the seven layers of the Open Systems Interconnection (OSI) reference model. Each layer provides a set of hierarchically related services to the layer above.
- Linear Topology** A network topology in which stations are each connected at a point along a common continuous cable which has no loops and only two endpoints.
- Link Service Access Point (LSAP)** A Data Link layer SAP. A single octet that identifies the routing of data received by the station.
- Local Address Administration** Address administration in which all LAN individual addresses are unique within the same Local Area Network. (See also, “Global Address Administration”).
- Local Area Network (LAN)** A computer network located on a user’s premises within a limited geographical area.
- Local Station** The station at your immediate location, i.e., “here”. (See also “Remote Station”).

- Log Events** System exception log for the LAN Interface. The maximum number of events in the exception log is 16.
- Logical Link Control (LLC) Protocol** In a Local Area Network, the protocol that governs the exchange of frames between data stations independently of how the transmission medium is shared.
- Logical Ring** The abstract representation of a token-bus network, that is passing a token between data stations in a manner that simulates the passing of control in a ring network.
- MAC Address** The Medium Access Control (MAC) address is a 12-digit hexadecimal number that identifies a station on a network. Each LAN Interface has its own unique MAC address.
- Manufacturing Automation Protocol (MAP)** MAP communication protocol is specified by the Manufacturing Automation Protocol (MAP) specification. MAP is a “Connection-oriented” protocol; that is, stations residing on a network are able to transfer information only after establishing a logical connection much like two people using the telephone system.
- Manufacturing Message Specification (MMS)** A message format (or language), specified in internationally recognized standards which details how application information is transferred.
- MAP DIB** MAP Directory Information Base – (See also “ApplicationDIB”)
- MAP Directory Information Base (MAP DIB)** Each MAP station has a MAP DIB which is a directory of all application Processes with which the station will initiate MAP communications. See also Application Directory Information Base.
- MAP Interface** A GENet MAP 3.0 LAN controller board with associated modem. (See also “LAN Interface”). Distinct from MMS-Ethernet.
- Medium Access Control (MAC)** In a local area network (LAN), the part of the protocol that governs access to the transmission medium independently of the physical characteristics of the medium, but taking into account the topological aspects of the network, in order to enable the exchange of data between data stations.
- miniMAP** A simplified version of MAP. To achieve faster performance, miniMAP passes MMS messages directly over a Type III Link Layer, bypassing OSI layers 3-7 (Network through Application). The GENet MAP Interface supports miniMAP operation as specified in the MAP 3.0 specification. miniMAP is available only on an 802.4 network.
- miniMAP Application DIB (Directory Information Base)** A directory of 3-Layer miniMAP Application Processes which supplies all addressing information needed to communicate with each 3-Layer miniMAP Application Process. The GSM maintains a 3-Layer miniMAP Application DIB containing the miniMAP Application Processes defined by each configured station. Each MAP 3.0 station contains a Local miniMAP Application DIB which defines those miniMAP Application Processes with which the station will initiate miniMAP communications.
- Medium Access Control Protocol** In a Local Area Network, the protocol that governs access to the transmission medium, taking into account the topological aspects of the network, to enable the exchange of data between data stations.

- Medium Attachment Unit (MAU)** In a data station on a Local Area Network, a device used to couple the data terminal equipment to the transmission medium. Often called “transceiver”.
- MMS-Ethernet Interface** A term used in this manual to identify a GENet Ethernet Interface loaded specifically with MMS software.
- Multicast Address** A LAN group address that identifies a subset of the data stations on a Local Area Network.
- Network** An arrangement of nodes and interconnecting branches.
- Network Layer** Layer 3 of the OSI Model. This layer controls the flow of messages between nodes and performs the following services: message addressing, path set-up between nodes, and message routing.
- Network Driver Interface Specification (NDIS)** A multi-vendor specification defining a common interface to the PC network card and application programs running on the PC (such as the GSM or Logicmaster 90-70-Ethernet).
- Network Management Agent (NMA)** A component of the application layer (Layer 7) that performs local station management functions as directed by a Network Manager.
- Network Service Access Point (NSAP)** A set of octets which uniquely identify a particular station within a particular network.
- Node** The physical module that connects a station to the network. The Ethernet Interface is an example of a node. It connects a station (PLC or CNC) to a network (Factory LAN).
- Numeric Address** An absolute address of data as it is mapped into the physical devices (PLC or CNC) memory.
- Octet** A group of 8 bits operated on as a single unit. (See also “Byte”.)
- One-Way Propagation Time** See Transmission Path Delay.
- Open System Interconnection (OSI)** Defines international standards for communication systems development and implementation. Refer to Appendix B(Figure B.1) OSI Reference Model developed by (ISO). Defines a hierarchy of seven layers of communication protocol.
- Open System Interconnection(OSI) Reference Model** An international standard for network architecture which defines a seven layer model. The intent is to provide a network design framework to allow equipment from different vendors to be able to communicate. (Reference Appendix B)
- Path** The sequence of segments and repeaters providing the connectivity between two DTE's. In CSMA/CD networks, there is one and only one path between any two DTE's.
- Peer** Another entity at the same level (layer) in the communication hierarchy.
- Peer-Peer** Communication between stations at the same level or layer in the hierarchy.
- Physical Address** The unique address associated with a particular station on the Local Area Network (LAN).
- Physical Layer** Layer 1 of the OSI Model. This layer defines the electrical, mechanical, and timing aspects of the signal transmission over a medium.



**Presentation Layer** Layer 6 of the OSI Model. The Presentation Layer is concerned with data format.

**Program Invocation** The MMS Program Invocation objects are dynamic elements which can be thought of as executable portions of a task. Program Invocations have names which are used to identify them and internal states which describe what they are capable of doing.

**Protocol** A set of rules for exchanging messages between two communicating processes.

**Protocol Data Unit (PDU)** Information that is delivered as a unit between peer entities of a local area network (LAN) and that contains control information, address information, and may contain data.

**Read Services** Communication services used to obtain the values of variables from a remote application.

**Remote Station** Station located elsewhere on the network. (See also "Local Station")

**Repeater** In a Local Area Network, a device that amplifies and regenerates signals to extend the range of transmission between data stations or to interconnect two or more segments.

**Request** In the OSI Reference Model, one of four primitive types of interchange between entities of adjacent layers. A Request is initiated by the higher layer to activate a particular service.

**Responder** The Responder services respond to requests from remote application processes without further aid from the ladder logic program. (See also "Hands-Off Service")

**Responding Station** A station which generates a message in response to a command that was directed to the station.

**Response** In the OSI Reference Model, one of four primitive types of interchange between entities of adjacent layers. A Response is initiated by the higher layer in response to the Indication primitive.

**Response Window** In a token-bus network, a controlled interval of time, equal to one slot time, during which a data station, having transmitted a medium access control frame, pauses and listens for a response.

**Reverse Channel** In a broadband LAN, the channel assigned for data transmission from the data stations to the headend.

**Ring Topology** A network topology in which stations are connected serially in a closed loop.

**Round-Trip Propagation Time** Twice the time required for a bit to travel between the two most distant data stations in a bus network.

NOTE: In a network using carrier sense, each frame must be long enough so that a collision or jam signal may be detected by the transmitting station while this frame is being transmitted. Its minimum length is therefore determined by the round-trip propagation time.

**Router** A device similar to a bridge that allows access to multiple LANs. Routers require the first three Layers of the OSI Model.

**Scalar** An array or variable which has only one element.

**Segment** A continuous medium-“layer” connection between or among Medium Dependent Interfaces in a CSMA/CD LAN.

NOTE: Medium Dependent Interfaces connected by a repeater are on separate segments.

**Server** A data station that provides specific services to other data stations on a Local Area Network.

EXAMPLE: File server, print server, mail server.

**Service Access Point (SAP)** The access means by which a pair of entities in adjacent layers provide services.

**Service Request Transfer Protocol (SRTP)** A proprietary protocol that encodes Series 90 “Service Requests”, the native language of the Series 90 PLC CPUs, to provide general purpose communications with a Series 90 PLC. SRTP is presently available over 802.3/Ethernet networks. SRTP is also used by Logicmaster 90 to communicate over an Ethernet network.

**Session Layer** Layer 5 of the OSI Model. The Session Layer manages a logical connection (session) between two communicating processes or applications.

**Session Service Access Point (SSAP)** Octet string which uniquely defines each Session Layer user in a station.

**Signal Quality Error (SQE)** An indication from the MAU (transceiver) to the Ethernet Interface to indicate any of three conditions: 1) improper signals received from the medium, 2) collision detected, or 3) SQE message test.

**Slot Time (in a CSMA/CD network)** A bitrate-dependent unit of time which, in case of collision, is used to determine the delay after which data stations may attempt to retransmit. [Slot time for all IEEE 802.3 10 Mbps implementations is 51.2  $\mu$ sec (512 bit times)].

**Slot Time (in a Token-Bus network)** The maximum time any data station must wait for a response from another station. [It must be the same value on all stations of the LAN or the medium access control protocol may fail.]

**Soft Switches** Basic system information setup by the Logicmaster 90 Configurator and transferred to the LAN Interface upon powerup or restart.

**Star Topology** A network topology in which stations are each connected to a central hub via the station’s own (dedicated) link segment.

**Start Services** Communication services used to initiate control activity at a control device.

**Station** A computer, PLC, or other device that connects to a network.

**Station Address** Each station on the network must have a unique MAC address which is different from all other stations on the network. This is a 12-hexadecimal digit MAC address.

**Station Manager** A part of the basic LAN Interface communications software that executes as a background activity on the LAN Interface. The Station Manager provides interactive supervisory access to the LAN Interface module. The Station Manager may be accessed locally via the serial port, or remotely over the LAN.

**Stop Services** Communication services used to suspend control activity at a control device.

**Symbolic Address** Character string which symbolically represents a memory location in the PLC or CNC.

**Tally** Counters kept by the LAN Interface to indicate load and performance information.

**Token** In a token-passing Local Area Network, a specified group of bits serving as a symbol of authority passed successively from one data station to another to indicate the station temporarily in control of the transmission medium.

NOTE: All information is conveyed by frames. Some frames contain a token and no user data, others contain data and no token.

**Token Bus** A medium access control technique for a bus. The stations form a logical ring, around which a token is passed. When a station receives the token, it may transmit data. The station must then pass the token on to the next station in the logical ring.

**Token-Bus Network** A bus network in which a token passing protocol is used.

**Token-Ring Network** A ring network that allows unidirectional data transmission between data stations, by a token passing protocol, such that the transmitted data returns to the originating station.

**Token Passing Protocol/Procedure** In a Local Area Network using a token, the set of rules that governs how a data station acquires, uses, and transfers the token.

**Topology** The pattern formed by the physical medium interconnecting the nodes of a network..

**Transceiver** See Medium Attachment Unit (MAU).

**Transceiver Cable** See Attachment Unit Interface (AUI).

**Transmission Path Delay** The time required for a bit to travel between the two most distant data stations in a bus network.

**Transport Layer** Layer 4 of the OSI Model. The Transport Layer provides end-to-end control of a connection. This layer allows processes to exchange data reliably and sequentially.

**Transport Service Access Point (TSAP)** A Transport Layer SAP

**Tree Topology** A network topology that uses a cable emanating from a headend, with no closed circuits. Transmissions propagate throughout all branches of the tree, and are received by all stations.

**Trunk Cable** A cable connecting trunk coupling units for the purpose of allowing communication among data stations.

**Trunk Coupling Unit (TCU)** A physical device that connects a data station to a trunk cable by means of a drop cable.

NOTE: The trunk coupling unit contains the means for inserting the station into the network or bypassing it.

**Universal Address Administration** See Global Address Administration.

---

**Variable Name** A symbolic name which references a unique entry in a Variable Name Table. Used to simplify application programs and make them portable.

**Versa Module European (VME)** An electrical and mechanical bus specification based on Eurocard board size.

**Virtual Manufacturing Device (VMD)** A VMD is an abstract representation of a specific set of resources and functionality at the real manufacturing device, and a mapping of this abstract representation to the real manufacturing device.

**Word** A measurement of memory length, usually 4, 8, 16, or 32 bits long.

**Write Services** Communication services used to write information to a remote application.

# Appendix *B*

## *ISO Networking Concepts*

---

---

This appendix explains how communications takes place from the perspective of a GE Fanuc Automation control device in an OSI network. The discussion is based on the Manufacturing Message Specification (MMS) which details how application information is transferred from one application process to another. This discussion includes examples of how applications in GE Fanuc CNCs and Series 90–70 PLCs relate to the Application Layer of the International Standards Organization (ISO), Open System Interconnection (OSI) model.

Concepts introduced in this appendix are somewhat abstract since they are intended to describe a wide variety of communications. These concepts come from the Open System Interconnection (OSI) model and define terms which are used in configuring and managing the network and MMS Objects.

This appendix discusses:

- The OSI Reference Model
- OSI Addressing
- Protocol Data Transfer
- OSI Application Layer
- Locating Applications
- The Client–Server Model
- MMS Service Mapping
- MMS Objects and Their Attributes and States

### **Note**

It is not necessary to understand all of the material presented in this appendix in order to use LAN communication successfully. However, many terms and concepts used throughout this manual are described only in this section.



## Protocols Used for GE Fanuc Control Devices

The layers in the OSI model are abstract. They allow network architects to break down the issues in transferring data on networks into manageable parts. ISO has defined protocols to implement the functions at each layer. In GE Fanuc control devices, the ISO protocols used at each layer are listed in Table B-1 below.

**Table B-1. Protocol Used for GE Fanuc Control Devices**

<b>Layer</b>	<b>Protocol</b>	<b>Options</b>
MMS	ISO 9506	OIW agreements on operation with IS- and DIS-based systems (NIST 500-177 Chapter 20, Annex A).
ACSE	ISO 8649 ISO 8650	
Presentation	ISO 8822 ISO 8823	Kernel
Session	ISO 8326 ISO 8327	Kernel, Full Duplex Version 2
Transport	ISO 8072 ISO 8073	Class 4
Network	ISO 8473 ISO 8474/ Add. 1 ISO 9542	
Link LLC MAC	ISO 8802-2 ISO 8802-3	Type 1
Physical	ISO 8802-3	AUI, 10 Mbps baseband or broadband

## Implementation of the OSI Model in GE Fanuc Control Devices

In GE Fanuc control devices, each OSI layer is implemented as one or more *tasks*. These *tasks* implement the protocols defined for the layers of the OSI model. Figure B-2 shows the relationship among the tasks in a GE Fanuc device and layers of the OSI model.

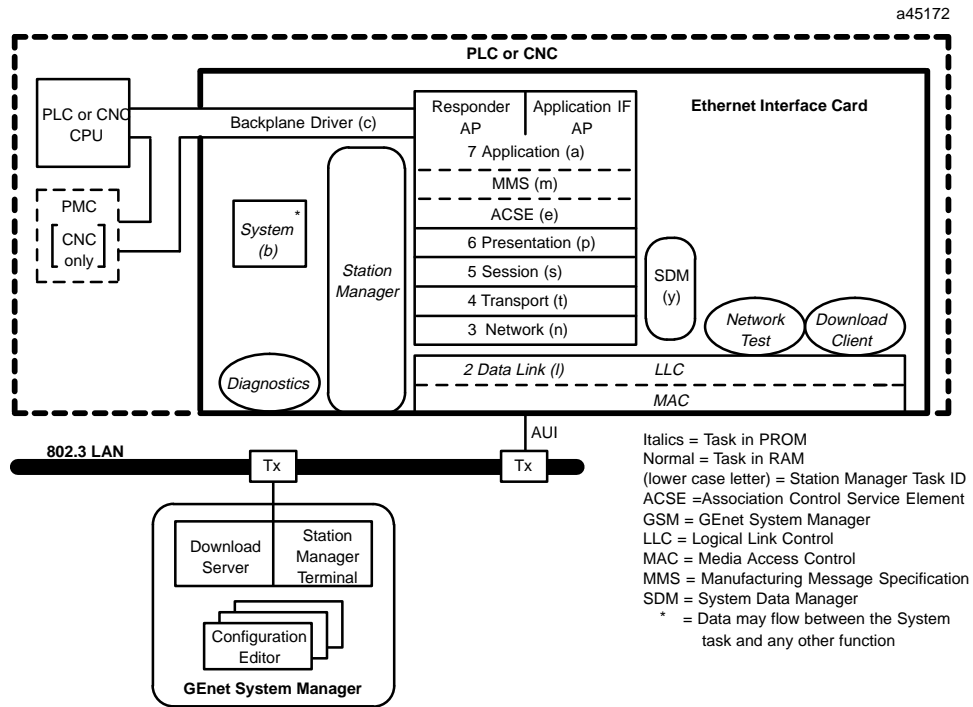

Figure B-2. Relationship between Tasks and Layers of GE Fanuc Control Devices

## Mapping MMS Services to ACSE and Presentation Services

The primary application interface between a user and a GEnet Interface is via MMS services. The MMS services map into ACSE and Presentation services as shown in the table below. These services are used to control the establishment and the release of an ACSE Association and data transfer over this association.

Table B-2. MMS Service Mapping to ACSE and Presentation Services

ACSE and Presentation Services	MMS Services
A-Associate	Initiate
P-Data and A-Release	Conclude
A-Abort	Abort
P-Data	All other services



# OSI Addressing

At each OSI layer, there is something (usually hardware, software, or a combination of the two) that implements the protocols for that layer. This entity is referred to as the *provider* of the layer service. For example, the network layer provider software implements the ISO network layer protocols.

Each layer may also have one or more *users* of the services provided by the layer. For example, the ISO transport provider is a network layer user.

In the OSI model, each layer is a user of the layer below it.

A OSI layer provider may have more than one user. To distinguish an individual user, OSI uses the term, *Service Access Point*, or SAP. The SAP is simply the point at which a user can access the service of a layer provider. Each layer SAP has a selector that distinguishes it. This selector is also referred to as a SAP address since it is used to address the desired user.

In some sense, each layer SAP provides a socket into which a layer user can be plugged. Figure B-3 illustrates how SAPs are used in GE Fanuc control devices to select the OSI protocols to be used.

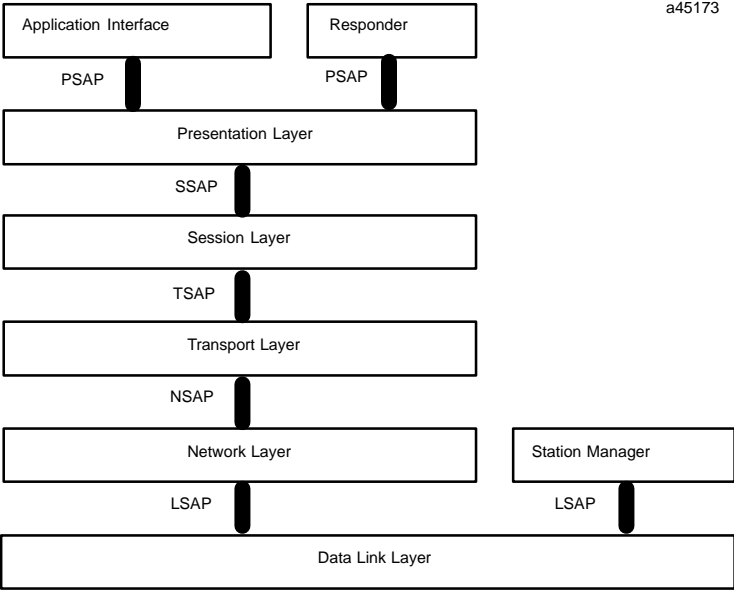

**Figure B-3. Service Access Points for the OSI Layers**

To address a protocol provider, it is necessary to provide the SAP selectors for all of the layers below it. For example, the session layer is addressed by a unique LSAP, NSAP, and TSAP sequence.

## Protocol Data Transfer

Data passed down the protocol stack is referred to as a Protocol Data Unit (PDU). As shown in Figure B-4, the (N+1) Layer passes the (N+1) PDU down to the (N) Layer. Once the PDU from the layer above is received, it is referred to as a Service Data Unit (SDU). The (N) Layer, again referring to Figure B-4, attaches Protocol Control Information (PCI) to the beginning and/or end of the (N) SDU in order to form the (N) Layer Protocol Data Unit (PDU). Then the (N) Layer PDU is passed on to the (N-1) Layer.

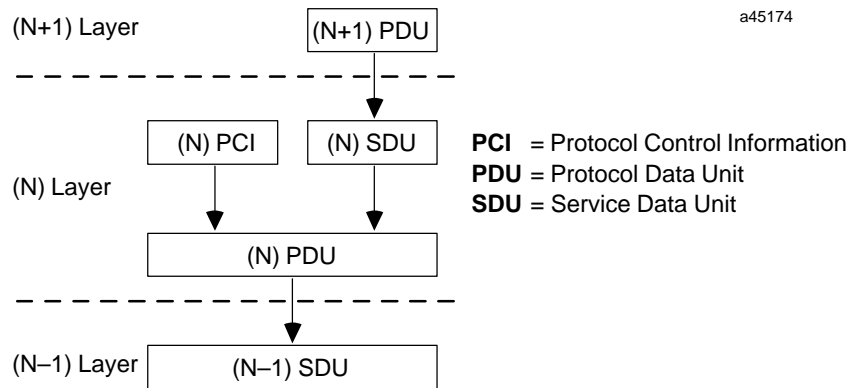

Figure B-4. Attachment of Protocol Control Information to form the Protocol Data Unit

This approach leads to a series of headers that are attached to the data on the sending side and stripped from the data at the receiving side, as shown in Figure B-5.

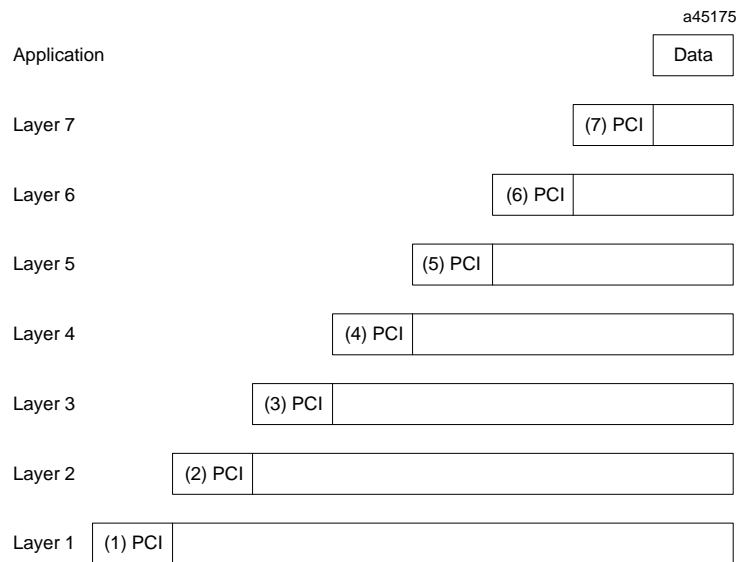

Figure B-5. Attachment of Protocol Control Information throughout the ISO Stack

## OSI Application Layer

When the OSI model is implemented (in hardware, software, or otherwise) using protocols that fit the model, the implementation is termed a *real open system*. Each process identified in a real open system, that performs information processing, is called an *Application Process* (AP).

### Application Process

A given Application Process may have many communication requirements and therefore may require many different types of communication services.

In the *Series 90–70 PLC* there are two separate Application Processes:

- The MMS Responder Application Process.
- The Application Interface Application Process

In the *CNC*, there are also two separate Application Processes:

- The CNC Responder Application Process
- The PMC Application Process (requires C language).

For GE Fanuc devices, there are separate Application Processes since their information processing functions are different.

### Application Entities

Those parts of the Application Process that process a particular set of OSI communication services are known as *Application Entities* (AEs). Each AE is uniquely addressable in the network. This address consists of an AE title, an AE qualifier, a Presentation Address, and an Application Context Name (ACN). It is the function of the Application Layer directory service to map from the *Application Common Name* (which describes the application) and ACN to the application address.

### Application Service Elements

Associated with each AE are one or more *Application Service Elements* (ASEs) such as the Association Control Service Element (ACSE). An ASE is that part of the AE that provides an OSI environment capability.

### User Elements

The part of the AP which uses the ASEs of one or more AEs is known as a *User Element* (UE). The UE is part of the AE and is the initiator of requests and responses and the recipient of indications and confirms from other applications. Thus there are two UEs in the Series 90–70 PLC -- the Application Interface UE, and the MMS Responder UE. And there are two UEs in the CNC -- the CNC UE and the PMC UE.

In GE Fanuc control devices, the purpose of the UEs is to transfer MMS service requests to peer applications in the network to control some manufacturing process. The following figure illustrates the general relationship between the parts of the OSI Application process.

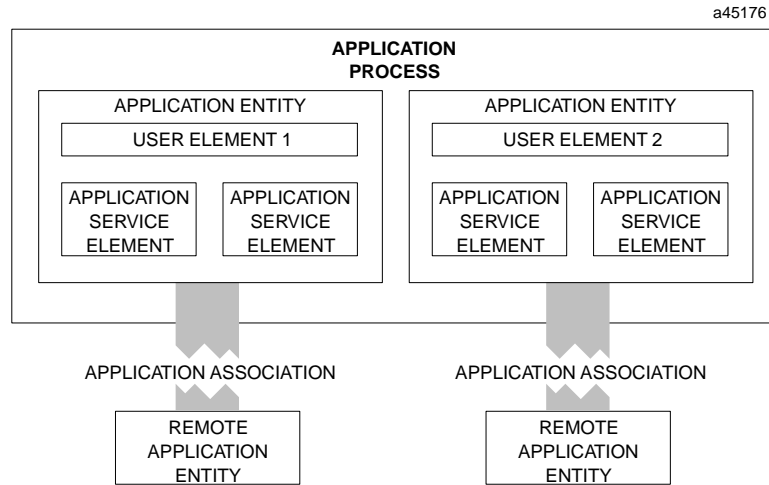

Figure B-6. Application Process Concept

### Series 90-70 PLC AP Implementation

The next figure illustrates how the Series 90-70 PLC looks as part of the OSI Application Process (AP).

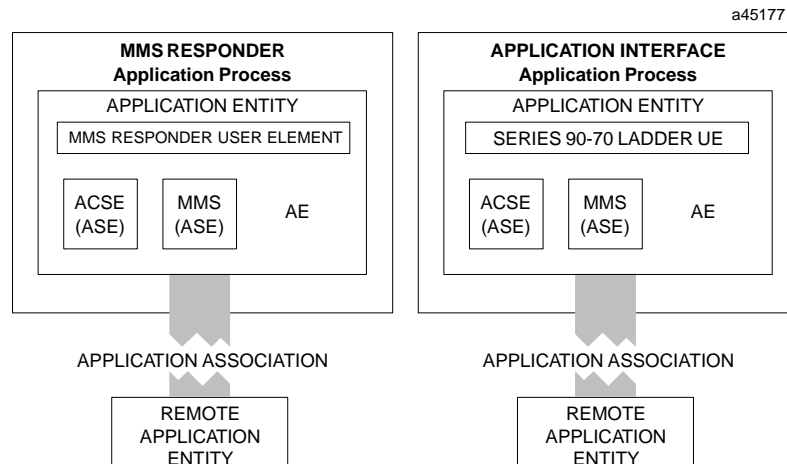

Figure B-7. Series 90-70 PLC Application Process Implementation

## GE Fanuc CNC AP Implementation

The next figure illustrates how the CNC looks as part of the OSI Application Process (AP).

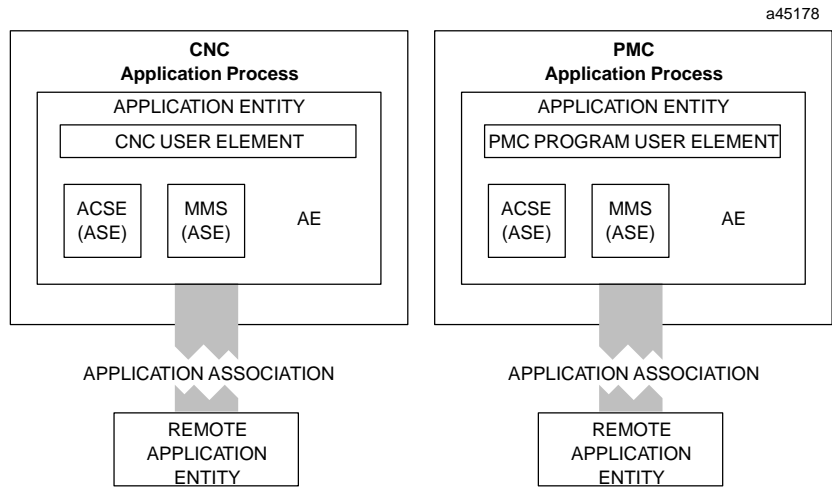

Figure B-8. CNC Application Process Implementation

## Locating Applications

Applications are identified by an *Application Common Name* which resolves into an address where the application resides. The common name is a string of characters which contains human readable text. The address associated with this name consists of a set of entries which are mostly interpreted as strings of bits and are more obscure for the human reader. These strings of bits represent the address information for each OSI protocol in order to reach the destination application. Many of these addresses are Service Access Point (SAP) selectors which identify how the information is to be routed through the layers to the proper layer entity above.

In the upper protocol layer, there are also items called object identifiers which are used to specify an object in the OSI environment. Objects are located in a hierarchical tree and are unambiguously identified by a path between nodes in this tree. Figure B-9 shows a typical object identifier and its place in the object space. The path to locate this object is denoted {2 1 1}.

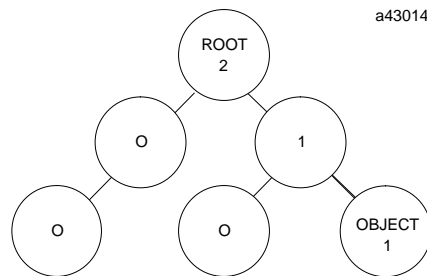

Figure B-9. MMS Object Identifier

The OSI directory service is used to resolve a common name to all required address information to locate that application. If you are using a directory server, the only address which must be present in the GE Fanuc control device configuration is the address of the directory server. In addition to, or in place of, a directory server, it is possible to preconfigure the addresses of some remote applications into each device configuration. The efficiency of using such statically configured information must be balanced against the complexity of managing directory information in each node rather than centrally when a directory server is used.

## The Client-Server Model

Application communication in the OSI model is peer-to-peer in the sense that there is no controlling master station polling information from slave devices. Either peer in the association can initiate communication requests. Since the processing requirements are different for the application initiating the communication and the application receiving the communication request, a method known as the *client/server model* is used to describe each communication exchange.

In the *client-server model*, the application which initiates a request for service is called the *client* (the client generates requests). The application from which the service is requested is called the *server* (the server generates responses).

The MMS services are, for the most part, *acknowledged services*. In an acknowledged service, the client issues a request for some service from the server application. When the service has been completed, either by performing the service or determining that the service cannot be performed, a confirmation message is returned to the client giving the results of the service request. The service is considered complete only when the confirmation is received. From the standpoint of the server application, service requests are begun when an indication arrives that the service is desired. After performing the service, the server issues a response to the client to provide the results of processing the indication.

The time sequence of MMS processing is shown in the following figure, where xxx is used to denote an arbitrary MMS acknowledged service.

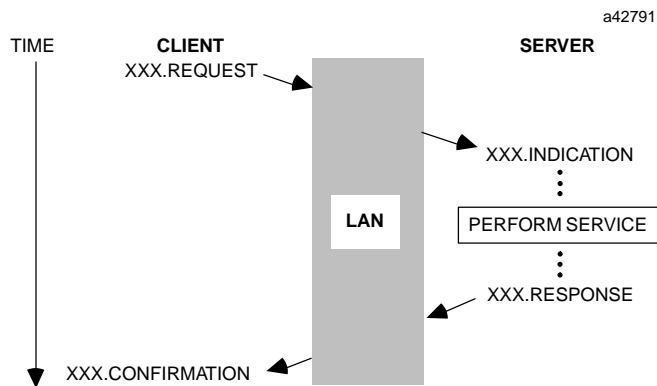

**Figure B-10. Acknowledged MMS Service**

Some MMS services are unacknowledged. In these services, only the request and indication parts of the figure are present. The MMS Unsolicited Status and Information Report services are examples of unconfirmed services.

Responses and confirms can be of two kinds: successful completion of the requested service, or an error. These two services are often denoted response (+) and response (-) respectively. Positive responses contain any results of performing the service. For a request that asks for a list of defined names, the positive response contains the list of names. For some requests, the positive response contains no data except the fact that the requested service was completed successfully. Negative responses include codes to specify why the requested service could not be completed.

In the discussion which follows, it is sometimes necessary to distinguish between the software which requests MMS services, called the *MMS User*, and the software which actually encodes the MMS Services and enforces the MMS protocol, called the *MMS Provider*.

## MMS Objects and Their Attributes

The Manufacturing Message Specification (MMS) defines a standard set of services in each manufacturing device implementing MMS. These services are used to access parts of the manufacturing device. Each part is known as an *object*. The MMS services and objects work together to present a standard view of all manufacturing devices to the network. By using MMS services, an MMS application can change the state of a peer MMS application in clearly defined and predictable ways. Details of how MMS objects interact are described below.

## Object Scope

Each object in MMS has an associated scope. The scope of a name is the range of visibility of the name. MMS defines three scopes: VMD wide scope, domain wide scope, and Application Association wide scope. A name with a VMD wide (or VMD specific) scope can be seen by all objects in the VMD. It exists for as long as the VMD exists. A name with a domain wide (or domain specific) scope can be seen by all objects in a domain but not by objects outside the domain. It exists for as long as the domain that contains it exists and ceases to exist when its containing domain is destroyed.

Similarly, a name with an Application Association wide (or AA specific) scope can be seen by all objects defined on that association. It exists for as long as the defining association exists and is destroyed when the defining association is destroyed. Each object reference in MMS includes the scope in which the name should be sought. This allows scope information to become part of resolving the name so that identical names in different scopes can be unambiguously accessed. Objects of the same kind in the same scope must have different names in order to be accessible.

## The Virtual Manufacturing Device (VMD) Object

The Manufacturing Message Specification (MMS) defines a standard view of all manufacturing devices, that is, how these devices are seen from other devices on the network. This standard behavior must be implemented in each real manufacturing device in order for useful MMS communication to take place. The MMS view of the manufacturing device is expressed in terms of a hierarchy of *objects*. Objects are simply parts of the manufacturing device which have attributes which can be seen from the outside. The internal representation of an object is of no importance so long as the object attributes reflect accurately the behavior defined by MMS. This separates the standard behavior of the device from implementation concerns while allowing a precise definition of its required behavior.

MMS communication takes place between Virtual Manufacturing Devices (VMDs). The VMD object is an abstraction used by MMS to describe the standard behavior of a real device (or a part of a real device). The MMS VMD and its associated real manufacturing device are closely associated but not identical. Since the VMD is only concerned with the MMS communication aspects of the real manufacturing device, changes in the real device which are not visible by MMS communication have no significance to the VMD.

### VMD Attributes

Each MMS object, including the VMD, has attributes. The attributes of an object are the distinguishable parts of the object when viewed from outside, making the services of MMS. Some of the attributes of a VMD are the vendor name, the model name, and the revision of the VMD executive function. The following figure shows the attributes of an MMS VMD.



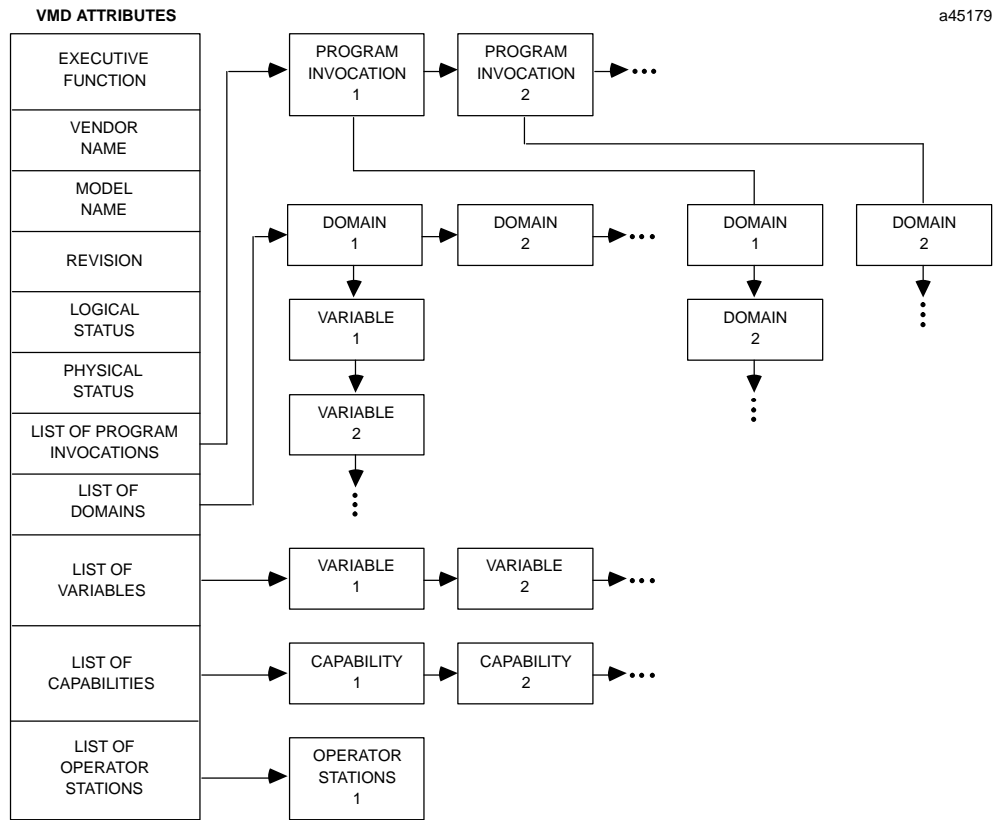

a45179

**Figure B-11. MMS VMD Attributes and Contained Objects**

As can be seen from this figure, MMS objects can have attributes which consist of lists of other MMS objects. These lists form a hierarchy of objects which as a whole form the MMS VMD. The MMS objects called *Capabilities*, *ProgramInvocations*, *Domains*, *Variable Accesses*, and *Operator Stations* are described below.

## VMD Status Attributes

The VMD has two attributes which describe the overall status of the VMD, the *Logical Status* attribute and the *Physical Status* attribute. The Logical Status attribute specifies the range of MMS services available at the VMD. The Physical Status attribute specifies the overall operational state of the real device (hardware) implementing the VMD. (Note that this status is unrelated to the ability of the device to communicate on the OSI network.)

### Series 90-70 PLC Only

Possible values of the VMD Logical Status attribute are: STATE-CHANGES-ALLOWED, NO-STATE-CHANGES-ALLOWED, LIMITED-SERVICES-PERMITTED, and SUPPORT-SERVICES-ALLOWED (ISO IS 9506 only). When the Logical Status has the value STATE-CHANGES-ALLOWED, all available MMS services for the device may be performed. When the Logical Status has the value NO-STATE-CHANGES-ALLOWED, only those MMS services which do not change the state of any MMS object can be used. These services for the Series 90-70 MMS Provider are:

- Abort
- Conclude
- Cancel
- Status
- GetNameList
- Identify
- GetCapabilityList
- GetDomainAttributes
- GetProgramInvocationAttributes
- GetVariableAccessAttributes
- Read

When the Logical Status has the value LIMITED-SERVICES-PERMITTED, the only MMS services which can be performed are Abort, Conclude, Status, and Identify. When the Logical Status has the value SUPPORT-SERVICES-ALLOWED (ISO IS 9506 only), all services are available *except* Start, Stop, Reset, and Resume.

Initially, the Series 90-70 MMS Provider sets the VMD Logical Status attribute to the value STATE-CHANGES-ALLOWED so long as the Ethernet Interface hardware can communicate to the Series 90-70 PLC and to LIMITED-SERVICES-PERMITTED, if no access to the Series 90-70 PLC is possible (refer to the discussion in Chapter 6 for the method used for communicating between the Ethernet Interface hardware and the Series 90-70 PLC). The Series 90-70 application has the ability to explicitly set the status values of the VMD based on its knowledge of the VMD using explicit application service requests.

Possible values of the VMD Physical Status are: OPERATIONAL, PARTIALLY-OPERATIONAL, INOPERABLE, and NEEDS-COMMISSIONING. Initially this status is set to OPERATIONAL by the Series 90-70 MMS Provider. The Series 90-70 ladder logic can set this status to any valid value based on its knowledge of the real device status.

## GE Fanuc CNCs Only

Possible values of the VMD Logical Status attribute are: STATE-CHANGES-ALLOWED, NO-STATE-CHANGES-ALLOWED, LIMITED-SERVICES-PERMITTED, and SUPPORT-SERVICES-ALLOWED. When the Logical Status has the value STATE-CHANGES-ALLOWED, all available MMS services for the device may be performed. When the Logical Status has the value NO-STATE-CHANGES-ALLOWED, only those MMS services that do not change the state of any MMS object can be used. When the Logical Status has the value LIMITED-SERVICES-PERMITTED, only a few essential services are allowed. When the Logical Status has the value SUPPORT-SERVICES-ALLOWED, all services other than those that alter the state of a PI are permitted. In Table B-2 in the section titled “VMD Logical State”, a “Y” denotes that the service is available in the specified Logical Status.

Table B-2 also shows how the CNC communication mode (Local or Remote) affects which services may be performed. (See Chapter 5 for a description of Local and Remote Communication Modes).

Possible values of the VMD Physical Status are: OPERATIONAL, PARTIALLY-OPERATIONAL, INOPERABLE, and NEEDS-COMMISSIONING. Under normal operating conditions, the Physical Status will be OPERATIONAL. When an alarm condition or E-Stop occurs, the Physical Status changes to INOPERABLE, until the alarm or E-Stop is cleared. If the OSI-Ethernet Interface cannot successfully communicate with the CNC main processor, the Physical Status is NEEDS\_COMMISSIONING.

**Table B-3. Effect of VMD Logical State and CNC Mode on MMS Services**

MMS Service	VMD Logical State				CNC Communications Mode	
	S-C-A	N-S-C-A	L-S-P	S-S-A	Local	Remote
Initiate	Y	Y	Y	Y	Y	Y
Conclude	Y	Y	Y	Y	Y	Y
Abort	Y	Y	Y	Y	Y	Y
Cancel	Y	Y		Y	Y	Y
UnsolicitedStatus	Y			Y	Y	Y
Status	Y	Y	Y	Y	Y	Y
GetNameList	Y	Y		Y	Y	Y
Identify	Y	Y	Y	Y	Y	Y
Read	Y	Y		Y	Y	Y
Write	Y			Y		Y
InformationReport	Y			Y	Y	Y
GetVariableAccessAttributes	Y	Y		Y	Y	Y
Input	Y			Y	Y	Y
Output	Y			Y	Y	Y
InitiateDownloadSequence	Y			Y	Y	Y
TerminateDownloadSequence	Y			Y	Y	Y
TerminateUploadSequence	Y			Y	Y	Y
RequestDomainDownload	Y			Y	Y	Y
DeleteDomain	Y			Y	Y	Y
GetDomainAttributes	Y	Y		Y	Y	Y
CreateProgramInvocation	Y			Y		Y
DeleteProgramInvocation	Y			Y		Y
Start	Y					Y
Stop	Y					Y
Resume	Y					Y
Reset	Y					Y
GetProgramInvocationAttributes	Y	Y		Y	Y	Y

S-C-A = STATE-CHANGES-ALLOWED  
 N-S-C-A = NO-STATE-CHANGES-ALLOWED  
 L-S-P = LIMITED-SERVICES-PERMITTED  
 S-S-A = SUPPORT-SERVICES-ALLOWED

## Capability Objects

A capability is a locally defined resource (either physical or logical) which can be identified by a name. Capabilities are not further constrained by MMS. Capabilities may be used to segment the functions of the VMD in some way meaningful to the application or to the process. For example: a capability “conveyor” could be defined for a conveyor, and a second capability “table” could be defined for an index table, in a Programmable Logic Controller (PLC) which was capable of controlling both devices. Capabilities may be shared or overlapped as needed.

There are two capabilities that have special meaning to the Series 90-70 Ethernet Interface: BASEADDR and HIGHADDR.

The BASEADDR capability has special meaning when it appears in the capability list of a domain which is being downloaded. This capability can be used to specify the beginning address at which the domain is to be loaded.

The form of the capability string is:

```
BASEADDR = %<symbolic address>
```

where <symbolic address> is a valid Series 90-70 PLC symbolic address from Chapter 6.

The HIGHADDR capability has special meaning when it appears in the capability list of the VMD (see Chapter 4, the Station Manager CAP command). It gives the highest configured value for each of the memory types Register (%R), Analog Input (%AI), and Analog Output (%AQ). This allows a remote device to determine the size of those Series 90-70 PLC memory tables by examining the VMDs capability list.

The HIGHADDR capability also has special meaning when it appears in the capability list of a domain that has been downloaded. This capability is used to specify the ending address of the domain. The form of the capability string is:

```
HIGHADDR = %<symbolic address>
```

In the CNC, no capabilities are supported or allowed.

## Domain Objects

MMS domain objects represent subsets of the VMD that can be used for a specific purpose. This purpose might for example be a specific manufacturing process. One of the key aspects of domains is that they can be uploaded and downloaded in the network. This allows the domain to be transferred between two communicating MMS applications. In VMDs having a file store, domain content is often closely associated with a file. In the Series 90-70 PLC, domains are not supported. In the CNC, a domain might be a part program or some memory area such as parameter storage or a tool offset table.

Like all MMS objects, domains have attributes. Attributes describe the distinguishable parts of the object. Constraints specify attributes which are only present under the specified circumstances. The attributes of the domain object are shown in the table below. Attributes which are present if the constraint is met are shown indented below the constraint.

**Table B-4. Domain Attributes**

Key Attribute:	Domain Name
Attribute:	List of Capabilities
Attribute:	State (LOADING, COMPLETE, INCOMPLETE, READY, IN-USE)
Constraint:	State = (LOADING, COMPLETE, INCOMPLETE)
Attribute:	AssignedApplicationAssociation
Attribute:	MMS Deletable (TRUE, FALSE)
Attribute:	Domain Content
Attribute:	List of Subordinate Objects
Constraint:	State = IN-USE
Attribute:	List of Program Invocation References
Attribute:	Upload in Progress

The domain name is used to identify the domain within the VMD. This allows MMS services to manipulate the domain object. Each domain represents a subset of capabilities in the VMD. These capabilities are associated with the domain as attributes. Domains have a state attribute which describes the readiness of the domain. Figure B-12, shows the possible states for the domain. In this and succeeding state diagrams, states are illustrated as boxes and transitions as arrows.

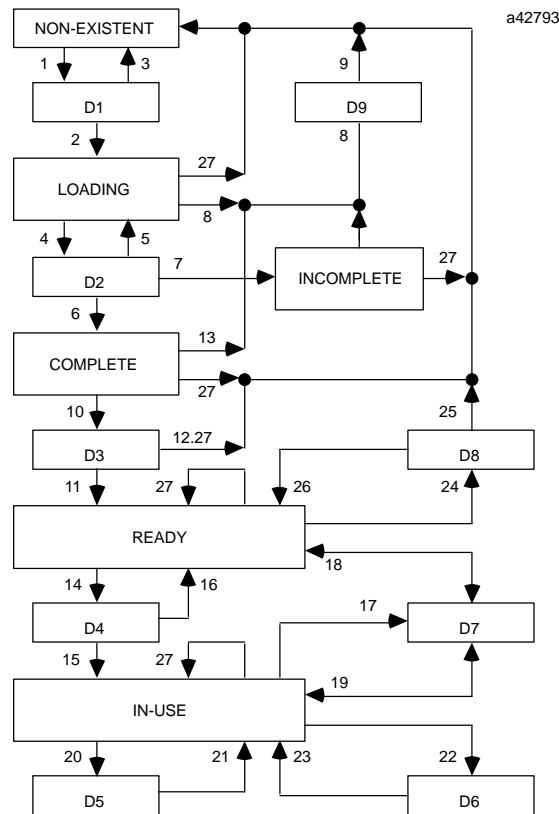

**Figure B-12. Domain State Diagram**

Transitions of the Domain State Diagram are as follows:

Line	Description	Line	Description
1	InitiateDownloadSequenceIndication	15	CreateProgramInvocation Response (+)
2	InitiateDownloadSequence Response (+)	16	CreateProgramInvocationResponse(-)
3	InitiateDownloadSequence Response(-)	17	DeleteProgramInvocationIndication Program Invocation Count = 0
4	DownloadSegmentRequest	18	DeleteProgramInvocation Response (+)
5	DownloadSegmentConfirm (+) More Follows = True	19	DeleteProgramInvocationResponse(-)
6	DownloadSegmentConfirm (+) More Follows = False	20	CreateProgramInvocationIndication Program Invocation Count > 0
7	DownloadSegmentConfirm (-)	21	CreateProgramInvocation Response (+) or (-)
8	TerminateDownloadSequenceRequest	22	DeleteProgramInvocationIndication Program Invocation Count > 1
9	TerminateDownloadSequenceConfirm (+) or (-)	23	DeleteProgramInvocation Response (+) or (-)
10	TerminateDownloadSequence Request Discard = False	24	DeleteDomainIndication
11	TerminateDownloadSequenceConfirm (+)	25	DeleteDomain Response (+)
12	TerminateDownloadSequenceConfirm (-)	26	DeleteDomain Response (-)
13	TerminateDownloadSequence Request Discard = True	27	AbortIndication
14	CreateProgramInvocation IndicationProgram Invocation Count = 0		

Prior to being created from the network or from some local action, the domain is in a NON-EXISTENT state. There is no object associated with this state and this state should never be reported for a domain object. Other intermediate states exist (e.g., COMPLETE and INCOMPLETE) which occur during download of a domain. Refer to the following table for intermediate and concluding domain states.

**Table B-5. Domain States**

<b>Domain</b>	<b>Definition</b>
NON-EXISTENT	The domain is in a NON-EXISTENT state and no object is associated with this state.
LOADING	The LOADING state is an intermediate state which occurs during the loading process.
READY	The domain enters a READY state when it is successfully downloaded or otherwise created.
COMPLETE	The COMPLETE state is entered when the domain has been successfully loaded but is not yet acknowledged as loaded and thereby READY.
INCOMPLETE	The INCOMPLETE state is entered if an error occurs during loading which will cause the domain to be discarded. If, for instance, the association which is being used to load the domain is lost during the download of the domain, the domain is discarded and passes through the INCOMPLETE state.
IN-USE	The IN-USE state is different from the READY state in that it indicates that one or more ProgramInvocations have been defined as using this domain. For example, a part program will be in the ready state if it is not the active part program and in the IN-USE state if it is active.

**Series 90-70 PLC Only**

The Series 90-70 PLC does not support domains.

**GE Fanuc CNCs Only**

The *MMS Deletable* attribute specifies whether this object can be deleted using the MMS Delete Domain service. The *Sharable* attribute specifies whether this domain can be used by more than one Program Invocation. Most GE Fanuc control devices do not allow any sharing of domains. CNCs supporting multiple tool paths allow limited sharing of domains. The *Upload in Progress* attribute specifies the number of uploads currently in progress for the domain.

The *Domain Content* attribute is the information contained in the domain as downloaded. Included in this content may be a list of subordinate objects, which are objects defined in the domain specific scope of this domain. Refer to the discussion of object scope earlier.

If the domain is IN-USE, it is associated with one or more ProgramInvocations. The list of ProgramInvocation references contains the ProgramInvocations which use this domain (if any). Since there is only one ProgramInvocation in most GE Fanuc control devices, this list will usually contain at most one ProgramInvocation.



## Program Invocation Objects

MMS Program Invocation objects are dynamic elements that can be thought of as executable tasks. For the CNC, there is a ProgramInvocation associated with each independent tool path. For a Series 90-70 PLC there is a single PI. In other manufacturing devices there may be one or more Program Invocations. MMS provides services to control the executing state of the Program Invocations and to create and destroy them. The attributes of the Program Invocation Objects are shown below:

**Table B-6. Program Invocation Attributes**

Key Attribute:	Program Invocation Name
Attribute:	State (IDLE, STARTING, RUNNING, STOPPING, STOPPED, RESUMING, RESTARTING, UNRUNNABLE)
Attribute:	List of Domain References
Attribute:	MMS Deletable (TRUE, FALSE)
Attribute:	Reusable (TRUE, FALSE)
Attribute:	Monitor (TRUE, FALSE)
Constraint:	Monitor = TRUE
Attribute:	Event Condition
Attribute:	Event Action
Attribute:	Event Enrollment
Attribute:	Execution Argument (Initially empty)
Attribute:	Additional Detail

ProgramInvocations have names which are used to identify them and internal states which describe what they are capable of doing. Figure B-13 shows the possible transition states for the Program Invocation.

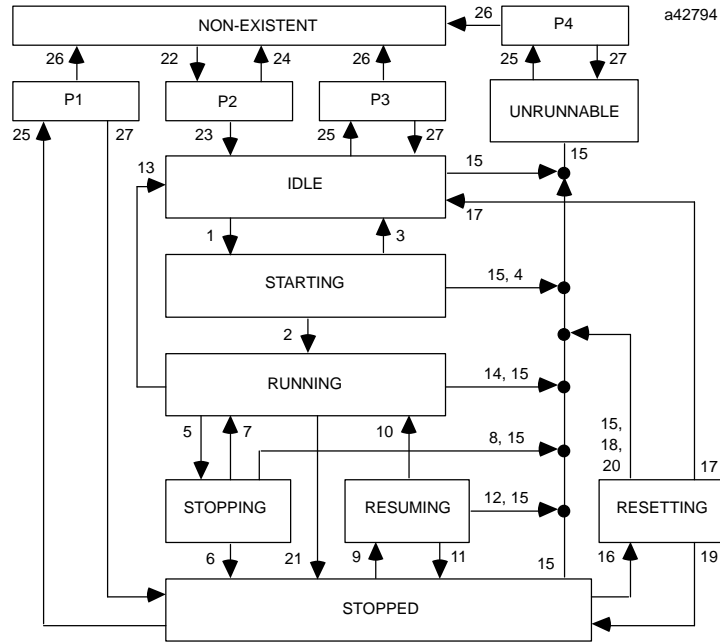

**Figure B-13. Program Invocation State Diagram (PI State)**

Transitions for the Program Invocation State (PI State) are as follows:

Line	Description	Line	Description
1	Start Indication	15	Kill Response (+)
2	Start Response (+)	16	Reset Indication
3	Start Response (-) non-destructive	17	Reset Response (+) Reusable = True
4	Start Response (-) destructive	18	Reset Response (+) Reusable = False
5	Stop Indication	19	Reset Response (-) Non-destructive
6	Stop Response (+)	20	Reset Response (-) Destructive
7	Stop Response (-) non-destructive	21	(Program Stop)
8	Stop Response (-) destructive	22	CreateProgramInvocation Indication
9	Resume Indication	23	CreateProgramInvocation Response (+)
10	Resume Response (+)	24	CreateProgramInvocation Response (-)
11	Resume Response (-) non-destructive	25	DeleteProgramInvocation Indication
12	Resume Response (-) destructive	26	DeleteProgramInvocation Response (+)
13	(End of Program) Reusable = True	27	DeleteProgramInvocation Response (-)
14	(End of Program) Reusable = False		

Table B-7. Program Invocation States

Program Invocation	Definition
IDLE	The IDLE state denotes the condition of a ProgramInvocation at a time before it is placed into operation.
RUNNING	The RUNNING state denotes the condition of a Program Invocation during its execution.
STOPPED	The STOPPED state denotes the condition of a Program Invocation in which execution has ceased and no changes are being made to the contents of the Program Invocations constituent domains.
UNRUNNABLE	The UNRUNNABLE state denotes a condition in which the Program Invocation can no longer be executed.
STARTING	The STARTING state is a transition state between IDLE and RUNNING.
STOPPING	The STOPPING state is a transition state between RUNNING and STOPPED.
RESUMING	The RESUMING state is a transition state between STOPPED and RUNNING.
RESETTING	The RESETTING state is a transition state between STOPPED and IDLE.

The *MMSDeletable* attribute specifies whether the ProgramInvocation can be deleted by the MMS DeleteProgramInvocation service. The *Reusable* attribute indicates whether or not the ProgramInvocation will return to the IDLE state after completing execution. Associated with each invocation of a ProgramInvocation is an argument string. This string is the *Execution Argument* attribute.

### Series 90-70 PLCs Only

The Series 90-70 application can use service requests to change the scope and the state of the ProgramInvocation. Unless changed explicitly by the application, the ProgramInvocation scope will be the entire PLC and its state will be: RUNNING while the Series 90-70 PLC is solving the relay ladder application and STOPPED while the Series 90-70 processor is set to a stopped position.

When the Ethernet Interface is restarted, it will automatically retrieve the name of the current Series 90-70 ladder logic program (same as the folder name defined by Logicmaster 90). The Ethernet Interface then uses that as the name for its Program Invocation object that is visible to the network. If there is no program in the PLC, or if the Ethernet Interface is unable to retrieve the program name from the CPU, the Program Invocation name is null.

### GE Fanuc CNCs Only

For the CNC, the PI state reflects the execution state of the part program associated with the PI. If the part program is running, the PI state is RUNNING. If a feed-hold is asserted, the PI state is stopped.

In a TT model control, there can be three Program Invocations. The “coordination PI” is created automatically during OSI-Ethernet initialization. There can be up to two PIs, one for each path for which a part program has been selected. A special domain, called the “coordination domain”, is used to synchronize MMS services to the two paths. The

coordination PI always contains the coordination domain. When a Program Invocation is created that contains the coordination domain in its list of domains, a special relationship is established between the coordination PI and the path PI(s). Issuing an MMS Start/Stop/Reset/Resume command to the coordination PI will result in the MMS service being automatically propagated to the path PI(s). This coordination PI represents a mechanism by which the host can alter the state of the two path PIs simultaneously with one MMS service.

## Variable Objects

MMS variable objects allow the remote MMS application to access typed data values defined in the VMD. A variable is an element in the VMD which is capable of providing (when read) or accepting (when written) a typed data value. A type specifies the range of possible values and the representation of the values for a variable. Variables are stored in various parts of the memory of the GE Fanuc control devices.

MMS allows variables to be accessed in two different ways: by variable name and by address. Variable names allow remote applications to access data in GE Fanuc control devices without having an intimate knowledge of where and how the data is represented in the memory of the device. Address access (also called unnamed access) allows the memory of the device to be directly accessed by applications that require such access. Access to variable data by address makes the client dependent on design choices in the server application and should be used carefully and sparingly. An example of a named variable is "production\_today" that is an integer giving a count of the day's production.

Like all MMS objects, variables have attributes. The attributes of named variables and unnamed variables are shown in the following table.

**Table B-8. Variable Access Attributes**

Unnamed Variable Object	
Key Attribute:	Address
Attribute:	MMS Deletable (FALSE)
Attribute:	Access Method (PUBLIC)
Attribute:	Type Description
Named Variable Object	
Key Attribute:	Variable Name
Attribute:	MMS Deletable (TRUE, FALSE)
Attribute:	Type Description
Attribute:	Access Method (PUBLIC, ...)
Constraint:	Access Method = PUBLIC
Attribute:	Address

The *Name* or *Address* attribute serves to identify the variable. The *MMSDeletable* attribute tells whether the variable may be removed using MMS services. The *type* gives the representation and range for the data. The valid types for GE Fanuc control devices are shown in the following table.

**Table B-9. GE Fanuc Control Device Data Types**

Type	Description
Boolean	A single binary value
Integer	A signed integer value
Unsigned	An unsigned integer value
Real	A signed floating point value
Bit String	A sequence of consecutive bits of arbitrary bit length
Octet String	A sequence of eight bit values of arbitrary length
Character String	A sequence of printable ASCII characters

### Operator Station Objects (CNC Only)

MMS Operator Station object represent a mechanism for displaying or entering (or both) information from an operator. The GE Fanuc CNC Operator Console is an example of an operator station capable of both input and output.

The attributes for an operator station are shown in the table below.

**Table B-10. Operator Station Attributes**

Key Attribute:	Operator Station Name
Attribute:	Station Type (ENTRY, DISPLAY, ENTRY-DISPLAY)
Constraint:	Station Type = Entry
Attribute:	Input Buffer
Attribute:	State (IDLE, WAITING-FOR-INPUT-STRING, INPUT-BUFFER-FILLED)
Constraint:	Station Type = DISPLAY
Attribute:	List of Output Buffer
Attribute:	State (IDLE, OUTPUT-BUFFERS-FILLED)
Constraint:	Station Type = ENTRY-DISPLAY
Attribute:	Input Buffer
Attribute:	List of Output Buffer
Attribute:	State (IDLE, DISPLAY-LIST-OF-PROMPT-DATA, WAITING-FOR-INPUT-STRING, INPUT-BUFFER-FILLED, OUTPUT-BUFFERS-FILLED)
Attribute:	Additional Detail

The Operator Station Name attribute serves to identify the operator station. The Station Type attribute indicates the abilities of the station. All CNC operator stations are of type ENTRY-DISPLAY.

The input buffer and lists of output buffer attributes contain the data input or displayed at the station. The state attribute changes based on the state transitions shown in Figure B-14.

There are no Operator Station objects for the Series 90-70 PLC.

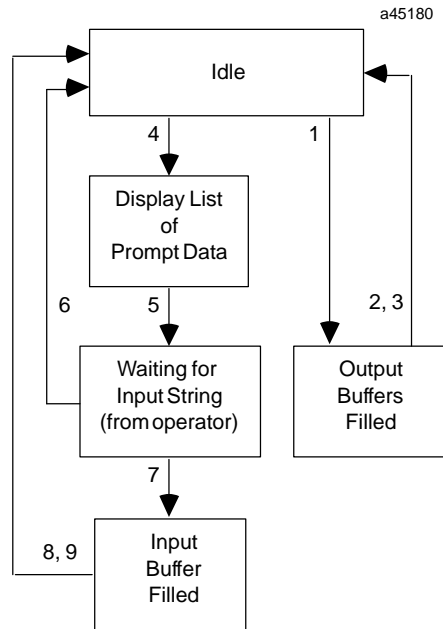

**Figure B-14. Operator Station State Diagram**

Transitions for the Operator Station State are as follows:

Line	Description
1	Output Indication
2	Output Response (+)
3	Output Response (-)
4	Input Indication
5	(D-Put function finished displaying List of Prompt Data, if any. If present, Input Time Out begins.)
6	Input Response (-) due to a time out
7	(E-Get function finished entering the Input String into input buffer. If present, Input Time Out stops.)
8	Input Response (+)
9	Input Response (-)

## MMS Variable Mapping (Series 90-70 PLC Only)

This section describes how the Manufacturing Message Specification (MMS) data types are represented in the Series 90-70 PLC memory.

MMS variables are bound directly to locations in the Series 90-70 PLC memory. Access to variables result in access to the corresponding locations in the Series 90-70 memory without requiring (or allowing) any intervention by the Series 90-70 ladder logic program.

Each variable in MMS has an associated type which describes the meaning of the bits that constitute the value of the variable. This appendix describes the correspondence between each MMS data type supported by the Series 90-70 PLC and its representation in memory.

Along with the type information, size information is needed to specify the memory limits of values. The size information for a type is specified in units appropriate to the type.

The table below summarizes the type and sizes supported by the Series 90-70 PLC.

**Table B-11. MMS Variable Types and Size**

Type	Encoding	Length Units	Minimum Length	Maximum Length
Boolean	3	bit	1	1
BitString	4	bit	1	1024
Signed Integer	5	bit	8	32
Unsigned Integer	6	bit	8	31
FloatingPoint	7	octets	4	4
Octet String	9	octets	1	4096
VisibleString	10	octets	1	4096

Arrays of any of the above types are supported. Arrays are limited to a single dimension (subscript).

### Boolean Data

Boolean Data is mapped to a single bit in the Series 90-70 PLC memory. Arrays of boolean values are mapped to contiguous bits within the Series 90-70 memory. Boolean data may begin at any bit offset within the memory word of the Series 90-70. Only those bits which have been mapped to the MMS variable will be modified on access to the memory word. All other bits will be unaffected.

Boolean Array Data is mapped into words in word memory in a way that facilitates the transfer of data between register and I/O memory. The first element of the boolean array (element 0) is placed in the Least Significant Bit (LSB) of the register memory assigned to the array. The second element is placed in the next most significant bit, and so on. If the bit offset defined for the array is zero, the elements are placed into the register as shown in the table below. When written to I/O memory, the first array element is placed in the lowest I/O location, the next higher element into the next higher I/O location, etc.

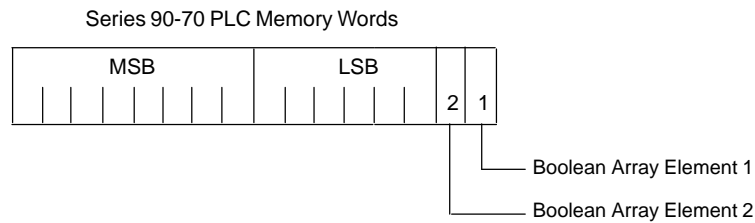

**Figure B-15. MMS Boolean Data Memory Mapping**

**Note**

The Series 90-70 CPU does not provide a Read-Modify-Write capability to the Ethernet Interface. As a result, bit-oriented data (such as Boolean and bit string) must be manipulated in memory which has a unit type of bit (see Chapter 6). That same data may be redefined in units of words or octets and transferred to memory that is not bit-oriented.

**Bit String Data**

Bit String Data is mapped to consecutive bits of Series 90-70 PLC memory exactly like arrays of boolean values. As with Boolean Data, only those bits in the word(s) of Series 90-70 memory which are required to contain the bit string data are modified or accessed. Arrays of bit strings are packed in such a way that the first bit at the second element immediately follows the last bit of the first element. For example, a two-element array of two-bit, bit strings (at bit offset 0 in a register) would be mapped as shown in the figure below.

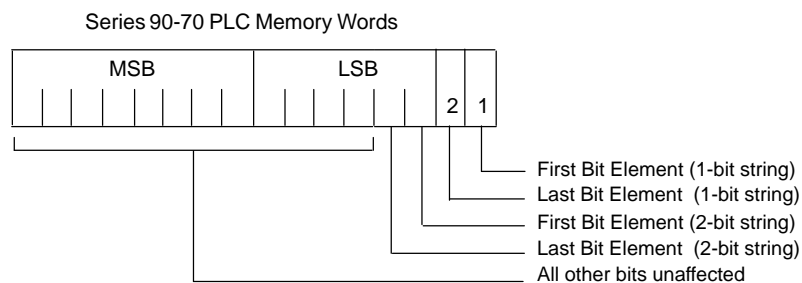

**Figure B-16. MMS Bit String Data Memory Mapping**

**Note**

The Series 90-70 CPU does not provide a Read-Modify-Write capability to the Ethernet Interface. As a result, bit-oriented data (such as Boolean and bit string) must be manipulated in memory which has a unit type of bit (see Chapter 6). That same data may be redefined in units of words or octets and transferred to memory that is not bit-oriented.



## Signed and Unsigned Integers

Signed and Unsigned Integers can be defined in Series 90-70 PLC memory as 8-bit or 16-bit quantities. Signed Integers of 32 bits or Unsigned Integers of 31 bits are also supported. Integers and arrays of integers must begin on a word boundary (i.e., they must have a bit offset of zero).

Array elements use an integral number of words. Thus, for arrays of 8-bit integers in register memory, each element occupies an entire register. Bits in memory which exceed the type size are ignored for transfer to the network and are set to zero when written by the Ethernet Interface software.

## Floating Point

Single precision (4-octet) Floating Point Values are transferred between the network and Series 90-70 PLC memory in the form required by the Series 90-70 for floating point operation. Floating point values *always* occupy 4 octet (2 words). They must begin on a word boundary (i.e., the bit offset must be zero).

## Octet Strings and Visible Strings

Octet Strings and Visible Strings are mapped to consecutive octets in Series 90-70 PLC memory. In word memory, the first octet (of an octet string) resides in the least significant byte of the word while the second octet resides in the most significant byte. Thus strings must be “byte swapped” if entered as numeric data. Strings must begin on a word boundary (i.e., the bit offset must be zero). String arrays may have an element size which is odd. Only those octets which comprise an array element are accessed when indexing a string array.

## Object Scope

The notion of object scope has been mentioned several times. The scope of a name is the range of visibility of the name. MMS defines three scopes: VMD wide scope, domain wide scope, and Application Association wide scope. A name with a VMD wide (or VMD specific) scope can be seen by all objects in the VMD. It exists for as long as the VMD exists. A name with a domain wide (or domain specific) scope can be seen by all objects in a domain but not by objects outside the domain. It exists for as long as the domain that contains it exists and ceases to exist when its containing domain is destroyed. Similarly, a name with an Application Association wide (or AA specific) scope can be seen by all objects defined on that association. It exists for as long as the defining association exists and is destroyed when the defining association is destroyed. Each object reference in MMS includes the scope in which the name should be sought. This allows scope information to become part of resolving the name so that identical names in different scopes can be unambiguously accessed. Objects of the same kind in the same scope must have different names in order to be accessible.

## Series 90-70 PLC Application

The function of the application in a Series 90-70 PLC is primarily to control the manufacturing process. To minimize the communication burden on the application, many of the MMS services requested of a Series 90-70 UE are handled entirely by the Ethernet Interface software. Since the Ethernet Interface knows all object names and attributes, it can provide this information to requesting clients without intervention from the Series 90-70 PLC application. Only the services which require application action are passed by the Ethernet Interface software to the Series 90-70 PLC application.

## Naming and Addressing

Applications are identified by an *Application Common Name* which resolves into an address where the application resides. The common name is a string of characters which contains human readable text. The address associated with this name consists of a set of entries which are mostly interpreted as strings of bits and are more obscure for the human reader. These strings of bits represent the address information for each OSI protocol in order to reach the destination application. Many of these addresses are Service Access Point (SAP) selectors which identify how the information is to be routed through the layers to the proper layer entity above.

In the upper protocol layer, there are also items called object identifiers which are used to specify an object in the OSI environment. Objects are located in a hierarchical tree and are unambiguously identified by a path between nodes in this tree. The figure below shows a typical object identifier and its place in the object space. The path to locate this object is denoted {2 1 1}.

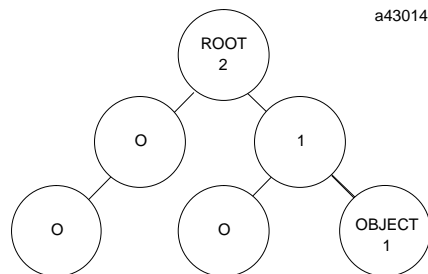

Figure B-17. MMS Object Identifier

The MAP directory service is used to resolve a common name to all required address information to locate that application. If you are using a directory server, the only address which must be present in the Series 90-70 PLC configuration is the address of the directory server. In addition to, or in place of, a directory server, it is possible to preconfigure the addresses of some remote applications into each Series 90-70 PLC configuration. The efficiency of using such statically configured information must be balanced against the complexity of managing directory information in each node rather than centrally when a directory server is used.

# Appendix C

## Protocol Implementation Conformance Statement (PICS)

---

---

This section contains the Protocol Implementation Conformance Statement (PICS) for the Manufacturing Message Specification (MMS), the Network Management Agent (NMA), and the Directory User Agent (DUA).

### PICS for the Manufacturing Message Specification (MMS)

Table C-1. PICS Series 90-70 PLC System ID Information

Description	Value
Implementation's Vendor Name	GE_Fanuc
Implementation's Model Name	Series_90-70 PLC
Implementation's Revision Identifier	1.13 RAM 1.14 PROM
Machine Name(s) and Version Number(s)	Series 90-70
Operating System(s)	N/A
MMS abstract syntax	MMS
MMS Version Number Supported	0, 1
MMS Companion Standard abstract syntaxes	N/A
MMS Companion Standard Version Number Supported	N/A
Calling MMS-user (indicate "Yes" or "No")	Yes
Called MMS-user (indicate "Yes" or "No")	Yes
List of Standardized Names	None

**Table C-2. PICS Supported Services**

<b>Description</b>	<b>Service: Server, Client or Both</b>	<b>Description</b>	<b>Service: Server, Client or Both</b>
Initiate	Both	GetDomainAttributes	
Conclude	Both	CreateProgramInvocation	
Cancel	Both	DeleteProgramInvocation	
UnsolicitedStatus	Both	Start	Both
Status	Both	Stop	Both
GetNameList	Both	Resume	Both
Identify	Both	Reset	Both
Rename		Kill	
GetCapabilityList	Server	GetProgramInvocationAttributes	Server
Read	Both	ObtainFile	
Write	Both	DefineEventCondition	
InformationReport	Both	DeleteEventCondition	
GetVariableAccessAttributes	Server	GetEventConditionAttributes	
DefineNamedVariable		ReportEventConditionStatus	
DefineScatteredAccess		AlterEventConditionMonitoring	
GetScatteredAccessAttributes		TriggerEvent	
DeleteVariableAccess		DefineEventAction	
DefineNamedVariableList		DeleteEventAction	
GetNamedVariableListAttributes		GetEventActionAttributes	
DeleteNamedVariableList		ReportEventActionStatus	
DefineNamedType		DefineEventEnrollment	
GetNamedTypeAttributes		DeleteEventEnrollment	
DeleteNamedType		AlterEventEnrollment	
Input		ReportEventEnrollmentStatus	
Output		GetEventEnrollmentAttributes	
TakeControl		AcknowledgeEventNotification	
RelinquishControl		AttachToEventCondition	
DefineSemaphore		EventNotification	
DeleteSemaphore		GetAlamSummary	
ReportSemaphoreStatus		GetAlamEnrollmentSummary	
ReportPoolSemaphoreStatus		ReadJournal	
ReportSemaphoreEntryStatus		WriteJournal	
AttachToSemaphore		InitializeJournal	
InitiateDownloadSequence		CreateJournal	
DownloadSegment		DeleteJournal	
TerminateDownloadSequence		ReportJournalStatus	
InitiateUploadSequence		FileOpen	
UploadSegment		FileRead	
TerminateUploadSequence		FileClose	
RequestDomainDownload		FileRename	
RequestDomainUpload		FileDelete	
LoadDomainContent		FileDirectory	
StoreDomainContent			
DeleteDomain			

**Table C-3. PICS Supported Parameters**

Description	Supported (Value)
STR1	Yes
STR2	
NEST ( >=0 Give integer value)	1
VNAM	Yes
VADR	Yes
VALT	Yes
VSCA	
TPY	

**Table C-4. PICs Range of Values**

Description	Value
Range of values for floating point numbers	+/- (8 x 10 <sup>-37</sup> to 3 x 10 <sup>38</sup> )
Supported values of the floating point exponent width	8 (bits)
Supported values of the floating point mantissa width	16 (bits)
Range of values for signed integer	-2 <sup>32</sup> to 2 <sup>31</sup>
Range of values for unsigned integer	0 to 2 <sup>31</sup>
Maximum length for the IA5string in octets	4096
Maximum length for VisibleString in octets	4096
Maximum length for BIT STRING in bits	16384
Maximum length for OCTET STRING in octets	4096
Addressformats for VADR horizontal CBB	Numeric Symbolic Unconstrained
Maximum Input Time Out in seconds	N/A
Level of support for time	(See Note 1)
Granularity of time in milliseconds	1000
Uninterruptible access to variable	All, up to 256 octets
Priority processing for semaphores	N/A
Capabilities of VMD	(See Note 2)
Local Detail	(See Note 3)
File Name Syntax	N/A
Range of Acceptable Segment Sizes	64 - 512 octets
Range of Maximum Services Outstanding Calling	0 to 6
Range of Maximum Services Outstanding Called	1 to 6
Start Argument	(See Note 3)
Additional Code in Error Type	N/A
Additional Detail in Error Type	(See Note 4)

Note 1 -  
Note 2 -

Note 3 -

Note 4 -

Time sequence identifier is supported.  
 Capability BASEADDR = <symbolic address> can be used to specify the load address of a domain. All other capabilities are matched with no other semantics assigned.  
 These parameters are provided and processed by the PLC application with no semantics assigned by the MMS provider.  
 Additional Detail in errors are visible strings containing descriptive error messages.

# Appendix *D*

## *Communication Ports Characteristics*

---

---

This appendix describes the Ethernet Interface serial port used to connect to the GSM and the AUI port used to connect to the network transceiver.

### **What this Appendix Contains**

Information pertaining to the Serial Port for Local GSM communications

- Serial Port Pinouts
- Serial Cable Diagrams

Information pertaining to the Attachment Unit Interface (AUI) Port for Ethernet communications

- AUI Port Pinouts
- AUI Cable Diagram
- Transceiver Unit Description

## Serial Port for Local GSM Communications

This section presents the information you need to construct a cable for serial communications between the Ethernet Interface and the Local GSM or other serial terminal. Information in this section includes serial port settings, pinouts, and cable diagrams.

### Serial Port Settings

The serial port (COM1) must be set to 9600 bps, 8 bits, no parity, and 1 stop bit.

### Serial Port Pinouts

The serial port is located on the front edge of the Ethernet Interface. The serial port is a 9-pin D-type female connector that presents an RS-232 DTE Interface. It is used to connect the Ethernet Interface to the local GENet System Manager (GSM). Connector pinouts are shown in Table D-1.

Table D-1. Pinouts of the Serial Port

Pin Number	Signal	Description
1	Shield	ChassisGround (optional)
2	TXD	Transmit Data (output)
3	RXD	Receive Data (input)
7	Common	Signal Ground
(allothers)		Unused

### Serial Cable

A serial cable is needed to connect the GSM to the Ethernet Interface. The next two figures illustrate typical cable connection of a personal computer. Figure D-1 shows connections to a personal computer with a 25-pin serial port and Figure D-2 shows connections to a personal computer with a 9-pin serial port.

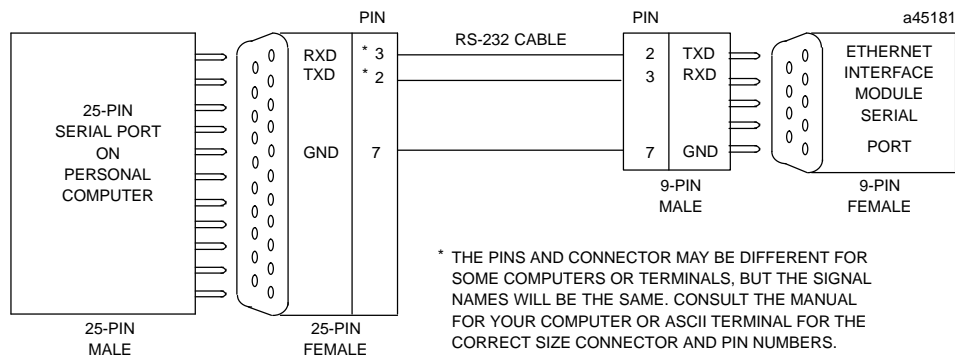
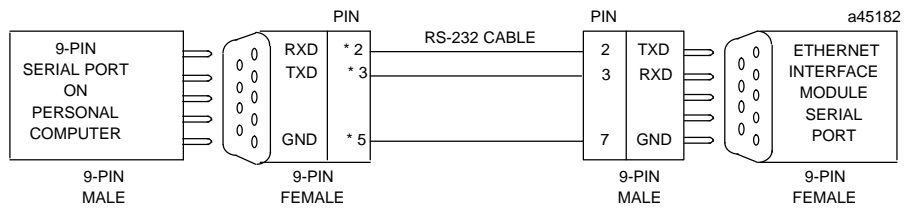

Figure D-1. Serial Cable to Connect GSM (25-Pin Connector) to Ethernet Interface



\* THE PINS AND CONNECTOR MAY BE DIFFERENT FOR SOME COMPUTERS OR TERMINALS, BUT THE SIGNAL NAMES WILL BE THE SAME. CONSULT THE MANUAL FOR YOUR COMPUTER OR ASCII TERMINAL FOR THE CORRECT SIZE AND PIN NUMBERS.

Figure D-2. Serial Cable to Connect GSM (9-Pin Connector) to Ethernet Interface

## Display Terminal Settings

When used as a local Station Manager terminal, set the terminal to “Wrap-Around” mode. This prevents loss of information in the event a Station Manager command response exceeds the display line width of the terminal.



## The AUI Port for the Ethernet Interface

The Ethernet Interface is equipped with an AUI port for connecting to the network. The IEEE 802.3 AUI (Attachment Unit Interface) is standard across a variety of different physical media. Compatible transceivers can be purchased that support 10Base5 and 10Base2 coaxial cables as well as twisted pair and fiber optic cables. The standard AUI makes your selection of transceiver and trunk cable medium transparent to the Ethernet Interface.

Your cables must meet the applicable IEEE 802.3 standards.

This section presents the information you need to specify the cables and related components required for Ethernet Communications. Information in this section includes Attachment Unit Interface (AUI) port pinouts and AUI cable diagrams.

### Ethernet AUI Port Pinouts

The AUI port is located on the front edge of the Ethernet Interface. This port is a 15-pin D-type female connector. It is used to connect the Ethernet Interface to the 802.3 transceiver. Connector pinouts are shown in Table D-2.

Table D-2. Pinouts of the AUI Port

Pin Number	Signal	Description
1	GND	Signal Ground
2	CP+	Collision Presence +
3	TX+	Transmit +
4	GND	Signal Ground
5	RX+	Receive +
6	GND	Signal Ground
7	NC	Not Connected
8	GND	Signal Ground
9	CP-	Collision Presence -
10	TX-	Transmit -
11	GND	Signal Ground
12	RX-	Receive -
13	+12	+12 Volts
14	GND	Signal Ground
15	NC	Not Connected
SHELL		Chassis Ground

## AUI (Transceiver Cable)

The figure below shows a typical cable configuration to connect the AUI port of the Ethernet Interface to an external transceiver.

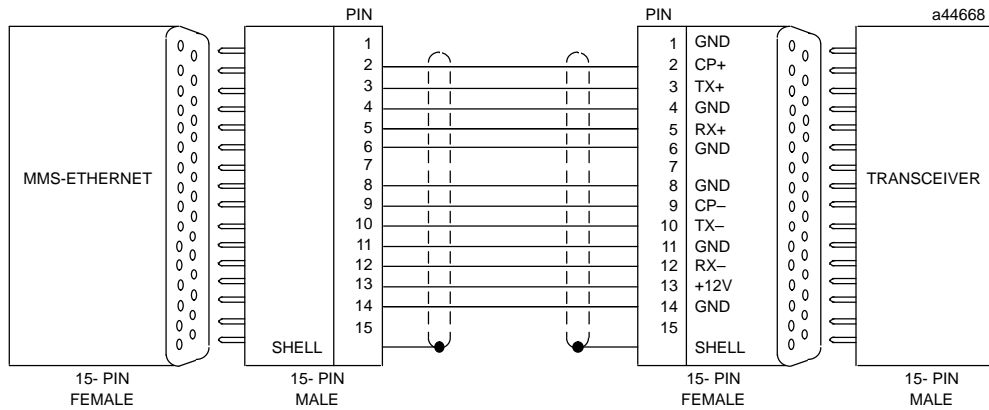

**Figure D-3. Transceiver Cable Connection**

### Note

Pinouts are provided for troubleshooting purposes only. Cables are readily available from commercial distributors. GE Fanuc recommends that you purchase rather than make transceiver cables.

## Transceiver Description

Depending on your particular application, any of several types of user-supplied transceivers may be used. Make sure the transceiver supports SQE. The two most commonly used in industrial environments are: 10Base5 and 10Base2. A typical configuration for each unit is shown in Figures D-3 and D-4.

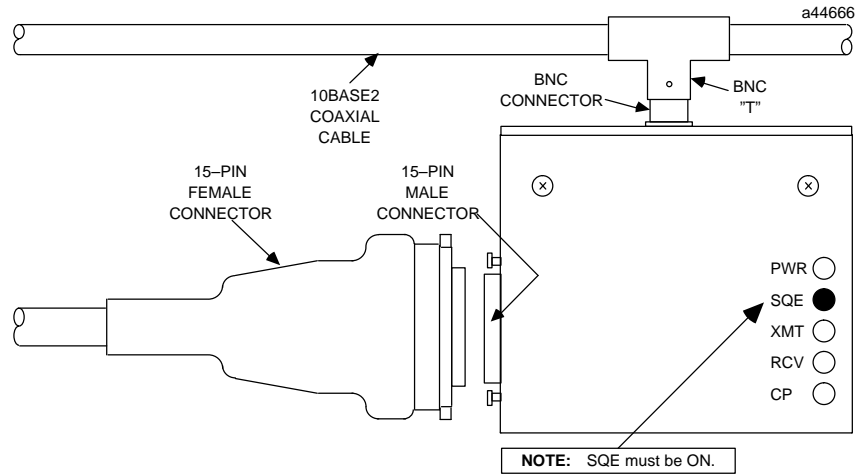

Figure D-4. 10Base2 Transceiver Configuration

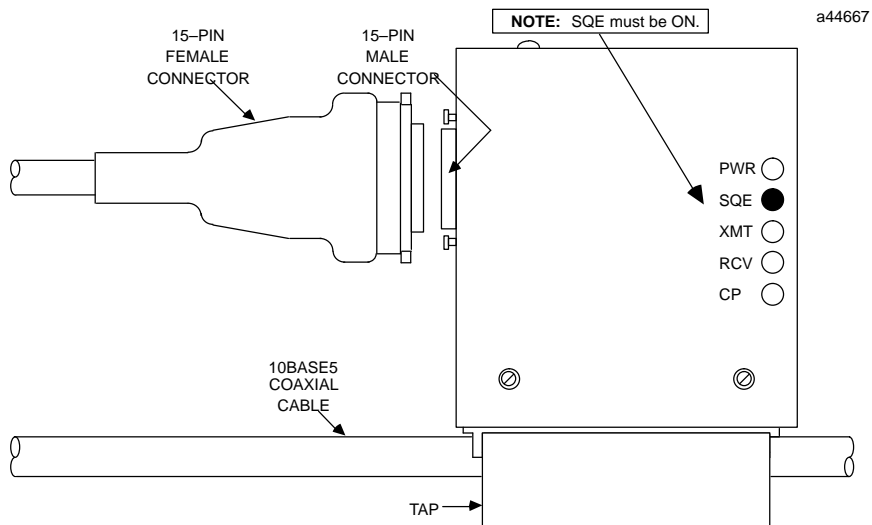

Figure D-5. 10Base5 Transceiver Configuration

### Note

Transceivers must be 802.3-compatible and must have the SQE option Enabled.

### Caution

**PLC power must be OFF when connecting or disconnecting the transceiver.**

# Appendix *E*

## *Soft Switch Parameters*

---

---

This appendix describes the parameters and settings that may be modified when configuring the GEnet™ Ethernet Interfaces. It also describes the methods for configuring the Ethernet Interface through either the Station Manager or the Logicmaster™ 90-70 Configurator.

The Ethernet Interface has a set of fundamental parameters stored in non-volatile memory (retentive when power is off). This memory is called Electronically Erasable Programmable Read Only Memory (EEPROM). These parameters are maintained indefinitely with or without power. This set of parameters is called “Soft Switches.” Soft Switches specify basic parameters in software rather than using hardware jumpers or switches. These parameters are required to support the loader and communications software of the Ethernet Interface. Soft Switches are set to default values at the factory that are correct for most LAN installations. Review the values in Table E-1 to determine if the factory default values are appropriate for your network.

### Station Address

The Station Address parameter defines the station’s MAC address used on the network. Unless your network is using local address administration, this value should be left at the default value (all zeroes). This allows the factory assigned, unique default station address (which appears on the default station address label on the controller board) to be used as the MAC address.

If you are using local address administration, this Soft Switch parameter is used to set the station address to a valid locally-administered individual station address. If you are not familiar with MAC address formats, refer to “Structure of the MAC Address” in Chapter 3.

#### Caution

**If you assign a new MAC address, record its value. Setting an improper MAC Address value, or duplicating the address of another station can disrupt other stations on the network.**

## Load Source

The Load Source parameter tells the Ethernet Interface the source for its software download.

- The default setting is “ALT”. This cycles between local and network load sources, starting with local. This method selects the first available load source.
- This parameter may also select local or network downloading exclusively. See Table E-1 for more information.

## LAN Online

The LAN Online parameter tells the Ethernet Interface whether or not it should connect to the network after diagnostics. The default setting is YES.

## Backplane Online

This parameter tells the Ethernet Interface whether or not to allow backplane communications after initialization. The default setting is YES.

## Network Load Address

The Network Load Address parameter specifies the multicast address used by this station to receive network download multicast messages. This parameter is used *only* for network downloading. The default value of zeroes means use the default network load address (090060000000).

A network GSM which is ready to provide network downloading identifies itself on the network by sending a message to one or more download multicast addresses. This message contains network data needed by a station to enter the network and request a download. Each station recognizes a network GSM downloader at only one specific download multicast address: the address specified in the Network Download Address parameter.

The Network Load Address must be a valid MAC multicast address; the Individual/Group address (I/G) bit must be set to “1”. That is, the first byte of the address must have its least significant bit ON. If you are not familiar with address formats, refer to “Structure of the MAC Address” in Chapter 3.

### Note

The Network Load Address parameter should be changed *ONLY* if there is a GENet System Manager (GSM) which is configured to use this address. Changing the Network Load Address to an address not used by some GSM on the network will cause the station to be unable to receive a network download.

## Modify Soft Switch Settings

Refer to the table below for the default Soft Switch settings and Soft Switch modification information.

Table E-1. Soft Switch Settings

Parameter	Description
<b>StationAddress</b>	<p>The station address parameter is the Medium Access Control (MAC) address of the station being configured. The MAC address is a 12-digit hexadecimal number which is organized as 6 octets, each represented by a pair of hexadecimal digits.</p> <p><b>DefaultSetting</b> - The default value is &lt;&lt;000000000000&gt;&gt; . This value instructs the Ethernet Interface to use the factory-set, globally-unique MAC address in its EEPROM.</p> <p><b>ModificationfromDefaultSetting</b> - If changed, the Ethernet Interface will store the new Station Address in the EEPROM and use it instead of the factory default.</p>
<b>LoadSource</b>	<p>The load source field defines the load source for the GENet LAN software.</p> <p><b>DefaultSetting</b> - The default setting for this field is "ALT". This means that the GENet Ethernet Interface module will try to obtain a load from the serial port and the network (in that order). The software will alternate between the two load sources until one is found.</p> <p><b>ModificationfromDefaultSetting</b> - You may wish to specify the load source. The load source may be changed to:  "LOC" (serial port) - only  "NET" (network) - only  If the load source specified is not available for the module, it will wait indefinitely for that load source to be made available.</p>
<b>LANOnline</b>	<p>This parameter tells the GENet LAN Interface module whether to connect to the LAN after initialization.</p> <p><b>DefaultSetting</b> - The default setting is YES. This means that the module will connect to the LAN.</p> <p><b>ModificationfromDefaultSetting</b> - The value may be changed to NO. This means that the module will <i>not</i> connect to the LAN.</p>
<b>BackplaneOnline</b>	<p>This parameter tells the GENet LAN Interface module whether or not to allow backplane communications.</p> <p><b>DefaultSetting</b> - The default setting is YES. This means that the module will allow all forms of backplane communications.</p> <p><b>ModificationfromDefaultSetting</b> - The value may be changed to NO. This means that the module will only allow diagnostics mail traffic. This setting will <i>not</i> permit application data transfer with the Series 90-70 CPU.</p>
<b>NetworkLoadAddress</b>	<p>The multicast address to be used by the LAN Interface to load across the LAN. It is in the same format as the Station Address.</p> <p><b>DefaultSetting</b> - The default value is &lt;&lt;000000000000&gt;&gt; . This value instructs the LAN Interface to use the default network load address, &lt;&lt;090060000000&gt;&gt;, as its load address.</p> <p><b>ModificationfromDefaultSetting</b> - If changed the Ethernet Interface will look for a network load from the specified multicast address. This MUST be a multicast address.</p>

## Configuring Soft Switch Parameters

The Series 90-70 Ethernet Interface supports two methods for setting Soft Switches:

- The Logicmaster 90-70 Configurator software package, which passes the data to the Series 90-70 PLC CPU.
- The Ethernet Interface Station Manager *CHSOSW* command.

### Note

The *CHSOSW* command can only be used when the Ethernet Interface is not configured in the local PLC by the Logicmaster 90-70 Configurator. Logicmaster 90-70 is the primary method for configuring soft switches.

This manual does not describe Soft Switch configuration through the Logicmaster 90-70 Configurator software. Refer to Chapter 11 of GFK-0263 *Logicmaster™ 90 Programming Software User's Manual* for information on configuring your Ethernet Interface using Logicmaster 90-70 Configurator software.

To configure your Ethernet Interface using the GENet Station Manager *CHSOSW* command, refer to the following information.

## Configuring Soft Switch Parameters Using the GSM

Perform the steps described here to set the Soft Switch values using the GENet Station Manager when:

- You wish to change the default Software Switch values, and do not have the Logicmaster 90 configurator software.
  - An Ethernet Interface is in the Soft Switch Entry Utility as indicated by the Soft Switch LED pattern display (module OK LED blinking slowly, other LEDs OFF).
1. Connect a serial cable, as shown in Appendix D, from the 9-pin port on the Ethernet Interface Controller board to a GSM or other terminal device (9600 - 8 data bits, 1 stop bit, no parity). If using the GSM, proceed to step 2, otherwise skip to step 5.
  2. Power up the personal computer into DOS, and select the proper drive and directory by typing the following command:  

```
C:\>cd \gsm
```
  3. To initiate the GSM, from the DOS prompt, type:  

```
\GSM> gsm term
```
  4. The screen will display the GSM Local Station Manager Terminal menu.
  5. Press the Ethernet Interface Restart button.

6. Text similar to that shown below will be displayed on the terminal after the diagnostics are run. The Soft Switch Entry Utility banner will appear only if the Ethernet Interface is in the Soft Switch Entry state. The *CHSOSW* command may be used in any of the Ethernet Interface states.

```
IC697 PLC Factory LAN Interface
Copyright (c) 1990-1994. All rights reserved
PROM version 1.14 Ethernet
MAC address = <<08001901001f>>
Serial no. 01393790, MAC default = <<08001901001f>>

<<< Soft Switch Entry Utility >>>
```

7. A "\*" or other prompt character will be displayed on the terminal.
8. To display the current values of the Soft Switches, enter the command *SOSW*.
9. Set the values of the Soft Switches by entering the *CHSOSW* command. (Refer to Chapter 4, Station Manager, for a detailed definition of the command syntax.)

The new values of the Soft Switches will be displayed. A typical *CHSOSW* command for the Ethernet Interface is shown below:

```
* chsow mac 020106000001 mms dc
<<< Soft Switch Data >>>
MAC Address = <<08001901001f>> (default used)
Load source = Serial
Network Online = Online after power up
Backplane Online = Online after power up
Network doad addr = <<090060000000>> (default used)
MMS Enable = Don't Care
Pgm Enable = Don't Care
Updating, please wait ...
```

10. If the Soft Switch data displayed in the *CHSOSW* command is correct for the station, press the LAN Interface Restart button to cause the new Soft Switch values to take effect. If the values shown are not what you want, repeat step 10, supplying the proper values.

**Caution**

Soft switch values set by the *CHSOSW* Station Manager command will be overridden by values configured in the Logicmaster 90-70 Configurator the next time the LAN Interface board restarts.

### Correct Results of Soft Switch Configuration

- If the values displayed from the *CHSOSW* command are not correct, reenter the command with the desired parameters. Enter the command *SOSW* to see the current Soft Switch values.
- If the Soft Switch LED pattern is displayed but no "sign-on message" or prompt appears on the terminal, check the construction and connections of the serial cable and verify that the terminal is operating at the 9600 bps data rate. The sign-on message can be repeated by pressing the LAN Interface Restart button.



# Appendix F

## Station Configuration Parameters

The LAN configuration parameters allow the station to communicate in a variety of network environments. This appendix describes the entire set of configuration parameters. Most of these parameters can be changed in the configuration file on the hard disk using the GENet™ System Manager (GSM) and then downloaded to the LAN Interface.

The parameters can also be viewed online using the Station Manager *SHOW* command. You will notice that the parameter *names* shown here and used by the station manager are abbreviated from the corresponding names on the GSM. Chapters 3 and 8 show both sets of names when describing the GSM Configuration Editor menus. Also notice that the *values* shown here and by the Station Manager may be different from those shown on the GSM (e.g., *lrxringlen* and *tmaxpdu*).

### Configuration Parameters via the Station Manager

The table below lists the configuration parameters as viewed via the Station Manager .

Table F-1. Configuration Parameters via the Station Manager

Parameter	Format	Default	Description
<b>ApplicationLayer Parameters</b>			
alsap	hex	FE	LLC Service Access Point (LSAP) for ISO/Ethernet services. This parameter specifies the LSAP to be used for the MMS-Ethernet communications services. The LSAP value should be hexadecimalFE.
applapt	objid	{ }	ApplicationInterface APT object identifier.
applcnam	str	APPL<MAC addr>	Common Name for the Application Interface. This parameter is a character string of up to 64 characters.
applaequal	dec	0	ApplicationInterface AP ApplicationEntity qualifier. Range 0 - 65535.
applpsap	hex	00000002	Presentation Service Access Point (PSAP) for the Application Interface. This parameter is an octet string of up to 4 octets.
applssap	hex	0001	Session Service Access Point (SSAP) for the Application Interface. This parameter is an octet string of up to 16 octets.
arespapt	objid	{ }	Responder APT object identifier.
arespaequal	dec	0	Responder AP ApplicationEntity qualifier. Range 0 - 65535.
arespcnam	str	RESP<MAC addr>	Common Name for the Responder. This parameter is a character string of up to 64 characters.
aresppsap	hex	00000001	Presentation Service Access Point (PSAP) for the Default Responder. This parameter is an octet string of up to 4 octets.

**Table F-1. Configuration Parameters via the Station Manager - Continued**

<b>Parameter</b>	<b>Format</b>	<b>Default</b>	<b>Description</b>
arespsap	hex	0001	Session Service Access Point (SSAP) for the Default Responder. This parameter is an octet string of up to 16 octets.
assocappl	dec	8	Maximum number of simultaneous associations for the ApplicationInterface communication services. This parameter identifies how many total Application Interface associations may exist at the same time. The sum of the active <i>assocappl</i> and <i>assocresp</i> parameters must be less than or equal to 8. (8 is the maximum number of total simultaneous associations that may exist at a time.) Range 0 - 8.
assocresp	dec	8	Maximum number of simultaneous associations for the Responder communication services. This parameter identifies how many total Responder associations may exist at the same time. The maximum number of simultaneous associations that may exist at a time is 8. (Range 0 - 8)
<b>System Parameters</b>			
balloc1	dec	9	Buffer pool 1 memory percent. The available memory after all of the Ethernet Interface executive program and data has been loaded is broken into the four fixed size block pools. Each pool receives a percentage of the available memory. This parameter specifies the percentage of available memory to be allocated to pool 1. For example, a value of 10 in this field would assign ten percent of the available memory after loading to pool 1. The total of the parameter values for parameters <i>balloc1</i> , <i>balloc2</i> , <i>balloc3</i> , and <i>balloc4</i> must not exceed 100. If it is less than 100, some available memory will not be used. Decimal Range 1 - 97.
balloc2	dec	7	Buffer pool 2 memory percent. Decimal Range 1 - 97.
balloc3	dec	45	Buffer pool 3 memory percent. Decimal Range 1 - 97.
balloc4	dec	39	Buffer pool 4 memory percent. Decimal Range 1 - 97.
bbuff1	dec	28	Buffer pool 1 buffer size. The buffers used by the Ethernet Interface software are allocated into four fixed size block pools. This parameter specifies the size in bytes of fixed size block pool 1 buffers. One of the pools must be set to sufficient size to contain the largest frame specified in the <i>lmaxdb</i> parameter.  Clearly, the larger the buffer size set in the pools, the smaller the number of available buffers. The memory usage is most efficient if the buffer sizes are 4 less than a multiple of 16. This parameter must be in the decimal range 1 - 1024.
bbuff2	dec	60	Buffer pool 2 buffer size. Decimal Range 1 - 2048.
bbuff3	dec	380	Buffer pool 3 buffer size. Decimal Range 1 - 4096.
bbuff4	dec	1569	Buffer pool 4 buffer size. Must meet all the following qualifications: <i>bbuff4</i> ( <i>mmaxmsgsz</i> + 168) <i>bbuff4</i> ( <i>tmaxpdu</i> + 150) <i>bbuff4</i> ( <i>lmaxdb</i> + 72) Decimal Range 1 - 8192.
bstnmgrlsap	hex	E8	Station Manager LSAP for sending and receiving REMote commands and responses.
bstnmgrpri	dec	0	Station Manager priority for sending REMote commands and responses.

**Table F-1. Configuration Parameters via the Station Manager - Continued**

Parameter	Format	Default	Description
<b>DataLink Layer Parameters</b>			
ldrtry	dec	0	When <i>ldrtry</i> = 1, retrying is disabled and the MAC layer will attempt only one transmission of a packet. When <i>ldrtry</i> = 0, up to 16 retries will be attempted.
lgrpadr0	hex	09002B000004	Eight Group receive addresses. Multicast (Group) frames will be received only when addressed to the broadcast address (ffffffff) or to one of these addresses. A zero value indicates an unused entry. The default value for the first entry is the All-ES address (also see <i>nesma</i> ).
lgrpadr1	hex	090019000001	Group Address for SRTP
lgrpadr2	hex	000000000000	Available Group Address
lgrpadr3	hex	000000000000	"
lgrpadr4	hex	000000000000	"
lgrpadr5	hex	000000000000	"
lgrpadr6	hex	000000000000	"
lgrpadr7	hex	000000000000	"
lmacaddr	hex	000000000000	Local station MAC address. This field should be set to a valid MAC individual station address or to the value zero to use the default address for the station. To see the default station address, look at the sticker on the Ethernet Interface or use the Station Manager <i>NODE</i> command. Refer to Chapter 3, in the section entitled, "Structure of the MAC Address" for the definition of valid MAC address.
lmaxdb	dec	1497	Maximum LLC buffer size. The size for LLC receive buffer allocation. This value will determine the largest possible receive frame for the LLC layer. ( <i>bbuff4</i> must be at least 72 bytes greater than <i>lmaxdb</i> )
lrxringlen	dec	5	This parameter is used as a power of two (2) to get the size of Receive Ring on the MAC device. This is the maximum number of received frames that may be queued for processing. This parameter should be enlarged when a large number of frames are being received by the station to avoid losing receive frames (and logging event c, entry 2=103). Range 3 - 7. The default value of 5 corresponds to a ring size of 32.
ltxringlen	dec	3	This parameter is used as a power of two (2) to get the ring length. Size of the Transmit Ring on the MAC device. This is the maximum number of frames that may be queued to the transmitter Range 3 - 7. The default value of 3 corresponds to a ring size of 8.
<b>MMS Parameters</b>			
maltacn	str	ISO MMS1	ApplicationContext Name string name for alternate MMS ApplicationContext. (Not GSM configurable)
maltacobj	objid	{ }	Alternate MMS Application Context object identifier.

**Table F-1. Configuration Parameters via the Station Manager - Continued**

<b>Parameter</b>	<b>Format</b>	<b>Default</b>	<b>Description</b>
mmaxmsgsz	dec	992	Maximum application message size. This parameter determines the maximum length of a MMS message that can be sent or received. This parameter also determines the maximum message size which is negotiated between two applications if they indeed negotiate maximum message size. This parameter must be 168 less than <i>buff4</i> , or smaller.
mmsacn	str	ISO MMS	ApplicationContext Name string for MMS Application context. (Not GSM configurable)
mmsacnobj	objid	{1 0 9506 2 3}	MMS Application Context object identifier.
<b>Network Layer Parameters</b>			
ncfgtime	dec	30	Configuration timer interval in seconds.
nchksum	dec	0	Use checksums on outgoing NPDUs. 0 means do not use checksums, 1 means use checksums.
neslsap	hex	FE	All End-Systems (ES) LSAP.
nesmac	hex	09002B000004	All End-Systems (ES) MAC address.
nhldtime	dec	75	Holding timer for outgoing ES-IS NPDUs in seconds.
nislsap	hex	FE	All Intermediate-Systems (IS) LSAP.
nismac	hex	09002B000005	All Intermediate-Systems (IS) MAC Address.
nmaxpdu	dec	1497	Maximum network PDU size for the Network Layer.
noptmiz	dec	0	Use ISO 9542 optimization. 0 means do not use optimization, 1 means use optimization.
npdulife	dec	10	Lifetime of outgoing ES-ES NPDUs in half-seconds.
npriority	dec	7	LLC data packet priority for ISO services. This parameter specifies the LLC priority at which the Network Layer data-packets are sent on the LAN. Range 0 to 7.
nqwttime	dec	45	Query configuration wait timeout in seconds.
nsap	hex	49<MAC addr>01	Network Service Access Point. This parameter specifies the NSAP to be used for the communication services. 1-20 octets.
ntick	dec	10	Seconds between checking clock.
<b>Presentation Layer Parameters</b>			
pacsepci	dec	7	ACSE Presentation Context Identifier. (Not GSM configurable)
pacesynnam	str	ISO 8650-ACSE1	ACSE Syntax Name. (Not GSM configurable)
pacesynobj	objid	{ 2 2 1 0 1 }	ACSE Syntax Name Object Identifier.
pmmspci	dec	5	MMS Presentation Context Identifier. (Not GSM configurable)
pmmssynam	str	MMS PCI	MMS Syntax Name. (Not GSM configurable)
pmmssynobj	objid	{ 1 0 9506 2 1 }	MMS Syntax Name Object Identifier.
pxferpci	dec	9	Transfer Syntax Presentation Context Identifier. (Not GSM configurable)
pxfersynnam	str	BASICEN-CODING	Transfer Syntax Syntax Name. (Not GSM configurable)
pxfersynobj	objid	{ 2 1 1 }	Transfer Syntax Syntax Name Object Identifier.

**Table F-1. Configuration Parameters via the Station Manager - Continued**

<b>Parameter</b>	<b>Format</b>	<b>Default</b>	<b>Description</b>
<b>SessionLayer Parameters</b>			
stime	dec	2500	Session Timeout for the Session Layer. This timer establishes the maximum interval to wait before disconnecting the Transport connection. It allows time for a connection-ending Session PDU to reach its destination. This parameter is in units of 10 milliseconds. The default value for this parameter is 25 seconds. Range 1 - 65535.
stsap	hex	0001	Transport Service Access Point (TSAP). This parameter specifies the TSAP to be used for the ISO communications services.
<b>Transport Layer Parameters</b>			
tchksum	dec	0	Checksum Negotiation for the TransportLayer. This parameter determines whether or not the Transport checksums are negotiated during Transport connection establishment. "0" for this parameter specifies that checksums are not negotiated. "1" for this parameter specifies that checksums are negotiated. Range 0 - 1.
tflowctrl	dec	0	Flow Control Timeout for the TransportLayer. This timer is reserved for future use.
tgiveup	dec	1500	Give up timeout for the TransportLayer. This timer is started when a TPDU has been re-transmitted the maximum number of times. If it times out before an acknowledgement is received for the TPDU, the Transport connection is broken. This parameter is in units of 10 milliseconds. The default value for this parameter is 15 seconds. Range 1 - 65535.
tinactive	dec	6000	Inactivity Timeout for the TransportLayer. This timer establishes the maximum time that the Transport connection will be maintained without receiving a TPDU. This parameter is in units of 10 milliseconds. The default value for this parameter is 60 seconds. Range 1 - 65535.
tlcack	dec	0	Local Acknowledge Timeout for the TransportLayer. This timer is reserved for future use.
tmaxpdu	dec	10	Maximum PDU size for the TransportLayer. This establishes the maximum TPDU size negotiated for data transfers. This parameter is used as a power of 2 to get actual size. (A value of 10 implies a size of 1024 octets.) Range 7 - 12.
treftime	dec	0	Reference Timeout for the TransportLayer. This parameter establishes the period during which a source reference cannot be reassigned to another Transport connection. Range 0 - 65535. This parameter is in units of 10 milliseconds.
trtrancnt	dec	5	Retransmit Counter for the TransportLayer. This counter establishes the maximum number of re-transmissions for Connect Request (CR), Connect Confirm (CC), Data Transfer (DT), Expedited Data (ED), and Disconnect Request (DR) TPDU's. Range 1 - 10.

**Table F-1. Configuration Parameters via the Station Manager - Continued**

<b>Parameter</b>	<b>Format</b>	<b>Default</b>	<b>Description</b>
trtrantime	dec	1500	RetransmitTimeout for the TransportLayer. When this timer expires, it causes re-transmission of unacknowledged Connect Request (CR), Connect Confirm (CC), Data Transfer (DT), Expedited Data (ED), and Disconnect Request (DR) TPDUs. This parameter is in units of 10 milliseconds. The default value for this parameter is 15 seconds. Range 1 - 65535.
twindsize	dec	2	Window Size for the TransportLayer. This parameter is the maximum window size allowed for the receipt of (Data Transfer) DT TPDUs. Range 1 - 5.
twindow	dec	2500	Window Timeout for the TransportLayer. When this timer times out, an acknowledge (AK) TPDu is transmitted. Its value should be less than that for the TransportLayer inactivity timer. This parameter is in units of 10 milliseconds. The default value for this parameter is 25 seconds. Range 1 - 65535.
<b>SRTP Parameters</b>			
vtsap	hex	0004	TSAP for SRTP communication. This parameter specifies the TSAP to be used by the SRTP Service Agent. Value is 0004.
vdpcisab	dec	0	Disable DDP operation. When non-zero, this parameter disables the Distributed Directory Protocol (DDP) operation. The default value is 0 (DDP enabled). DDP must be enabled to use Logicmaster 90-70-Ethernet.
vdptmout	dec	5	DDP Conflict Timeout. This parameter specifies the maximum timeout to detect a duplicate DDP name assignment. This parameter is in units of 100 milliseconds. The default value is 5 (500 ms). Range 1-600.
vdpretry	dec	0	Maximum DDP Resolve Retries. This parameter is reserved for future use.

# Appendix G

## Ladder Programs for Network Testing

The following ladder logic program is a printout of the program included on the Configuration Diskette. The program is referenced in Chapter 2, Installation Procedure 6: Using the Example PLC Ladder Program.

### Sample Ladder Program

```
(*****
(*)
(*)          PROGRAM BLOCK:  _MAIN          (*)
(*)
(*)
(*)
(*)  PROGRAM REGISTER (%P) MEMORY SIZE (BYTES):      0      (*)
(*)          PROGRAM BLOCK SIZE (BYTES):      360      (*)
(*)          DECLARATIONS (ENTRIES):      19      (*)
(*)
(*)
(*)          HIGHEST REFERENCE USED          (*)
(*)  -----          (*)
(*)
(*)          INPUT (%I):      NONE          (*)
(*)          OUTPUT (%Q):      %Q00013      (*)
(*)          INTERNAL (%M):      %M00003      (*)
(*)          TEMPORARY (%T):      NONE          (*)
(*)          LOCAL REGISTER (%L):      NONE          (*)
(*)          PROGRAM REGISTER (%P):      NONE          (*)
(*)          REGISTER (%R):      NONE          (*)
(*)          ANALOG INPUT (%AI):      NONE          (*)
(*)          ANALOG OUTPUT (%AQ):      NONE          (*)
(*)
(*)
(*)*****
|[ START OF LD PROGRAM ] (*)
|
|[ VARIABLE DECLARATIONS ]
```

#### VARIABLE DECLARATION TABLE

REFERENCE	NICKNAME	REFERENCE DESCRIPTION
%I00012	MEM-ACC	Network memory access LISW bit
%I00013	LAN-OK	LAN OK bit in LISW
%I00014	RSRCPRB	Resource problem LISW bit
%I00015	INITPND	Initiate ind pending LISW bit
%I00016	LANIFOK	LAN Interface OK bit in LISW
%I00017	ASSOCOK	ASW association OK bit
%I00019	POS-CNF	ASW positive confirm bit
%I00020	NEG-CNF	ASW negative confirm bit
%I00021	ABRTIND	ASW abort indication bit
%I00035	RJCTIND	ASWE reject indication bit
%I00036	ERR-IND	ASWE error indication bit





```

(*****
(*)
(*)          PROGRAM BLOCK:  ASSOC1          (*)
(*)
(*)
(*)
(*)    LOCAL REGISTER (%L) MEMORY SIZE (BYTES):  512  (*)
(*)          PROGRAM BLOCK SIZE (BYTES):  496  (*)
(*)          DECLARATIONS (ENTRIES):  6  (*)
(*)
(*)
(*)          HIGHEST REFERENCE USED          (*)
(*)    -----          (*)
(*)
(*)          INPUT (%I):  %I00048          (*)
(*)          OUTPUT (%Q):  %Q00006          (*)
(*)          INTERNAL (%M):  NONE          (*)
(*)          TEMPORARY (%T):  NONE          (*)
(*)          LOCAL REGISTER (%L):  NONE          (*)
(*)          PROGRAM REGISTER (%P):  NONE          (*)
(*)          REGISTER (%R):  %R00250          (*)
(*)          ANALOG INPUT (%AI):  NONE          (*)
(*)          ANALOG OUTPUT (%AQ):  NONE          (*)
(*)
(*****

```

```

+ [ START OF LD BLOCK ASSOC1 ]          (* Bring up LAN association *)
|
| [ VARIABLE DECLARATIONS ]

```

V A R I A B L E   D E C L A R A T I O N   T A B L E

REFERENCE	NICKNAME	REFERENCE DESCRIPTION
-----	-----	-----
%Q00001	WAS-UP	Detect 1st LAN OK & LAN i/f OK
%Q00002	INF_FL	Detect LAN i/f failure after up
%Q00003	LAN-FL	Detect LAN OK failure after up
%R00250	INIT-SW	Initiate Req COMM_REQ status wd

I D E N T I F I E R   T A B L E

IDENTIFIER	IDENTIFIER TYPE	IDENTIFIER DESCRIPTION
-----	-----	-----
GETSTAT	COMMENT	
CLRASW	COMMENT	

```

+ [ START OF BLOCK LOGIC ]
|
| << RUNG 3 >>
|
| GETSTAT
| (* COMMENT *)
|

```



```

| << RUNG 11 >>
| INITREQ +-----+
+---]^[---+BLKMV+-----+BLKMV+---
|          | INT |          | INT |
| CONST --+IN1 Q+-%R00200  CONST --+IN1 Q+-%R00207
| +00073 |          |          | +00070 |          |
|          |          |          |          |          |
| CONST --+IN2 |          |          | CONST --+IN2
| +00000 |          |          | +00016 |          |
|          |          |          |          |          |
| CONST --+IN3 |          |          | CONST --+IN3
| +00008 |          |          | +00000 |          |
|          |          |          |          |          |
| CONST --+IN4 |          |          | CONST --+IN4
| +00249 |          |          | +00000 |          |
|          |          |          |          |          |
| CONST --+IN5 |          |          | CONST --+IN5
| +00000 |          |          | +00000 |          |
|          |          |          |          |          |
| CONST --+IN6 |          |          | CONST --+IN6
| +00000 |          |          | +00000 |          |
|          |          |          |          |          |
| CONST --+IN7 |          |          | CONST --+IN7
| +08201 +-----+          | +00010 +-----+
|
| << RUNG 12 >>
| INITREQ          +-----+
+---]^[-----+COMM_+---
|          | REQ |
|          |     |
|          |%R00200--+IN FT+---
|          |     |
|          |%R00099--+SYSID|
|          |     |
|          |CONST --+TASK |
|          |00000000 +-----+
|
+ [          END OF BLOCK LOGIC          ]

```

```

(*****
(*)
(*)          PROGRAM BLOCK:  RDREG          (*)
(*)
(*)
(*)
(*)  LOCAL REGISTER (%L) MEMORY SIZE (BYTES):    0          (*)
(*)          PROGRAM BLOCK SIZE (BYTES):    481          (*)
(*)          DECLARATIONS (ENTRIES):    2          (*)
(*)
(*)
(*)          HIGHEST REFERENCE USED          (*)
(*)  -----          (*)
(*)
(*)          INPUT (%I):    NONE          (*)
(*)          OUTPUT (%Q):    %Q00013          (*)
(*)          INTERNAL (%M):    NONE          (*)
(*)          TEMPORARY (%T):    NONE          (*)
(*)          LOCAL REGISTER (%L):    NONE          (*)
(*)          PROGRAM REGISTER (%P):    NONE          (*)
(*)          REGISTER (%R):    %R00345          (*)
(*)          ANALOG INPUT (%AI):    NONE          (*)
(*)          ANALOG OUTPUT (%AQ):    NONE          (*)
(*)
(*****
+ [ START OF LD BLOCK RDREG ]          (* Read memory of remote node *)
|
+ [ VARIABLE DECLARATIONS ]

```

VARIABLE DECLARATION TABLE

REFERENCE	NICKNAME	REFERENCE DESCRIPTION
%R00251	READ-SW	Read Request COMM_REQ status wd
%Q00004	HEALTHY	

IDENTIFIER TABLE

IDENTIFIER	IDENTIFIER TYPE	IDENTIFIER DESCRIPTION
------------	-----------------	------------------------

NO IDENTIFIER TABLE ENTRIES

```

+ [ START OF BLOCK LOGIC ]
|
| << RUNG 3 >>
|
| READREQ +-----+
+---]^[---+MOVE_+---
|          | INT |
|          |   |
| CONST --+IN Q+--READ-SW
+00000 | LEN |
|          |00001|
|          |   |
|          +-----+

```



```

(*****
(*)
(*)          PROGRAM BLOCK:  WRTREG          (*)
(*)
(*)
(*)
(*)    LOCAL REGISTER (%L) MEMORY SIZE (BYTES):    0      (*)
(*)          PROGRAM BLOCK SIZE (BYTES):    590      (*)
(*)          DECLARATIONS (ENTRIES):    4      (*)
(*)
(*)
(*)          HIGHEST REFERENCE USED          (*)
(*)
(*)          -----          (*)
(*)
(*)          INPUT (%I):  %I00021          (*)
(*)          OUTPUT (%Q):  %Q00014          (*)
(*)          INTERNAL (%M):  NONE          (*)
(*)          TEMPORARY (%T):  NONE          (*)
(*)          LOCAL REGISTER (%L):  NONE          (*)
(*)          PROGRAM REGISTER (%P):  NONE          (*)
(*)          REGISTER (%R):  %R00338          (*)
(*)          ANALOG INPUT (%AI):  NONE          (*)
(*)          ANALOG OUTPUT (%AQ):  NONE          (*)
(*)
(*)
(*)
+ [ START OF LD BLOCK WRTREG ] (* Write memory of remote node *)
|
| [ VARIABLE DECLARATIONS ]

```

VARIABLE DECLARATION TABLE

REFERENCE	NICKNAME	REFERENCE DESCRIPTION
%Q00004	HEALTH	
%Q00010	MAXWRT	
%Q00011	WRT-OK	
%R00252	WRIT-SW	Write Request COMM_REQ status wd

IDENTIFIER TABLE

IDENTIFIER	IDENTIFIER TYPE	IDENTIFIER DESCRIPTION
------------	-----------------	------------------------

NO IDENTIFIER TABLE ENTRIES

```

+ [ START OF BLOCK LOGIC ]
|
| << RUNG 3 >>
|
| HEALTH MAXWRT WRT-OK
+-- [-----]/[-----]------( )--
|
| << RUNG 4 >>
|
| WRITERQ +-----+
+-- ]^[---+MOVE_+-
|
| INT
|
| CONST --IN Q+-WRIT-SW
| +00000 | LEN |
| | 00001 |
| |-----+

```

```

| << RUNG 5 >>
| WRITERQ +-----+
| ]^[---+BLKMV+-----+-----+-----+
|          | INT |          | INT |          | WORD |
|-----+-----+-----+-----+-----+
| CONST --+IN1 Q+-%R00301  CONST --+IN1 Q+-%R00308  CONST --+IN1 Q+-%R00315
| +00128 |          | +00070 |          | 0004 |          |
|
| CONST --+IN2 |          | CONST --+IN2 |          | CONST --+IN2 |
| +00000 |          | +00016 |          | 3152 |          |
|
| CONST --+IN3 |          | CONST --+IN3 |          | CONST --+IN3 |
| +00008 |          | +00002 |          | 3030 |          |
|
| CONST --+IN4 |          | CONST --+IN4 |          | CONST --+IN4 |
| +00251 |          | +00000 |          | 0000 |          |
|
| CONST --+IN5 |          | CONST --+IN5 |          | CONST --+IN5 |
| +00000 |          | +00006 |          | 0000 |          |
|
| CONST --+IN6 |          | CONST --+IN6 |          | CONST --+IN6 |
| +00000 |          | +00016 |          | 0000 |          |
|
| CONST --+IN7 |          | CONST --+IN7 |          | CONST --+IN7 |
| +08323 +-----+ | +00002 +-----+ | 0000 +-----+
|
| << RUNG 6 >>
| WRITERQ +-----+
| ]^[---+BLKMV+-----+
|          | INT |
|-----+-----+
| CONST --+IN1 Q+-%R00332
| +00000 |
|
| CONST --+IN2
| +00000 |
|
| CONST --+IN3
| +00001 |
|
| CONST --+IN4
| +00000 |
|
| CONST --+IN5
| +00001 |
|
| CONST --+IN6
| +00000 |
|
| CONST --+IN7
| +00000 +-----+

```

```

| << RUNG 7 >>
| WRT-OK WRITERQ MAXWRT +-----+
+---] [-----]^ [-----] / [----+COMM_+
|                                     | REQ |
|                                     | IN FT+
|                                     | SYSID|
|                                     | TASK |
| 00000000 +-----+
|
| << RUNG 8 >>
| FST_SCN +-----+
+---] [----+ SUB_+
|                                     | INT |
| %R00010--+I1 Q+-%R00010
| %R00010--+I2 |
|                                     +-----+
|
| << RUNG 9 >>
| WRITERQ +-----+
+---]^ [---->UPCTR+-----MAXWRT
|                                     | ( )--
|                                     |
| ALW_ON |
+---] / [----+R |
|                                     |
| CONST --PV CV+-
| +00006 |
|                                     +-----+
|
| %R00010
|
| << RUNG 10 >>
| POS-CNF
+---]^ [----+-----%Q00014
|                                     | ( )--
|                                     |
| NEG-CNF |
+---]^ [----+
|                                     |
| ABRTIND |
+---]^ [----+
|
| << RUNG 11 >>
| %Q00014 +-----+
+---]^ [----+ SUB_+
|                                     | INT |
| %R00010--+I1 Q+-%R00010
|                                     |
| CONST --I2 |
| +00001 +-----+
|
+ [          END OF BLOCK LOGIC          ]

```



# Appendix *H*

## *Sample DOS System Files*

---

---

This appendix shows prototypes for the DOS system files, CONFIG.SYS, AUTOEXEC.BAT, and PROTOCOL.INI, for each type of 802.3/Ethernet Interface supported by the GSM.

### **Note**

Also, at the end of the appendix is a section on optimizing the GSM by adjusting parameters in the [GEFNDIS] section of the PROTOCOL.INI file.

## Sample DOS Initialization Files

### 3Com Etherlink II

#### \CONFIG.SYS

```
FILES=20
BUFFERS=48
DEVICE=\DOS\HIMEM.SYS
DEVICE=\DOS\EMM386.EXE RAM 1024
DOS=HIGH,UMB
DEVICE=\GEFNDIS\PROTMAN.DOS/I:\GEFNDIS
rem
rem The Ethernet Adapter and its device driver must first be installed
rem into your computer. Replace the string "<DIRECTORY>" in the
rem following DEVICEHIGH command with the directory which contains
rem the specified device driver for your Ethernet Adapter module.
rem
DEVICEHIGH=\<DIRECTORY>\ELNKII.DOS
DEVICEHIGH=\GEFNDIS\GEFNDIS.DOS
```

#### \AUTOEXEC.BAT

```
SET GSMCFG=C:\GSM\CFILES

rem Bind NDIS Drivers
\GEFNDIS\netbind
```

#### \GEFNDIS\PROTOCOL.INI

```
[protocol manager]
  DRIVERNAME = PROTMAN$

[GEFNDIS]
  DRIVERNAME = GEFNDIS$
  BINDINGS = ETHERLINKII
  MAX_RX_SIZE = 560
  NUM_RX_BUFS = 8

; Caution: Interrupt conflicts may arise when using default hardware
; configurations for many Ethernet Adapters. For example,
; interrupt IRQ3 is commonly used for the COM2 serial port
; and most Ethernet adapters.
;
; The following information must match the hardware configuration
; of the Ethernet Adapter as installed on your computer. Please
; modify this information as necessary.

[ETHERLINKII]
  DRIVERNAME = ELNKII$
  DMACHANNEL = 1
  INTERRUPT = 3
  IOADDRESS = 0x300
  MAXTRANSMITS = 8
```

## 3Com Etherlink 16

### \CONFIG.SYS

```
FILES=20
BUFFERS=48
DEVICE=\DOS\HIMEM.SYS
DEVICE=\DOS\EMM386.EXE RAM 1024
DOS=HIGH,UMB
DEVICE=\GEFNDIS\PROTMAN.DOS/I:\GEFNDIS
rem
rem The Ethernet Adapter and its device driver must first be installed
rem into your computer. Replace the string "<DIRECTORY>" in the
rem following DEVICEHIGH command with the directory which contains
rem the specified device driver for your Ethernet Adapter module.
rem
DEVICEHIGH=<DIRECTORY>\ELNK16.DOS
DEVICEHIGH=\GEFNDIS\GEFNDIS.DOS
```

### \AUTOEXEC.BAT

```
SET GSMCFG=C:\GSM\CFILES
```

```
rem Bind NDIS Drivers
\GEFNDIS\netbind
```

### \GEFNDIS\PROTOCOL.INI

```
[protocol manager]
  DRIVERVERNAME = PROTMAN$

[GEFNDIS]
  DRIVERVERNAME = GEFNDIS$
  BINDINGS = ELNK16.DOS
  MAX_RX_SIZE = 560
  NUM_RX_BUFS = 8

; Caution: Interrupt conflicts may arise when using default hardware
; configurations for many Ethernet Adapters. For example,
; interrupt IRQ3 is commonly used for the COM2 serial port
; and most Ethernet adapters.
;
; The following information must match the hardware configuration
; of the Ethernet Adapter as installed on your computer. Please
; modify this information as necessary.

[ELNK16.DOS]
  DRIVERVERNAME = ELNK16$
```

## 3Com Etherlink /MC

### \CONFIG.SYS

```
FILES=20
BUFFERS=48
DEVICE=\DOS\HIMEM.SYS
DEVICE=\DOS\EMM386.EXE RAM 1024
DOS=HIGH,UMB
DEVICE=\GEFNDIS\PROTMAN.DOS/I:\GEFNDIS
rem
rem The Ethernet Adapter and its device driver must first be installed
rem into your computer. Replace the string "<DIRECTORY>" in the
rem following DEVICEHIGH command with the directory which contains
rem the specified device driver for your Ethernet Adapter module.
rem
DEVICEHIGH=<DIRECTORY>\ELNKMC.SYS
DEVICEHIGH=\GEFNDIS\GEFNDIS.DOS
```

### \AUTOEXEC.BAT

```
SET GSMCFG=C:\GSM\CFILES
```

```
rem Bind NDIS Drivers
\GEFNDIS\netbind
```

### \GEFNDIS\PROTOCOL.INI

```
[protocol manager]
DRIVERNAME = PROTMAN$
```

```
[GEFNDIS]
DRIVERNAME = GEFNDIS$
BINDINGS = ETHERLINKMC
MAX_RX_SIZE = 560
NUM_RX_BUFS = 8
```

```
; Caution: Interrupt conflicts may arise when using default hardware
; configurations for many Ethernet Adapters. For example,
; interrupt IRQ3 is commonly used for the COM2 serial port
; and most Ethernet adapters.
```

```
; The following information must match the hardware configuration
; of the Ethernet Adapter as installed on your computer. Please
; modify this information as necessary.
```

```
[ETHERLINKMC]
DRIVERNAME = ELNKMC$
```

## Western Digital EtherCard PLUS, EtherCard PLUS Elite 16, EtherCard PLUS/A

### \CONFIG.SYS

```
FILES=20
BUFFERS=48
DEVICE=\DOS\HIMEM.SYS
DEVICE=\DOS\EMM386.EXE RAM 1024
DOS=HIGH,UMB
DEVICE=\GEFNDIS\PROTMAN.DOS/I:\GEFNDIS
rem
rem The Ethernet Adapter and its device driver must first be installed
rem into your computer. Replace the string "<DIRECTORY>" in the
rem following DEVICEHIGH command with the directory which contains
rem the specified device driver for your Ethernet Adapter module.
rem
DEVICEHIGH=\<DIRECTORY>\MACWD.DOS
DEVICEHIGH=\GEFNDIS\GEFNDIS.DOS
```

### \AUTOEXEC.BAT

```
SET GSMCFG=C:\GSM\CFILES
```

```
rem Bind NDIS Drivers
\GEFNDIS\netbind
```

### \GEFNDIS\PROTOCOL.INI

```
[protocol manager]
  DRIVERVERNAME = PROTMAN$

[GEFNDIS]
  DRIVERVERNAME = GEFNDIS$
  BINDINGS = MACWD_NIF
  MAX_RX_SIZE = 560
  NUM_RX_BUFS = 8

; Caution: Interrupt conflicts may arise when using default hardware
; configurations for many Ethernet Adapters. For example,
; interrupt IRQ3 is commonly used for the COM2 serial port
; and most Ethernet adapters.
;
; The following information must match the hardware configuration
; of the Ethernet Adapter as installed on your computer. Please
; modify this information as necessary.

[MACWD_NIF]
  DRIVERVERNAME = MACWD$
  irq = 3
  ramaddress = 0xd000
  iobase = 0x280
  receivebufsize = 1024
```

**Intel 82593**

## \CONFIG.SYS

```
FILES=20
BUFFERS=48
DEVICE=\DOS\HIMEM.SYS
DEVICE=\DOS\EMM386.EXE RAM 1024
DOS=HIGH,UMB
DEVICE=\GEFNDIS\PROTMAN.DOS/I:\GEFNDIS
rem
rem The Ethernet Adapter and its device driver must first be installed
rem into your computer. Replace the string "<DIRECTORY>" in the
rem following DEVICEHIGH command with the directory which contains
rem the specified device driver for your Ethernet Adapter module.
rem
DEVICEHIGH=<DIRECTORY>\I82593.DOS
DEVICEHIGH=\GEFNDIS\GEFNDIS.DOS
```

## \AUTOEXEC.BAT

```
SET GSMCFG=C:\GSM\CFILES
```

```
rem Bind NDIS Drivers
\GEFNDIS\netbind
```

## \GEFNDIS\PROTOCOL.INI

```
[protocol manager]
  DRIVERVERNAME = PROTMAN$

[GEFNDIS]
  DRIVERVERNAME = GEFNDIS$
  BINDINGS = MLM_NIF
  MAX_RX_SIZE = 560
  NUM_RX_BUFS = 8

; Caution: Interrupt conflicts may arise when using default hardware
; configurations for many Ethernet Adapters. For example,
; interrupt IRQ3 is commonly used for the COM2 serial port
; and most Ethernet adapters.
;
; The following information must match the hardware configuration
; of the Ethernet Adapter as installed on your computer. Please
; modify this information as necessary.

[MLM_NIF]
  DRIVERVERNAME = I82593$$
  IOADDRESS = 0x300
  INTERRUPT = 15
  DMACHAN0 = 6
  DMACHAN1 = 7
  INBUFFER(K) = 8
  OUTBUFFERS(K) = 3
```

## Xircom Pocket Adapter

### \CONFIG.SYS

```
FILES=20
BUFFERS=48
DEVICE=\DOS\HIMEM.SYS
DEVICE=\DOS\EMM386.EXE RAM 1024
DOS=HIGH,UMB
DEVICE=\GEFNDIS\PROTMAN.DOS/I:\GEFNDIS
rem
rem The Ethernet Adapter and its device driver must first be installed
rem into your computer. Replace the string "<DIRECTORY>" in the
rem following DEVICEHIGH command with the directory which contains
rem the specified device driver for your Ethernet Adapter module.
rem
DEVICEHIGH=<DIRECTORY>\PE2NDIS.EXE
DEVICEHIGH=\GEFNDIS\GEFNDIS.DOS
```

### \AUTOEXEC.BAT

```
SET GSMCFG=C:\GSM\CFILES
```

```
rem Bind NDIS Drivers
\GEFNDIS\netbind
```

### \GEFNDIS\PROTOCOL.INI

```
[protocol manager]
  DRIVERVERNAME = PROTMAN$

[GEFNDIS]
  DRIVERVERNAME = GEFNDIS$
  BINDINGS = XIRCOMNET
  MAX_RX_SIZE = 560
  NUM_RX_BUFS = 8

; Caution: Interrupt conflicts may arise when using default hardware
; configurations for many Ethernet Adapters. For example,
; interrupt IRQ3 is commonly used for the COM2 serial port
; and most Ethernet adapters.
;
; The following information must match the hardware configuration
; of the Ethernet Adapter as installed on your computer. Please
; modify this information as necessary.

[XIRCOMNET]
  DRIVERVERNAME = XIRCOM$
```

## SMC EtherCard PLUS, EtherCard PLUS Elite 16, EtherCard PLUS/A

### \CONFIG.SYS

```

FILES=20
BUFFERS=48
DEVICE=\DOS\HIMEM.SYS
DEVICE=\DOS\EMM386.EXE RAM 1024
DOS=HIGH,UMB
DEVICE=\GEFNDIS\PROTMAN.DOS/I:\GEFNDIS
rem
rem The Ethernet Adapter and its device driver must first be installed
rem into your computer. Replace the string "<DIRECTORY>" in the
rem following DEVICEHIGH command with the directory which contains
rem the specified device driver for your Ethernet Adapter module.
rem
DEVICEHIGH=\<DIRECTORY>\SMCMAC.DOS
DEVICEHIGH=\GEFNDIS\GEFNDIS.DOS

```

### \AUTOEXEC.BAT

```

SET GSMCFG=C:\GSM\CFILES

```

```

rem Bind NDIS Drivers
\GEFNDIS\netbind

```

### \GEFNDIS\PROTOCOL.INI

```

[protocol manager]
DRIVERNAME = PROTMAN$

```

```

[GEFNDIS]
DRIVERNAME = GEFNDIS$
BINDINGS = SMCMAC_NIF
MAX_RX_SIZE = 560
NUM_RX_BUFS = 8

```

```

; Caution: Interrupt conflicts may arise when using default hardware
; configurations for many Ethernet Adapters. For example,
; interrupt IRQ3 is commonly used for the COM2 serial port
; and most Ethernet adapters.
;

```

```

; The following information must match the hardware configuration
; of the Ethernet Adapter as installed on your computer. Please
; modify this information as necessary.

```

```

[SMCMAC_NIF]
DRIVERNAME = SMCMAC$
irq = 3
ramaddress = 0xd000
iobase = 0x280
receivebufsize = 1024

```



---

## Optimizing the GSM for Network Operation

There are two parameters in the [GEFNDIS] section of PROTOCOL.INI which can be adjusted to optimize the operation of your GSM. These parameters are described below.

### Note

Only experienced network personnel should change the values of these parameters. Setting the parameters to values other than the defaults could cause unpredictable operation of the GSM.

**NUM\_RX\_BUFS** Number of RX frame buffers. This is usually the number of simultaneous messages that can be received and processed by the GSM. Defaults to 8 buffers of size specified in **MAX\_RX\_SIZE**. This parameter may be increased to handle additional test frame processing or network station management responses. This parameter can be decreased to free up PC memory usage.

**MAX\_RX\_SIZE** Maximum RX frame buffer size. This is the largest frame which may be received by the GSM. Incoming data frames which exceed this size will be ignored. A zero-length response is returned when an incoming test frame is received which exceeds this size. Defaults to 560 bytes for Network GSM use.

*Appendix*  
*I*

*Forms*

---

---

Data forms have been provided in this appendix for your convenience in recording test and configuration data for each station.

Table I-1. MMS-Ethernet Station Configuration Data\*

**Configure a Series 90-70 MMS-Station Screen**

STATION\_NAME \_\_\_\_\_  
 STATION\_TYPE \_\_\_\_\_  
 LOAD\_TYPE \_\_\_\_\_  
 MAC\_ADDRES \_\_\_\_\_  
 COMMENTS \_\_\_\_\_

**Data Link Parameters Screen**

TX\_RING\_LEN \_\_\_\_\_ RX\_RING\_LEN \_\_\_\_\_

**Network Layer Parameters Screen**

NSAP \_\_\_\_\_ LSAP \_\_\_\_\_ FE

**Transport/Session Layer Screen**

MAX\_PDUSZ\_LOG2 \_\_\_\_\_ WINDOW\_SIZE \_\_\_\_\_  
 REF\_TIMEOUT \_\_\_\_\_ RETRAN\_COUNT \_\_\_\_\_  
 GIVEUP\_TIMEOUT \_\_\_\_\_ INACTIVE\_TIMEOUT \_\_\_\_\_  
 RETRAN\_TIMEOUT \_\_\_\_\_ WINDOW\_TIMEOUT \_\_\_\_\_  
 USE\_CHECKSUM \_\_\_\_\_ ACK\_DELAY\_TIME \_\_\_\_\_  
 SESSION\_TIMEOUT \_\_\_\_\_ TSAP \_\_\_\_\_ 0001

**Application Processes Screen**

MMS\_RESPONDER COMMON\_NAME \_\_\_\_\_  
 APT\_OBJ\_ID { \_\_\_\_\_ } AE\_QUAL \_\_\_\_\_  
 PSAP \_\_\_\_\_ SSAP \_\_\_\_\_  
 APPLICATION INTERFACE COMMON\_NAME \_\_\_\_\_  
 APT\_OBJ\_ID { \_\_\_\_\_ } AE\_QUAL \_\_\_\_\_  
 PSAP \_\_\_\_\_ SSAP \_\_\_\_\_

**Association Parameters Screen**

MAX\_RESP\_ASSOC \_\_\_\_\_ MAX\_APPL\_ASSOC \_\_\_\_\_

**Local Application DIB Screen**

AP\_COMMON NAME \_\_\_\_\_ STATION\_NAME \_\_\_\_\_  
 AP\_COMMON NAME \_\_\_\_\_ STATION\_NAME \_\_\_\_\_  
 AP\_COMMON NAME \_\_\_\_\_ STATION\_NAME \_\_\_\_\_  
 AP\_COMMON NAME \_\_\_\_\_ STATION\_NAME \_\_\_\_\_

**MMS Variable Names Screen**

VARIABLE NAME	DATA_TYPE	TYPE SIZE	REFERENCE				
			PFX	LOC	COUNT	BIT OFF	ARR
_____	_____	_____	_____	_____	_____	_____	_____
_____	_____	_____	_____	_____	_____	_____	_____
_____	_____	_____	_____	_____	_____	_____	_____
_____	_____	_____	_____	_____	_____	_____	_____
_____	_____	_____	_____	_____	_____	_____	_____

**Maximum MMS Message Size Screen**

MAX\_MMS\_MESSAGE\_SIZE \_\_\_\_\_

**System Parameters Screen**

BUFFER\_POOL\_1 Size \_\_\_\_\_ Allocation % \_\_\_\_\_  
 BUFFER\_POOL\_2 Size \_\_\_\_\_ Allocation % \_\_\_\_\_  
 BUFFER\_POOL\_3 Size \_\_\_\_\_ Allocation % \_\_\_\_\_  
 BUFFER\_POOL\_4 Size \_\_\_\_\_ Allocation % \_\_\_\_\_

\* This form does not list all parameters that can be configured with the GSM. It includes only those parameters that are commonly changed from their default values.

Table I-2. Foreign Device Station Configuration Data

**Configure a Station Screen**

STATION\_NAME \_\_\_\_\_  
STATION\_TYPE \_\_\_\_\_  
LOAD\_TYPE \_\_\_\_\_  
MAC\_ADDRESS \_\_\_\_\_

**Foreign Device Application Processes Screen**

COMMON\_NAME \_\_\_\_\_  
APT\_OBJ\_ID { \_\_\_\_\_ }  
AE\_QUAL \_\_\_\_\_  
PSAP \_\_\_\_\_  
SSAP \_\_\_\_\_  
TSAP \_\_\_\_\_  
NSAP \_\_\_\_\_

### Ethernet Network Test Data Sheet

	Init Node	Resp Node 1	Resp Node 2	Resp Node 3	Resp Node 4	Resp Node 5	Resp Node 6	Resp node 7	Acceptable Rate
User's Node Description									N/A
<b>&lt;&lt;&lt; Test Results &gt;&gt;&gt;</b>									
Node Address									N/A
Frames Sent/ Response Recvd									>3e6H
Response W/Err									0
No Response									< once / 40K frames
<b>&lt;&lt;&lt; Data Link Tallies &gt;&gt;&gt;</b>									
LSap Of1									0
MacErr									0
BufProb									0
TstRcvd									> 3e6H
TstResp									> 3e6H
<b>&lt;&lt;&lt; MAC Tallies &gt;&gt;&gt;</b>									
SQErr									0
MisdPack									0
RbufErr									0
LateColl									0
LostCarr									0
FRtry									0
<b>&lt;&lt;&lt; Exception Log &gt;&gt;&gt;</b>									
Event									Empty
Count									
Entry(s)									

# Appendix J

## *GENet System Manager Data Link Error Codes*

The GENet System Manager Data Link error codes are described in this appendix. The NDIS error codes used by the Network GSM and by the NDIS Protocol Manager are also described.

Table J - 1. GENet System Manager Data Link Error Codes

<b>Error Code</b>	<b>Description</b>
1	Too many LSAPs.
2	LSAP not registered.
3	DLI task not registered.
4	Out of buffers - dliact routine.
5	Out of buffers - dlideact routine.
6	Out of buffers - dlisend routine.
7	Out of buffers - dligetbuf routine. Restart GSM.
8	Bad return code - dxprec routine.
9	Command error - bus boot.
10	Command error - open window.
11	Open load file error.
12	Command error - boot data.
13	Command error - end of file.
14	Command error - sense.
15	Out of buffers - GrantBuf routine.
16	Bad type - GrantBuf routine.
17	Power on diagnostics error.
18	Power on diagnostics timeout.
19	MP400 busy - DXPsend routine.
20	Controller failed to enter run state.
21	In ring failed.
22	Hardware reset failed.
23	Send maintenance interface block timeout.
24	Maintenance interface block response error.
25	Send communication block timeout.
26	Bad input command.
27	Received communication block response timeout.
28	Communication block status error.
29	Unknown LSAP.
30	Receive data timeout.
31	Send data timeout.

**Table J-1 GENet System Manager Data Link Error Codes - Continued**

<b>Error Code</b>	<b>Description</b>
32	fmallocerror.
34	Deact error.
35	Recv error.
36	LSAP is active.
37	No act confirm.
38	No deact confirm.
39	Deact LSAP error.
40	Act error.
41	Post buffer error.
42	No send confirm.
43	Send error.
44	ProgrammedI/O timeout error.
45	GPIO Ready error. Restart LAN Interface.
46	Invalid LAN Interface type selection.
47-49	Reserved.
	Additional NDIS error code may be displayed for Data Link Error Codes 54-56; see Table B-2.
50	Error opening GEFNDIS driver.
51	Error closing GEFNDIS driver.
52	GEFNDIS device not open.
53	GEFNDIS driver not bound to MAC driver.
54	Error posting READ to GEFNDIS driver.
55	READ indication error from GEFNDIS driver.
56	Error WRITING TX frame to GEFNDIS driver.
57	WRITE confirm error from GEFNDIS driver.
58	No WRITE confirm from GEFNDIS driver.
59	Error during IOCTL READ to GEFNDIS driver.
60	IOCTL READ confirm error from GEFNDIS driver.
61	No IOCTL READ confirm from GEFNDIS driver.
62	Error during IOCTL WRITE to GEFNDIS driver.
63	IOCTL WRITE confirm error from GEFNDIS driver.
64	No IOCTL WRITE confirm from GEFNDIS driver.
65	NDIS MAC failure (Fatal Error). Restart PC.

Table J - 2. NDIS Error Codes

Error Code (hexadecimal)	Description
	NDIS Error Codes 0000-000D and xxFF may be returned with Data Link Error Codes 54-64. (*NDIS codes 0001-0005 are returned to the MAC. These codes should never be indicated by the GSM.)
0000	Success or no additional error information.
0001*	ReceiveChain is keeping RX buffer.
0002*	Request was queued.
0003*	Frame was not recognized.
0004*	Frame was rejected.
0005*	Forward RX frame to other protocol(s).
0006	MAC out of resources.
0007	Invalid parameter.
0008	Invalid function code.
0009	Function is not supported.
000A	Hardware error during request (non-fatal). (may indicate network disconnection)
000B	Transmit error; frame was not sent. (may indicate network disconnection)
000D	Buffer was too small.
00FF	General failure (non fatal). (may indicate network disconnection)
F1FF	GEFNDIS resource error
F2FF	GEFNDIS duplicate LSAP error
F3FF	GEFNDIS LSAP not found error
	NDIS Error Codes 0020-002F may be indicated during Protocol Manager installation (as PC is started) or when running Netbind utility. The error is displayed as PRONnnnE, where nnnn is the NDIS error code.
0020	Driver already started.
0021	Binding was not complete.
0022	Driver was not initialized.
0023	Interface hardware was not found.
0024	Interface hardware failure.
0025	Configuration failure.
0026	Hardware interrupt conflict.
0027	Incompatible MAC.
0028	Initialization failed.
0029	Binding did not occur.
002A	Network might not be connected.
002B	Incompatible DOS version.
002C	Driver is already registered.
002D	PROTMAN.DOS pathname incorrect.
002E	Insufficient DOS memory for PROTMAN.DOS to run.
002F	Cannot access PROTOCOL.INI image.



## A

Abbreviations and Acronyms, A-1  
Abort Indication Service, 6-20  
Abort Request Command – 8207, MMS  
COMM\_REQ, 6-20  
Abstract and Transfer Syntaxes Screen,  
8-18  
ACB. *See* Association Control Block  
ACB Command, Station Manager, 4-17  
Access Station Manager, Function in the  
GSM, 2-8  
Access Station Manager Screen, 3-42  
Access to the Station Manager on the  
Ethernet Interface, 1-4  
Accessing the Station Manager, 3-42  
Accessing the Station Manager from the  
Local PLC, 4-5  
Accessing the Station Manager Using an  
ASCII Terminal, 4-4  
Accessing the Station Manager Using the  
GSM, 4-3  
ACK\_DELAY\_TIME, 8-15  
ACN, 8-17  
ACN\_OBJ\_ID, 8-17  
Acronyms and Abbreviations, A-1  
ACSE Services, B-4  
ACSE Tallies (Tally e), 4-39  
Advanced Network, Definition, 8-1  
AE\_QUAL, 3-37 , 8-17  
ALL\_END\_SYSTEMS (ES) MAC\_AD-  
DRESS, 8-11  
ALL\_END\_SYSTEMSLSAP, 8-11  
ALL\_INTERMEDIATE\_SYSTEMS (IS)  
MAC\_ADDRESS, 8-11  
ALL\_INTERMEDIATE\_SYSTEMSLSAP,  
8-11  
alsap, 4-34  
Alt-H , 3-15  
Alt-K, 3-15  
applaequal, 4-34 , 8-17  
applapt, 4-34 , 8-16

applcnam, 3-28 , 4-34 , 8-16  
Application Entities, B-7  
Application Interface, 6-3  
Application Layer Parameters, F-1  
Application Layer Tallies (Tally a), 4-37  
ApplicationProcess, B-7  
ApplicationProcesses, 6-2  
ApplicationProcesses Screen, 3-28 , 8-16  
ApplicationService Elements, B-7  
applpsap, 3-29 , 4-34 , 8-17  
applssap, 3-29 , 4-34 , 8-17  
APT\_OBJ\_ID, 3-37 , 8-16  
arespaequal, 4-34 , 8-17  
arespapt, 4-34 , 8-16  
arespcnam, 4-34 , 8-16  
aresppsap, 3-29 , 4-34 , 8-17  
arespsap, 4-34 , 8-17  
Array Variables, 6-27  
assocappl, 4-34 , 8-19  
Association Control Block (ACB), 6-7  
AssociationParameters Screen, 8-19  
AssociationServices, 6-11  
Association Status Bits, 6-7  
Association Status Word, 6-9  
Association Status Word Extension, 6-10  
assocresp, 4-34 , 8-19  
Attachment of the Ethernet Interface to  
the LAN, 1-3  
AUI (Transceiver Cable), D-5  
AUI (Transceiver) Port, 2-4  
AUI Port for the Ethernet Interface, D-4  
AUI Port Pinouts, D-4  
AUTOEXEC.BAT, 3-7 , 3-8 , H-2  
AUTOEXEC.GSM, 3-8  
Automatic Routing, 8-13

## B

Backplane Online, E-2  
balloc1, 4-34

- balloc2, 4-34
  - balloc3, 4-34
  - balloc4, 4-34
  - Basic Network, Definition, 3-17
  - Battery, 2-4
  - bbuff1, 4-34
  - bbuff1-4, 8-26
  - bbuff2, 4-34
  - bbuff3, 4-34
  - bbuff4, 4-34
  - Bit String Data, B-28
  - Boolean Data, B-27
  - BPS Command, Station Manager, 4-17
  - bremlsap, 4-34 , 8-26
  - brepri, 4-34 , 8-26
  - BUFFER\_POOL, 8-26
- C**
- Cables
    - AUI Transceiver Cable, D-5
    - Serial, GSM to Ethernet Interface, D-2
  - Cancel Request Command – 8290, MMS COMM\_REQ, 6-61
  - CAP Command, Station Manager, 4-18
  - Capabilities of the Ethernet Interface, 1-2
  - Capability Objects, B-17
  - CFILES, 3-7
  - Changing the GSM Password Screen, 3-46
  
  - Changing the PC Network Card, 3-12
  - CHBPS Command, Station Manager, 4-18
  - CHDATE Command, Station Manager, 4-18
  - CHECK\_TIME, 8-11
  - CHLTIME Command, Station Manager, 4-19
  - CHSOSW Command, Station Manager, 4-19
  - CHTIME Command, Station Manager, 4-21
  
  - CLEAR Command, Station Manager, 4-22
  - Client–Server Model, B-10
  - CLSOSW Command, Station Manager, 4-22
  - COMM\_REQ, 5-2
    - See also* MMS COMM\_REQ; Station Manager COMM\_REQs
  - COMM\_REQ Status Word, 5-3
  - COMMON\_NAME, 3-28 , 3-37 , 8-16
  - Communications Ports Characteristics, D-1
  - Conclude Confirm Service, 6-19
  - Conclude Indication Service, 6-18
  - Conclude Request Command – 8205, MMS COMM\_REQ, 6-18
  - Conclude Response Command – 8206, MMS COMM\_REQ, 6-19
  - Conditions for Downloading a Station, 2-14
  - CONFIG.GSM, 3-8
  - CONFIG.SYS, 3-8 , H-2
  - CONFIG\_TIME, 8-10
  - Configuration Editor, 1-4
  - Configuration Editor Main Menu, 8-5
  - Configuration Editor Menu for Series 90–70 PLCs, 3-23
  - Configuration File for a Station, 3-20
  - Configuration Parameters via the Station Manager, F-1
  - Configuration Parameters, Station Manager, 4-34
  - Configure a Station Screen, 3-19 , 8-2
  - Configuring a Non–GE Fanuc Device, 3-35
  - Configuring a Series 90–70 PLC Station, 8-5
  - Configuring a Station, 2-13
  - Configuring a Station for a Basic Network, 3-17
  - Configuring and Downloading a Station, 2-13
  - Configuring the Ethernet Interface with Logicmaster 90–70, 2-12
  - Connecting the GSM to the LAN Interface, 3-3

Control Characters, Station Manager, 4-16  
 CRSW, 5-3  
 CTRL-K eys, 4-16

## D

Data Link Error Codes (GSM), J-1  
 Data Link Layer Parameters, F-3  
 Data Link Parameters Screen, 8-8  
 Data Link Tallies (part of Tally l), 4-39  
 DATA\_TYPE, 3-33 , 8-22  
 Date, 4-9  
 DATE Command, Station Manager, 4-23  
 DDP\_CONFLICT\_TIMEOUT, 8-27  
 DDP\_DISABLE, 8-27  
 DDP\_RESOLVE\_RETRIES, 8-27  
 Debugging. *See* Troubleshooting  
 Default Station Address Label, 2-4  
 Define Application Command – 8200, MMS COMM\_REQ, 6-67  
 Defining a Station, 8-3  
 Deleting a Station, 8-4  
 Deleting a Station Configuration File, 3-21  
  
 DESTINATION\_NSAP, 8-12  
 DISAB\_TX\_RTRY, 8-8  
 Discard InformationReport Indication Data Command – 8339, MMS COMM\_REQ, 6-38  
 Display Data Representation, 4-11  
 Display Terminal Settings, D-3  
 Distributed Directory Protocol (DDP) Tallies (Tally d), 4-38  
 DomainObjects, B-17  
 DOS System Files for Network Operation of the GSM, 3-8 , H-1  
 DOS VERSION, 3-8  
 Download Mode/Load Source, 2-15  
 Download Station Screen, 3-39  
 Downloader, 1-4

Downloading a Station, 2-14 , 3-39  
 Downloading a Station, Conditions, 2-14  
 Downloading Locally (Over the Serial Port), 3-39  
 Downloading Over the Network, 3-40

## E

Error Codes, Data Link, GENet System Manager, J-1  
 Error Codes, Exception Log Event , 9-10  
 Error Codes, Extended Status Buffer, 9-27  
 Error Codes, NDIS, J-3  
 Error Indication Service, 6-65  
 Error Request Command – 8350, MMS COMM\_REQ, 6-64  
 EtherCard PLUS, EtherCard PLUS Elite 16, EtherCard PLUS/A,H-5  
 Etherlink /MC, H-4  
 Etherlink 16, H-3  
 Etherlink ii, H-2  
 Ethernet Hardware Overview, 2-2  
 Ethernet Interface, 1-2 , 2-2  
   Attachment to the LAN, 1-3  
   Operational States, 2-9  
   Powering-Up, 2-10  
   Capabilities, 1-2  
 Ethernet Interface Installation, 2-5  
 Ethernet Interface, Powering-up, 2-8  
 Ethernet Software, 1-3  
 Event Log Format, Station Manager COMM\_REQs, 7-6  
 Examine Association Options Command – 8300, MMS COMM\_REQ, 6-21  
 Examine InformationReport Indication Variable Command – 8321, MMS COMM\_REQ, 6-36  
 Examine Initiate Indication Command – 8202, MMS COMM\_REQ, 6-13  
 Examine Last Error Information Command – 8352, MMS COMM\_REQ, 6-66  
 Examine Positive Initiate Confirm Command – 8204, MMS COMM\_REQ, 6-17

Examine Reject Indication Command –  
8351, MMS COMM\_REQ, 6-65

Examine Reset Indication Command –  
8311, MMS COMM\_REQ, 6-47

Examine Resume Indication Command –  
8314, MMS COMM\_REQ, 6-49

Examine Start Indication Command –  
8305, MMS COMM\_REQ, 6-41

Examine Stop Indication Command –  
8308, MMS COMM\_REQ, 6-44

Examine UnsolicitedStatus Indication  
Command – 8253, MMS  
COMM\_REQ, 6-56

Example Ladder Program, 2-22

Example PLC Ladder Program, Using the,  
2-22

Exception Log Event Codes, 4-26 , 9-10

Exit to DOS, 3-47

EXS Command, Station Manager, 4-23

Extended Status Buffer Data, 7-2

Extended Status Buffer Error Codes, 9-27

Extended Status Buffer Negative Values,  
9-27

## F

Field Network Test State, 9-6

Field Network Test Utility, 2-17 , 4-14  
Invoking, 2-17

Field Network Test Utility Commands,  
4-15

FIRST\_HOP\_LSAP, 8-12

FIRST\_HOP\_MAC\_ADDR, 8-12

FIRST\_HOP\_NSAP, 8-12

Floating Point, B-29

Foreign Device Application Processes  
Screen, 3-37

Foreign Device Configuration Editor  
Menu, 3-35

Forms, H-1

## G

Gateway, 8-1

GE Fanuc CNC AP Implementation, B-9

GEFNDIS directory, 3-8

GENet System Manager, 1-1 , 1-4

GENet System Manager Data Link Error  
Codes , J-1

Get Remote Name List Command – 8301,  
MMS COMM\_REQ, 6-62

GIVEUP\_TIMEOUT, 8-14

Glossary of Terms, A-1 , A-3

GSM, 1-1

GSM functions, 3-2

GSM Keyboard Functions, 3-15

GSM Main Menu, 3-13

GSM Menu Structure, 3-16

GSM Menus, 3-14

GSM Software, Updating, 3-12

GSM Support Functions, 3-43

GSM Using Local Connection, 2-8

GSM Using Network Connection, 2-8

GSM, Hardware Requirements, 3-5

GSM, Installing and Starting-Up , 3-4

## H

Hardware Requirements for the GSM, 3-5

HELP Command, Station Manager, 4-24

HOLDING\_TIME, 8-10

How to Make it Work, 1-5

## I

Identify Confirm Service, 6-60

Identify Request Command – 8240, MMS  
COMM\_REQ, 6-59

Implementation of the OSI Model in GE  
Fanuc Control Devices, B-4

INACTIVE\_TIMEOUT, 8-15

InformationReport Indication Service,  
6-35

- InformationReport Request Command – 8320, MMS COMM\_REQ, 6-34
  - Initialization Files, Sample DOS, H-2
  - Initiate Confirmation Service, 6-16
  - Initiate Indication Service, 6-12
  - Initiate Request Command – 8201, MMS COMM\_REQ, 6-11
  - Initiate Response Command – 8203, MMS COMM\_REQ, 6-15
  - Initiating the Download, 2-15
  - Installing and Starting-Up the GSM, 3-4
  - Installing the Ethernet Interface in the PLC, 2-5
  - Installing the PC Network Card, 3-5
  - Integers, B-29
  - Intel 82593, H-6
  - Introducton, 1-1
  - ISO Networking Concepts , B-1
  - ISO Parameters Menu, 3-23 , 3-25 , 8-7
  - ISO Protocols Implemented, B-3
- K**
- Keyboard Functions, GSM , 3-15
- L**
- Ladder Programming Tips, 5-9
  - Ladder Programs for Network Testing , G-1
  - LAN Interface Status Word, 5-7 , 9-30
  - LAN Online, E-2
  - ldrtry, 4-34 , 8-8
  - LEDs, 2-3 , 2-10 , 2-11
  - lgrpmsk0-7, 4-34 , 8-9
  - List All Configured Application DIBs Menu, 3-44
  - List All Stations Screen, 3-43
  - LISW, 5-7 , 9-30
  - LLC. *See* Data Link
  - lmacaddr, 4-34
  - lmaxdb, 4-34 , 8-8
  - LOAD Station Manager Command, 2-16
  - LOAD Command, Station Manager, 4-25
  - Load Group Parameters Screen, 8-30
  - Load Source, E-2
  - Load Source Parameters, 4-20
  - Load Source/Download Mode, 2-15
  - LOAD\_GROUP, 3-20 , 8-3
  - LOAD\_MULTICAST\_ADDR, 8-30
  - LOAD\_TYPE, 3-20 , 8-3
  - Loader State, 2-15 , 9-7
  - Loading a LAN Interface. *See* Downloading
  - Local Application DIB Screen, 3-30 , 8-20
  - Local Downloading, 2-15
  - Locating Applications, B-10
  - LOG Command, Station Manager, 4-25
  - Log Event Definitions, 4-26 , 9-10
  - Log event format, 9-8
  - LOGIN Command, Station Manager, 4-26
  - LOGOUT Command, Station Manager, 4-27
  - lrxringlen, 4-34 , 8-8
  - LSAP, 8-10 , 8-26
  - LTIME Command, Station Manager, 4-27
  - ltxringlen, 4-34 , 8-8
  - lxidtime, 4-34
- M**
- MAC Address, 2-15 , 3-20
  - MAC Address, Structure of, 3-21
  - MAC Layer Tallies (part of Tally I), 4-40
  - MAC\_ADDRESS, 3-20 , 8-3
  - maltacn, 4-34 , 8-17
  - maltacnobj, 4-34 , 8-17
  - Mapping MMS Services to ACSE and Presentation Services, B-4
  - MAX\_APPL\_ASSOC, 8-19
  - MAX\_DATA\_BUF, 8-8

- MAX\_MMS\_MESSAGE\_SIZE, 8-24
- MAX\_NPDU\_SIZE, 8-10
- MAX\_PDUSZ\_LOG2, 8-14
- MAX\_RESP\_ASSOC, 8-19
- Maximum MMS Message Size Screen, 8-24
- MDB, 5-2
- MDIB Command, Station Manager, 4-28
- Memory Access Services, 6-24
- Memory Pool Allocation Parameters, 8-25
- Menu Structure, 8-6
- Menus, GSM, 3-14
- Message Definition Block, 5-2
- Message Flow in the OSI Model, 6-2
- Miscellaneous OSI Services, 6-59
- mmaxmsgsz, 4-34 , 8-24
- MMS COMM\_REQ Command Descriptions, 6-11
- MMS COMM\_REQs
  - Abort Request Command – 8207, 6-20
  - Cancel Request Command – 8290, 6-61
  - Conclude Request Command – 8205, 6-18
  - Conclude Response Command – 8206, 6-19
  - Define Application Command – 8200, 6-67
  - Discard InformationReport Indication Data Command – 8339, 6-38
  - Error Request Command – 8350, 6-64
  - Examine Association Options Command – 8300, 6-21
  - Examine InformationReport Indication Variable Command – 8321, 6-36
  - Examine Initiate Indication Command – 8202, 6-13
  - Examine Last Error Information Command – 8352, 6-66
  - Examine Positive Initiate Confirm Command – 8204, 6-17
  - Examine Reject Indication Command – 8351, 6-65
  - Examine Reset Indication Command – 8311, 6-47
  - Examine Resume Indication Command – 8314, 6-49
  - Examine Start Indication Command – 8305, 6-41
  - Examine Stop Indication Command – 8308, 6-44
  - Examine UnsolicitedStatus Indication Command – 8253, 6-56
  - Get Remote Name List Command – 8301, 6-62
  - Identify Request Command – 8240, 6-59
  - InformationReport Request Command – 8320, 6-34
  - Initiate Request Command – 8201, 6-11
  - Initiate Response Command – 8203, 6-15
  - Read Request Command – 8322, 6-28
  - Reset Request Command – 8310, 6-46
  - Reset Response Command – 8312, 6-47
  - Resume Request Command – 8313, 6-48
  - Resume Response Command – 8315, 6-50
  - Set Local ProgramInvocation Processing – 8356, 6-51
  - Set Local ProgramInvocation State Command – 8355, 6-52
  - Set Local VMD Status Command – 8353, 6-57
  - Start Request Command – 8304, 6-40
  - Start Response Command – 8306, 6-42
  - Status Request Command – 8250, 6-53
  - Status Response Command – 8251, 6-54
  - Stop Request Command – 8307, 6-43
  - Stop Response Command – 8309, 6-45
  - Transfer InformationReport Indication Data Command – 8330, 6-37
  - Unsolicited Status Request – 8252, 6-55
  - Write Request Command – 8323, 6-31
- MMS COMMunications REQuests, 6-1
- MMS Error Encodings, 6-68
- MMS Objects and Their Attributes, B-11
- MMS Parameters, F-3
- MMS Parameters Menu, 3-23 , 3-31 , 8-21
- MMS Provider Tallies (Tally m), 4-40
- MMS Responder, 6-2
- MMS Variable Mapping, B-27
- mmsacn, 4-34 , 8-17
- mmsacnobj, 4-34 , 8-17
- Modify Commands, Station Manager , 4-8
- MODULE OK LED, 2-3

Monitor Commands, Station Manager, 4-7

Monochrome Monitor, Mode CO80 Command, 3-9

## N

Named Variables, 6-24

Naming and Addressing, B-30

ncfgtime, 4-35 , 8-10

nchksum, 4-35 , 8-11

NDIS Error Codes, J-3

NDIS-compliant, 3-8

neslsap, 4-35 , 8-11

nesmac, 4-35 , 8-11

NET Command, Station Manager, 4-28

Network Downloading, 2-16

Network Layer Parameters, F-4

Network Layer Parameters Screen, 3-26 , 8-10

Network Layer RIB Table Screen, 8-12

Network Layer Tallies (Tally n), 4-41

Network Load Address, E-2

Network-W ide Parameters, 8-29

Network-W ide Parameters Menu, 8-29

nhlldtime, 4-35 , 8-11

nislsap, 4-35 , 8-11

nismac, 4-35 , 8-11

nmaxpdu, 4-35 , 8-10

NODE Command, Station Manager, 4-29

noptmiz, 4-35 , 8-11

NPDU\_LIFETIME, 8-10

npdulife, 4-35 , 8-10

npriority, 4-35 , 8-10

nqwtime, 4-35 , 8-11

NSAP, 3-26 , 8-10

nsap, 4-35

ntick, 4-35 , 8-11

Numeric Addresses, 6-24

## O

Object Scope, B-12 , B-29

Octet Strings and Visible Strings, B-29

OK Command, Station Manager, 4-29

ONLINE LED, 2-3

Operational State, 9-8

Operator Station Objects (CNC Only), B-25

OPTIMIZE, 8-11

Optimizing the GSM for Network Operation, H-9

OSI Addressing, B-5

OSI Application Layer, 6-1 , B-7

OSI Reference Model, 6-1 , B-2

## P

PACKET\_PRIORITY, 8-10

pacsepci, 4-35

pacsesynnam, 4-35

pacsesynobj, 4-35

PASSWORD, 8-26

PC Network Card, Changing, 3-12 , H-1

PC Network Card, Installing, 3-5 , H-1

PC Network Cards

3Com, 3-5

Intel, 3-5

SMC/Western Digital, 3-5

Xircom, 3-5

PI Command, Station Manager, 4-29

PI Commands, 6-39

PICS for the Manufacturing Message Specification (MMS), C-1

PLC Driver Tallies (Tally c), 4-38

PLC Module Configuration, 2-12

pmmspici, 4-35

pmmsynnam, 4-35

pmmsynobj, 4-35

Ports

AUI, D-4

AUI, 2-4

Serial, 2-4

- Power-Up Problems, 2-11
- Power-up State, 9-5
- Powering-Up the Ethernet Interface, 2-8, 2-10
- Presentation Layer Parameters, F-4
- Presentation Layer Tallies (Tally p), 4-41
- Presentation Services, B-4
- Print File Menu, 3-24
- Print File Screen, 3-34, 8-28
- PRINT\_FILE\_NAME, 3-34, 8-28
- PRIORITY, 8-26
- Problems During PowerUp, 2-11
- Problems During the Download, 2-16
- Program Invocation Management Services, 6-39
- Program Invocation Objects, B-21
- Programming Communications COMM\_REQs, 6-5
- PROTMAN.xxx, 3-9
- Protocol Data Transfer, B-6
- PROTOCOL.GSM, 3-9
- PROTOCOL.INI, 3-9, H-1
- Protocols Used for GE Fanuc Control Devices, B-3
- PSAP, 3-29, 8-17
- pxferpci, 4-35
- pxfersynnam, 4-35
- pxfersynobj, 4-35
  
- Q**
- QUERY\_WAIT\_TIME, 8-11
- Quick Guide to the Manual, 1-6
  
- R**
- RAM Required, 3-5
- Read Confirm Service, 6-30
- Read Indication Service, 6-30
- Read Request Command – 8322, MMS COMM\_REQ, 6-28
- REF\_TIMEOUT, 8-14
- Reject Indication Service, 6-65
- REM Command, Station Manager, 4-30
- Remote Operation of the Station Manager, 4-4
- REPORT Command, Station Manager, 4-31
- Request Completion, 6-8
- Requirements for Installing the Ethernet Interface, 2-5
- Reset Indication Service, 6-46
- Reset Request Command – 8310, MMS COMM\_REQ, 6-46
- Reset Response Command – 8312, MMS COMM\_REQ, 6-47
- Restart Button, 2-3
- RESTART Command, Station Manager, 4-32
- Restart Ethernet Interface Request – 8103, Station Manager COMM\_REQ, 7-7
- Resume Indication Service, 6-49
- Resume Request Command – 8313, MMS COMM\_REQ, 6-48
- Resume Response Command – 8315, MMS COMM\_REQ, 6-50
- RETRAN\_COUNT, 8-14
- RETRAN\_TIMEOUT, 8-15
- Retrieve Extended Status Buffer Request – 8100, Station Manager COMM\_REQ, 7-2
- Retrieve Log Events Request – 8102, Station Manager COMM\_REQ, 7-6
- Retrieve Tallies Request – 8101, Station Manager COMM\_REQ, 7-4
- RIB Command, Station Manager, 4-32
- Router, 8-1
- Routing, 8-13
- RX\_RING\_LEN, 8-8
  
- S**
- Sample DOS System Files, H-1



- SAP, B-5
- Saving Changes Before Exiting the Configuration Editor Main Menu, 8-6
- Scalar Variables, 6-27
- Selecting a Station, 8-4
- Selecting the Application Process, 6-4
- Serial Cable, GSM to Ethernet Interface, D-2
- Serial Number Label, 2-4
- Serial Port, 2-4
- Serial Port for Local GSM Communications, D-2
- Serial Port Pinouts, D-2
- Serial Port Settings, D-2
- Series 90–70 PLC AP Implementation, B-8
- Service Access Point, B-5
- Session Layer Parameters, F-5
- Session Layer Tallies (Tally s), 4-41
- SESSION\_TIMEOUT, 8-15
- Set Download Mode Screen, 3-47
- Set Local ProgramInvocation Processing – 8356, MMS COMM\_REQ, 6-51
- Set Local ProgramInvocation State Command – 8355, MMS COMM\_REQ, 6-52
- Set Local VMD Status Command – 8353, MMS COMM\_REQ, 6-57
- Set Station Manager Mode Screen, 3-47
- Setup GSM Menu, 3-46
- 7–Layer Application DIB Screen, 3-45
- SHOW Command, Station Manager, 4-33
- Soft Switch Default Values for the Ethernet Interface, 4-21
- Soft Switch Entry State, 9-5
- Soft Switch Entry Utility, 4-12
- Soft Switch Entry Utility Commands, 4-13
- Soft Switch Parameters , E-1
- Soft Switch Settings, E-3
- Soft Switches, 3-3
- SOSW Command, Station Manager, 4-36
- SQE, 2-6 , 4-40 , 9-22
- SRTP Parameters, F-6
- SRTP Service Agent Tallies (Tally v), 4-42
- SSAP, 3-29 , 8-17
- Start Indication Service, 6-41
- Start Request Command – 8304, MMS COMM\_REQ, 6-40
- Start Response Command – 8306, MMS COMM\_REQ, 6-42
- Starting–Up the GSM, 3-13
- STAT Command, Station Manager, 4-36
- States of the Ethernet Interface, 2-9
- Static Routing, 8-13
- Station Address, E-1
- Station Configuration File, Deleting, 3-21
- Station Configuration File, Selecting, 3-21
- Station Configuration Parameters , F-1
- Station Manager
  - ACB Command, 4-17
  - Accessing, 4-2
  - Accessing the Station Manager Using an ASCII Terminal, 4-4
  - BPS Command, 4-17
  - CAP Command, 4-18
  - CHBPS Command, 4-18
  - CHDATE Command, 4-18
  - CHLTIME Command, 4-19
  - CHSOSW Command, 4-19
  - CHTIME Command, 4-21
  - CLEAR Command, 4-22
  - CLSOSW Command, 4-22
  - DATE Command, 4-23
  - EXS Command, 4-23
  - HELP Command, 4-24
  - LOAD Command, 4-25
  - LOG Command, 4-25
  - LOGIN Command, 4-26
  - LOGOUT Command, 4-27
  - LTIME Command, 4-27
  - MDIB Command, 4-28
  - NET Command, 4-28
  - NODE Command, 4-29
  - OK Command, 4-29
  - PI Command, 4-29
  - REM Command, 4-30
  - Remote Operation of, 4-4
  - REPORT Command, 4-31
  - RESTART Command, 4-32
  - RIB Command, 4-32

- Services, 4-1
  - SHOW Command, 4-33
  - SOSW Command, 4-36
  - STAT Command, 4-36
  - STOPT Command, 4-37
  - TALLY Command, 4-37
  - TEST Command, 4-43
  - TIME Command, 4-44
  - TRACE Command, 4-45
  - Using the Station Manager, 4-6
  - VAR Command, 4-47
  - VMD Command, 4-47
  - Station Manager COMM\_REQs
    - Restart Ethernet Interface Request – 8103, 7-7
    - Retrieve Extended Status Buffer Request – 8100, 7-2
    - Retrieve Log Events Request – 8102, 7-6
    - Retrieve Tallies Request – 8101, 7-4
  - Station Manager Command Descriptions, 4-16
  - Station Manager Command Lists, 4-7 , 4-9
  - Station Manager Command Syntax, 4-10
  - Station Manager Configuration Parameters, 4-34
  - Station Manager Control Characters, 4-16
  - Station Manager in Utility Programs, 4-12
  - Station Manager Ladder Requests, 7-1
  - STATION\_NAME, 3-20 , 8-3
  - STATION\_TYPE, 3-20 , 8-3
  - Status Confirm Service, 6-55
  - Status Indication Service, 6-54
  - STATUS OK LED, 2-3
  - Status Request Command – 8250, MMS COMM\_REQ, 6-53
  - Status Response Command – 8251, MMS COMM\_REQ, 6-54
  - Status Services, 6-53
  - stime, 4-35 , 8-15
  - Stop Indication Service, 6-43
  - Stop Request Command – 8307, MMS COMM\_REQ, 6-43
  - Stop Response Command – 8309, MMS COMM\_REQ, 6-45
  - STOPT Command, Station Manager, 4-37
  - stsap, 4-35 , 8-15
  - SymbolicAddresses, 6-26
  - SYNTAX\_OBJ\_ID, 8-18
  - System Memory Tallies (Tally b), 4-38
  - System Parameters, F-2
  - System Parameters Menu, 3-24
  - System Parameters Screen, 8-25
- ## T
- Tallies Structure and Offsets, Station Manager COMM\_REQ, 7-5
  - TALLY Command, Station Manager, 4-37
  - Task Identification, 4-10
  - tchksum, 4-35 , 8-15
  - 10Base5, D-6
  - Terms, Glossary, A-3
  - TEST ALL Station Manager command, 2-21
  - TEST Command, Station Manager, 4-43
  - TEST Station Manager command, 2-17 , 2-19 , 2-20
  - Testing the Interfaces on the Network, 2-17
  - Testing the Network, Ladder Programs, G-1
  - tflowctrl, 4-35
  - tgiveup, 4-35 , 8-14
  - Time, 4-9
  - TIME Command, Station Manager, 4-44
  - tinactive, 4-35 , 8-15
  - tlcack, 4-35 , 8-15
  - tmaxpdu, 4-35 , 8-14
  - TRACE Command, Station Manager, 4-45
  - Transceiver, 9-22
  - Transceiver Cable. *See* AUI
  - Transceiver Description, D-6
  - Transfer InformationReport Indication Data Command – 8330, MMS COMM\_REQ, 6-37
  - Transport / Session Layer Parameters Screen, 3-27 , 8-14

Transport Layer Parameters, F-5  
Transport Layer Tallies (Tally t), 4-42  
treftime, 4-35 , 8-14  
Troubleshooting , 9-1  
trtrancnt, 4-35 , 8-14  
trtrantime, 4-35 , 8-15  
TSAP, 3-27 , 8-15  
Tuning and Configuring Stations for Advanced Networks, 8-1  
twindow, 4-35 , 8-15  
twindowsize, 4-35 , 8-14  
TX\_RING\_LEN, 8-8  
TYPE\_SIZE, 3-33

## U

Unconstrained Addresses, 6-26  
Unnamed Variables, 6-24  
Unsolicited Status Indication Service, 6-56  
Unsolicited Status Request – 8252, MMS COMM\_REQ, 6-55  
Updating Existing GSM Software, 3-12  
USE\_CHECKSUM, 8-15  
USE\_CHECKSUMS, 8-11  
User Elements, B-7  
Using the GSM Access Station Manager Function, 2-8  
Using the Monitor Commands, 4-7  
Using the Station Manager, 4-6

## V

VAR Command, Station Manager, 4-47  
Variable Names Screen, 3-32 , 8-22  
Variable Objects, B-24  
VARIABLE\_NAME, 3-32 , 8-22  
vdpcdisab, 4-35 , 8-27  
vdpretry, 4-35 , 8-27  
vdptmout, 4-35 , 8-27  
Verifying Proper Power-Up of the Interface, 2-8  
Virtual Manufacturing Device (VMD) Object, B-12  
VMD Attributes, B-12  
VMD Command, Station Manager, 4-47  
VMD Logical Status, B-15  
VMD Physical Status, B-15  
VMD Status Attributes, B-14  
vtsap, 4-35

## W

WINDOW\_SIZE, 8-14  
WINDOW\_TIMEOUT, 8-15  
Write Confirm Service, 6-33  
Write Indication Service, 6-32  
Write Request Command – 8323, MMS COMM\_REQ, 6-31

## X

Xircom Pocket Adapter, H-7