

GFK-0412

[Buy GE Fanuc Series 90-30 NOW!](#)

GE Fanuc Manual Series 90-30

Genius Communications Module

1-800-360-6802

sales@pdfsupply.com



GE Fanuc Automation

Programmable Control Products

*Series 90[™] -30
Genius[®] Communications Module*

User's Manual

GFK0412B

August 1997

Warnings, Cautions, and Notes as Used in this Publication

Warning

Warning notices are used in this publication to emphasize that hazardous voltages, currents, temperatures, or other conditions that could cause personal injury exist in this equipment or may be associated with its use.

In situations where inattention could cause either personal injury or damage to equipment, a Warning notice is used.

Caution

Caution notices are used where equipment might be damaged if care is not taken.

Note

Notes merely call attention to information that is especially significant to understanding and operating the equipment.

This document is based on information available at the time of its publication. While efforts have been made to be accurate, the information contained herein does not purport to cover all details or variations in hardware or software, nor to provide for every possible contingency in connection with installation, operation, or maintenance. Features may be described herein which are not present in all hardware and software systems. GE Fanuc Automation assumes no obligation of notice to holders of this document with respect to changes subsequently made.

GE Fanuc Automation makes no representation or warranty, expressed, implied, or statutory with respect to, and assumes no responsibility for the accuracy, completeness, sufficiency, or usefulness of the information contained herein. No warranties of merchantability or fitness for purpose shall apply.

The following are trademarks of GE Fanuc Automation North America, Inc.

Alarm Master	Field Control	Modelmaster	Series One
CIMPLICITY	GEnet	PowerMotion	Series Six
CIMPLICITY Control	Genius	ProLoop	Series Three
CIMPLICITY PowerTRAC	Genius PowerTRAC	PROMACRO	VuMaster
CIMPLICITY 90-ADS	Helpmate	Series Five	Workmaster
CIMSTAR	Logicmaster	Series 90	

This book describes the features, installation, and operation of the Series 90™ -30 Genius Communications Module.

Contents of this Manual

This book contains the following chapters:

Chapter 1. Introduction: describes the capabilities and appearance of the Genius Communications Module and lists its specifications.

Chapter 2. Hardware Installations: explains how to install or remove a Genius Communications Module and how to remove and replace the module's Terminal Assembly. This chapter also explains how to choose and install the bus cable, and how to install an optional connector for a Genius Hand-held Monitor.

Chapter 3. Operation and Timing: explains how the GCM sends, receives, and allocates Global Data. It also describes how other devices on the bus handle GCM Global Data and explains how to estimate the bus scan time contribution of the GCM.

Chapter 4. Configuration: describes the module's selectable features and summarizes configuration steps for a Hand-held Programmer.

Appendix A. Characteristics of the Genius Bus.

Appendix B. Comparison of the GCM and GCM+.

Changes in This Version of the Manual

This manual has been extensively revised and reorganized. Major changes include:

1. General information about the GCM+ module and Series 90-30 Genius Bus Controller has been added.
2. Information on operation and timing considerations is now combined in one chapter.
3. A section on compatibility has been added.
4. Information on bus cable types has been updated and expanded.
5. Information on bus installation has been expanded.
6. Instructions have been added for installing an optional Genius Hand-held Monitor connector.
7. The module configuration chapter has been restructured to include Hand-held Programmer configuration steps with enhanced parameter definitions.
8. An appendix detailing the electrical characteristics of the bus has been added.
9. Another appendix comparing the GCM and GCM+ modules has also been added.

Related Publications

For more information, refer to the following publications:

Series 90-30 Installation and Operation Manual (GFK-0356): This manual is the primary reference for information about the Series 90-30 PLC.

Hand-held Programmer User's Manual (GFK-0402): This book describes the Hand-held Programmer displays, and explains operator procedures for module configuration, programming, and data monitoring.

Logicmaster 90-30 Software User's Manual: This manual explains how to use the Logicmaster 90-30 software for programming and configuring a Series 90-30 PLC.

Genius I/O System User's Manual (GEK-90486-1): Reference manual for system designers, programmers, and others involved in integrating Genius I/O products in a PLC or host computer environment. This book provides a system overview, and describes the types of systems that can be created using Genius products. Datagrams, Global Data, and data formats are defined.

We Welcome Your Comments and Suggestions

At GE Fanuc automation, we strive to produce quality technical documentation. After you have used this manual, please take a few moments to complete and return the Reader's Comment Card located on the next page.

Jeanne Grimsby
Senior Technical Writer

Chapter 1

Introduction

The Series 90™-30 Genius Communications Module (IC693CMM301) is an intelligent module that provides automatic, “global data” communications between a Series 90-30 PLC and up to 7 other devices on a Genius bus.

Global Data is data that is transmitted automatically and repeatedly, allowing the formation of a shared database. A Genius Communications Module can exchange up to a total of 256 bits (32 bytes) of Global Data.

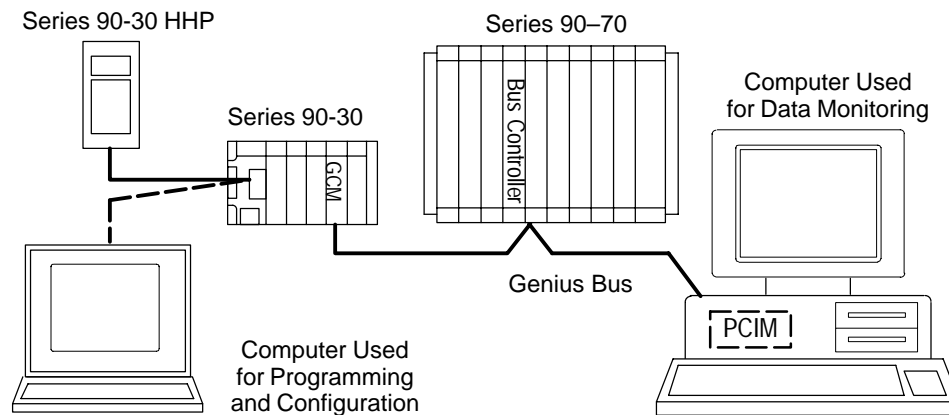

The illustration above represents a Series 90-30 PLC with a Genius Communications Module that can exchange Global Data with a Series 90-70 PLC and a computer equipped with a PCIM card. The diagram also shows a Hand-held Programmer and a computer, both of which can be used to configure the Series 90-30 PLC and GCM. The GCM can monitor input data from I/O devices; however, it cannot control I/O devices.

Other Genius Options for the Series 90-30 PLC

There are two other Genius modules for the Series 90-30 PLC:

- The Enhanced Genius Communications Module (GCM+). The GCM+ can exchange up to 128 bytes of Global Data with up to 30 other devices on the bus. The GCM+ provides diagnostics information and can potentially operate without a host PLC program. The GCM+ module cannot be installed in the same Series 90-30 PLC as a GCM module. See appendix B for a comparison of the features of the GCM and GCM+.
- The Series 90-30 Genius Bus Controller. The Bus Controller can exchange up to 128 bytes of Global Data and/or I/O control data. It can be used to interface the Series 90-30 PLC to Genius I/O Blocks, Remote Drops, and Field Control I/O Stations, as well as other types of controllers. A Bus Controller cannot be installed in the same Series 90-30 PLC as a GCM module.

Chapter 1	Introduction	1-1
	Module Description	1-2
	LEDs	1-2
	Specifications	1-3
	Compatibility	1-3
 Chapter 2	 Hardware Installation	 2-1
	Module Installation and Removal	2-1
	Module Installation	2-1
	Module Removal	2-2
	Terminal Assembly Removal and Installation	2-3
	Bus Cable Selection	2-5
	Using Other Cable Types	2-6
	Bus Length	2-6
	Baud Rate Selection	2-6
	Bus Installation	2-7
	Wiring Guidelines	2-9
	Lightning Transient Suppression	2-9
	Installing a Hand-held Monitor Connector	2-10
 Chapter 3	 Operation and Timing	 3-1
	Global (%G) Memory in the Series 90-30 PLC	3-2
	How the Devices on the Bus Handle GCM Global Data	3-4
	Timing Considerations	3-7
	Estimating Bus Scan Time	3-7
	Relationship Between the Bus Scan and the CPU Sweep	3-8
	Estimating Data Response Time	3-11
	Bus Scan Time (Tbus)	3-11
	Program Execution Time (Tcpu)	3-11
	Sending Data in Reply to Global Data Received	3-11
 Chapter 4	 Configuration	 4-1
	Configuration Planning	4-1
	Configurable Features	4-2
	Slot Number	4-3
	Device Number	4-3
	Baud Rate	4-4
	Global Data Length	4-5

Contents

Appendix A	Characteristics of the Genius Bus	A-1
	Electrical Interface	A-2
	Serial Bus Waveforms	A-4
	Effect of Long Cables, Repeaters, or Unspecified Cable Types on Maximum Length Bus	A-5
	Serial Data Format	A-6
	Bus Access	A-7
	Bus Errors Caused by Noise	A-7
Appendix B	Comparison of the GCM and GCM+	B-1

Module Description

The Genius Communications Module is a standard Series 90-30 PLC module. It plugs easily into the PLC's backplate. The latch on the bottom of the module secures it in position.

The module's Terminal Assembly, with its protective hinged cover, is removable. Bus connections are made to the Terminal Assembly and routed out through the bottom. The Terminal Assembly can be removed without breaking the bus and disrupting Genius communications if appropriately installed as described in chapter 2.

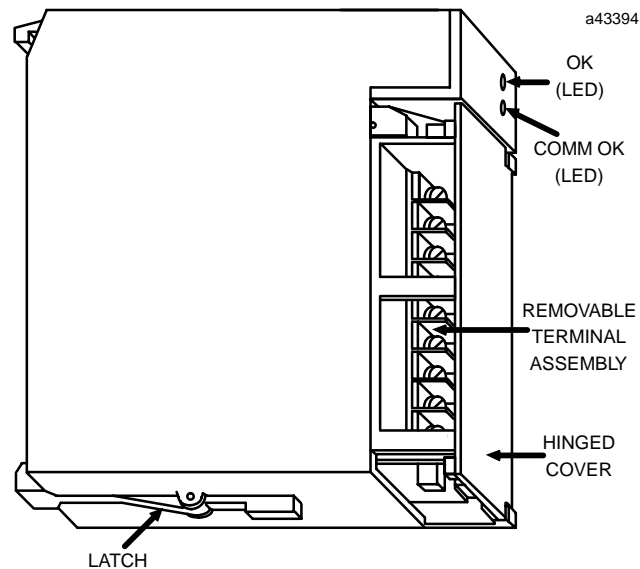

There are no DIP switches or jumpers to set on the module. Its configuration is completed using the Hand-held Programmer or system programming software.

LEDs

LEDs on the front of the Genius Communications Module indicate its operating status, and the status of communications between the module and the Series 90-30 PLC.

- OK** indicates that the module has passed its powerup test and is operating.
- COM** indicates that the Series 90-30 PLC has initialized the module, and that the module is receiving communications from the bus.

After successful startup, COM should remain ON unless an excessive number of communications errors occur. Ten errors in ten seconds, caused by noise on the bus, improper wiring, baud rate conflict, or Device Number conflict will cause COM to blink.

Specifications

Ordering Information	IC693CMM301, -304
Module Type	Series 90-30 PLC module, providing Global Data communications with up to 7 other PLCs.
LEDs	OK, COM
Global Data Length:	
per Communications Module	Up to 256 bits, configurable in 32-bit increments.
per Series 90-30 PLC	Up to maximum available %G memory
Environmental:	
Operating Temperature	0°C to +60°C (+32 °F to +140°F)
Storage Temperature	-25 °C to +70°C (-13 °F to +158°F)
Humidity	5% to 95% (non-condensing)
Vibration and Shock	0.2 inch displacement 5Hz to 10Hz 1 G 10Hz to 200Hz 5 G 10Ms duration

Compatibility

- Series 90-30 PLC** **Remote Racks:** Genius Communications Modules that are version IC697CMM301F/304F or later can be located in a remote rack. Earlier module versions can be upgraded for this purpose using Upgrade Kit: 44A286397-G03.
- PLC CPU:** Genius Communications Modules that are version IC697CMM301E/304E or earlier are not compatible with PLC CPU models: IC693CPU311H, -321H, and -331J or later. They can be upgraded using Upgrade Kit: 44A286397-G03.
- Bus Controllers** This module is compatible with any Bus Controller, PCIM, or QBIM *on the bus*, except Series Six™ Bus Controller models IC66*CBB900, -901, -902E or earlier, or -903E or earlier. The GCM cannot be installed in the same Series 90-30 PLC as a Series 90-30 Genius Bus Controller.
- Enhanced Genius Communications Module (GCM+)** The GCM cannot be installed in the same Series 90-30 PLC as an Enhanced Genius Communications Module (GCM+).
- Genius Hand-held Monitor** A Genius Hand-held Monitor can be used to display: the GCM Bus Address, its software version, and the Series Six register address configured for global data. HHM version IC660HHM501H (rev. 4.5) or later is required. There is no Hand-held Monitor connector on the GCM module, but a Hand-held Monitor may communicate with the GCM while connected to any other device on the bus. Optionally, an additional HHM mating connector can be installed on the bus near the GCM.
- Genius I/O Blocks** Genius I/O blocks may be present on the same bus. However, the GCM is *not* compatible with older “phase” A blocks; they should not be installed on the same bus.

Chapter 2

Hardware Installation

This chapter explains how to:

- install and remove a Genius Communications Module
- remove and install the module's Terminal Assembly
- select and install the Bus Cable
- connect and terminate the communications bus
- plan system wiring installation and protect against lightning surges
- install a separate Genius Hand-held Monitor connector on the bus

Module Installation and Removal

The Genius Communications Module may be installed and removed in the same manner as all other Series 90-30 modules. Power must be OFF when installing or removing the module.

Module Installation

To install the Genius Communications Module in the Series 90-30 PLC backplate:

1. Grasp the module with the terminal board toward you and the rear hook facing away from you.
2. Align the module with the desired base slot and connector. Tilt the module upward so that the top rear hook on the module engages the slot on the baseplate.
3. Swing the module downward until the connectors mate and the locking lever on the bottom of the module snaps into place, engaging the baseplate notch.

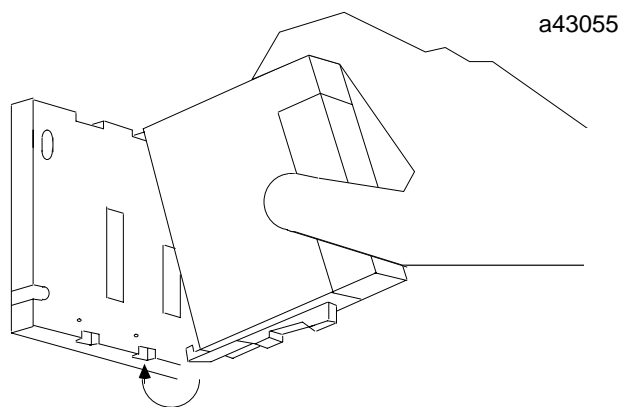

Note the slot number; this number must be entered when the module is configured.

Module Removal

The module can be removed without powering down the communications bus, provided the incoming and outgoing Serial 1 wires have been connected to one terminal and the Serial 2 wires have been connected to one terminal. If this has been done, do not disconnect the bus cable or any terminating resistor. Remove the Terminal Assembly from the front of the Genius Communications Module carefully. Avoid contact with exposed cable wiring. Place the Terminal Assembly, with the bus wiring still attached, in a protected location.

Caution

If exposed wiring comes in contact with conductive material, data on the bus may be corrupted, possibly causing the system to shut down.

If the rest of the bus is powered down, the bus wiring can be removed from the module.

To remove the module:

1. Locate the release lever on the bottom of the module. Firmly press it up toward the module.
2. While holding the module firmly at the top, continue fully depressing the release lever and swing the module upward.
3. Disengage the hook at the top of the module by raising the module up and moving it away from the baseplate.

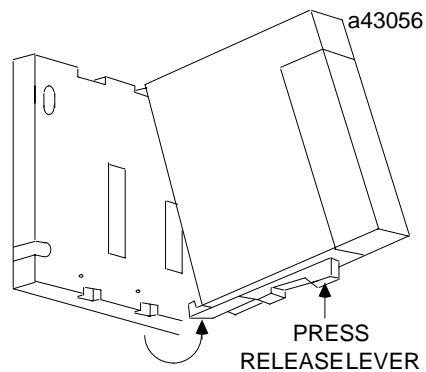

Terminal Assembly Removal and Installation

The Terminal Assembly of all Series 90-30 modules can be removed or installed from the module as described below.

Terminal Assembly Removal

1. Open the hinged cover on the front of the module.
2. There is a jacking lever above the wiring terminals, on the left. Push this lever upward to release the terminal block.

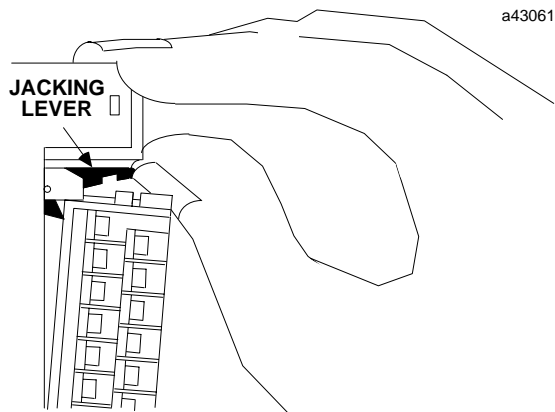

3. Grasp the narrower pull-tab located at the right of the retaining tab. Pull the tab toward you until the contacts have separated from the module housing and the hook has disengaged.

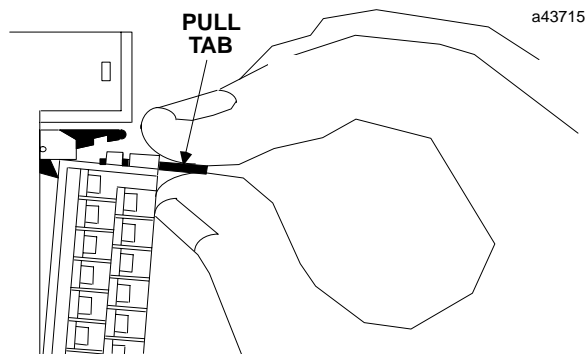

Terminal Assembly Installation

To replace the Terminal Assembly, follow the steps below. If wiring is already in place, be sure that the Terminal Assembly is being connected to the proper type of module.

Caution

Check the label on the hinged door and the label on the module to be sure they match. If a wired Terminal Assembly is installed on the wrong module type, damage to the module may result.

1. If the pull tab at the top of the Terminal Assembly is extended, push it back. Close the Terminal Assembly door.
2. Place the hook at the bottom of the Terminal Assembly into the corresponding slot at the bottom of the module.
3. Pivot the Terminal Assembly upward and firmly press it into position.
4. Open the door and check to be sure that the latch is securely holding the Terminal Assembly in place.

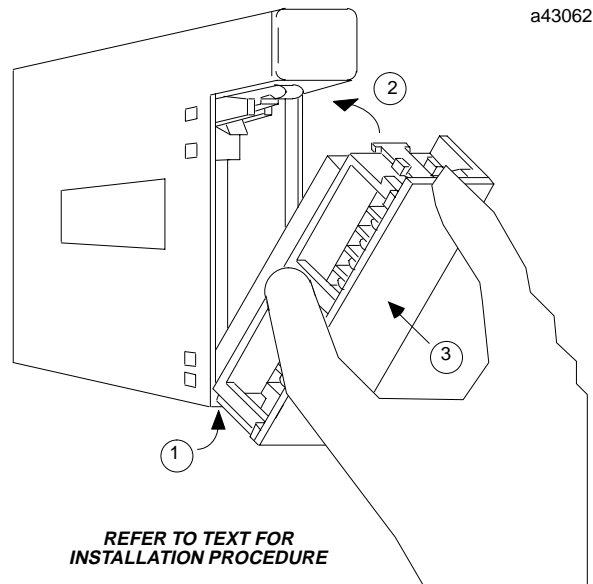

Bus Cable Selection

The Genius bus is a shielded twisted-pair wire, daisy-chained from block to block and terminated at both ends. Proper cable selection is critical to successful operation of the system.

Each bus in the system can be any cable type listed in the table below. Do not mix cables of different impedance, regardless of cable run length. Do not mix cable types in long and/or noisy installations. Other, small-size twisted pair shielded wire of unspecified impedance can be used for short runs of 50 feet or less, using 75 ohm terminations. Selection of wire type may be limited by local and national codes and industry standards. Consult the cable manufacturer to determine the cable's suitability for a particular type of installation.

Conservative wiring practices and national and local codes require physical separation between control circuits and power distribution or motor power. Refer to sections 430 and 725 of the National Electric Code. Also refer to Appendix A for more detailed information about the bus.

Cable # & Make	NEC (USA) Type	Outer Diameter	Terminating Resistor* -10%to+20% 1/2 Watt	Number of Conductors/ AWG	Dielectric Voltage Rating	Ambient Temp Rating	Maximum Length Cable Run, feet/meters at baudrate			
							153.6s	153.6e	76.8	38.4 ●
(A)9823 (C)4596 (M)M39240	none CL2 CM	.350in 8.89mm	150 ohms	2 / #22	30v	60C	2000ft 606m	3500ft 1061m	4500ft 1364m	7500ft 2283m
(B)89182	CL2P	.322in 8.18mm	150 ohms	2 / #22	150v	200C	2000ft 606m	3500ft 1061m	4500ft 1364m	7500ft 2283m
(B)9841 (M)M3993	CM CL2	.270in 6.86mm	120 ohms	2 / #24	30v	80C	1000ft 303m	1500ft 455m	2500ft 758m	3500ft 1061m
(A)9818C (B)9207 (M)M4270	CL2 CM CM	.330in 8.38mm	100 ohms	2 / #20	300v	80C	1500ft 455m	2500ft 758m	3500ft 1061m	6000ft 1818m
(A)9109 (B)89207 (C)4798 (M)M44270	CL2P CM * CMP	.282in 7.16mm	100 ohms	2 / #20	150v	200C	1500ft 455m	2500ft 758m	3500ft 1061m	6000ft 1818m
(A)9818D (B)9815	none *	.330in 8.38mm	100 ohms	2 / #20			1500ft 455m	2500ft 758m	3500ft 1061m	6000ft 1818m
(O)911264 **	none	.260in 6.60mm	100 ohms	2 / #22 flexing	250V	80C	1500ft 455m	2000ft 606m	3000ft 909m	4500ft 1364m
(E)532185 BBDN	CM	approx. .50in (12.7mm)	100 ohms	4 pairs #24 (solid)	>150V	80C	1500ft 455m	2000ft 606m	3000ft 909m	4500ft 1364m
(A)9818 (B)9855 (M)M4230	* CM CM	.315in 8.00mm	100 ohms	4 (two pair) #22	150v	60C	1200ft 364m	1700ft 516m	3000ft 909m	4500ft 1364m
(A)9110 (B)89696 (B)89855	none CMP CMP	.274in 6.96mm	100 ohms	4 (two pair) #22	150v	200C	1200ft 364m	1700ft 516m	3000ft 909m	4500ft 1364m
(A)9814C (B)9463 (M)M4154	none CM CL2	.243in 6.17mm	75 ohms	2 / #20	150v	60C	800ft 242m	1500ft 455m	2500ft 758m	3500ft 1061m
(A)5902C (B)9302 (M)M17002	none CM CM	.244in 6.20mm	75 ohms	4 (two pair) #22	300v	80C	200ft 60m	500ft 152m	1200ft 333m	2500ft 758m

Notes: A = Alpha, B = Belden, C = Consolidated, E = Essex, M = Manhattan, O = Olflex
 ● = Limited to 16 taps at 38.4 Kbaud
 * = not known
 ** = Suitable for applications requiring high flexibility continuous flex or vibration.

NEC classes are based on data obtained from manufacturers and are subject to change. CANADIAN CEC codes are generally similar. Other countries may vary. The serial bus can be treated as a Class 2 circuit when appropriate wiring practices are followed. Maximum available bus lengths may be affected when installation requires the high voltage rated CM (Communications) rating. CM types can replace CL2, but not vice versa.

Using Other Cable Types

The cable types listed in the preceding table are recommended for use. If the cable types listed above are not available, the cable selected must meet the following guidelines.

1. High quality construction. Most important is uniformity of cross section along the length of the cable. Poor quality cable may cause signal distortion, and increase the possibility of damage during installation.
2. Precision-twisted shielded wire of EIA RS422 standard type, having a uniform number of twists per unit of length. In a catalog, this type of cable may also be listed as twinaxial cable, data cable, or computer cable.
3. Relatively high characteristic impedance; 100 to 150 ohms is best; 75 ohms is the minimum recommended.
4. Low capacitance between wires, typically less than 20pF/foot (60pF/meter). This may be accomplished by inner dielectrics of foamed type, usually polypropylene or polyethylene, having a low dielectric constant. Alternatively, the conductors may be spaced relatively far apart. Lower impedance types have smaller cross-sections, and provide easier wiring for shorter total transmission distances.
5. Shield coverage of 95% or more. Solid foil with an overlapped folded seam and drain wire is best. Braided copper is less desirable; spiral wound foil is least desirable.
6. An outer jacket that provides appropriate protection, such as water, oil, or chemical resistance. While PVC materials can be used in many installations, Teflon, polyethelene, or polypropylene are usually more durable.
7. Electrical characteristics: cable manufacturers' information about pulse rise time and NRZ data rate is useful for comparing cable types. The Genius bit consists of three AC pulses; the equivalent NRZ bit rate is about three times as great.

For assistance in selecting a cable type, please consult your local GE Fanuc application engineer.

Bus Length

The maximum bus length for shielded, twisted-pair cable is 7500 feet. Some cable types are restricted to shorter bus lengths. If the application requires greater bus length, fiber optics cable and modems can be used. For more information, see the *Genius I/O System and Communications Manual*.

Baud Rate Selection

The bus length determines which baud rate may be selected. A Genius bus can operate at one of four baud rates: 153.6 Kbaud standard, 153.6 Kbaud extended, 76.8 Kbaud, or 38.4 Kbaud. The baud rate selected should be indicated on all devices, especially if different busses in the facility use different baud rates. The baud rate must be configured using a Hand-held Programmer or the system configuration software.

Note that in noisy environments, 153.6 Kbaud extended provides improved noise immunity with little effect on bus scan time. If a system is experiencing excessive blinking of the bus controller's COMM OK light, or if the I/O blocks' I/O Enabled LEDs go off frequently, 153.6 Kbaud extended should be used.

Bus Installation

The Genius bus is connected to the terminal assembly on the front of the GCM module. These terminals have the following assignments:

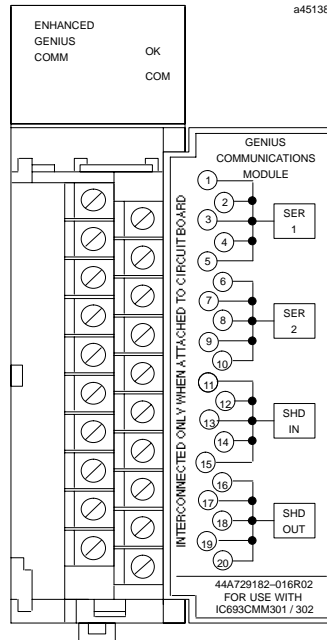

Connection can be made to any of the terminals in a group. The cable is routed to and from the terminals via the bottom of the Terminal Assembly cavity.

Using the cable type selected for the application, connect the Serial 1 terminals of adjacent devices and the Serial 2 terminals of adjacent devices. Connect Shield In to the Shield Out terminal of the previous device. Connect Shield Out to the Shield In terminal of the next device. For the first device on the bus, Shield In is not connected. For the last device on the bus, Shield Out is not connected.

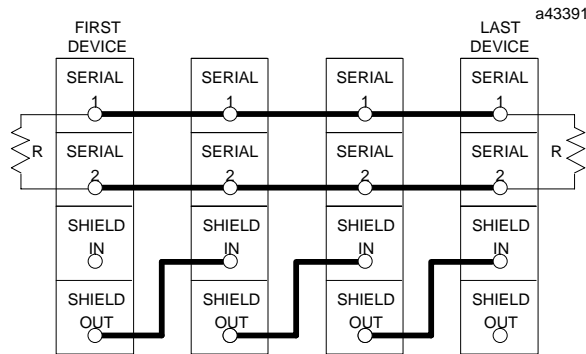

Each terminal will accept up to one AWG #14 wire or two AWG #16 wires using ring or lug-type connectors.

The bus shield wires are not insulated; do not permit them to touch other wires or terminals. The use of spaghetti tubing for this purpose is recommended.

Serial Wire Connections

The Serial 1 and Serial 2 terminals are interconnected *on the circuit board*, not on the terminal strip. Incoming and outgoing signal wire pairs can be connected to either one or two Serial 1 or Serial 2 terminals:

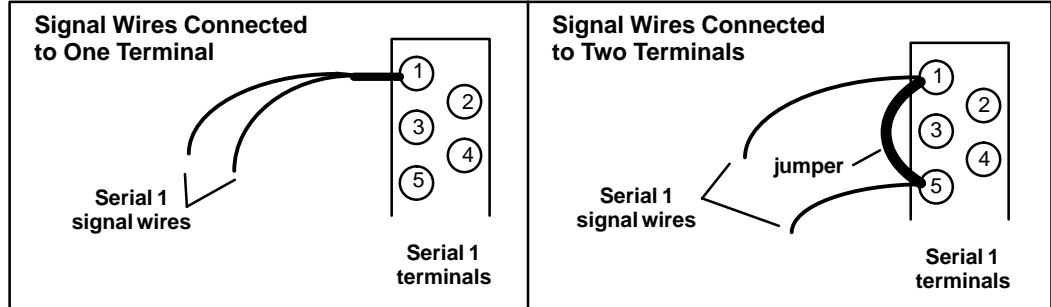

If you are connecting two signal wires to the same terminal, use spade or lug-type connectors, or twist the exposed ends of the wires together before inserting them. This will allow future removal of the Terminal Assembly without disrupting other devices on the bus (see *Module Removal*, in this section).

If you are connecting two signal wires to separate terminals, install a jumper between the two terminals as shown on the right above. Failure to install the jumper will cause the entire bus to be disrupted whenever the faceplate is removed.

Terminating the Bus

The bus must be terminated at both ends by the cable's characteristic impedance. The list of cable types includes termination requirements. If the GCM is at the end of the bus, install a resistor of the appropriate impedance across its Serial 1 and Serial 2 terminals as shown below.

If you need to install the terminating resistor across different terminals than those used for the signal wires, attach jumper wires between the signal wire terminals and the resistor terminals to prevent the bus from becoming unterminated if the Terminal Assembly is removed. Failure to do so will cause the entire bus to be disrupted whenever the faceplate is removed.

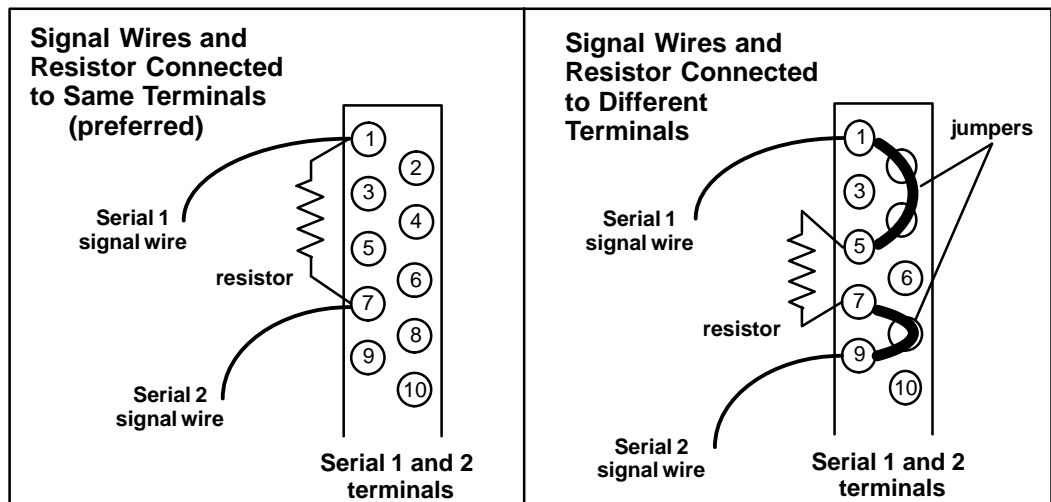

Wiring Guidelines

Four types of wiring may be encountered in a typical factory installation:

1. Power wiring – the plant power distribution, and high power loads such as high horsepower motors.
2. Control wiring – usually either low voltage DC or 120 VAC of limited energy rating. Examples are wiring to start/stop switches, contactor coils, and machine limit switches. This is generally the interface level of the Genius discrete I/O.
3. Analog wiring – transducer outputs and analog control voltages.
4. Communications and signal wiring – the communications network that ties everything together, including computer LANs, MAP, and the Genius communications bus.

These four types of wiring should be separated as much as possible to reduce the hazards from insulation failure, miswiring, and interaction (noise) between signals. A typical PLC system may require some mixing of the latter three types of wiring, particularly in cramped areas inside motor control centers and on control panels. In general, it is acceptable to mix the Genius bus cable with the I/O wiring, as well as associated control level wiring. All noise pickup is cumulative, depending on both the spacing between wires and the distance span they run together. I/O wires and Genius bus cable can be placed randomly in a wiring trough for lengths of up to 50 feet. If wiring is cord-tied (harnessed), do not include the bus cable in the harness, since binding wires tightly together can damage some cable types.

Wiring external to equipment and in cable trays should be separated following NEC practices.

Lightning Transient Suppression

Running the bus cable outdoors or between buildings may subject it to lightning transients beyond the 1,500 volt transient rating of the system. Installing cable underground reduces the probability of a direct lightning strike. However, buried cables can pick up hundreds of amperes of current when lightning contacts the ground nearby.

Therefore, it is important to protect the installation by including surge protectors on underground data lines. The cable shields should be grounded directly. Surge suppressors and spark gaps should be used to limit the voltage that might appear on the signal lines. It is recommended to install two (only) silicon surge suppressors or spark gaps to control transients of 1 to 25 Kilovolts from 100 to 1000 amps or more. These devices should be installed close to the entrance of the bus to the outdoors.

Silicon Surge Suppressors are available many sources, including Clare/General Instruments and Motorola, For information about this product, in the US contact Lucas Industries Incorporated, 5500 New King Street, Troy, Michigan 48098. Spark gaps are available from Clare. Refer to the vendor's literature for installation details.

In extreme situations such as totally-isolated power systems, additional protection against lightning damage should be provided by adding surge suppressors for groups of I/O blocks. Such suppressors should be installed from incoming power leads to ground (enclosure baseplate/block case where leads enter the enclosure).

A device specifically designed to protect the Genius bus is available from CONTROL TECHNOLOGY, 835 Hwy 90, Hancock Square Suite 10 (P. O. Box 2908), Bay Saint Louis, MS 39520. (tel 601 466- 4550, fax 601 466- 4553). Contact them for application information. The device must be used in combination with power line suppression to fully protect the system.

Installing a Hand-held Monitor Connector

The GCM does not have a built-in connector for a Genius Hand-held Monitor. However, a Hand-held Monitor connector can be added directly to the serial bus at any location.

The unit shown below (catalog number 44A736310-001-R001) provides a Hand-held Monitor connector and serial bus terminals in a single convenient package.

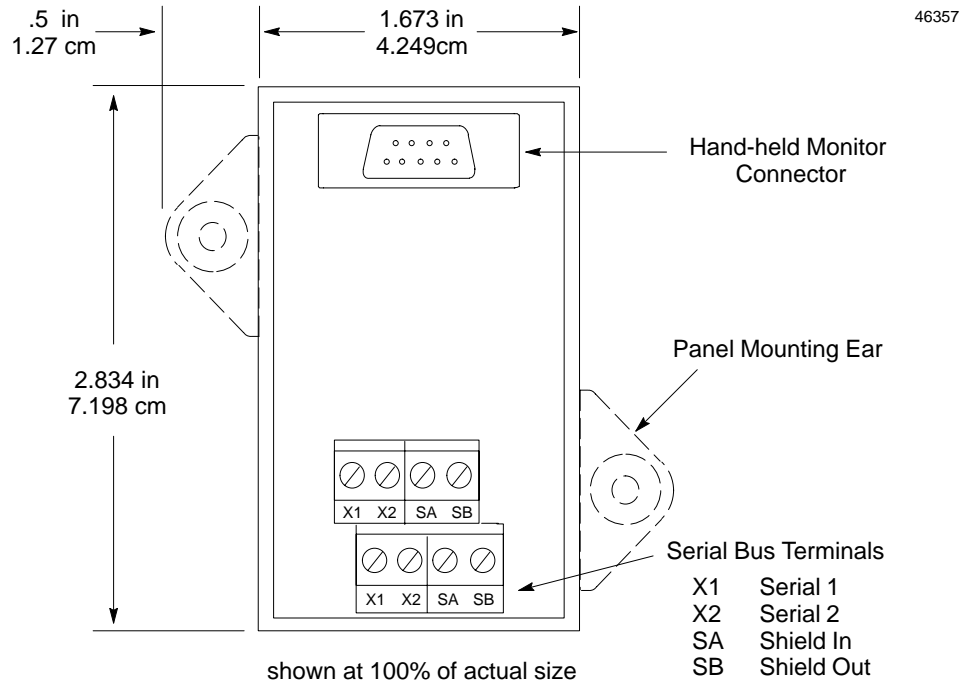

Mounting the HHM Connector

This unit can be easily mounted on a rail such as a standard 35mm or 15mm DIN rail. The panel-mounting ears are not used if the unit is installed on a DIN rail.

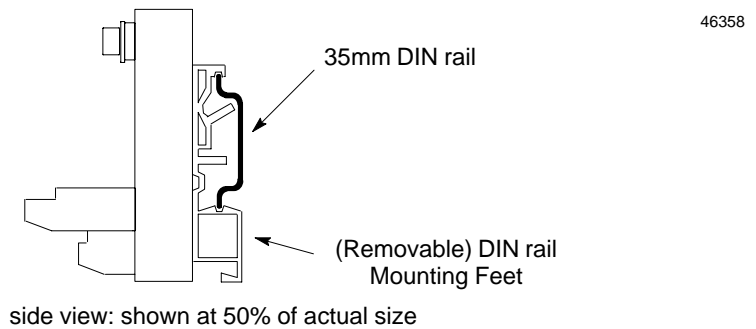

Alternatively, it can be installed directly on a panel using screws through its mounting ears. The DIN rail feet on the back of the unit are removed when the unit is panel-mounted.

Making the Bus Connections

The Hand-held Monitor connector has two sets of terminals; one for incoming cable and the other for outgoing cable.

Connect the Serial 1, Serial 2, and Shield In terminal of either connector to the previous device. Connect the Serial 1, Serial 2, and Shield In terminal of the other connector to the next device.

The following illustration shows connections for incoming and outgoing serial bus cable. As with other devices, the HHM connector can be at either end of its bus. If it is, there will only be one bus cable attached.

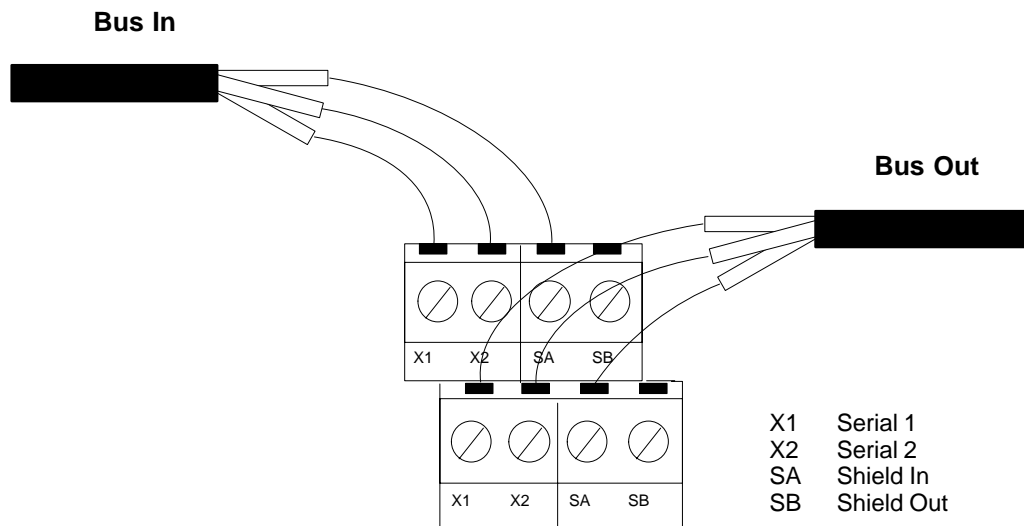

As with other devices, if the Hand-held Monitor Connector is at either end of its bus, install an appropriate terminating resistor across the Serial 1 and Serial 2 terminals.

Installing the Hand-held Monitor D-Shell Connector on the Bus

You have the option of installing the D-shell connector that is supplied with the Hand-held Monitor. You will need a mounting plate (IC660MPH509) for this type of installation.

1. Using the mounting plate as a template, cut an opening in the panel for the mating connector. Also drill two holes for the mounting hardware.
2. Attach the mounting plate and mating connector to the panel using the mounting hardware supplied.
3. Secure the two ends* of the serial bus cable to the back of the panel using strain relief brackets.
4. Strip the ends of the wires. Twist the two Serial 1 wires together and attach them to pin 5 of the connector. Twist the Serial 2 wires together and attach them to pin 9. Similarly, attach the Shield wire(s)* to pin 4.

The following illustration shows connections for incoming and outgoing serial bus cable. As with other devices, the HHM connector may be at either end of its bus. If it is, there will only be one bus cable attached.

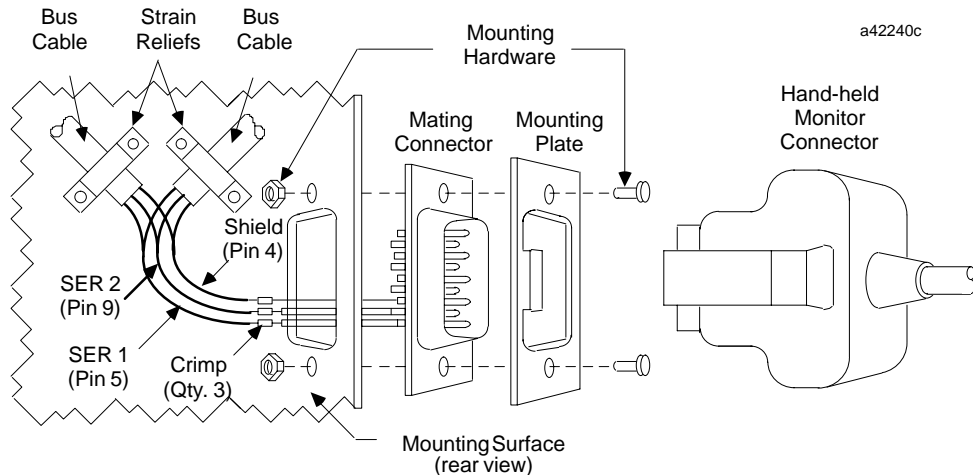

When making bus connections, the maximum exposed length of bare wires should be two inches. For added protection, each shield drain wire should be insulated with spaghetti tubing to prevent the Shield In and Shield Out wires from touching each other.

If the Hand-held Monitor connector is at either end of its bus, it is necessary to install an appropriate terminating resistor across the Serial 1 and Serial 2 wires.

Chapter 3

Operation and Timing

This chapter explains:

- Global (%G) Memory in the Series 90-30 PLC
- How the Devices on the Bus Handle GCM Global Data
- Timing Considerations
 - Estimating Bus Scan Time
 - Relationship Between the Bus Scan and the CPU Sweep
 - Estimating Data Response Time

Global (%G) Memory in the Series 90-30 PLC

A portion of the Series 90-30 PLC’s memory is reserved for Global Data. This bit-oriented memory uses the prefix %G. The amount of %G memory available depends on the CPU type. For example, the model 311 CPU has 256 bits (32 bytes) of Global Data memory and the model 331 CPU has 1280 bits (160 bytes).

%G memory is divided into 4-byte increments, each of which corresponds to a Device Number from 16 to 23 on the bus. The %G locations and default data lengths are listed below.

Device Number	Associated Memory Address
16	%G001 to %G032
17	%G033 to %G064
18	%G065 to %G096
19	%G097 to %G128
20	%G129 to %G160
21	%G161 to %G192
22	%G193 to %G224
23	%G225 to %G256

The GCM uses this %G memory for both sending and receiving Global Data.

If a GCM is set up to send Global Data, it will “broadcast” some or all of the data in %G memory to all other devices on the communications bus.

Unless this uses up the PLC’s entire %G memory space, the module can also receive incoming Global Data from up to seven other devices on the bus. This data will be placed into the appropriate %G memory locations.

Global Data Lengths

The amount of Global Data that can be sent by each GCM depends on how many GCMs will be sending Global Data. For example, a bus might have four GCMs, with one sending 32 bytes of Global Data to the other three.

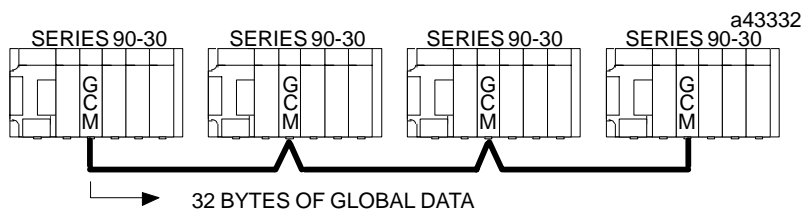

Or, each GCM might send 8 bytes of Global Data to the others.

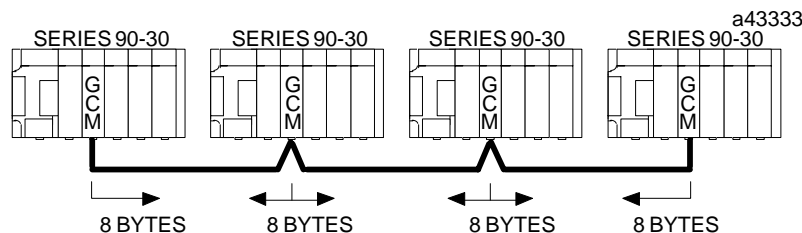

The amounts of Global Data a Genius Communications Module will send and receive are selected during configuration.

Global Data Lengths and Device Numbers

If any Genius Communications Module will send more than 32 bits of Global Data, one or more of the succeeding Device Numbers cannot be used by any device which will send Global Data. However, such a Device Number can be used by a Genius Communications Module that will receive data only, or by another type of device on the bus.

In the following example system, there are three Series 90-30 PLCs with Genius Communications Modules. The PLC on the left broadcasts 32 bits of Global Data to the other two. Its Genius Communications Module is assigned Device Number 16. The second PLC broadcasts 64 bits to the other two. Its Device Number assignment is 17. Because the third PLC does not send any Global Data, although it receives the Global Data from the others, its Genius Communications Module could be assigned Device Number 18.

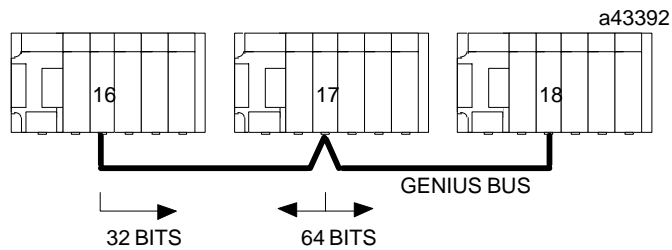

How the Devices on the Bus Handle GCM Global Data

One Genius communications bus can serve up to 32 devices, including interface modules like the GCM, Genius I/O blocks, and Genius Hand-held Monitors. Any combination of these devices may be present on a bus which will be used for Global Data.

GCM Receives Global Data

Any bus interface module that will send Global Data to the GCM must be configured to use a Device Number from 16 to 23. The length of Global Data that will be received from the other device must be compatible with the Series 90-30 %G memory allocation described previously.

GCM Sends Global Data

The GCM can send Global Data to any other hosts on the bus. The following table shows how other hosts handle the data.

Series 90-70 PLC Sends Global Data To	Other CPU Places Global Data in this Memory Location																
Series 90-70 PLC	%I, %Q, %G, %R, %AI, %AQ memory if manual configuration used, or %G if automatic configuration used. Memory type and beginning address selected during configuration of the <u>receiving</u> Series 90-70 bus controller.																
Series 90-30 PLC with GCM Module	%G memory location corresponding to Device Number (16-23) of Series 90-30 bus controller that sent the data. Adjusts for message length.																
Series 90-30 PLC with Bus Controller or GCM+ Module	Configured memory location.																
Series Six PLC or Series Five PLC	Register memory location that corresponds to the Device Number of the Series 90-30 Genius Communications Module: <table style="margin-left: auto; margin-right: auto;"> <tr><td>16</td><td>%R001 to %R002</td></tr> <tr><td>17</td><td>%R003 to %R004</td></tr> <tr><td>18</td><td>%R005 to %R006</td></tr> <tr><td>19</td><td>%R007 to %R008</td></tr> <tr><td>20</td><td>%R009 to %R010</td></tr> <tr><td>21</td><td>%R011 to %R012</td></tr> <tr><td>22</td><td>%R013 to %R014</td></tr> <tr><td>23</td><td>%R015 to %R016</td></tr> </table> Adjusts for message length.	16	%R001 to %R002	17	%R003 to %R004	18	%R005 to %R006	19	%R007 to %R008	20	%R009 to %R010	21	%R011 to %R012	22	%R013 to %R014	23	%R015 to %R016
16	%R001 to %R002																
17	%R003 to %R004																
18	%R005 to %R006																
19	%R007 to %R008																
20	%R009 to %R010																
21	%R011 to %R012																
22	%R013 to %R014																
23	%R015 to %R016																
Computer	PCIM or QBIM Input Table Segment corresponding to Device Number of sending device.																

Additional Considerations

Series 90-30 PLC GCM+ Module or Bus Controller A GCM+ or Bus Controller module in another Series 90-30 PLC places the data in the memory location specified when that module is configured. If a GCM+ module does not need all of the data, a message offset and length can be specified. However, a Bus Controller must receive all of the data.

Series 90-70 PLC To transfer Global Data with a GCM, the configuration of the Series 90-70 PLC must be set up to specify the Genius Communications Module (IC693CMM301) as a device on the bus.

Series Six PLC To transfer Global Data with a Series Six PLC, the Series Six Bus Controller must be catalog number IC660CBB902F/903F (firmware version 1.5), or later. For the Series Six PLC, Global Data must be initialized by sending a Write Configuration command to that Bus Controller. The command must specify a location in register memory where the Global Data to be sent will begin.

The Series Six PLC automatically receives Global Data sent by any GCM which sends it. This data will be placed in register memory locations that correspond to the sending device's Device Number.

Device Number	Associated Memory Address
16	%R001 to %R002
17	%R003 to %R004
18	%R005 to %R006
19	%R007 to %R008
20	%R009 to %R010
21	%R011 to %R012
22	%R013 to %R014
23	%R015 to %R016

It is important to be sure that registers corresponding to Device Numbers that will send Global Data are not used for anything else in the program, even if the Series Six PLC will not make use of the Global Data it receives. If a device using one of the above Device Numbers sends Global Data, it will always be received if the Series Six PLC application program opens a window to the Bus Controller (using a DPREQ or WINDOW instruction or the Computer Mailbox).

If the Series Six PLC is set up for Expanded I/O addressing, registers R001 through R0016 are used for Auxiliary Output Table references AO0001 to AO0256. Auxiliary outputs that correspond to Device Numbers that broadcast Global Data *should not be used*.

Series Five PLC A Series Five PLC can send Global Data to the GCM. The Series Five Bus Controller that will be used must be assigned a Device Number from 16 to 23 (using the Logicmaster Five software, or an Operator Interface Unit).

The Series Five PLC automatically receives Global Data from any GCM that sends it. This data will be placed in register memory locations that correspond to the sending device's Device Number. See the table above.

Computer	A computer on the bus can exchange Global Data with a GCM. The computer's Bus Controller (a PCIM or QBIM) places Global Data sent by the GCM into a memory location that corresponds to the Device Number of the GCM module. The computer's application program is responsible for transferring Global Data between its CPU and the PCIM or QBIM.
I/O Blocks	<p>I/O blocks (controlled by another host) can be present on the bus. Their operation will not interfere with Global Data transfer.</p> <p>If a block were assigned a Device Number from 16–23 and the Genius Communications Module were configured to receive from that Device Number an amount of data equal to the number of inputs from the block, the Series 90-30 PLC could monitor the input data. However, it could not send any outputs back to the block.</p> <p>It is possible to use inputs-only blocks on a bus with a Series 90-30 PLC monitoring input data, and no other host (or the Series 90-30 PLC) sending outputs. However, a block's I/O Enabled LED, which reflects the presence of communications from the host, would never light because the block would not receive such communications from the Series 90-30 PLC.</p>
Genius Hand-held Monitor	A Genius Hand-held Monitor can be used to display bus status information and to display the Global Data address of the Series 90-30 PLC. HHM version IC660HHM501C or later is required.

Timing Considerations

Communications on the bus occur by a method called “token passing”. In this method, the devices on the bus pass an implicit token, which rotates among the devices in sequence from device 0 to device 31. Unused Device Numbers are passed with very slight delays. This sequence is called a bus scan. After device 31 has had its turn, the scan restarts at device 0.

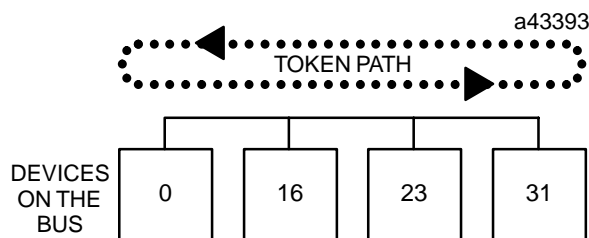

Each device on the bus can listen to messages at all times (not just when it has the token). A Genius Communications Module listens to all broadcast messages. These are messages that are sent to all devices on the bus. Global Data is a type of broadcast message.

While each device holds the token, it can send messages. To end its turn, the transmitting device sends one specific broadcast message which acts as a sign-off message, and the token passes to the next device.

Bus Scan Time depends on the baud rate, the devices on the bus, and the use of programmed communications and redundancy. However, although the presence of other devices and communications determines the speed with which the communications token advances from device to device, it does not affect the actual transmission time of an individual message.

Estimating Bus Scan Time

The minimum amount of time required for the token to make a complete bus scan rotation is 3mS. This minimum time limit is imposed by the Genius Communications Module and other types of bus interface modules. The maximum possible bus scan time is 400mS, but this will never be reached under normal circumstances

If the bus includes other types of controllers or Genius I/O blocks, bus scan time can be estimated as described in the *Genius I/O System User's Manual*.

If the bus includes only Series 90–30 PLCs with GCM modules, bus scan time can be estimated by adding up the time required to service all Devices Numbers on the bus (including unused Device Numbers). Times per Device Number are shown in this table:

Device Type	Contribution time in mS at each baud rate			
	153.6 Kb std	153.6 Kb ext	76.8 Kb	38.4 Kb
GCM	1.09	1.16	2.33	4.66
Unused Device Number	0.026	0.052	0.104	0.208

The data rate has a direct bearing on bus scan time. The scan time increase from 153.6 Kbaud standard to 153.6 Kbaud extended is slight. However, the scan time is approximately twice as long at 76.8 Kbaud, and four times as long at 38.4 Kbaud.

Relationship Between the Bus Scan and the CPU Sweep

The bus scan is completely independent of the CPU Sweep. The CPU sweep is the Series 90–30 PLC’s regular cycle of program execution, I/O update and other tasks. The Genius Communications Module acts as the interface between these two asynchronous activities—the bus scan and the CPU sweep. It stores Global Data it has received from other devices on the bus. In the following example, two devices (18 and 22) send Global Data on the bus. Each module broadcasts its Global Data while it has the bus token. The Global Data is received by a Genius Communications Module in a Series 90–30 PLC.

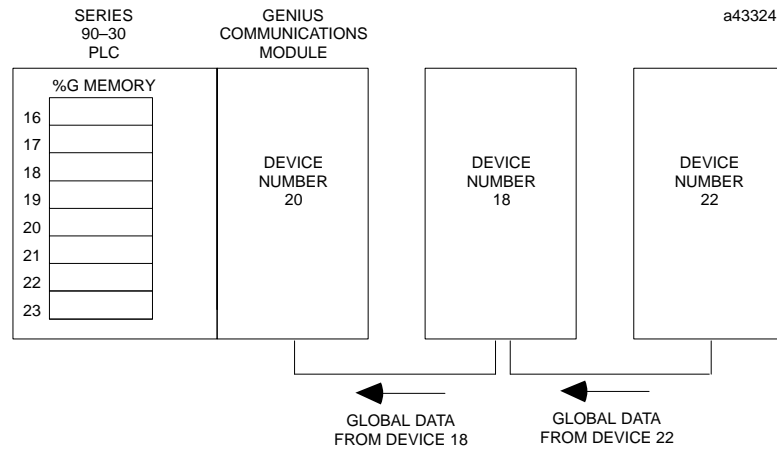

The Genius Communications Module (Device Number 20, above) stores the Global Data it has received. When the Series 90–30 CPU executes the input update portion of its sweep, it reads this Global Data from the module. It copies the data into the %G memory locations associated with Device Numbers 18 and 22.

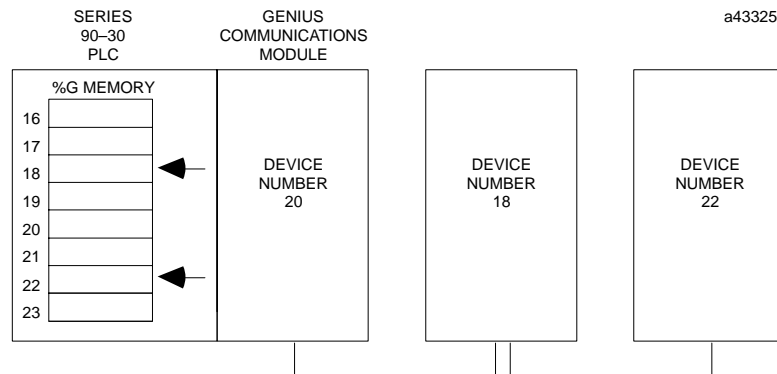

After the CPU scans inputs, it executes the application program. This program can use the new Global Data it has received from other modules on the bus. If it will send Global Data, it must include logic capable of placing data into the %G memory location assigned to its Genius Communications Module. The content of this %G memory location will be sent to the Genius Communication Module when the PLC updates outputs, after the application program executes. This activity is asynchronous with the bus scan.

Continuing the same example, after executing its program the CPU sends new Global Data to its Genius Communications Module from the %G memory location associated with Device Number 20.

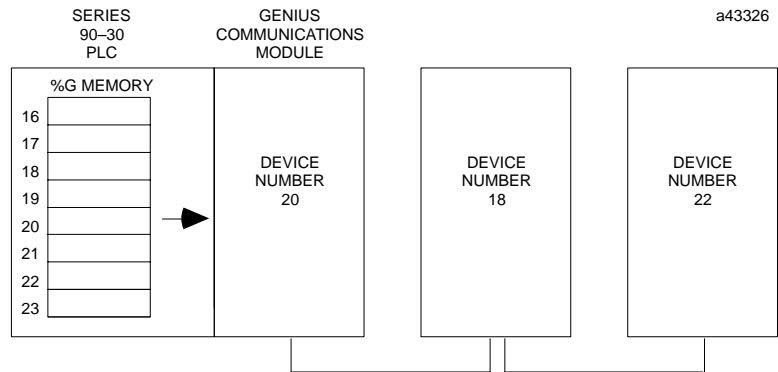

The Genius Communication Module stores this data until it receives the bus token. At that time, it will broadcast the data to all the other devices on the bus. In the example system, both Device 18 and Device 22 will receive the Global Data sent by Device 20:

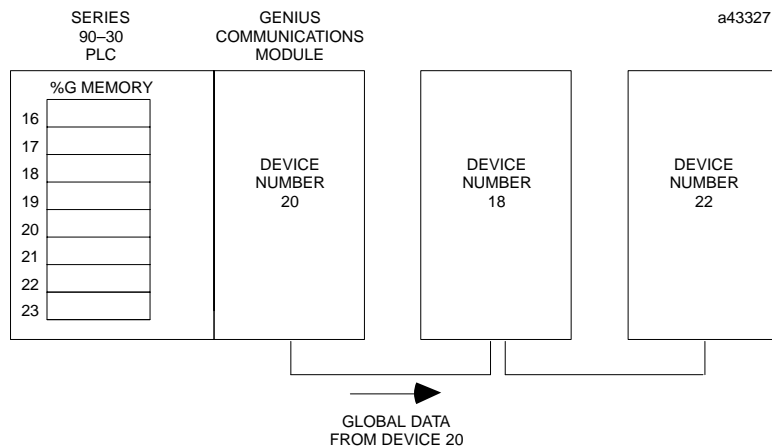

If program execution time is slower than bus scan time, it is possible that some incoming Global Data might change before it is picked up by the CPU. It is important to be sure that the data will not be sent so briefly that it will be missed.

If program execution time is faster than bus scan time, the CPU may process the same data repeatedly.

To the time required to service all devices, add the time required for all the Global Data that will be sent by the Genius Communications Modules on the bus. *Each Global Data message will be sent every bus scan.* Therefore, the total size in bytes of each message contributes to the scan time. Each Global Data message also includes a 1-byte Start of Block (SOB) and a 1-byte End of Block (EOB). For example, if two devices on the bus EACH sent a 4-byte Global Data message, the total would be:

$$\begin{array}{rcl}
4 \text{ byte message} & + & 2 \text{ bytes (SOB and EOB)} & = & 6 \text{ bytes} \\
4 \text{ byte message} & + & 2 \text{ bytes (SOB and EOB)} & = & \underline{6} \text{ bytes} \\
& & \text{Global Data addition} & = & 12 \text{ bytes}
\end{array}$$

The time required to transmit the data depends on the baud rate. After adding together the message bytes for Global Data, multiply the total by one of the following transmission rates:

- 0.0715mS/byte for 153.6 Kbaud (either standard or extended)
- 0.143mS/byte for 76.8 Kbaud
- 0.286mS/byte for 38.4 Kbaud

Example:

In this example, there are 8 Series 90-30 Genius Communications Modules on the bus (and no other devices). Each module is sending 4 bytes of Global Data. The baud rate on the bus is 153.6 Kbaud standard. Scan time on this bus would be:

8 Genius Communications modules (8 x 1.09)	8.72mS
24 unused Device Numbers (24 x 0.026)	0.62mS
8 Global Data messages, 4 bytes each ((4 + 2) x 0.0715)	<u>3.43mS</u>
Total bus scan time	= 12.77mS

Estimating Data Response Time

For applications where it is important to know how long it will take for one module to send Global Data to another and to receive a “reply” based upon that data, you can estimate response time by adding together the maximum time that may be required for each portion of the input to output cycle.

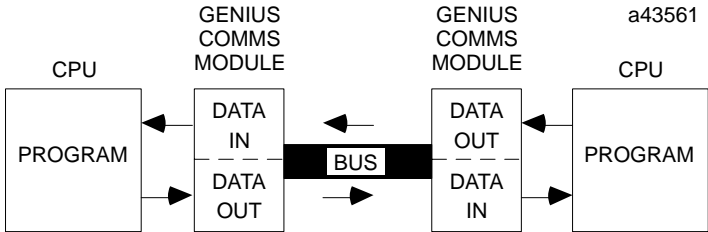

The worst case turnaround response time can be estimated by calculating:

$$2(T_{cpu1}) + 2(T_{bus}) + 2(T_{cpu2})$$

Tbus and Tcpu are explained below.

Bus Scan Time (Tbus)

Tbus is the time that it takes for a complete bus scan (token rotation from 0 to 31). This is calculated by adding all of the bus scan time contributions of devices on the bus and Global Data, as discussed in the preceding pages. The scan time contributions of other types of devices that may be on the bus are listed in the *Genius I/O System User’s Manual*.

Program Execution Time (Tcpu)

A Genius Communications module stores incoming Global Data where it can be accessed by the application program currently executing in the CPU. If the CPU services the module shortly after it receives new input data, the inputs will be read into CPU memory quickly. However, if the module has just been serviced by the CPU, another CPU sweep must elapse before the newly-received Global Data is read.

Sending Data in Reply to Global Data Received

If the application program will send Global Data in response to Global Data it has received, one additional CPU sweep will be required for the application program to process the data.

The same relationship applies to sending Global Data on the bus. If Global data changes as a result of Global Data received, the Genius Communications module will send it on the bus during the next bus scan. If the token has just passed, the Global Data must wait up to the length of the bus scan before the module receives its next turn on the bus.

Chapter 4

Configuration

This chapter describes:

- Configuration planning
- Configurable features of the Genius Communications Module
- Configuration steps using the Series 90-30 Hand-Held Programmer

Configuration Planning

Each device in the system requires configuration. It is important to be sure that the Device Number, baud rate, and data length selected for each Genius Communications Module are compatible with selections made for the other devices on the bus. The form shown below can be used as a sample when planning the configuration of all Genius Communications Modules that will be sharing a bus.

BUS CONFIGURATION			
Bus Description: _____			
Baud Rate (check one):			
153.6 Kbaud st. _____		153.6 Kbaud ex. _____	
78.6 Kbaud _____		38.4 Kbaud _____	
Device Numbers and Global Data Lengths:			
PLC where module is located:	Global Data Length	Device Number of Communications Module	Associated %G Memory Locations
_____	_____	16	%G0001-%G0032
_____	_____	17	%G0033-%G0064
_____	_____	18	%G0065-%G0096
_____	_____	19	%G0097-%G0128
_____	_____	20	%G0129-%G0160
_____	_____	21	%G0161-%G0192
_____	_____	22	%G0193-%G0224
_____	_____	23	%G0225-%G0256

Configurable Features

The GCM can be configured using either the Series 90-30 Hand-Held Programmer or the system configuration software. If the Hand-held Programmer is used, it must be attached to and interfacing with the PLC.

For each Genius Communications Module in the PLC, configuration includes specifying:

1. the module's rack/slot number
2. the baud rate
3. its Device Number (bus address)
4. the length of Global Data SENT by the module
5. the length of Global Data that will be received from other devices

Hand-held Programmer Configuration

For Hand-held Programmer configuration, the PLC must be in Stop mode. If necessary, press the RUN key on the Hand-Held Programmer to change the PLC mode. (When configured with the Hand-Held Programmer, the module starts operating immediately. While the PLC is still in Stop mode, the module transmits zeros. Placing the PLC in Run mode automatically causes the module to be configured and to begin exchanging actual data with the CPU).

If the Hand-Held Programmer is not already in configuration mode, display the Programmer Mode menu by pressing the MODE key. The screen shows:

```
1. PROGRAM   <S
2. DATA
```

The < S in the upper right corner of the screen indicates that the PLC is in Stop mode. Select module configuration by pressing the 4 key, then the ENT (enter) key.

Slot Number

A module's slot number is the location where it is (or will be) installed in the Series 90-30 PLC. Slot 0 is always the Power Supply.

Hand-Held Programmer Display

Press the Right Arrow key from the Mode selection screen to display the configuration screens for each rack and slot. For example:

```
R0:05 GCM BA18 <S
BUS ADDR: 16
```

The top line of the screen indicates the baseplate (R0) and slot (:05) selected. GCM stands for Genius Communications Module. Line 2 of the screen shows module's Device Number (bus address).

Device Number

Each Genius communications bus can serve up to 32 devices, which are identified by Device Numbers from 0 to 31. A module's Device Number is its "bus address". This address represents the module's place in the communications sequence on the bus. Each Genius Communications Module must have a Device Number assigned. As explained in chapter 3, the GCM directly associates each Device Number from 16 through 23 with 32 specific bits in Global Data (%G) memory.

Device Number	Associated Memory Address
16	%G001 to %G032
17	%G033 to %G064
18	%G065 to %G096
19	%G097 to %G128
20	%G129 to %G160
21	%G161 to %G192
22	%G193 to %G224
23	%G225 to %G256

The lengths of Global Data sent and/or received by a device may exceed 32 bits, so it is important to assign Device Numbers that accommodate the actual Global Data lengths.

Hand-Held Programmer Configuration

If the Device Number shown is not correct for this GCM, enter the new number from the keypad. Press the ENT key to change and display the new Device Number. For example:

```
R0:05 GCM <S
BUS ADDR: 17
```

To continue configuring the same module, press the Right Arrow key to display additional selections.

Baud Rate

All devices on a bus must be configured to use the same baud rate: 153.6 Kbaud standard, 153.6 Kbaud extended, 76.8 Kbaud, or 38.4 Kbaud. The module is set to operate at 153.6 Kbaud standard when shipped from the factory.

Baud rate must be selected on the basis of cable type (see the table in chapter 2) and the following considerations.

1. If the cable length is less than 2000 feet, either 153.6 Kbaud standard or 153.6 Kbaud extended can be used. The use of 153.6 Kbaud extended is recommended, especially if the system will include a dual bus with Bus Switching Modules.
2. If cable length is between 2000 and 3500 feet, select 153.6 Kbaud extended.
3. If the cable length is between 3500 and 4500 feet, select 76.8 Kbaud.
4. If the cable length is between 4500 and 7500 feet, you must select 38.4 Kbaud. This data rate only supports a maximum of 16 device on the bus.
5. If there are any older Genius products on the bus (catalog numbers IC660CBDnnn, IC660CBSnnn, IC660CBAAnnn, IC660HHM500, or IC660CBB900/901), the bus must be set up to use 153.6 Kbaud standard.

Hand-Held Programmer Configuration

Pressing the right arrow key once from the Bus Address screen shows the currently-configured baud rate. For example:

```
R0:05 GCM BA18<S  
BAUD:153.6K ST
```

If the baud rate shown is not correct, press the +/- key to change it. When the correct baud rate appears, press the Enter key to change it. Press the Right Arrow key to display the next configurable feature of the module.

Global Data Length

Because each Device Number is associated with a specific starting address in %G memory, each Device Number also has an associated maximum Global Data length, as listed below.

Device Number	Starting Address	Valid Lengths
16	%G001	0..256
17	%G033	0..224
18	%G065	0..192
19	%G097	0..160
20	%G129	0..128
21	%G161	0..96
22	%G193	0..64
23	%G225	0..32

By default, the Genius Communications Module is configured to broadcast 32 bits of Global Data, and not to receive any incoming Global Data from other devices.

If any Genius Communications Module will send more than 32 bits of Global Data, one or more of the succeeding Device Numbers cannot be used by any device which will send Global Data. However, such a Device Number can be used by a Genius Communications Module that will receive data only, or by another type of device on the bus.

Hand-Held Programmer Configuration

The next configuration screen can be used to change the lengths of either broadcast or incoming Global Data. The display shows the Device Number of the module at the indicated slot location. For example:

```
R0:05 GCM*BA17<S
G032:G0033-G0064
```

The asterisk before BA17 in the example above indicates that this is the module currently being configured. The letters BA stand for “bus address”. If the asterisk appears, then line 2 of the display shows the amount of Global Data sent by the module. This Global Data length is shown in bits (in this example, G032). Line 2 also shows the beginning and ending %G memory addresses required for the selected Global Data length (%G0033 – %G0064).

If the correct number of bits is shown, no change is necessary. To change the number of Global Data bits to be sent by the module, enter the new number from the HHP keypad. The number must be a multiple of 32. After entering the number of bits, press the ENT key.

If the module will also receive Global Data from other devices on the bus, press the Right Arrow key to display additional Device Numbers and Global Data lengths.

Select the Lengths of Global Data Received by the Module

The lengths of configured incoming Global Data from Device Numbers 16 to 23 are displayed as the Right Arrow key is pressed on the previous screen. If NO asterisk appears beside the Device Number (bus address) on line 1, then line 2 shows the length of data that *will be received from the module* indicated on line 1.

For example, pressing the Right Arrow key once from the screen shown in the previous example displays the following:

```
R0:05 GCM BA18<S
G032:G00065-G0096
```

There is no asterisk at the left of the Device Number. That shows the device is not the one currently being configured; the length selected on this screen would be the amount of Global Data being received by Device Number 17 from Device Number 18.

To change a Global Data length, type in the number of bits from the HHP keypad. If there is no device using the Device Number, or if a device at the number will not send any Global Data, enter a 0. After making an entry, press the ENT key.

Continue entering incoming Global Data lengths from other Device Numbers, as appropriate. If any device is assigned a Global Data length that is more than 32 bits, one or more of the following Device Numbers will not appear for selection. For example, if Device Number 20 were assigned 64 bits of Global Data length, no configuration screen for Device Number 21 would appear, and Device Number 21 could not be used.

Characteristics of the Genius Bus

This appendix describes the characteristics of the bus cable that links Genius devices.

- Electrical Interface
- Serial Bus Waveforms
- Effect of Long Cables, Repeaters, or Unspecified Cable Types on Bus Length
- Serial Data Format
- Bus Access
- Bus Errors Caused by Noise

This information supercedes the equivalent text portion of chapter 2 of the *The Genius I/O System and Communications Manual* (GFK-90486), "The Communications Bus".

A Genius serial bus consists of two or more Genius devices, and (usually) the bus cable that connects them. A single block or bus controller with a Hand-held Monitor directly attached, properly terminated with a 75Ω resistor, are considered the smallest possible Genius communications bus.

Electrical Interface

The Genius serial bus uses computer grade twisted pair data cable. The half duplex token sequence used requires only a single pair since at any time only one station is transmitting and all others are receiving. All stations must receive in order to track the present token value and take their appropriate turn on the bus, regardless whether the data is to be used locally. The transmit sequence is the same as the serial bus address (SBA) set into each location during configuration. A simplified interface circuit is shown below:

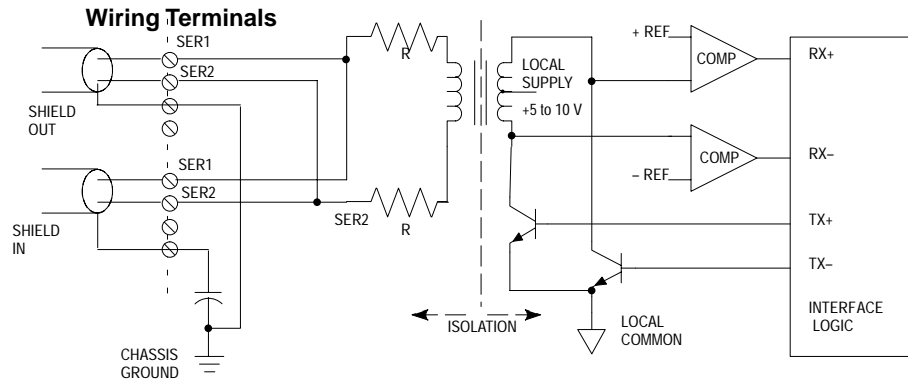

Signal coupling to the bus is via a high frequency, high isolation pulse transformer. This permits the bus and the local logic to be at different voltage levels. The pulse waveforms are bipolar (see next section below) to reduce DC baseline offsets in the waveform.

The daisy-chained bus is shown on the left in the above illustration. The SER 1 and SER 2 lines are merely tapped at the intermediate locations along the bus. These connections must be consistent since the signal is polarized. The shield of the cable is broken into segments at each location. Each shield segment is DC grounded at one end (SHIELD OUT), and terminated with a small capacitor at the other (SHIELD IN). The segmenting breaks up long ground loop paths. The capacitor termination reduces common mode noise from high frequency pickup, while preventing large ground loop currents in the shield at low frequencies.

The alternately switching transistors produce a negative pulse followed by a positive pulse across **SERIAL 1** relative to **SERIAL 2**. The bit waveform is a series of these pulses, as will be shown later. The transformer provides isolation (2500 volts test) between the bus and the local logic, permitting these to be at different voltages. The internal resistors in each line provide current limit and some termination function during transmission.

The balanced (differential) signals on the twisted pair provide high noise immunity due to the magnetic (H field) cancellation effect of the twisting, as well as electric (E field) reduction by the shielding. Most remaining noise pickup is common mode: the transformer provides a high common mode noise rejection by looking only at the differential signal across the SER 1-2 lines. The two input comparators detect the positive polarity input pulses separately from the negative; these are sent to a custom interface logic chip which digitally filters these for timing and sequence, then reconstructs the NRZ digital data. Voltages between the two thresholds are ignored. This filtering, and the high input threshold if the comparators, are highly effective in rejecting both random impulse noise and low level line reflections. Finally a CRC-6 checksum check is performed before the data is sent to the local processor (not shown).

Genius Transceiver Electrical Specification

Property	Min	Max
Normal peak voltage Vp into 78 ohm terminated cable (1)	3.5 volts	5.5 volts
Normal peak voltage Vp into 150 ohm terminated cable (1)	6.0 volts	9.5 volts
Rated bus impedance (2)	78 ohms	150 ohms
Maximum output voltage (SER 1 and 2 open) (3) Peak RMS		35 volts 15 volts
Maximum output current (SER 1 and 2 shorted together) Peak RMS		180 milliamp 50 milliamp
Transmitter source resistance	80 ohms	140 ohms
Transmitter source inductance (transformer leakage inductance)		10 microhenries
Receiver input threshold; +Vr, -Vr (4)	0.7 volt	1.1 volt
Receive mode input impedance	10 K ohm	
Receive mode load inductance (transformer shunt inductance)	6 millihenries	12 millihenries
Receiver common mode rejection (DC to 1 MHz)	60 dB	
Shield capacitor termination	0.1 microfarad	
Isolation, serial bus to circuit, continuous	240 volts AC	

Notes:

- (1) Vp may vary among various module types.
- (2) Rated load is half cable impedance when termination is included.
- (3) Peak open circuit voltage contains underdamped ringing due to lack of termination.
- (4) Input voltages between +Vr and -Vr thresholds are ignored.

Serial Bus Waveforms

The actual waveforms seen on the cable depend on the cable impedance and the distance from the station presently transmitting. A data "0" is a series of three AC pulses, while a "1" is no pulse.

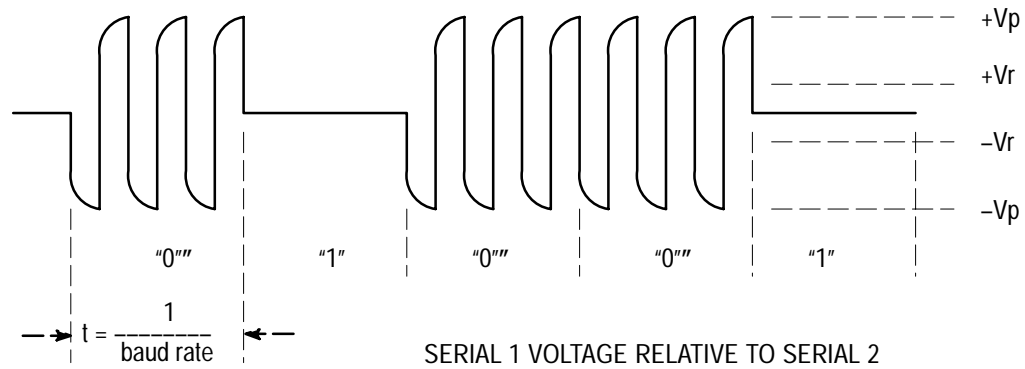

Use caution when connecting instrumentation to the bus. A differential probe or a summation of two probes relative to ground is required. Inadvertent grounding of one side of the bus can cause loss of data or data errors.

The pulse frequency is three times the baud frequency, for example 460.8 KHz at 153.6 Kb.

The peak transmitted voltage V_p and the receiver thresholds V_r are per the electrical specification above. The peak voltages measured will decline with distance along the cable from the transmitting station, so different stations will have varying amplitudes. The wave shape will also become more rounded with distance.

The minimum amplitude pulses seen during a "0" should exceed the receiver threshold V_r of 900 millivolts by 50% (about 1.4 volts) for best reliability. An occasional pulse at or below the threshold may still not cause the bit to be missed, due to a voting algorithm in the logic, however.

Likewise, no pulses greater than V_r should exist during logic "1" intervals. Occasional extra pulses during this interval are also rejected by the logic.

Line reflections will show up as notch distortion during the pulse or low level pulses during "1" intervals, and their appearance is synchronized to the baud frequency. These cause no problem if they do not cause violation of the amplitude criteria of the previous paragraphs.

The Serial 1 and Serial 2 lines should always have a termination resistor equal to the characteristic impedance of the cable connected at each extreme end. When testing a Genius block or other device using a Hand Held Monitor, when no serial bus is present, a terminating resistor will improve integrity. 75 Ohms is recommended.

Effect of Long Cables, Repeaters, or Unspecified Cable Types on Maximum Length Bus

Three effects limit the maximum length bus available at any baud rate:

1. Voltage attenuation
2. Waveform distortion (frequency dispersion)
3. Propagation delays

Attenuation

The transmitter output levels and receiver thresholds determine the maximum attenuation that can be tolerated. For Genius products, this is the principal determinant when using recommended cable types.

Distortion

Waveform distortion is due to the limited bandwidth of wire media, which causes the various frequency components of a pulse waveform to travel at different speeds and thus arrive separately in time (called dispersion). As a result, the received pulse appears rounded and distorted. The signal at the extreme end from the transmitter may look rounded and skewed as shown below. Distortion is most apparent near the beginning and end of a pulse train where it may appear as a change in phase or a frequency shift. Critical timing for a logic 0 transmission is shown below in a more detailed version of the waveform:

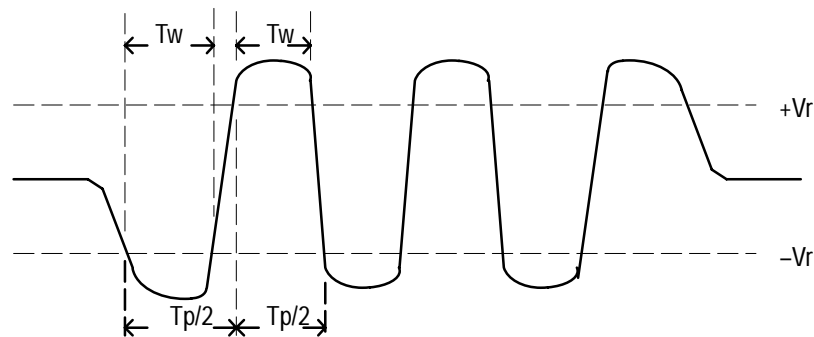

Note the first and last half-cycle look wider. The most critical to operation is the first full cycle of the first start bit of the transmission. Detection of this pulse establishes the time synchronization of the receiver to the incoming waveform. Missing this first pulse does not cause the data to be missed, but may compromise the noise immunity with respect to extra or missing pulses. The frequency of the AC pulse is 3X the baud rate as noted earlier. This means the normal period $T_p(\text{normal})$ is:

- 2.17 microseconds at 153.6 Kb
- 4.34 microseconds at 76.8 Kb
- 8.68 microseconds at 38.4 Kb.

The half cycle pulse width, when measured between the positive and negative receiver thresholds, denoted as $T_p/2$ in the figure, will vary along the waveform due to dispersion, and resembles a frequency shift. The digital input filter essentially is a band pass filter which looks at the half cycle timing $T_p/2$, and the duration above the thresholds, T_w . The limits are:

- $T_p/2 = 0.6 T_p(\text{normal})$ maximum
- $T_w = 0.188 T_p(\text{normal})$ minimum

These measurements can be taken when evaluating the maximum length of an unspecified cable. Dispersion is much less of a problem with fiber optic links since the media is much wider bandwidth, and therefore has less distortion.

Propagation Delay

The propagation delay is caused by travel time of the signal down the cable. Typical signal velocity in data grade cables is around 65– 78% of the speed of light. This requires about 3 microseconds to travel a 2000 foot long bus. This is about half a bit time at 153,6 Kb. This skew could affect the bus access sequence since only one bit of quiet bus (skip) time is usually allocated between transmission of adjacent addresses. (Refer to Bus Access Time section below.) The signal must reach all devices on the bus within the period of one bit. Propagation delay causes the ultimate limitation in bus length, even with ideal media. Propagation speed through fiber optic is not significantly different than wire, and delays through the interfaces must be accounted for.

Serial Data Format

The Genius protocol is designed to produce maximum throughput of data by using a minimum overhead of control and synchronizing characters.

Each character is 11 bits long, comprising a start bit (always 0), next a control bit, followed by 8 bits of data, sent LSB first. The last bit is a stop bit, always 1. Successive characters are sent with no time space between them. The control bit is used to signal the type of character being sent. A 1 indicates a control character, and 0 a data character.

A minimum transmission is comprised of a start character, one or more data characters, and a stop character. The Start character data contains the address and whether the transmission is directed to a specific address or a broadcast to all. The End character contains the CRC– 6 checksum. More complex transmissions may have additional start and end of block characters to break up the message into “blocks” of data (not to be confused with Genius I/O “Blocks”). For example, a Bus Controller can send device specific messages (blocks of data) to all devices on the bus during one transmission cycle.

Bus Access

All devices must receive the current SBA and the stop character even though the data is irrelevant locally. After the stop control character is received, each device on the bus starts a timer. The time delay is equal to a “skip time”, times the difference between the device Serial Bus Address (SBA) and the last SBA received. The device will transmit after the time delay if no other start bits are detected first. Thus each device takes turn in order of SBA. Unused SBAs result in longer times between messages. All devices must detect messages within this skip time delay. A bus “collision” (two sources transmitting simultaneously) results if this sequence is missed. The skip time value is equal to one bit period, except on the 153.6e rate, where it is two bit periods long. The longer interval is useful to accommodate the longer propagation delays due to longer bus cables, or when delays are introduced by fiber optic or other repeaters, The worse case is when adjacent SBAs are physically located at opposite ends of a long bus. For example, assume SBA 4 and 6 are at one end of a 2000 foot bus and SBA5 at the other, operating at 153.6s Kb. When SBA 4 end character is detected, SBA6 immediately starts timing 2 skip times (13 uSec) to start of it’s transmission. SBA5 receives the end character 3 uSec later, and starts timing 1 skip time (6.5 uSec). Thus SBA 5 will start transmitting 9.5 uSec after SBA 4 quit. This allows 3.5 uSec for the signal to get back to SBA6 to cancel it’s transmission turn. The 3 uSec transmission delay leaves only 0.5 uSec to do this and avoid a collision between SBA5 and 6.

Bus collisions result in missing data or detected CRC errors. Problems resulting from bus collisions can be fixed by not using (skipping) a SBA, resequencing SBAs in order along the bus, going from 153.6s baud to the 153.6e, or a lower baud rate.

Bus Errors Caused by Noise

Most capacitively- and magnetically-coupled noise shows up as common mode voltage on the bus. The bus provides a 60 dB common mode rejection ratio. A noise spike above 1000 volts would be required to corrupt the data. The bus receivers filter out corrupted data and perform a 6-bit cyclic redundancy check to reject bad data. Corrupted signals due to noise show up as missed data rather than incorrect data. The bus continues operating to the maximum extent possible when bus errors are detected; random bus errors do not shut down communications. Bad data is rejected by the receiving device and excessive errors are reported to the controller. Bus errors are indicated by flickering of I/O block and bus controller LEDs. If excessive bus errors occur, the problem should be found and corrected.

Appendix B

Comparison of the GCM and GCM+

This appendix summarizes the basic differences between the Genius Communications Module (GCM) and the Enhanced Genius Communications Module (GCM+). Both types of module can be used on the same bus, but they cannot be installed in the same PLC. The two types of module can exchange global data with each other.

	GCM	GCM+
ModuleNumber	IC693CMM301	IC693CMM302
Quantity per 90-30 PLC	1	3
GlobalDataLengths: transmitted received	up to 256 bits total global data, transmitted and received	up to 128 bytes up to 128 bytes each from up to 31 other devices
Number of Other Global Data Devices	7	31
Bus Addresses (SBAs) for Global Data	16 to 23 only	0-31
Memory Types for Global Data	%G only	%G, %I, %Q, %AI, %AQ, %R
Diagnostics LEDs Software diagnostics	OK, COMM none -	OK, COMM status bits, Fault Reports to Series 90-70 PLC
Ability to pass to host PLC a partial global data message only?	no	yes
Host PLC Scan Impact	slower transfers restricted maximum data	faster transfers potentially more data
Host PLC Program	required	not needed for certain configura- tions
Data Default	no option	may default to 0
Series Six Interface	fixed	selectable

A

Attenuation, A-5

B

Baud Rate

Choosing, 4-4

Conflicting causes COM to blink, 1-2

Baud rate, selection guidelines, 2-6, 4-4

Bus

access, A-7

baud rate, 2-6, 4-4

cable characteristics, 2-6

cable types, 2-5

electrical interface, A-2

general transceiver specifications, A-3

installation, 2-7

length, 2-6

lightning transients, 2-9

noise, effect on data, A-7

outdoors, 2-9

repeaters, using, A-5

serial data format, A-6

surge suppression, 2-9

termination, 2-8

unspecified cable type, using, A-5

using other cable types, 2-6

waveforms, A-4

Bus Noise, 1-2, 2-2

Bus Removal, 2-2

Bus Scan, 3-7

Bus Scan Time, 3-7, 3-11

Bus Token, 3-7

C

Cable types, 2-5

Catalog number, 1-3

Catalog numbers

inline HHM port, 44A736310-001-R001,
2-10

mounting plate, IC660MPH509, 2-12

COMM LED, Blinking, 1-2

Communications Errors, 1-2

Compatibility, 1-3

Configuration

Planning, 4-1

Using a Hand-held Programmer, 4-2

Connector, Hand-held Monitor, 2-10

Control wiring, 2-9

CPU Sweep, 3-8

CRC checking, A-7

D

Device Number, 3-2, 4-3

Device Number conflict, 1-2

Devices on the Bus, 3-4

Disconnecting the Bus, 2-2

D-shell connector, installing, 2-12

E

Environmental Specifications, 1-3

F

Fiber optics, 2-9

G

G Memory, 3-2

GCM module, compared to GCM+, B-1

Genius I/O blocks on bus, 1-1, 3-6

Global Data, 1-3

Global Data Length, 4-5, 4-6

Grounding, 2-9

H

Hand-held Programmer

As part of a system, 1-1

Using for Configuration, 4-2

Hand-held Monitor, connector, 2-10

I

I/O blocks on bus, 1-1, 3-6
Installing the Module, 2-1

L

LEDs, 1-2
Logicmaster 90-70 software, 3-5

M

Memory for Global Data
 in other types of host, 3-4
 in Series 90-30, 3-2
Module Description, 1-2
Module Installation, 2-1

O

OK LED, 1-2

P

Power wiring, 2-9
Program Execution Time, 3-11
Propagation delays, A-5

R

Removing the bus cable, 2-2

Removing the Module, 2-2

S

Series 90-30 PLC, compatibility, 1-3
Series 90-70 PLC, 3-5
Series Five PLC, 3-5
Signal wiring, 2-9
Slot Number, 2-1, 4-3
Specifications, 1-3
Surge suppressors, 2-9

T

Terminal Assembly, 1-2
Terminal Assembly Removal and Installation, 2-3
Terminating the bus, 2-5

V

Vibration and Shock Specifications, 1-3
Voltage attenuation, A-5

W

Wiring Errors, 1-2
Wiring guidelines, 2-9