

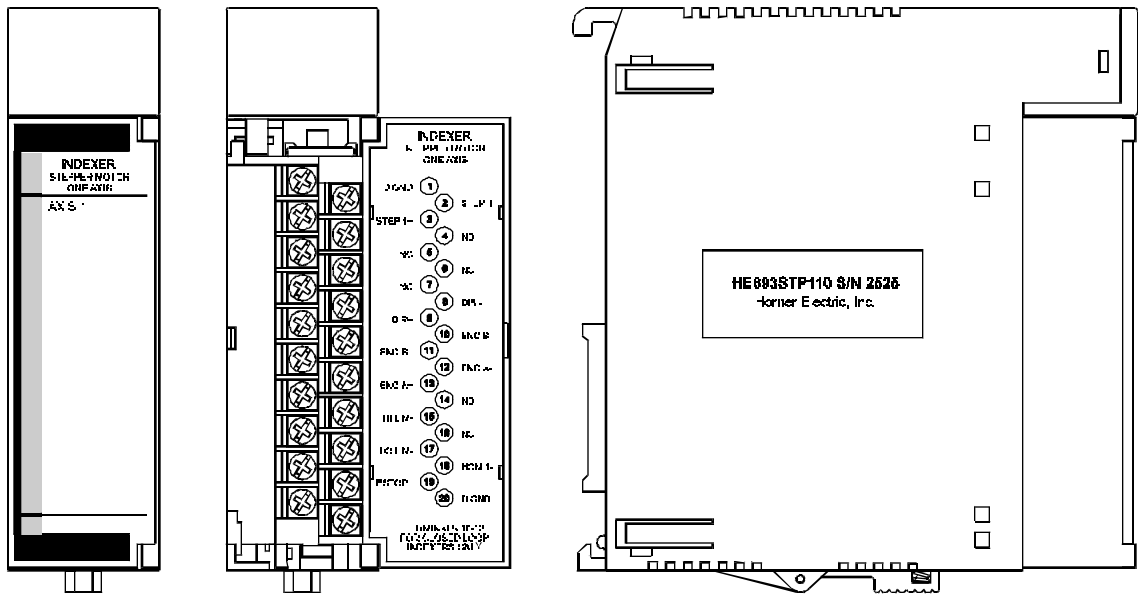

**HORNER
ELECTRIC
ADVANCED
PRODUCTS
GROUP**

Horner Electric's Stepper Positioning Module

for models HE693STPxx0 Revision G or later
AND
models HE693STPxx1 Revision A or later
User's Manual



Horner Electric Advanced Products Group

LIMITED WARRANTY AND LIMITATION OF LIABILITY

Horner Electric, Inc. ("HE") warrants to the original purchaser that the Stepper Positioning Module manufactured by HE is free from defects in material and workmanship under normal use and service. The obligation of HE under this warranty shall be limited to the repair or exchange of any part or parts which may prove defective under normal use and service within two years from the date of manufacture or eighteen (18) months from the date of installation by the original purchaser, whichever occurs first. Such defect to be disclosed to the satisfaction of HE after examination by HE of the allegedly defective part or parts. THIS WARRANTY IS EXPRESSLY IN LIEU OF ALL OTHER WARRANTIES EXPRESSED OR IMPLIED INCLUDING THE WARRANTIES OF MERCHANTABILITY AND FITNESS FOR USE AND OF ALL OTHER OBLIGATIONS OR LIABILITIES AND HE NEITHER ASSUMES, NOR AUTHORIZES ANY OTHER PERSON TO ASSUME FOR HE, ANY OTHER LIABILITY IN CONNECTION WITH THE SALE OF THIS STEPPER POSITIONING MODULE. THIS WARRANTY SHALL NOT APPLY TO THIS STEPPER POSITIONING MODULE OR ANY PART THEREOF WHICH HAS BEEN SUBJECT OF ACCIDENT, NEGLIGENCE, ALTERATION, ABUSE, OR MISUSE. HE MAKES NO WARRANTY WHATSOEVER IN RESPECT TO ACCESSORIES OR PARTS NOT SUPPLIED BY HE. THE TERM "ORIGINAL PURCHASER", AS USED IN THIS WARRANTY, SHALL BE DEEMED TO MEAN THAT PERSON FOR WHOM THE STEPPER POSITIONING MODULE IS ORIGINALLY INSTALLED. THIS WARRANTY SHALL APPLY ONLY WITHIN THE BOUNDARIES OF THE CONTINENTAL UNITED STATES.

In no event, whether as a result of breach of contract, warranty, tort (including negligence) or otherwise, shall HE or its suppliers be liable for any special, consequential, incidental or penal damages including, but not limited to, loss of profit or revenues, loss of use of the products or any associated equipment, damage to associated equipment, cost of capital, cost of substitute products, facilities, services or replacement power, down time costs, or claims of original purchaser's customers for such damages.

To obtain warranty service, return the product to your distributor after obtaining a "Return Material Authorization" (RMA) number. Send the module with a description of the problem, proof of purchase, post paid, insured, in a suitable package.

TABLE OF CONTENTS

PREFACE	Page vi
ABOUT THE PROGRAMMING EXAMPLES	Page vi
COPYRIGHT NOTICE	Page vi
TRADEMARK ACKNOWLEDGMENTS	Page vi
MODULE SPECIFICATIONS	Page vii
CHAPTER 1: INTRODUCTION	Page 1-1
1.1 Stepper Positioning Module (SPM30) Features	Page 1-1
CHAPTER 2: INSTALLATION	Page 2-1
2.1 Module Placement	Page 2-1
2.2 Terminal Wiring	Page 2-1
2.3 LED Indicators	Page 2-3
2.4 Configuring the Series 90-30	Page 2-3
2.4.1 Configuration with Logicmaster 90	Page 2-3
2.4.2 Configuration with the Hand-Held Programmer	Page 2-5
CHAPTER 3: CONTROLLING MOTION.	Page 3-1
3.1 Status Bit Inputs	Page 3-1
3.2 Command Bit Outputs	Page 3-2
3.3 Status Word Inputs	Page 3-3
3.3.1 Motor Position	Page 3-3
3.3.2 Encoder Position	Page 3-4
3.4 Command Word Outputs	Page 3-5
3.4.1 Destination Position.	Page 3-5
3.4.2 Velocity Resolution	Page 3-6
3.4.3 Base Velocity	Page 3-6
3.4.4 Running Velocity	Page 3-7
3.4.5 Acceleration Time	Page 3-7
3.4.6 Deceleration Time	Page 3-8

CHAPTER 4: COMMAND DESCRIPTIONS	Page 4-1
Select Axis	Page 4-2
Find Home Up and Find Home Down	Page 4-3
Jog Up and Jog Down	Page 4-5
Move Relative and Move Absolute	Page 4-6
Resume Move	Page 4-7
Set Current Position	Page 4-8
Clear Error(s)	Page 4-9
Decelerate and Stop	Page 4-10
Immediate Stop	Page 4-11
CHAPTER 5: ENCODER FEEDBACK	Page 5-1
5.1 Encoder Type	Page 5-1
5.2 Step Pulse to Feedback Pulse Ratio	Page 5-2
5.3 Example Ratio Configurations	Page 5-3
5.4 Setting Encoder Tolerance	Page 5-3
APPENDIX A: SAMPLE WIRING DIAGRAMS	Page A-1
APPENDIX B: STPCALC	Page B-1

PREFACE

This manual explains how to use the Horner Electric Stepper Positioning Modules, model numbers HE693STPxx0, revision G or later, and HE693STPxx1, revision A or later for use with GE Fanuc Series 90 and CEGELEC Alspa 8000 family of Programmable Logic Controllers

ABOUT THE PROGRAMMING EXAMPLES

Any example programs and program segments in this manual are included solely for illustrative purposes. Due to the many variables and requirements associated with any particular installation, Horner Electric cannot assume responsibility or liability for actual use based on the examples and diagrams. It is the sole responsibility of the system designer utilizing the Stepper Positioning Module to appropriately design the end system, to appropriately integrate the Stepper Positioning Module and to make safety provisions for the end equipment as is usual and customary in industrial applications as defined in any codes or standards which apply.

COPYRIGHT

This manual is for use with the Horner Electric Stepper Indexer for GE Fanuc Series 90 and CEGELEC Alspa 8000 family of Programmable Logic Controllers.

Copyright (C) 1993, 1994 Horner Electric, Inc., 1521 East Washington Street, Indianapolis Indiana 46201-3899. All rights reserved. No part of this publication may be reproduced, transmitted, transcribed, stored in a retrieval system, or translated into any language or computer language, in any form by any means, electronic, mechanical, magnetic, optical, chemical, manual or otherwise, without the prior agreement and written permission of Horner Electric, Inc.

Information in this document is subject to change without notice and does not represent a commitment on the part of Horner Electric, Inc.

TRADEMARK ACKNOWLEDGEMENTS

Series 90 and Logicmaster are trademarks of GE Fanuc Automation North America Inc.

Alspa 8000 and P8 are Trademarks of CEGELEC

MODULE SPECIFICATIONS

I/O Connector Specifications

PARAMETER	MIN	MAX	UNITS
+5V Power Output (Step/Direction)	-	300	mA
Step Outputs Frequency	DC	245	KHz
Step Outputs High (-20mA)	2.5	-	Vdc
Step Outputs Low (+20mA)	-	0.5	Vdc
Direction Output Setup Time	2	-	mS
Direction Output High (-20mA)	2.5	-	Vdc
Direction Output Low (+20mA)	-	0.5	Vdc
Direction Output High (-60mA, Rev A)	2.5	-	Vdc
Direction Output Low (+60mA, Rev A)	-	0.5	Vdc
Encoder Input Frequency	DC	1.0	MHz
Encoder Single-Ended Threshold	1.2	1.6	Vdc
Encoder Differential Threshold High	-	0.2	Vdc
Encoder Differential Threshold Low	-.2	-	Vdc
Home Inputs Off	12	-	Vdc
Home Inputs On (+1mA)	-	9	Vdc
End Limits Inputs Off	12	-	Vdc
End Limits Inputs On (+1mA)	-	9	Vdc
Emergency Stop Input On	12	-	Vdc
Emergency Stop Input Off (+1mA)	-	9	Vdc

Power Load Specifications

PARAMETER	MIN	MAX	UNITS
+5Vdc (Logic)	200	500	mA
+24Vdc (Relay)	-	0	mA
+24Vdc (Isolated)	-	0	mA

Environmental Specifications

PARAMETER	MIN	MAX	UNITS
Operating Temperature	0	60	°C
Storage Temperature	-40	85	°C
Humidity	5	95	%RH

SECTION 1: INTRODUCTION

Congratulations on your purchase of a Horner Electric Stepper Positioning Module (SPM30)! The SPM30 is an intelligent, programmable motion control option module for the GE Fanuc Series 90-30 Programmable Logic Controller (PLC).

Within a stepper motor control system, the SPM30 acts as a programmable indexer which is capable of interfacing to a wide variety of stepper motor translator drives, limit switches and encoder feedback devices.

In addition, its high maximum step rate and wide dynamic range position control make the SPM30 compatible with microstepping translator drives, for smooth, quiet operation.

1.1 Stepper Positioning Module (SPM30) Features

The Stepper Positioning Module offers a variety of features, including:

- ☑ One and Three Axis (multiplexed) models
- ☑ Up to 245,730 steps (or microsteps) per second
- ☑ Motion may be completely controlled by ladder program
- ☑ Non-volatile memory storage
- ☑ Auto "find home" and manual jogging
- ☑ Moves to relative and/or absolute positions
- ☑ Home and Overtravel inputs
- ☑ Power-up/watchdog timer safety interlock
- ☑ Emergency Stop input
- ☑ Incremental Encoder input (some models)
- ☑ Programmable position, velocity, and acceleration
- ☑ Automatic ramp-down deceleration calculation
- ☑ Trapezoidal and Triangular velocity profiles

SECTION 2: INSTALLATION

2.1 Module Placement

The Stepper Positioning Module may be placed in any I/O module slot of the GE Fanuc Series 90-30 model 311, 321 or 331. The user should **NEVER** insert or remove the Stepper Positioning Module while power is applied to the host PLC. Follow the guidelines defined in the Series 90-30 literature for proper module insertion and removal.

2.2 Terminal Wiring

The Stepper Positioning Module is equipped with a 20 contact removable terminal block. The pinout of the removable terminal block is illustrated on the following page.

Terminals are provided for interfacing the Stepper Positioning Module with a variety of devices, including:

- a) Stepper Motor Drives (Translators),
- b) Incremental encoders (quadrature or up/down)
- c) Mechanical and Proximity type limit switches
- d) E-stop pushbuttons.

The sign (+ or -) after each signal name indicates what state the signal is in when it is active. Active-high is indicated by +, while active-low is indicated by -.

The motor outputs may be connected to translator drives with either differential or single-ended inputs. For single-ended drives, select the motor output whose active signal state (+/-) matches the drive's input.

The encoder inputs may be connected to an encoder with either differential or single-ended outputs. For single-ended encoders, use the active high encoder inputs (ENCODERA+ and ENCODERB+).

The emergency stop input should be connected to terminal 20 via a normally-closed ESTOP switch for normal operation.

PIN	SIGNAL	UNITS	Type
1	D GND	Digital Ground	Diff
2	STEP1-	Axis 1 motor step outputs	Diff
3	STEP1+		Diff
4	STEP2-	Axis 2 motor step outputs	Diff
5	STEP2+		Diff
6	STEP3-	Axis 3 motor step outputs	Diff
7	STEP3+		Diff
8	DIR-	Motor direction outputs	Diff
9	DIR+		Diff
10	ENC B-	Phase B incremental encoder inputs	Diff
11	ENC B+		Diff
12	ENC A-	Phase A incremental encoder inputs	Diff
13	ENC A+		Diff
14	HOM 3-	Axis 3 home input	S.E./Isol
15	HI LIM-	Upper end limit input	S.E./Isol
16	HOM 2-	Axis 2 home input	S.E./Isol
17	LO LIM-	Lower end limit input	S.E./Isol
18	HOM 1-	Axis 1 home input	S.E./Isol
19	ESTOP+	Emergency stop input	S.E./Isol
20	D GND / I GND	Digital Ground or Isolated Ground	S.E./Isol

Figure 2-1. Stepper Positioning Module Terminal Strip Pinout.
(Type: Diff=Differential, S.E./Isol.=Single Ended or Isolated)

2.3 LED Indicators

INDICATOR	COLOR	DESCRIPTION
STOP	Red	Stopped
RAMP	Yellow	Accelerating or decelerating
CNST	Green	Moving at constant velocity

Figure 2-2. Stepper Positioning Module LED Indicators.

2.4 Configuring the Series 90-30

Before any I/O module can be accessed by the Series 90-30, the "makeup" of I/O modules must be defined inside the Series 90-30 CPU. This process is called "configuration". Stepper Positioning Module configuration is supported by Logicmaster 90, version 2.01 or later. Alternatively, the user may configure the Series 90-30 using the Hand-Held Programmer.

2.4.1 Configuration with Logicmaster

The Stepper Positioning Module is programmed in the Logicmaster 90-30 Configuration program as a foreign module. From the main configuration menu, select *I/O Configuration (F1)*, cursor over to the slot containing the module and select *Other (F8)*, and *Foreign (F3)*. The foreign module screen appears (see below).

SOFTWARE CONFIGURATION	
SLOT	FOREIGN MODULE
2	Catalog #: FOREIGN
FRGN	
Module ID :	3
%I Ref Adr :	%I0001 Byte 1 : 00000001 Byte 9 : 00
%I Size :	16 Byte 2 : 00000000 Byte 10 : 00
%Q Ref Adr :	%Q0001 Byte 3 : 00 Byte 11 : 00
%Q Size :	16 Byte 4 : 00 Byte 12 : 00
%AI Ref Adr :	%AI001 Byte 5 : 00 Byte 13 : 00
%AI Size :	2 Byte 6 : 00 Byte 14 : 00
%AQ Ref Adr :	%AQ001 Byte 7 : 00 Byte 15 : 00
%AQ Size :	6 Byte 8 : 00 Byte 16 : 00

Figure 2-3. Logicmaster 90-30 Configuration Foreign Module Screen.

The foreign module screen contains many different parameters. The first column of parameters configures the I/O references allocated to the module. The amount of I/O references required by the module will depend upon its model number. See the following chart:

MODEL	%I	%Q	%AI	%AQ	Byte 1	Byte 2	Byte 3
HE693STP100	16	16	2	6	1	0	0
7HE693STP101				7			
HE693STP110			4	6			
HE693STP111				7			
HE693STP300			2	6			
HE693STP301				7			
HE693STP310			4	6			
HE693STP311				7			

Figure 2-4. I/O Reference and Bytes 1-3 configuration parameters.

The second column of configuration parameters contains a number of additional configuration bytes. The stepper module requires that Byte 1 through Byte 7 be configured. For these parameters, see the chart above for Bytes 1-3, and the chart below for Bytes 4-7.

MODEL	Byte 4	Byte 5	Byte 6	Byte 7
HE693STP100	0	0	0	0
7HE693STP101				
HE693STP110	Encoder Type	Encdr. Multiplier (01-FF)H	Encoder Divisor (01-0F)H	Encdr. Tolerance (00-FF)H
HE693STP111				
HE693STP300	0	0	0	0
HE693STP301				
HE693STP310	Encoder Type	Encoder Multiplier	Encoder Divisor	Encoder Tolerance
HE693STP311				

Figure 2-5. Bytes 4-7 configuration parameters.

Bytes 4-7 are utilized by those indexer models which feature encoder feedback capability. Byte 4 configures the type of encoder used (see Figure 2-6), Byte 5 and 6 set the encoder multiplier and divisor, and Byte 7 sets the encoder tolerance. For details on encoder feedback operation, see Chapter 5.

BYTE 4 VALUE	ENCODER TYPE
0	NONE
1	QUADRATURE
2	UP/DOWN
3	QUAD NO MARKER

Figure 2-6. Bytes 4 values for different encoder types.

2.5.2 Configuration Using the Hand Held Programmer

When utilizing the Hand Held Programmer, select configuration mode. Press the DOWN arrow until the slot containing the stepper module is selected. Press READ, then the ENTER button. One by one, configure the starting %I, %Q, %AI, and %AQ addresses allocated to the module with the numeric and ENTER keys. After completing I/O address configuration, press the RIGHT arrow key to display additional configuration parameters. The first two parameters, "baud rate" and "parity", will not affect module operation; these are for future use only. The "encoder type" parameter is configured using the +/- key and ENTER. The "encoder multiplier", "encoder divisor", and "encoder tolerance" parameters are set using the numeric keys and ENTER.

For additional information on Hand Held Programmer operation, see the *Hand Held Programmer User's Manual* from GE Fanuc, or contact Horner Electric.

CHAPTER 3: CONTROLLING MOTION

The Stepper Positioning Module communicates with the 90-30 CPU via a series of bit type (%I and %Q) and integer type (%AI and %AQ) I/O registers. These registers are assigned to the SPM30 during rack configuration (see Chapter 2). Executing motion control with the 90-30 and the SPM30 is accomplished by properly monitoring and manipulating these bits and words.

These I/O registers can be divided up into four different types; **Status Bits**, **Command Bits**, **Status Words**, and **Command Words**. These registers and their role in the control and monitoring of the SPM30 is described in detail below.

3.1 Status Bit Inputs

The Status Bits are the 16 digital inputs (%I) assigned to the SPM30. The CPU uses the %I status bits to determine what the SPM30 is doing and whether or not an error has occurred. These status bits are summarized in the table below:

POINT	DESCRIPTION
%I1	Emergency Stop Error
%I2	Lower End Limit Error
%I3	Upper End Limit Error
%I4	Illegal Move Error
%I5	Motor Stalled Error
%I6	Future Use
%I7	Future Use
%I8	Power-up/Watchdog Error
%I9	Current Position Valid
%I10	Pre-empted Move Resumable
%I11	Axis 2 Selected
%I12	Axis 3 Selected
%I13	At Home
%I14	Accelerating
%I15	Decelerating
%I16	Moving

Note that the I/O addresses of the bits are listed in the table starting with %I1, but the bits may reside in any 16 consecutive legal %I addresses.

At power-up or after a watchdog timer reset, all status bits will be OFF, except the POWER-UP/WATCHDOG ERROR (%I8) will be ON.

If any of the lower eight bits (%I1 to %I8) is ON, the SPM30 has detected an error condition. These bits will be latched ON until the CLEAR ERROR command (%Q14) is issued. No other commands will be obeyed by the SPM30 while an error bit is ON.

The upper eight bits (%I9 to %I16) reflect various other SPM30 status conditions and are not affected by the CLEAR ERROR command.

3.2 Command Bit Outputs

The Command Bits are the 16 digital outputs (%Q) assigned to the SPM30. The CPU uses the %I status bits to trigger action in the SPM30. These command bits are summarized in the table below:

POINT	DESCRIPTION
%Q1	Select Axis 1
%Q2	Select Axis 2
%Q3	Select Axis 3
%Q4	Find Home Up
%Q5	Find Home Down
%Q6	Jog Up
%Q7	Jog Down
%Q8	Move Relative
%Q9	Move Absolute
%Q10	Resume Move
%Q11	Future Use
%Q12	Future Use
%Q13	Set Current Position
%Q14	Clear Error(s)
%Q15	Decelerate and Stop
%Q16	Immediate Stop

All %Q command bits are OFF to ON edge sensitive. This means that the command will be obeyed only when the SPM30 sees it go from OFF to ON. The SPM30 will always detect this transition in less than one CPU sweep time, thus allowing the use of "one-shots" to trigger commands.

The JOG UP and JOG DOWN commands (%Q6 and %Q7) are unique in that they are also ON to OFF edge sensitive.

Note that since the POWER-UP/WATCHDOG ERROR status bit (%I8) is ON at power-up or after a watchdog timer reset, the CLEAR ERROR command (%Q14) must be issued before any other command may be executed. This is an important safety interlock.

Also, some command bits are ignored depending on the state of other status bits. For example, if the MOVING status bit (%I16) is ON, the only legal command bits are DECELERATE AND STOP (%Q15) and IMMEDIATE STOP (%Q16).

Finally, in the event that more than one legal %Q goes from OFF to ON in the same CPU sweep, the one with the highest %Q number will be obeyed and the others will be ignored. Note that this gives the Immediate Stop command (%Q16) the highest priority.

3.3 Status Word Inputs

SPM30 modules use either two or four %AI status words. All models use %AI1 and %AI2, but %AI3 and %AI4 are used only by SPM30 models which support encoder feedback. These words are described in the table below:

POINT	DESCRIPTION	MINIMUM	MAXIMUM
%AI1	Motor Position (Low Word)	-8,388,608	+8,388,607
%AI2	Motor Position (High Word)		
%AI3	Encoder Position (Low Word)	-8,388,608	+8,388,607
%AI4	Encoder Position (High Word)		

3.3.1 Motor Position

The first two status words (%AI1 and %AI2) are treated as a single 32-bit signed integer value representing the MOTOR POSITION for the selected axis.

MOTOR POSITION is continuously updated (up or down) based on step pulses sent by the SPM30 to the stepper motor translator drive.

Note that at power-up or after a watchdog timer reset, this value will be set to zero and is considered invalid. This is reflected by the fact that the CURRENT POSITION VALID status bit is OFF.

The MOTOR POSITION will continue to be invalid until a FIND HOME UP (%Q4), FIND HOME DOWN (%Q5) or SET CURRENT POSITION (%Q13) command is executed successfully. Until this happens, the SPM30 will not obey the MOVE ABSOLUTE command (%Q9).

Note also, that MOTOR POSITION may become invalid again if motion stops suddenly, as a result of EMERGENCY STOP ERROR (%I1), LOWER END LIMIT ERROR (%I2), UPPER END LIMIT ERROR (%I3), MOTOR STALLED ERROR (%I5) or IMMEDIATE STOP command (%Q16).

3.3.2 Encoder Position

For SPM30 models which support encoder feedback, the %AI3 and %AI4 status words are treated as a single 32-bit signed integer value representing the ENCODER POSITION for Axis 1.

ENCODER POSITION is continuously updated (up or down) based on feedback pulses sent by the encoder to the SPM30, regardless of which axis is currently selected.

Note that at power-up or after a watchdog timer reset, this value will be set to zero and is considered invalid. This is reflected by the fact that the CURRENT POSITION VALID status bit is OFF.

If the SPM30 is properly configured (see Chapter 5), ENCODER POSITION will track Axis 1's MOTOR POSITION.

Note that when ENCODER POSITION doesn't match MOTOR POSITION exactly, a position validation error has been detected. There are several possible causes for this error (see Chapter 5).

Some position validation errors can't be avoided, which is why the SPM30 supports an error tolerance configuration parameter (ENCODER TOL).

3.4 Command Word Outputs

The %AQ command words are qualifiers for the %Q command bits. The words and their minimum and maximum values are detailed in the chart below:

POINT	DESCRIPTION	MINIMUM	MAXIMUM
%AQ1	Destination Position (Low Word)	-8,388,608	+8,388,607
%AQ2	Destination Position (High Word)		
%AQ3	Velocity Resolution	20	65,535
%AQ4	Base Velocity	1	8,190
%AQ5	Running Velocity	2	8191
%AQ6	Acceleration Time (mS)	1	27300
%AQ7	Deceleration Time (mS)	0	27,300

Typically, the %AQ command words are set to appropriate values and then one of the %Q command bits is changed from OFF to ON.

On the CPU sweep following the one in which the %Q was transitioned from OFF to ON, the %AQ command words may be changed to prepare for the next move without affecting the move in progress.

The exception to this rule is, that the DESTINATION POSITION must not be disturbed during a FIND HOME UP or a FIND HOME DOWN command, until either an error occurs or the CURRENT POSITION VALID status bit goes ON.

3.4.1 Destination Position

The first two command words (%AQ1 and %AQ2) are treated as a single 32-bit signed integer value representing the DESTINATION POSITION for the selected axis.

For the FIND HOME UP, FIND HOME DOWN and SET CURRENT POSITION commands, the DESTINATION POSITION is the value to be loaded into MOTOR POSITION when the command completes successfully.

For the MOVE ABSOLUTE command, the DESTINATION POSITION is the absolute position to move to.

For the MOVE RELATIVE command, the DESTINATION POSITION is the relative distance to move above or below "wherever we are now".

3.4.2 Velocity Resolution

This command word determines the resolution of the BASE VELOCITY (%AQ4) and the RUNNING VELOCITY (%AQ5) command words.

The selectable resolutions range from .01 pulses per second to 30 pulses per second according to the following formula:

$$\text{VELOCITY RESOLUTION} = \frac{600}{\%AQ3} \quad \text{[pulses per second]}$$

The following table shows some useful %AQ3 settings along with the resulting velocity resolution and maximum velocity:

%AQ3	Velocity Resolution	Maximum Velocity
20	30.0 pulses per second	245,730.0 pulses per second
60	10.0 pulses per second	81,910.0 pulses per second
120	5.0 pulses per second	40,995.0 pulses per second
300	2.0 pulses per second	16,382.0 pulses per second
600	1.0 pulses per second	8,191.0 pulses per second
1200	0.5 pulses per second	4,095.5 pulses per second

3.4.3 Base Velocity

This command word determines the velocity the SPM30 starts at when executing one of the motion commands (%Q4 through %Q10).

A typical move will start at the BASE VELOCITY and accelerate to the RUNNING VELOCITY. Then, if the move ends normally, it will decelerate from RUNNING VELOCITY to BASE VELOCITY, and then stop.

Also, near the end of a FIND HOME UP or FIND HOME DOWN command, the motor will move at a constant BASE VELOCITY while searching for the exact home position.

BASE VELOCITY depends on VELOCITY RESOLUTION (%AQ3) and is calculated according to the following formula:

$$\text{BASE VELOCITY} = \%AQ4 \times \frac{600}{\%AQ3} \quad [\text{pulses per second}]$$

3.4.4 Running Velocity

This command word determines the maximum velocity the motor will be moving after the SPM30 finishes accelerating.

The RUNNING VELOCITY must be greater than the BASE VELOCITY.

RUNNING VELOCITY depends on VELOCITY RESOLUTION (%AQ3) and is calculated according to the following formula:

$$\text{RUNNING VELOCITY} = \%AQ5 \times \frac{600}{\%AQ3} \quad [\text{pulses per second}]$$

3.4.5 Acceleration Time

This command word determines the maximum time spent accelerating from the BASE VELOCITY to the RUNNING VELOCITY during a move.

If the move ends normally, this same amount of time is spent decelerating from the RUNNING VELOCITY to the BASE VELOCITY before stopping.

Note that if the move is halfway done before acceleration to the RUNNING VELOCITY is complete, the SPM30 will start decelerating right away. In this case, the acceleration and deceleration times are decreased and the velocity profile becomes triangular.

Also note that the maximum useful value for ACCELERATION TIME is dependent on the BASE VELOCITY (%AQ4) and RUNNING VELOCITY (%AQ5) according to the following formula:

$$\text{MAXIMUM USEFUL \%AQ6} = \frac{\%AQ5 - \%AQ4}{0.3} \quad [\text{milliseconds}]$$

3.4.6 Deceleration Time

This command word determines the maximum time spent decelerating from the RUNNING VELOCITY to the BASE VELOCITY during a move.

Also note that the maximum useful value for DECELERATION TIME is dependent on the BASE VELOCITY (%AQ4) and RUNNING VELOCITY (%AQ5) according to the same formula as used with acceleration.

Note that only models HE693STPxx1 allow for independent control of acceleration time and deceleration time.

If the deceleration time is set to 0, the module will automatically set the actual deceleration time equal to the acceleration time.

CHAPTER 4: COMMAND DESCRIPTIONS**COMMAND DESCRIPTIONS**

These pages describe the commands in more detail. Each command description includes the following information:

- (1) Command Name
- (2) Command Bit(s)
- (3) Status Bits Required
- (4) Status Bits Affected
- (5) Status Words Required
- (6) Status Words Affected
- (7) Command Words Required
- (8) Command Description

SELECT AXIS

Command Numbers:	%Q1, %Q2, %Q3
Status Bits Required:	%I1 thru %I8 and %I16 must be OFF
Status Bits Affected:	%I9 and %I13
Status Words Required:	%AI1, %AI2
Status Words Affected:	%AI1, %AI2
Command Words Required:	None

Command Description:

These commands are used to select a new axis to be acted upon by the other commands as follows:

%Q1	Selects axis 1 to be the new current axis
%Q2	Selects axis 2 to be the new current axis
%Q3	Selects axis 3 to be the new current axis

At power-up or after a watchdog timer reset, axis 1 is selected by default. %Q2 and %Q3 are illegal commands for the STP100 and STP110 (1 axis models).

When a new axis is selected, the following sequence takes place:

- (1) If requested new axis is the same as the old axis or is illegal, do nothing.
- (2) Otherwise, save old axis' MOTOR POSITION, CURRENT POSITION VALID and AT HOME status,
- (3) Set axis multiplexer for the new axis,
- (4) Restore last known MOTOR POSITION, CURRENT POSITION VALID and AT HOME status for the new axis,
- (5) If the new axis' AT HOME status has changed since the last time it was selected, its CURRENT POSITION VALID status is turned OFF.

FIND HOME UP and FIND HOME DOWN

Command Numbers:	%Q4, %Q5
Status Bits Required:	%I1 thru %I8 and %I16 must be OFF
Status Bits Affected:	%I1 thru %I5, %I9, %I13 thru %I16
Status Words Required:	None
Status Words Affected:	%AI1 thru %AI4
Command Words Required:	%AQ1 thru %AQ6

Command Description:

These commands are used to start a search for the current axis' home reference position as follows:

%Q4	Searches for home in the UP direction
%Q5	Searches for home in the DOWN direction

When searching for home, the following sequence takes place:

- (1) CURRENT POSITION VALID status is turned OFF,
- (2) The current axis is moved normally (starts at BASE VELOCITY and accelerates to RUNNING VELOCITY) in the selected direction,
- (3) When the axis' home input becomes active, motion is stopped immediately,
- (4) Then, just in case we shot right past home, the axis is run at the BASE VELOCITY in the opposite direction till the home input becomes active again,
- (5) Motion then continues in the same direction as step (4) above, (still at the BASE VELOCITY), till the home input is inactive for 50 mS,
- (6) Then the direction is reversed again, and the axis is moved at the BASE VELOCITY till the home input is active at which time the axis stops precisely AT HOME,
- (7) DESTINATION POSITION is copied into MOTOR POSITION (and into EN CODER POSITION if axis 1 is selected) and CURRENT POSITION VALID status bit is turned ON.

FIND HOME UP and FIND HOME DOWN (cont'd)

Command Description - (cont'd):

If the current axis is axis 1, and the ENCODER configuration parameter is set to QUAD, there is a slight variation in step (3) of the above sequence as follows:

- (3) When the axis' End Limit input for the current direction becomes active, motion is stopped immediately,

This variation assumes the encoder's marker output is to be used as axis 1's home input (see later chapter for more information on the use of encoder feedback devices).

Since the marker output on a rotary encoder typically occurs several times during a full stroke move, this technique allows the marker which occurs closest to the limit switch to be used as the home position.

For best results, the marker to limit switch relationship should be mechanically adjusted such that the marker occurs at approximately half of an encoder revolution away from the limit switch.

JOG UP and JOG DOWN

Command Numbers:	%Q6, %Q7
Status Bits Required:	%I1 thru %I8 and %I16 must be OFF
Status Bits Affected:	%I1 thru %I5, %I13 thru %I16
Status Words Required:	None
Status Words Affected:	%AI1 thru %AI4
Command Words Required:	%AQ3 thru %AQ6

Command Description:

These commands are used to perform manual jogging on the current axis as follows:

%Q6	Starts a manual jog move in the UP direction
%Q7	Starts a manual jog move in the DOWN direction

When one of the jog command bits goes ON, the current axis starts in the selected direction at the BASE VELOCITY and accelerates to the RUNNING VELOCITY.

The axis will continue moving at the RUNNING VELOCITY until the jog command bit goes OFF. At that time, the axis will decelerate to the BASE VELOCITY and then stop.

If the jog command bit goes OFF before the axis has reached RUNNING VELOCITY, acceleration and deceleration times will be decreased and the velocity profile becomes triangular.

MOVE RELATIVE and MOVE ABSOLUTE

Command Numbers:	%Q8, %Q9
Status Bits Required:	%I1 thru %I8 and %I16 must be OFF; %I9 must be ON for %Q9 command
Status Bits Affected:	%I1 thru %I5, %I10, %I13 thru %I16
Status Words Required:	%AI1, %AI2 required for %Q9 command
Status Words Affected:	%AI1 thru %AI4
Command Words Required:	%AQ1 thru %AQ6

Command Description:

These commands are used to perform relative or absolute moves on the current axis as follows:

%Q8	Performs a relative move
%Q9	Performs an absolute move

These commands perform a programmed move up or down to a relative target position.

If doing a relative move, the relative target position is taken directly from DESTINATION POSITION and it IS NOT necessary for CURRENT POSITION VALID to be ON.

If doing an absolute move, the relative target position is calculated as the difference between the DESTINATION POSITION and the MOTOR POSITION and therefore it IS necessary for CURRENT POSITION VALID to be ON.

Normally the move will start at the BASE VELOCITY and accelerate to the RUNNING VELOCITY until it is time to decelerate back down to the BASE VELOCITY and then stop. This type of move is said to have a trapezoidal velocity profile.

If the move gets halfway to its relative target position before accelerating to the RUNNING VELOCITY, the SPM3030 will start decelerating at that point. In this case, the acceleration and deceleration times are decreased and the velocity profile becomes triangular.

RESUME MOVE

Command Number:	%Q10
Status Bits Required:	%I1 thru %I8 and %I16 must be OFF; %I10 must be ON
Status Bits Affected:	%I1 thru %I5, %I10, %I13 thru %I16
Status Words Required:	None
Status Words Affected:	%AI1 thru %AI4
Command Words Required:	None

Command Description:

This command resumes a previously pre-empted relative or absolute move.

If a MOVE RELATIVE or MOVE ABSOLUTE command was previously pre-empted by a DECELERATE AND STOP command, and no other commands have been issued since then, the PRE-EMPTED MOVE RESUMABLE status bit will be ON.

In this case, the RESUME MOVE command can be issued to restart the pre-empted move from where it left off. Of course, this action will turn the PRE-EMPTED MOVE RESUMABLE status bit back OFF.

Note that the resume logic is such that a move may be pre-empted and resumed any number of times until one of the following occurs:

- (1) The move reaches its originally programmed relative target position,
- (2) An error occurs (such as end limit or emergency stop),
- (3) Some command other than %Q10 is issued after the move is pre-empted.

The RESUME MOVE command is especially useful for "manually assisted programmed moves". For example, the machine operator may trigger a MOVE ABSOLUTE command by pressing a footswitch. If he continues to press the footswitch, the move will continue until it reaches its programmed target position.

However, at the operator's option, he may release the footswitch causing a DECELERATE AND STOP command to be issued. There are a number of reasons why he might decide to do this, such as to make a mechanical adjustment or to manually reposition the material being moved.

Then, when he's ready, he may press the footswitch again sending a RESUME MOVE command to the SPM30 to complete the motion.

SET CURRENT POSITION

Command Number:	%Q13
Status Bits Required:	%I1 thru %I8 and %I16 must be OFF
Status Bits Affected:	%I9
Status Words Required:	None
Status Words Affected:	%AI1 thru %AI4
Command Words Required:	%AQ1, %AQ2

Command Description:

This command is used to manually set the current position for the current axis.

When this command is issued, DESTINATION POSITION is copied into MOTOR POSITION (and into ENCODER POSITION if axis 1 is selected) and CURRENT POSITION VALID status bit is turned ON.

This command can be used in conjunction with the JOG UP and JOG DOWN commands as an alternative to the FIND HOME UP and FIND HOME DOWN commands for finding and setting a reference position.

CLEAR ERROR(S)

Command Number:	%Q14
Status Bits Required:	None
Status Bits Affected:	%I1 thru %I8
Status Words Required:	None
Status Words Affected:	None
Command Words Required:	None

Command Description:

This command is used to clear errors previously detected by the SPM30.

When this command is issued, all error status bits (%I1 thru %I8) are turned OFF.

Note that when an error status bit is ON, the SPM30 will not obey any other commands till the error is cleared via the CLEAR ERROR(S) command.

This logic also acts as a safety interlock, since the POWER-UP/WATCHDOG error status bit is always set after the SPM30 is reset due to power-up or watchdog timer reset.

DECELERATE AND STOP

Command Number:	%Q15
Status Bits Required:	None
Status Bits Affected:	%I10, %I13 thru %I16
Status Words Required:	None
Status Words Affected:	%AI1 thru %AI4
Command Words Required:	None

Command Description:

This command is used to cause the current axis to decelerate and stop.

When this command is issued, the current axis will decelerate until it reaches the BASE VELOCITY and then it will stop.

If this command pre-empts a MOVE RELATIVE or MOVE ABSOLUTE command, the PRE-EMPTED MOVE RESUMABLE status bit is turned ON unless an error occurred.

In this case, the original move may be resumed from where it left off via the RESUME command.

IMMEDIATE STOP

Command Number:	%Q16
Status Bits Required:	None
Status Bits Affected:	%I9, %I13 thru %I16
Status Words Required:	None
Status Words Affected:	%AI1 thru %AI4
Command Words Required:	None

Command Description:

This command is used to cause the current axis to stop immediately.

When this command is issued, the current axis will stop as quickly as possible.

If the axis was moving, the CURRENT POSITION VALID status bit is turned OFF.

CHAPTER 5:ENCODER FEEDBACK

SPM30 models which support encoder feedback, may be configured for a variety of incremental encoder feedback options for axis 1.

The type of encoder used and the relationship of the SPM30 step pulses to the encoder feedback pulses are set via the encoder type, encoder multiplier, encoder divisor, and encoder tolerance configuration parameters.

5.1 Encoder Type

First of all, the type of encoder used is determined by the ENCODER configuration parameter as follows:

ENCODER	Description
NONE	No encoder feedback
QUAD	Incremental quadrature encoder feedback with marker as home input
U/D	Incremental up/down encoder feedback
QUAD N/M	Incremental quadrature encoder feedback without marker as home input

If the encoder type is configured to NONE, the ENCODER POSITION status registers (%AI3 and %AI4) will always match axis 1's MOTOR POSITION and the MOTOR STALLED ERROR (%I5) will never go ON.

Otherwise, if the encoder type is configured for QUAD (or QUAD N/M) or U/D, the ENCODER POSITION status registers are updated as a result of feedback pulses from the encoder to the SPM30, thus allowing MOTOR POSITION validation and motor stall detection.

The quadrature encoder is the most common position feedback device used in motion control. This type of encoder outputs two square wave signals (A and B) which are 90 degrees out of phase from each other. The SPM30 determines the direction of motion based on which signal lags behind the other.

A third signal, called a marker, is also provided by some quadrature encoders. This signal occurs once per revolution and is used as a "reference location" which may be connected to the SPM30's Home 1- input. If the marker signal is to be connected to the home input, the encoder type should be QUAD, *and* a marker signal converter must be used (contact Horner Electric). See Chapter 4 for a description of the FIND HOME UP and FIND HOME DOWN commands.

Also, a quadrature encoder's resolution can be effectively doubled or quadrupled by the SPM30's quadrature decoding hardware.

If the ENCODER type is configured for U/D, the SPM30's phase A input becomes a "count up" input and phase B becomes a "count down" input.

The U/D mode is especially useful for unidirectional motion control in which some mechanical event provides the feedback, such as a proximity detector monitoring gear teeth.

5.2 Step Pulse to Feedback Pulse Ratio

In order to use encoder feedback for MOTOR POSITION validation, it is necessary to know the ratio of SPM30 step pulses to encoder feedback pulses.

STEP RESOLUTION, specified in microsteps per revolution, indicates the number of step pulses which must be sent by the SPM30 to the translator drive, to move the stepper motor one revolution. This value is determined by the translator drive and is switch or jumper selectable on some drives.

ENCODER RESOLUTION, specified in lines per revolution, indicates the number of feedback pulses the encoder sends to the SPM30 during one revolution of motion. This value is determined by the encoder itself.

For a given STEP RESOLUTION and ENCODER RESOLUTION, the following formula may be used to determine the proper settings for the ENCODER MLT and ENCODER DIV configuration parameters:

$$\frac{\text{ENCODER MLT}}{\text{ENCODER DIV}} = \frac{\text{STEP RESOLUTION}}{\text{ENCODER RESOLUTION}}$$

Where: ENCODER MLT is any value from 1 to 255
ENCODER DIV is any value from 1 to 16

If more than one combination of ENCODER MLT and ENCODER DIV will satisfy the formula, choose the combination with the lowest values for ENCODER MLT and ENCODER DIV (reduce the fraction).

5.3 Example Ratio Configurations

Lets assume we have a two-phase quadrature, incremental rotary encoder, with an ENCODER RESOLUTION of 1000 lines per revolution.

Lets further assume the encoder is mechanically connected to the stepper motor shaft, and is electrically connected to the SPM30's Phase A and B incremental encoder inputs.

The following table shows the proper configuration settings for ENCODER MLT and ENCODER DIV for 16 typical STEP RESOLUTIONS:

STEP RESOLUTION	ENCODER MLT	ENCODER DIV	STEP RESOLUTION	ENCODER MLT	ENCODER DIV
200	1	5	20000	20	1
400	2	5	21600	108	5
1000	1	1	25000	25	1
2000	2	1	25400	127	5
5000	5	1	25600	128	5
10000	10	1	36000	36	1
12800	64	5	50000	50	1
18000	18	1	50800	254	5

5.4 Setting Encoder Tolerance

When an encoder feedback device is connected to the SPM30, it can be used to verify successful execution of axis 1 motion commands.

In an ideal control loop, ENCODER POSITION and MOTOR POSITION would always match exactly.

However, when ENCODER POSITION and MOTOR POSITION become skewed, it means that one or more of the following errors have occurred:

1. A change in direction produced a "backlash error" caused by the mechanical linkage between the motor and the encoder.

2. A "resolution error" has occurred because the encoder is less precise than the microstep rate (STEP RESOLUTION is higher than the ENCODER RESOLUTION).
3. The STEP RESOLUTION exceeds the motor's ability to accurately position its rotor. (Most motors have an absolute step accuracy of about 1 part in 2000 which means a STEP RESOLUTION higher than 2000 only contributes to motor smoothness.)
4. The motor missed some step pulses, or stalled, because of low or mid-frequency resonance.
5. The motor missed some step pulses, or stalled, because the programmed ACCELERATION TIME was too low for the inertial load.
6. Some external force changed the motor's position.

The SPM30 can be configured to use encoder feedback pulses, to automatically detect position errors, and motor stalling. This is accomplished via the encoder tolerance configuration parameter.

If encoder tolerance is zero, automatic position error detection is disabled and the MOTOR STALLED ERROR will never go ON.

Otherwise, encoder tolerance may be set to a number between 1 and 255 indicating the position error magnitude which will cause CURRENT POSITION VALID to be turned OFF.

In this case, when the absolute value of the difference between MOTOR POSITION and ENCODER POSITION reaches encoder tolerance, the CURRENT POSITION VALID status bit will be turned OFF.

Also, when ENCODER TOL is non-zero, the SPM30 uses the encoder feedback pulses to verify motor velocity during motion. This allows the SPM30 to detect a stalled motor regardless of how fast the motor is "supposed" to be moving.

When the SPM30 detects a stalled motor, the MOTOR STALLED ERROR is turned ON and motion is stopped immediately.

This page was intentionally left blank.

APPENDIX A: SAMPLE WIRING DIAGRAMS

A1 TRANSLATOR DRIVE CONNECTION

The Stepper Indexer Module is compatible with translator drives which accept signal levels of 5V. These include TTL level signals (5V single-ended, negative or positive active) and Line driver signals (5V, differential). The following three diagrams illustrate the connection of the stepper indexer module to translator drives of the abovementioned types. These diagrams illustrate connection for the "step" (pulse) and "direction" (forward/reverse) signals.

5V Line Driver

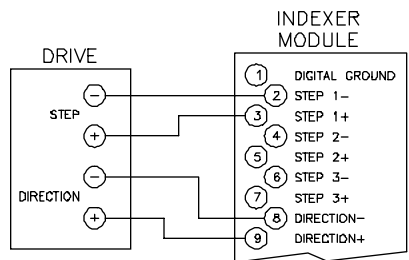

5V Positive Active

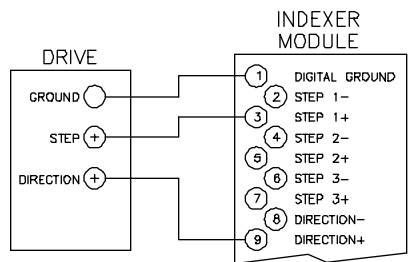

5V Negative Active

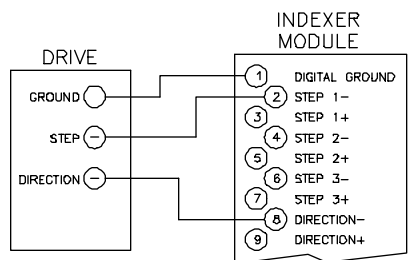

A2. ENCODER FEEDBACK CONNECTION

The Stepper Indexer Module is compatible with incremental encoders which output either a 5V line driver (differential) or 5V positive active (single-ended) signal. Some encoders feature a "marker" pulse. This signal may be used as a "home" input if a signal converter is used. This signal converter is available from Horner Electric. It converts the Home 1- input terminal from negative active to positive active.

5V Line Driver

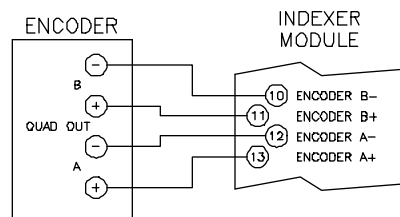

5V Positive Active

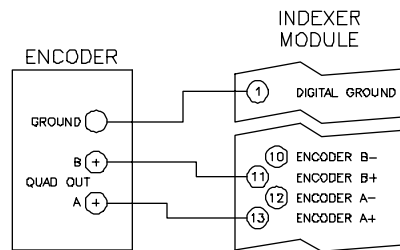

A3 HOME, END LIMIT AND EMERGENCY STOP INPUTS (SWITCH INPUTS)

The Stepper Indexer Module allows real world switches (limit, proximity, mechanical, etc.) to be connected to the module. This enhances the ability of the overall stepper control system to find home position accurately and to quickly stop motion in the event of an emergency situation.

The Stepper Models HE693STPxx0 allow mechanical switches, proximity switches, limit switches, etc. to be connected to the module. Optical isolation is *not* provided, thus the common for these switch inputs (terminal 20 on the terminal strip) is designated "digital ground", electrically equivalent to the common for the step and direction outputs of the module. For these non isolated models, switches must be selected which are compatible with 5V signal levels, and great care must be taken to ensure that noise is not picked up by the wiring run from these switches to the module terminal strip. Preventative steps may include separate conduit, and/or shielded wiring. If the switches selected require power, this must be provided externally.

The Stepper Indexer models HE693STPxx1 provide optical isolation for the switch inputs. Optical isolation is provided, thus the common for the switch inputs is designated "isolated ground", isolated from the common for the step and direction outputs. Switches may be selected which are compatible with 12 or 24V signal levels. If proximity type switches are used, they must be of the NPN type. The voltage required to power the switches (if needed) must be provided externally.

Home, End Limit, and Emergency Stop Inputs

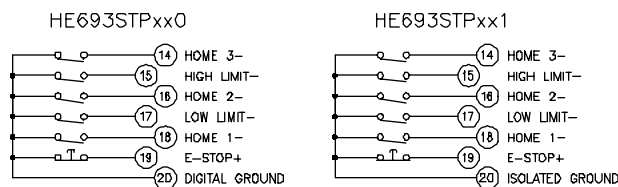

Equivalent Circuit (circuitry within dotted lines internal to module)

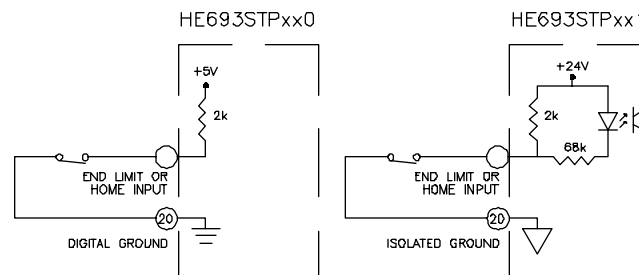

Electrical Connection for Mechanical Switches

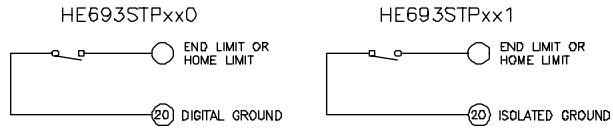

Electrical Connection for Proximity Switches

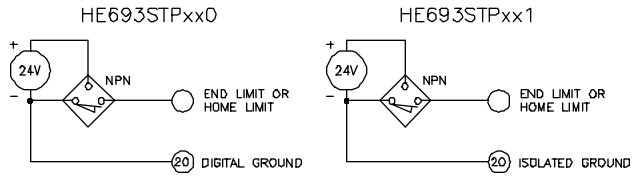

APPENDIX B: STEPPER CALCULATOR

B1.1 STPCALC

In addition to the LogicMaster™ 90 example folder, the STEPEXAM disk contains the STPCALC.EXE executable file.

STPCALC.EXE can be used to predict motion profiles which will result from particular sets of HE693STPXXX %AQ parameter values loaded by the user's ladder program.

B1.2 Entering Parameters

When STPCALC is started, it prompts for the entry of 6 parameters. These parameters correspond to the values which would be loaded in the stepper module's %AQ registers to define a move.

B1.2.1 Enter total pulses (0 to 16777215) :

This parameter corresponds to the module's %AQ1 and %AQ2 double-word register (destination position) and is the total number of step pulses for a particular move. Since some moves (e.g. jog up / jog down) have no specific destination, this parameter is optional.

If this parameter is entered, it should be unsigned, since all calculations performed by STPCALC are independent of the move's direction.

Note that "legal" values accepted by the module for this parameter range from -8,388,608 to +8,388,607. Therefore, the maximum "relative move" would be 8,388,608 pulses, while the maximum "absolute move" would be 16,777,215 pulses. Note that this value is input without commas.

B1.2.2 Enter velocity resolution (20 to 65535) :

This parameter corresponds to the module's %AQ3 register and determines the value (in pulses per second) of each count of the base velocity and running velocity parameters.

This parameter is actually a "velocity divisor" which results in selectable velocity resolutions ranging from .01 pulses per second to 30 pulses per second. The following table shows some useful %AQ settings along with the resulting velocity resolution and maximum velocity.

%AQ3	Velocity Resolution	Maximum Velocity
20	30.0 pulses per second	245,730.0 pulses per second
60	10.0 pulses per second	81,910.0 pulses per second
120	5.0 pulses per second	40,995.0 pulses per second
300	2.0 pulses per second	16,382.0 pulses per second
600	1.0 pulses per second	8,191.0 pulses per second
1200	0.5 pulses per second	4,095.5 pulses per second

B1.2.3 Enter base velocity (1 to 8190) :

This parameter corresponds to the module's %AQ4 register and determines the velocity (in pulses per second) the module starts at when a move begins.

B1.2.4 Enter running velocity (X to 8191) :

This parameter corresponds to the module's %AQ5 register and determines the maximum velocity (in pulses per second) the motor will be moving after accelerating.

The running velocity must be greater than the base velocity.

B1.2.5 Enter acceleration mS (X to YYYYY) :

This parameter corresponds to the module's %AQ6 register and determines the maximum time spent accelerating from the base velocity to the running velocity at the start of a move.

This parameter will always be in the range 1 to 27300 but its actual minimum and maximum values depend on the values previously entered for velocity resolution, base velocity and running velocity.

B1.2.6 Enter deceleration mS (X to YYYYY) :

This parameter corresponds to the module's %AQ7 register and determines the maximum time spent decelerating from the running velocity to the base velocity at the end of a move.

This parameter will always be in the range 1 to 27300 but its actual minimum and maximum values depend on the values previously entered for velocity resolution, base velocity and running velocity.

When using STPCALC for a module which does not support separate deceleration control, enter the same value as was entered for acceleration time.

B1.3 Calculated Values

After the 6 motion parameters have been entered, STPCALC performs calculations to determine the corresponding motion profile and then displays the results.

These results help the system designer determine the expected motions for specific sets of %AQ parameters. The calculated results are described in the following sections.

B1.3.1 Actual acceleration rate =

This value is the actual acceleration rate ($Rate_A$) in pulses per second² and is calculated in two steps as follows:

$$Z_A = \frac{AQ6 \times 24576}{(AQ5 - AQ4) \times 5} \quad (\text{Rounded up to the nearest integer})$$

$$Rate_A = \frac{4915200 \times 600}{Z_A \times AQ3} \quad (\text{pulses per second}^2)$$

B1.3.2 Actual deceleration rate =

This value is the actual deceleration rate ($Rate_D$) in pulses per second² and is calculated in two steps as follows:

$$Z_D = \frac{AQ7 \times 24576}{(AQ5 - AQ4) \times 5} \quad (\text{Rounded up to the nearest integer})$$

$$Rate_D = \frac{4915200 \times 600}{Z_D \times AQ3} \quad (\text{pulses per second}^2)$$

B1.3.3 Actual velocity resolution =

This value is the actual velocity resolution (Vel_Res) in pulses per second and is calculated as follows:

$$Vel_Res = \frac{600}{AQ3} \quad (\text{pulses per second})$$

The table in section B1.2.2 shows some useful %AQ settings along with the resulting velocity resolution and maximum velocity:

B1.3.4 Actual base velocity =

This value is the actual base velocity (Vel_B) in pulses per second and is calculated as follows:

$$Vel_B = AQ4 \times \frac{600}{AQ3} \quad (\text{pulses per second})$$

B1.3.5 Actual running velocity =

This value is the actual running velocity (Vel_R) in pulses per second and is calculated as follows:

$$Vel_R = AQ4 \times \frac{600}{AQ3} \quad (\text{pulses per second})$$

Note that if the total pulses parameter is too short to accommodate the acceleration time and deceleration time parameters, the motor will never reach the running velocity and the move will become triangular. When this happens, actual peak velocity is calculated and displayed instead of running velocity.

B1.3.6 Actual peak velocity =

For triangular moves, this value is the actual peak velocity (Vel_P) in pulses per second and is calculated as follows:

$$Vel_P = \frac{Rate_A \times Time_A}{1000} + Vel_B \quad (\text{pulses per second})$$

For the definitions of $Rate_A$, $Time_A$ and Vel_B see sections B1.3.1, B1.3.11 and B1.3.4 respectively.

B1.3.7 Actual acceleration pulses =

This value is the actual number of acceleration pulses ($Pulse_A$) and is calculated as follows for trapezoidal moves:

$$Pulse_A = \frac{(AQ5 - AQ4) \times (AQ5 + AQ4 + 1) \times Z_A}{16384 \times AQ3} \quad (\text{pulses})$$

For the definition of Z_A see section B1.3.1.

For a triangular move, $Pulse_A$ is multiplied by the ratio R_T before being displayed, as described in the next section.

B1.3.8 Actual running pulses = (pulses at full speed)

If a value was entered for total pulses ($Pulse_{TOT}$ section 1.2.1), this value is displayed as the actual number of running pulses ($Pulse_R$) and is calculated as follows for trapezoidal moves:

$$Pulse_R = Pulse_{TOT} - Pulse_A - Pulse_D \quad (\text{pulses})$$

$Pulse_{TOT}$ is the total pulses parameter as described in B1.2.1. For the definitions of $Pulse_A$ and $Pulse_D$ see section B1.3.7 and B1.3.9 respectively.

If the resulting value for $Pulse_R$ is negative, running velocity is never reached and the move is triangular. In this case, $Pulse_R$ is displayed as zero and $Pulse_A$ and $Pulse_D$ are multiplied by the following ratio (R_T) before being displayed.

$$R_T = \frac{Pulse_{TOT}}{Pulse_A + Pulse_D}$$

B1.3.9 Actual deceleration pulses =

This value is the actual number of deceleration pulses ($Pulse_D$) and is calculated as follows for trapezoidal moves:

$$Pulse_D = \frac{(AQ5 - AQ4) \times (AQ5 + AQ4 + 1) \times Z_D}{16384 \times AQ3} \quad (\text{pulses})$$

For the definition of Z_D see section B1.3.2.

For a triangular move, $Pulse_D$ is multiplied by the ratio R_T before being displayed, as described in the previous section.

B1.3.10 Actual total acc/dec pulses =

If a value was not entered for total pulses (section B1.2.1), this value is displayed as the total number of acc/dec pulses ($Pulse_{A+D}$) and is calculated as follows:

$$Pulse_{A+D} = Pulse_A + Pulse_D \quad (\text{pulses})$$

B1.3.11 Actual acceleration time =

This value is the actual acceleration time ($Time_A$) and is calculated as follows for trapezoidal moves:

$$Time_A = \frac{(AQ5 - AQ4) \times Z_A \times 5}{24576} \quad (\text{mS})$$

For the definition of Z_A see section B1.3.1.

For a triangular move, $Time_A$ is multiplied by the ratio R_T (described in section B1.3.8) before being displayed and before being used to calculate peak velocity (section B1.3.6).

B1.3.12 Actual running time = (time at full speed)

This value is the actual running time ($Time_R$) and is displayed only if a value was entered for total pulses (section B1.2.1). This value is calculated as follows for trapezoidal moves:

$$Time_R = \frac{Pulse_R \times 1000}{Vel_Res} \quad (mS)$$

For the definitions of $Pulse_R$ and Vel_Res see sections B1.3.8 and B1.3.5 respectively.

For a triangular move, $Time_R$ will be zero.

B1.3.13 Actual deceleration time =

This value is the actual deceleration time ($Time_D$) and is calculated as follows for trapezoidal moves:

$$Time_D = \frac{(AQ5 - AQ4) \times Z_D \times 5}{24576} \quad (mS)$$

For the definition of Z_D see section B1.3.2.

For a triangular move, $Time_D$ is multiplied by the ratio R_T (described in section B1.3.8) before being displayed.

B1.3.14 Actual total acc/dec time =

If a value was not entered for total pulses (section B1.2.1), this value is displayed as the total time spent accelerating and decelerating ($Time_{A+D}$) and is calculated as follows:

$$Time_{A+D} = Time_A + Time_D$$

For the definitions of $Time_A$ and $Time_D$ see section B1.3.11 and B1.3.13.

B1.3.15 Actual total move time =

If a value was entered for total pulses (section B1.2.1), this value is displayed as the total time required for the entire move ($Time_{TOT}$) and is calculated as follows:

$$Time_{TOT} = Time_A + Time_R + Time_D$$

For the definitions of $Time_A$, $Time_R$ and $Time_D$ see sections B1.3.11, B1.3.12 and B1.3.13 respectively.

This page was intentionally left blank.

APPENDIX C: INDEXED MOVES

This appendix details the added functionality of model number HE693STP113 Stepper Indexer Module for the Series 90-30 PLC. The user of this product should have an understanding of the standard functionality of the stepper indexer modules in addition to the information contained in this document.

C1.1 Wiring

The pinout of the HE693STP113 is identical to any of the isolated Stepper Indexer Modules, with the exception of the HOME3 input. The STP113 utilizes this input (pin 14 on the 20 pin terminal strip) as its INDEX input. The INDEX input is wired with the same electrical considerations as the HOME3 input. The INDEX + is connected at pin 14 of the terminal block while the negative connection is attached to pin 20, digital ground. See page A-3 of Appendix A for more details.

PIN	SIGNAL	UNITS	Type
1	D GND	Digital Ground	Diff
2	STEP1-	Axis 1 motor step outputs	Diff
3	STEP1+		Diff
4	STEP2-	Axis 2 motor step outputs	Diff
5	STEP2+		Diff
6	STEP3-	Axis 3 motor step outputs	Diff
7	STEP3+		Diff
8	DIR-	Motor direction outputs	Diff
9	DIR+		Diff
10	ENC B-	Phase B incremental encoder inputs	Diff
11	ENC B+		Diff
12	ENC A-	Phase A incremental encoder inputs	Diff
13	ENC A+		Diff
14	INDEX +	Indexed move input	S.E./Isol
15	HI LIM-	Upper end limit input	S.E./Isol
16	HOM 2-	Axis 2 home input	S.E./Isol
17	LO LIM-	Lower end limit input	S.E./Isol
18	HOM 1-	Axis 1 home input	S.E./Isol
19	ESTOP+	Emergency stop input	S.E./Isol
20	D GND / I GND	Digital Ground or Isolated Ground	S.E./Isol

Table C1-1. I/O wiring for the HE693STP113.

C1.2 Configuration

Due to the information required to perform an indexed move, the STP113 requires additional I/O to be allocated to the module as compared to a standard isolated module. Configuration of the STP113 is identical to configuration of a HE693STP110, with the exception of the number of %AQ registers assigned to the module. The configuration parameters for the STP113 are shown in Table C1-1 below. For further details on the configuration parameters, see pages 2-3 through 2-5 of Chapter 2.

C1.2.1 Find Home

Byte 2 of the configuration has been redefined. Previously, this byte was used to define the parity for serial communications. Since serial communication is not supported, this byte is now used to select the "Find Home" algorithm. A "0" entered for this parameter indicates the Normal (or default) algorithm. A "1" entered for this setting configures the module for the Simplified algorithm. The Simplified algorithm assumes that the home command will be run at a slow enough step rate that there is no possibility of loss of motor synchronization or overshoot.

Byte 3 has been redefined as a spare byte and is not used. This configuration byte was previously used for the serial communications baud rate.

MODEL	%I	%Q	%AI	%AQ	Byte 1	Byte 2	Byte 3
HE693STP113	16	16	4	14	1	1 or 0	0

MODEL	Byte 4	Byte 5	Byte 6	Byte 7
HE693STP113	Encoder Type	Encdr. Multiplier (01-FF)H	Encoder Divisor (01-0F)H	Encdr. Tolerance (00-FF)H

BYTE 4 VALUE	ENCODER TYPE
0	NONE
1	QUADRATURE
2	UP/DOWN
3	QUAD NO MARKER

Table C1-2. Configuration parameters of HE693STP113.

C1.3 Controlling Motion

C1.3.1 Status Bit Inputs (%I)

The status bit inputs of the STP113 are identical to those detailed in Section 3.1 on Page 3-1.

C1.3.2 Command Outputs (%Q)

The command bit outputs of the STP113 are identical to those detailed in Section 3.2 on Page 3-2 **EXCEPT** for %Q11, which is defined in the STP113 as the “index move” command. An index move command causes the stepper module to execute a special relative move. If a valid index signal (pin 14 on the terminal strip) is not received, the module executes a standard relative move. If a valid index signal is received, the stepper module moves a predetermined number of steps from that point.

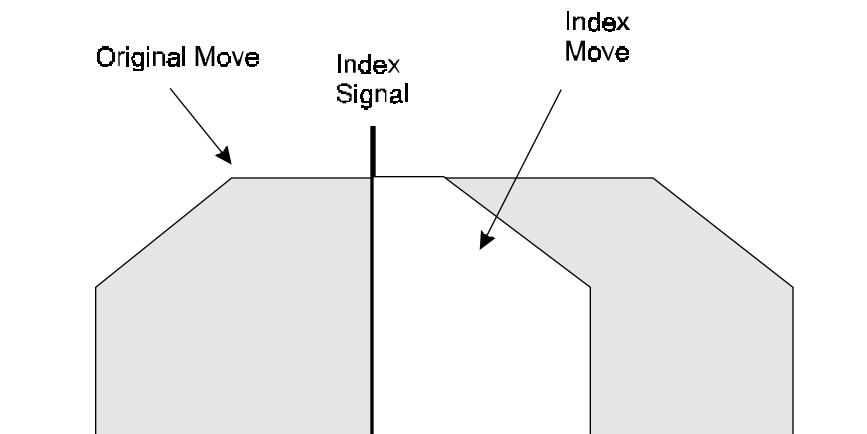

Figure C1-1. Index move

C1.3.3 Status Word Inputs (%AI)

The status word inputs of the STP113 are identical to those detailed in Section 3.3 on Page 3-3.

C1.3.4 Command Word Outputs (%AQ)

The STP113 contains several command word outputs in addition to those detailed in Section 3.4 on Page 3-4. **Table C1-3** below lists the additional %AQ command word outputs.

POINT	DESCRIPTION	MINIMUM	MAXIMUM
%AQ8	Index Destination Position (Low Word)	0	+8,388,607
%AQ9	Index Destination Position (High Word)		
%AQ10	Index Deceleration	0	27300
%AQ11	Index Window Open (Low Word)	0	+8,388,607
%AQ12	Index Window Open (High Word)		
%AQ13	Index Window Closed (Low Word)	0	+8,388,607
%AQ14	Index Window Closed (High Word)		

Table C1-3. Additional Command Word Outputs (%AQ) for STP113.

Index Destination Position. This is a double integer value which establishes the length of the index move. The index move is executed starting at the point in which a valid index input is asserted. If a valid index input is not received during the index move, the destination position defined in %AQ1 is utilized instead.

Index Deceleration. This is the deceleration time (in mS) to be used during an index move. It is only used during an index move when a valid index signal is received. If a valid index signal is not received during the index move, the deceleration time defined in %AQ7 is utilized instead.

Index Window Open. This is the starting point (in steps) in which a index signal is considered valid. An index signal received before this point is ignored. The Index Window Open point must be defined as a point which occurs after the full acceleration point.

Index Window Closed. This is the ending point (in steps) in which an index signal is considered valid. An index signal received before this point is ignored. The Index Window Closed point must be defined as a point which occurs no later than 1mS before the deceleration point.

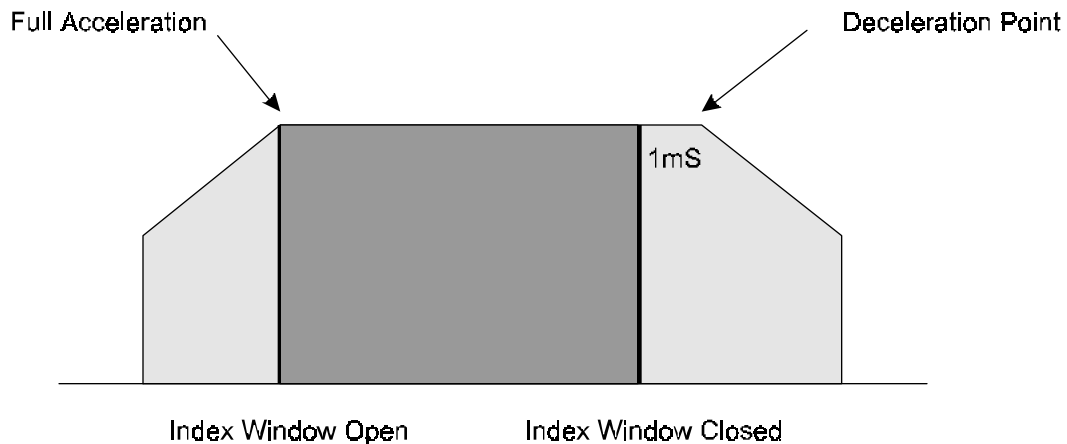

Figure C1-2. Restrictions on Index Window Open and Index Window Closed Parameters.



29 September 1999

Revision pages for

Horner APG’s Stepper Positioning Module User Manual, Sixth Edition

for Models

HE693STPxx0 Revision G or later AND

HE693STPxx1 Revision A or later AND

HE693STP104 Revision A or later

Attached to this cover page are revisions for the Stepper Positioning Module User Manual dated 12-11-97, MAN0084-06.

THESE REVISED REQUIREMENTS ARE NOW IN EFFECT.

New and revised pages may be issued periodically. For user manual updates, please contact Horner APG, Technical Support Division, at (317) 916-4274 or visit our website at www.heapg.com.

Revision Key

Changes to text, tables or graphics contained in the attached revision are indicated as follows:

1. Added text is underlined.
2. Deleted text is ~~lined through~~.
3. New, revised, or deleted items are specified as such in ().

List of Effective Pages

*The most current user manual consists of the following list of effective pages including the attached revision pages: * Denotes new or revised pages*

Page	Date
*Title Page.....	Revision Page dated 29 September 1999
*iii.....	Revision Page dated 29 September 1999
iv – v.....	Contained in MAN0084-06 dated 12-11-97
*vi.....	Revision Page dated 29 September 1999
*vii.....	Revision Page dated 29 September 1999
viii.....	Contained in MAN0084-06 dated 12-11-97
1-1	Contained in MAN0084-06 dated 12-11-97
2-1.....	Contained in MAN0084-06 dated 12-11-97
*2-2.....	Revision Page dated 29 September 1999
2-3.....	Contained in MAN0084-06 dated 12-11-97
*2-4.....	Revision Page dated 29 September 1999
3-1 – 3-8.....	Contained in MAN0084-06 dated 12-11-97
4-1 – 4-11.....	Contained in MAN0084-06 dated 12-11-97

List of Effective Pages continued on next page.

List of Effective Pages continued

5-1 – 5-5.....Contained in MAN0084-06 dated 12-11-97
A-1 – A-2.....Contained in MAN0084-06 dated 12-11-97
*** A-3 – A-4.....Revision Pages dated 29 September 1999**
B-1 – B6.....Contained in MAN0084-06 dated 12-11-97
C-1 – C-4.....Contained in MAN0084-06 dated 12-11-97

(Revised Logo)



**User Manual for the
HE693STPxx0 Revision G or later AND
HE693STPxx1 Revision A or later AND
HE693STP104 Revision A or later**

Stepper Positioning Module

**Sixth Edition
12-11-1997**

MAN0084-06

(REVISED. Reflects name change from Horner Electric, Inc. to Horner APG, LLC.)

LIMITED WARRANTY AND LIMITATION OF LIABILITY

Horner APG,LLC ("HE-APG") warrants to the original purchaser that Stepper Positioning Module manufactured by HE-APG is free from defects in material and workmanship under normal use and service. The obligation of HE-APG under this warranty shall be limited to the repair or exchange of any part or parts which may prove defective under normal use and service within two (2) years from the date of manufacture or eighteen (18) months from the date of installation by the original purchaser whichever occurs first, such defect to be disclosed to the satisfaction of HE-APG after examination by HE-APG of the allegedly defective part or parts. THIS WARRANTY IS EXPRESSLY IN LIEU OF ALL OTHER WARRANTIES EXPRESSED OR IMPLIED INCLUDING THE WARRANTIES OF MERCHANTABILITY AND FITNESS FOR USE AND OF ALL OTHER OBLIGATIONS OR LIABILITIES AND HE-APG NEITHER ASSUMES, NOR AUTHORIZES ANY OTHER PERSON TO ASSUME FOR HE-APG, ANY OTHER LIABILITY IN CONNECTION WITH THE SALE OF THIS Stepper Positioning Module. THIS WARRANTY SHALL NOT APPLY TO THIS Stepper Positioning Module OR ANY PART THEREOF WHICH HAS BEEN SUBJECT TO ACCIDENT, NEGLIGENCE, ALTERATION, ABUSE, OR MISUSE. HE-APG MAKES NO WARRANTY WHATSOEVER IN RESPECT TO ACCESSORIES OR PARTS NOT SUPPLIED BY HE-APG. THE TERM "ORIGINAL PURCHASER", AS USED IN THIS WARRANTY, SHALL BE DEEMED TO MEAN THAT PERSON FOR WHOM THE Stepper Positioning Module IS ORIGINALLY INSTALLED. THIS WARRANTY SHALL APPLY ONLY WITHIN THE BOUNDARIES OF THE CONTINENTAL UNITED STATES.

In no event, whether as a result of breach of contract, warranty, tort (including negligence) or otherwise, shall HE-APG or its suppliers be liable of any special, consequential, incidental or penal damages including, but not limited to, loss of profit or revenues, loss of use of the products or any associated equipment, damage to associated equipment, cost of capital, cost of substitute products, facilities, services or replacement power, down time costs, or claims of original purchaser's customers for such damages.

ABOUT PROGRAMMING EXAMPLES

Any example programs and program segments in this manual or provided on accompanying diskettes are included solely for illustrative purposes. Due to the many variables and requirements associated with any particular installation, Horner APG cannot assume responsibility or liability for actual use based on examples and diagrams. It is the sole responsibility of the system designer utilizing Stepper Positioning Module to appropriately design the end system, to appropriately integrate the Stepper Positioning Module and to make safety provisions for the end equipment as is usual and customary in industrial applications as defined in any codes or standards which apply.

Note: The programming examples shown in this manual are for illustrative purposes only. Proper machine operation is the sole responsibility of the system integrator.

(REVISED. Reflects name change from Horner Electric, Inc. to Horner APG, LLC.)

PREFACE

This manual explains how to use the Horner APG's Stepper Positioning Modules.

Copyright (C) 1993 Horner APG, LLC. 640 North Sherman Drive Indianapolis, Indiana 46201. All rights reserved. No part of this publication may be reproduced, transmitted, transcribed, stored in a retrieval system, or translated into any language or computer language, in any form by any means, electronic, mechanical, magnetic, optical, chemical, manual or otherwise, without the prior agreement and written permission of Horner APG, LLC.

All software described in this document or media is also copyrighted material subject to the terms and conditions of the Horner Software License Agreement.

Information in this document is subject to change without notice and does not represent a commitment on the part of Horner APG, LLC.

Series 90-30 and Logicmaster are trademarks of GE Fanuc Automation North America, Inc

Alspla 8000 and P8 are trademarks of CEGELEC.

For user manual updates, contact Horner APG, LLC., Technical Support Division, at (317) 916-4274 or visit our website at www.heapg.com.

MODULE SPECIFICATIONS

I/O Connector Specifications**(REVISED)**

PARAMETER	MIN	MAX	UNITS
+5V Power Output (Step/Direction)	-	300	mA
Step Outputs Frequency	DC	245	KHz
Step Outputs High (-20mA)	2.5	-	VDC
Step Outputs Low (+20mA)	-	0.5	VDC
Direction Output Setup Time	2	-	mS
Direction Output High (-20mA)	2.5	-	VDC
Direction Output Low (+20mA)	-	0.5	VDC
Direction Output High (-60mA, Rev A)	2.5	-	VDC
Direction Output Low (+60mA, Rev A)	-	0.5	VDC
Encoder Input Frequency	DC	1.0	MHz
Encoder Single-Ended Threshold	1.2	1.6	VDC
Encoder Differential Threshold High	-	0.2	VDC
Encoder Differential Threshold Low	-0.2	-	VDC
Home Inputs Off	12	-	VDC
Home Inputs On (+1mA)	-	9	VDC
End Limits Inputs Off (all models except STP104)	12	-	VDC
End Limits Inputs On (+1mA) (all models except STP104)	-	9	VDC
End Limits Inputs Off (+1mA) (covers STP104 only)	-	9	VDC
End Limits Inputs On (covers STP104 only)	12	-	VDC
Emergency Stop Input On	12	-	VDC
Emergency Stop Input Off (+1mA)	-	9	VDC

(Figure revised 29 SEP 1999.)

(REVISED)

PIN	SIGNAL	UNITS	TYPE
1	D GND	Digital Ground	Diff
2	STEP1-	Axis 1 motor step outputs	Diff
3	STEP1+		Diff
4	STEP2-	Axis 2 motor step outputs	Diff
5	STEP2+		Diff
6	STEP3-	Axis 3 motor step outputs	Diff
7	STEP3+		Diff
8	DIR-	Motor direction outputs	Diff
9	DIR+		Diff
10	ENC B-	Phase B incremental Encoder inputs	Diff
11	ENC B+		Diff
12	ENC A-	Phase A incremental Encoder inputs	Diff
13	ENC A+		Diff
14	HOM3-	Axis 3 home input	S.E./Isol
15	<u>HI LIM</u> HI LIM + (STP104 only) HI LIM - (All models except STP104)	<u>Upper end limit input</u> <u>Upper end limit input</u>	S.E./Isol
16	HOM 2-	Axis 2 home input	S.E./Isol
17	<u>LO LIM</u> LO LIM + (STP104 only) LO LIM - (All models except STP104)	<u>Lower end limit input</u> <u>Lower end limit input</u>	S.E./Isol
18	HOM 1-	Axis 1 home input	S.E./Isol
19	ESTOP+	Emergency stop input	S.E./Isol
20	D GND / I GND	Digital Ground or Isolated Ground	S.E./Isol

Figure 2-1 Stepper Positioning Module Terminal Strip Pin-out.
(Type: Diff=Differential, S.E./Isol.-Single Ended or Isolated)

(Figure 2.1 revised 29 SEP 1999.)

(REVISED)

MODEL	%I	%Q	%AI	%AQ	BYTE 1	BYTE 2	BYTE3
HE693STP100	16	16	2	6	1	0	0
HE693STP101				7			
HE693STP110			4	6			
HE693STP111				7			
HE693STP300			2	6			
HE693STP301				7			
HE693STP310			4	6			
HE693STP311				7			
HE693STP104			2	7			

Figure 2-4 I/O Reference and Bytes 1-3 Configuration Parameters

(Figure 2-4 revised 29 SEP 1999.)

The second column of configuration parameters contains a number of additional configuration bytes. The stepper module requires that Byte 1 through Byte 7 be configured. For these parameters, see the chart for Bytes 1-3, and the chart below for Bytes 4-7.

(REVISED)

MODEL	BYTE 4	BYTE 5	BYTE 6	BYTE 7
HE693STP100	0	0	0	0
HE693STP101	Encoder Type	Encdr. Multiplier (01-FF)H	Encoder Divisor (01-0F)H	Encdr. Tolerance (00-FF)H
HE693STP110				
HE693STP111				
HE693STP300	0	0	0	0
HE693STP301	Encoder Type	Encoder Multiplier	Encoder Divisor	Encdr. Tolerance
HE693STP310				
HE693STP311				
HE693STP104	0	0	0	0

Figure 2-5 Bytes 4-7 Configuration Parameters

(Figure 2-5 revised 29 SEP 1999.)

Bytes 4-7 are utilized by those indexer models, which feature encoder feedback capability. Byte 4 configures the type of encoder used (see Figure 2-6), Byte 5 and 6 set the encoder multiplier and divisor, and Byte 7 sets the encoder tolerance. For details on encoder feedback operation, see Chapter 5.

(REVISED)

The Stepper Indexer Module allows real world switches (limit, proximity, mechanical, etc.) to be connected to the module. This enhances the ability of the overall stepper control system to find home position accurately and to quickly stop motion in the event of an emergency situation.

The Stepper Models HE693STPxx0 allow mechanical switches, proximity switches, limit switches, etc. to be connected to the module. Optical isolation is *not* provided, thus the common for these switch inputs (terminal 20 on the terminal strip) is designated "digital ground", electrically equivalent to the common for the step and direction outputs of the module. For these non isolated models, switches must be selected which are compatible with 5V signal levels, and great care must be taken to ensure that noise is not picked up by the wiring run from these switches to the module terminal strip. Preventative steps may include separate conduit, and/or shielded wiring. If the switches selected require power, this must be provided externally.

The Stepper Indexer models HE693STPxx1 [and HE693STP104](#) provide optical isolation for the switch inputs. Optical isolation is provided, thus the common for the switch inputs is designated "isolated ground", isolated from the common for the step and direction outputs. Switches may be selected which are compatible with 12 or 24V signal levels. If proximity type switches are used, they must be of the NPN type. The voltage required to power the switches (if needed) must be provided externally.

(Paragraph revised 29 SEP 1999.)

Home, End Limit, and Emergency Stop Inputs

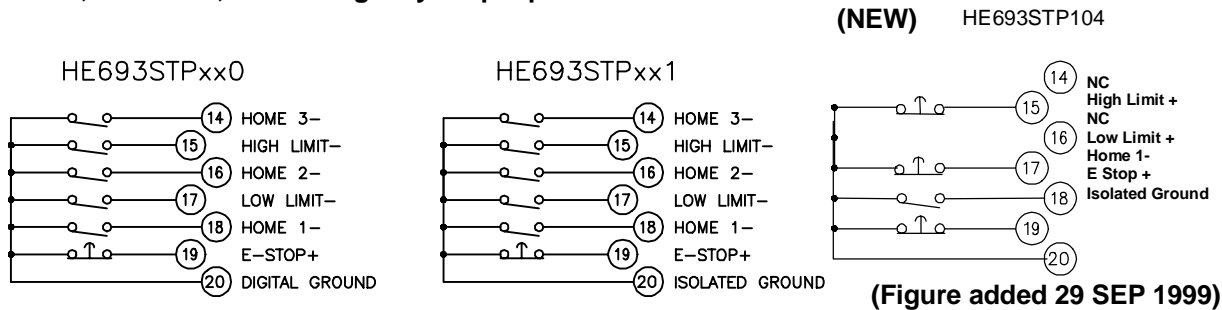

(Figure added 29 SEP 1999)

(REVISED)

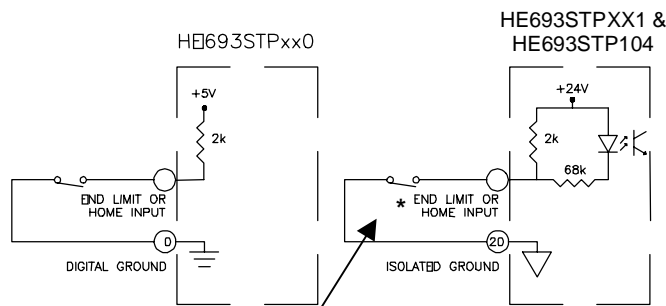

* The end limit inputs on an HE693STP104 are active high for compatibility with normally closed switches.

(Added note to Figure 29 SEP 1999)

(REVISED)

Electrical Connection for Mechanical Switches

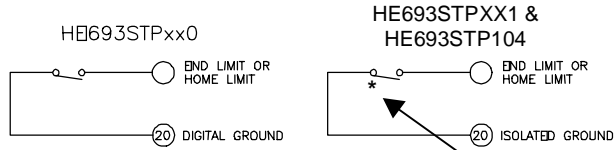

Electrical Connection for Proximity Switches

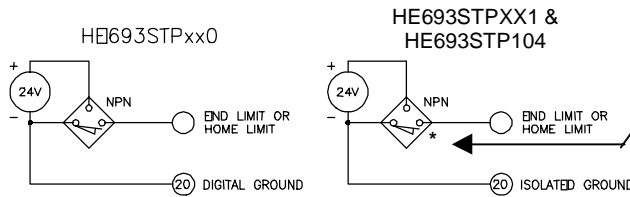

* The end limit inputs on an HE693STP104 are active high for compatibility with normally closed switches.

(Added note to figures 29 SEP 1999.)