

### 1 DESCRIPTION

The Analog Current Output Module (HE693DAC420) provides four analog output channels, with 14-bits of resolution, and 1500VAC (RMS) isolation channel-to-channel and channel-to-ground. The module converts digital values (0 to +32,000) residing in %AQ registers to analog current signals. The %AQ values are set by the ladder logic program in the PLC CPU. Each channel may be set to "default to 4/0mA" or "hold last state" when the PLC is taken out of RUN mode. The output mode of each channel may be set to 4-20mA or 0-20mA. These channel characteristics are set with configuration parameters in the configuration software or Hand-Held Programmer. A loop power supply (24VDC) must be supplied by the user.

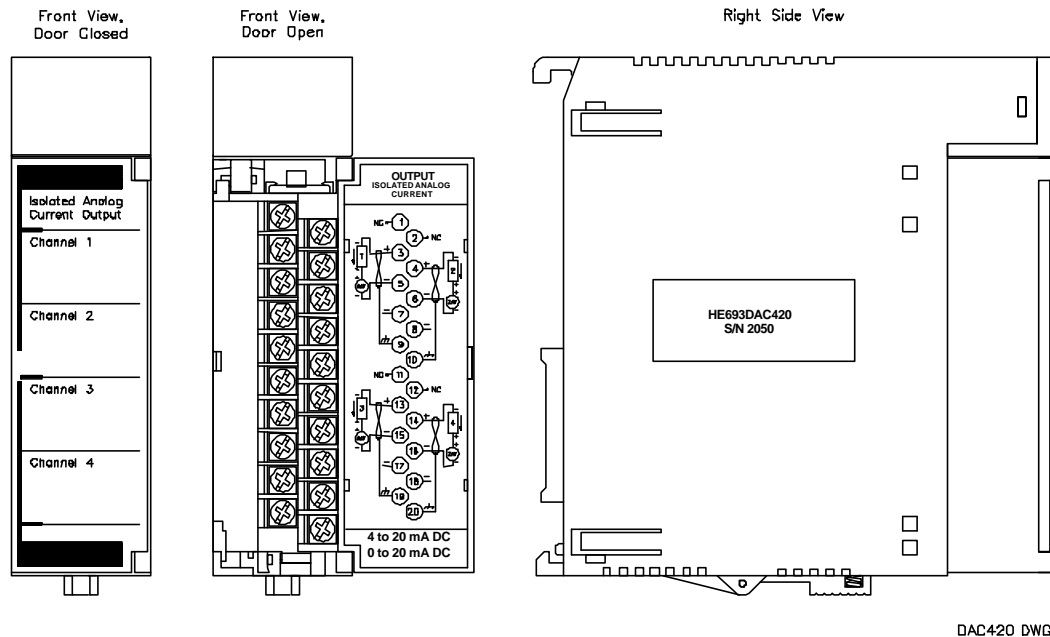

Figure 1 – HE693DAC420 Module

### 2 SPECIFICATIONS

Table 1 - HE693DAC420 Specifications			
Power Consumption, max	90mA @ 5VDC 120mA @ 24VDC	Resolution (4-20mA mode)	2.0uA
		Resolution (+/-20mA mode)	2.5uA
Current Surge on Power-up	250mA for 10ms. @ 5VDC 900mA for 30ms. @ 24VDC	User Supplied Loop Voltage	3 - 32VDC
Number of Channels	4	Load Impedance	≤ 1.1kohms @ 24V loop voltage
I/O Required	4 %AQ	Common Mode Isolation	1500VAC (RMS), +/- 2000VDC
Output Range	4-20mA or 0-20mA	Channel to Channel	1500VAC (RMS), +/- 2000VDC
D/A Resolution	13 bits plus sign	Operating Temperature	0 to 60°C
Maximum Linearity Error	0.10% full scale (4 to 20mA range)	Relative Humidity	5% to 95%, non-condensing
	0.15% full scale (0 to 20mA range)		

### 3 CONFIGURATION

		SOFTWARE CONFIGURATION				FOREIGN MODULE			
SLOT 2	Catalog #:	FOREIGN							
	FRGN								
		Module ID :	3			Byte 9 :	00		
		%I Ref Adr :	%I0001	Byte 1 :	00000001	Byte 10 :	00		
		%I Size :	0	Byte 2 :	00000000	Byte 11 :	00		
		%Q Ref Adr :	%Q0001	Byte 3 :	00	Byte 12 :	00		
		%Q Size :	0	Byte 4 :	00	Byte 13 :	00		
		%AI Ref Adr :	%AI001	Byte 5 :	00	Byte 14 :	00		
		%AI Size :	0	Byte 6 :	00	Byte 15 :	00		
		%AQ Ref Adr :	%AQ001	Byte 7 :	00	Byte 16 :	00		
		%AQ Size :	4	Byte 8 :	00				

Figure 2 - LM90 Foreign Module Configuration.

To reach this screen in the LM90 Configuration Package, select I/O Configuration (F1), cursor over to the slot containing the module and select Other (F8), and Foreign (F3).

%AQ Size	Byte 1	Bytes 2-5	Bytes 6-9
4	0001	00: Default to 4/0mA	00: 4-20mA Mode
		01: Hold Last State	01: 0-20mA Mode

Bytes 2-5 set the “Hold Last State” parameter and Bytes 6-9 set the output mode for each channel.

### 4 SCALING

Mode	Scaling	Smallest Step Change
4-20mA	$\%AQ = (mA-4) / 16 \times 32,000$	4 (dec) = 2.0uA
0-20mA	$\%AQ = mA / 20 \times 32,000$	4 (dec) = 2.5uA

The two least significant bits of each %AQ do not affect the output current, therefore the smallest decimal step change is 4, which corresponds to 2.0uA (4-20mA mode) or 2.5uA (0-20mA mode).

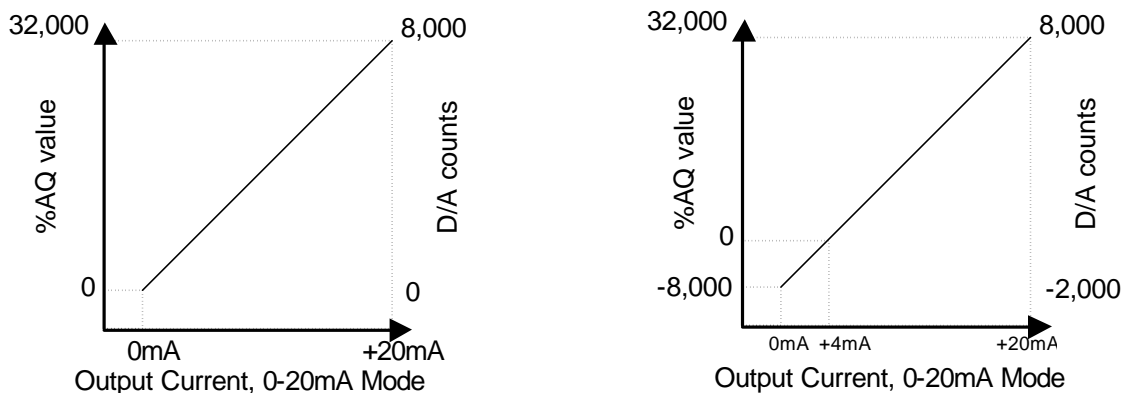

Figure 3 - Output Current vs. %AQ Value and Output Current vs. D/A Counts for both 4-20mA mode and 0-20mA mode

## 5 WIRING

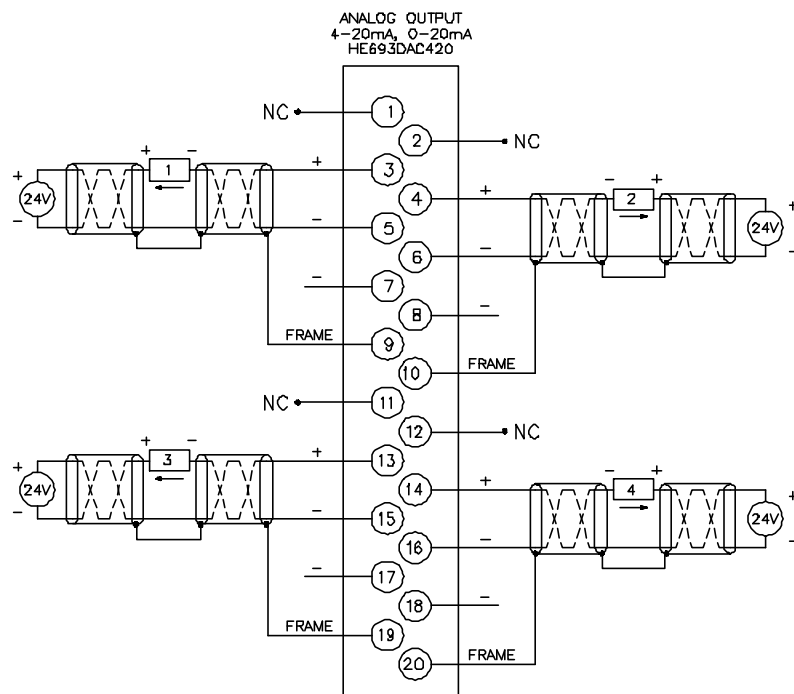

Figure 4 - Wiring

## 6 INSTALLATION / SAFETY

**Warning: Upon power-up, the DAC420 outputs 4mA.**

The following Safety Precautions need to be followed.

Wiring needs to be routed in its own conduit.

Shielded, twisted pair extension wiring offers best noise immunity.

If shielded wiring is used, a good earth ground connection, at one end only, is critical. If shields are connected at the module end, terminals 9, 10, 19 and 20 are used as the shield ground point.

Adhere to the following safety precautions whenever any type of connection is made to the module.

Connect the green safety (earth) ground first before making any other connections.

When connecting to electric circuits or pulse-initiating equipment, open their related breakers. Do not make connections to live power lines.

Make connections to the module first; then connect to the circuit to be monitored.

Route power wires in a safe manner in accordance with good practice and local codes.

Wear proper personal protective equipment including safety glasses and insulated gloves when making connections to power circuits.

Ensure hands, shoes, and floor are dry before making any connection to a power line.

Make sure the unit is turned OFF before making connection to terminals. Make sure all circuits are de-energized before making connections.

Before each use, inspect all cables for breaks or cracks in the insulation. Replace immediately if defective.

## 7 TECHNICAL ASSISTANCE

For assistance and technical manual updates, contact Technical Support at the following locations:

**North America:**

(317) 916-4274

[www.heapg.com](http://www.heapg.com)

email: [techspt@heapg.com](mailto:techspt@heapg.com)

**Europe:**

(+) 353-21-4321-266

[www.horner-apg.com](http://www.horner-apg.com)