

CANopen Interface for the GE Fanuc Series 90™-30 PLC

Product Specifications and Installation Data

DESCRIPTION

The Horner Electric CANopen Interface Module (HE693CAL101) allows Cegelec and Lenze drives to be directly connected to the GE Fanuc Series 90™-30 PLC. These drives feature built-in CAN communications, supporting the industry standard CANopen protocol. Performance of the CANopen interface is far superior to serial protocols typically supported by other drives. It is also cost effective, as the CAN interface is designed into the drives without the requirement of a communications option board. The CANopen module (CAL101) resides in any slot of the Series 90-30 PLC. Any of the Series 90-30 PLCs, from the CPU311 on up, are supported by the module. Up to eight drives, addressed 1-8, can communicate with the PLC module, addressed at 32. The module is pre-configured, so no network configuration is necessary.

WIRING

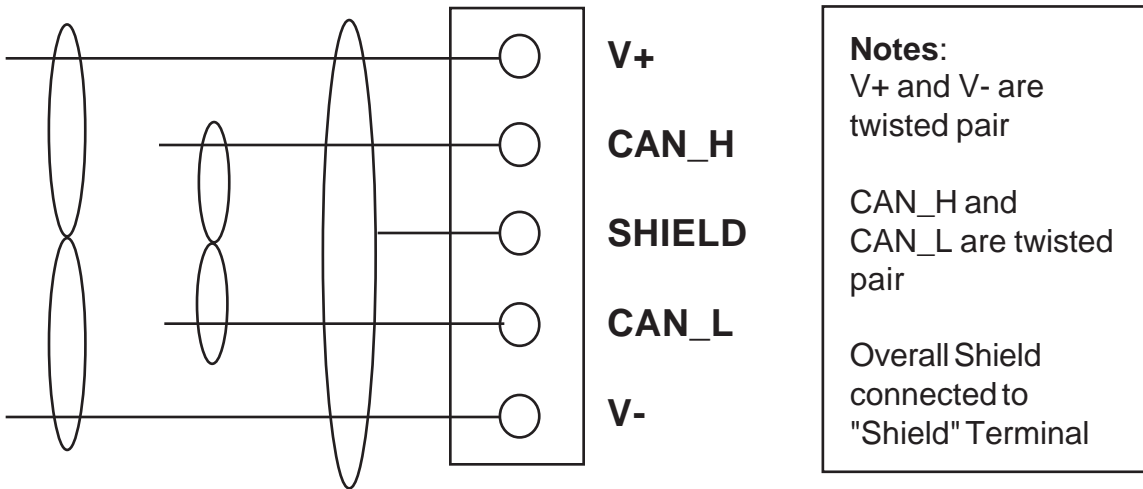

SPECIFICATIONS

Specification	Part Number	Specification	Part Number
PLC Power Consumption	175mA @ 5Vdc	Drives Supported	8
Network Voltage	11 to 25Vdc	PLC Data Registers Required	32 %AI and 32 %AQ
Operating Temperature	0 to 60°C	Relative Humidity	5 to 95%, non-condensing

SOFTWARE CONFIGURATION	
SLOT 2	Catalog #: FOREIGN FOREIGN MODULE
FRGN	
Module ID :	
%I Ref Adr : %I0001	Byte 1 : 00000001
%I Size : 0	Byte 2 : 00100000
%Q Ref Adr : %Q0001	Byte 3 : 02
%Q Size : 0	Byte 4 : 01
%AI Ref Adr : %AI001	Byte 5 : 00
%AI Size : 32	Byte 6 : 00
%AQ Ref Adr : %AQ001	Byte 7 : 00
%AQ Size : 32	Byte 8 : 00
	Byte 9 : 00
	Byte 10 : 00
	Byte 11 : 00
	Byte 12 : 00
	Byte 13 : 00
	Byte 14 : 00
	Byte 15 : 00
	Byte 16 : 00

Foreign Module Configuration. To reach this screen, select I/O Configuration (F1), cursor over to the slot containing the module and select Other (F8), and Foreign (F3). The sample configuration above shows the proper configuration for a CANopen module (CAL101) set for address 32 (Byte 2 = 0010000); baud rate 500KHz (Byte 3 = 02H), and Synchronization Jump Width of 1 (Byte 3 = 01H).

Byte 1	Byte 2	Byte 3	Byte 4
Smart Module ID Bit	CAN ID	CAN Baud Rate	Synchronization Jump Width (SJW)
Always 00000001	0-32, binary	0 = 125KHz	1-4
		1 = 250KHz	
		2 = 500KHz	
		3 = 1MHz	

Configuration Parameters. Byte 1 is always 1, Byte 2 is the node address, Byte 3 is the baud rate, and Byte 4 is the Synchronization Jump Width. The legal values for these configuration parameters are shown in the table above.

Data from Drive to PLC

Data from PLC to Drive

Drive Number	Node Address (TID)	PLC Data Location	PLC Data Location	Drive Number	Drive Node Address (RID)
1	1	%AI 001-004	%AQ 001-004	1	1
2	2	%AI 005-008	%AQ 005-008	2	2
3	3	%AI 009-012	%AQ 009-012	3	3
4	4	%AI 013-016	%AQ 013-016	4	4
5	5	%AI 017-020	%AQ 017-020	5	5
6	6	%AI 021-024	%AQ 021-024	6	6
7	7	%AI 025-028	%AQ 025-028	7	7
8	8	%AI 029-032	%AQ 029-032	8	8

Data Transfer. Four words of data is read and written between the PLC and each drive. The PLC is pre-configured to communicate with up to eight drives. Data produced by the drives show up in %AI (analog input) registers in the PLC. Data consumed by the drives are set in %AQ registers in the PLC. The two tables above show the data transferred from the Drive to the PLC (at left) and the data transferred from the PLC to the drive (at right).