

6241BP10822

New In Stock!

ABB

<http://www.pdfsupply.com/automation/abb/623-624-series/6241BP10822>

623-624-series

1-919-535-3180

Electronic Assembly for 6241BP10812

www.pdfsupply.com

Email: sales@pdfsupply.com

Specifications

Block Type: Catalog Numbers: 32 Circuit 12/24 VDC Source: I/O Block Terminal Assembly Electronics Assembly 32 Circuit 5/12/24 VDC TTL Sink: I/O Block Terminal Assembly Electronics Assembly	DC 32-circuit discrete input and output IC660BBD024 IC660TBD024 IC660EBD024 IC660BBD025 IC660TBD025 IC660EBD025																														
Size (height x width x depth): Weight LEDs (I/O Block) LEDs (each circuit) Block to Block Isolation Heat Dissipation	8.83" (22.44cm) x 3.56" (9.05cm) x 4.42" (11.23cm) 4 lbs. (1.8 kg) Unit OK, I/O Enabled Individual logic side indicators 850V 11W minimum with 8 inputs 18W maximum with 32 outputs at .5 amp																														
Operating voltage (single source) Ripple (maximum) Required DC power Power supply dropout times	10 to 30 VDC (12/24 V supply) 4.9 to 5.3 VDC (5 V supply) (sink model only) absolute instantaneous limit 10% (12/24 volts), 1% (5 volts) 150 mA typical, 300 mA maximum 4 mS at 12 volts, 20 ms at 24 volts																														
Input Characteristics: Input voltage relative to (DC-) Input ON, 5 VDC supply 12 VDC supply 24 VDC supply Input OFF 5 VDC supply 12 VDC supply 24 VDC supply Input impedance (typical) Input processing time (typical) Selectable input filter times	<table border="0"> <thead> <tr> <th></th> <th><u>Source Blocks</u></th> <th><u>Sink Blocks</u></th> </tr> </thead> <tbody> <tr> <td></td> <td>not applicable</td> <td>0-0.8 VDC</td> </tr> <tr> <td></td> <td>8-12 VDC</td> <td>0-4 VDC</td> </tr> <tr> <td></td> <td>18-24 VDC</td> <td>0-6 VDC</td> </tr> <tr> <td></td> <td>not applicable</td> <td>2-5 VDC</td> </tr> <tr> <td></td> <td>0-6 VDC</td> <td>6-12 VDC</td> </tr> <tr> <td></td> <td>0-12 VDC</td> <td>12-24 VDC</td> </tr> <tr> <td></td> <td>3.3 K ohms</td> <td></td> </tr> <tr> <td></td> <td>1.4 mS (plus selectable filter delay)</td> <td></td> </tr> <tr> <td></td> <td>1, 2, 3, 4, 5, 10, 20, 30, 40, 50, 60, 70, 80, 90, or 100mS</td> <td></td> </tr> </tbody> </table>		<u>Source Blocks</u>	<u>Sink Blocks</u>		not applicable	0-0.8 VDC		8-12 VDC	0-4 VDC		18-24 VDC	0-6 VDC		not applicable	2-5 VDC		0-6 VDC	6-12 VDC		0-12 VDC	12-24 VDC		3.3 K ohms			1.4 mS (plus selectable filter delay)			1, 2, 3, 4, 5, 10, 20, 30, 40, 50, 60, 70, 80, 90, or 100mS	
	<u>Source Blocks</u>	<u>Sink Blocks</u>																													
	not applicable	0-0.8 VDC																													
	8-12 VDC	0-4 VDC																													
	18-24 VDC	0-6 VDC																													
	not applicable	2-5 VDC																													
	0-6 VDC	6-12 VDC																													
	0-12 VDC	12-24 VDC																													
	3.3 K ohms																														
	1.4 mS (plus selectable filter delay)																														
	1, 2, 3, 4, 5, 10, 20, 30, 40, 50, 60, 70, 80, 90, or 100mS																														
Output Characteristics: Maximum output current (steady state) Maximum inrush current Block output current (total) Output OFF leakage current (maximum) Output turn-on delay (maximum) Output voltage drop Output Diagnostics	0.5 amps per circuit 4 amps up to 10 mS (once every .5 sec. maximum) 16 amps 10µA 0.5 mS 2.0 volts maximum at 4 amps inrush Switch Fault																														
Environmental: Operating temperature Storage temperature Humidity Vibration	0 C to +60 C (+32 to +140 F) -40 to +100 C (-40 to +212 F) 5% to 95% (non-condensing) 5-10Hz 0.2" (5.08mm) displacement, 10-200Hz at 1G																														

Block Operation

The block has 32 identical I/O circuits, each of which can be configured as an input or an output. If the block is configured as a combination block, output feedback is provided in the corresponding input references.

32 Circuit DC Source I/O Block

A 32 Circuit DC Source I/O Block has all output devices connected to the negative (-) side of the power supply. Inputs control the positive (+) side of the power supply. For outputs, an ON condition is logic 1 and an OFF condition is a logic 0.

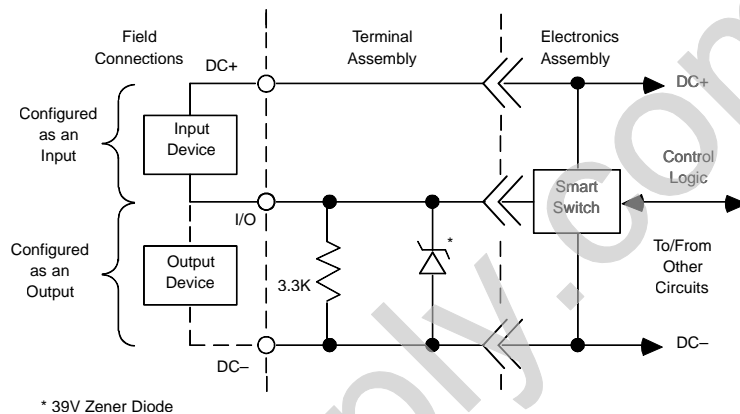

32 Circuit DC Sink I/O Block

A 32 Circuit DC Sink I/O Block has all output devices externally connected to the positive (+) side of the power supply. Inputs control the negative (-) side of the power supply. For outputs, an ON condition is logic 0 and an OFF condition is a logic 1. When outputs in a sink-type block are connected to inputs in a sink type block, a logic 1 command to the output will turn the output ON and produce a logic 1 to the PLC.

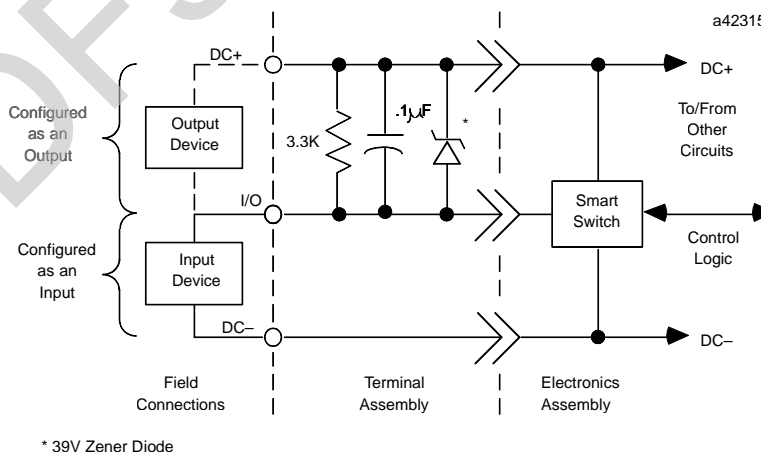

Circuit LEDs

Each circuit has its own LED. If the circuit is configured as an input, the LED indicates the presence of threshold voltage at the input terminal. If the circuit is configured as an output, the LED indicates the actual state of the load.

Inputs and Outputs

The block can be configured as an inputs-only, outputs-only, or combination block. Regardless, the block always sends 4 bytes of data each bus scan, and accepts 4 bytes of data each bus scan.

If the block is configured as an inputs-only block, all circuits must be inputs. The block will use 32 input references and NO output references.

If the block is configured as an outputs-only block, all circuits must be regular outputs; no feedback analysis can be performed. The block will use 32 output references and NO input references.

If the block is configured as a combination block, it can have any mix of input and/or output circuits. The block will use 32 input references and 32 output references. The actual state of each output circuit will be returned to the CPU in the corresponding input reference location. The CPU can monitor the feedback state to verify (after an appropriate delay) that the output switching device has operated properly and that the load has the proper voltage and current applied.

Appendix B shows reference usage for a Series 90, Series Six, or Series Five PLC.

Input Data Format

A 32 Circuit DC I/O Block broadcasts 4 bytes of input data each bus scan.

Byte #	Description
0	Inputs 1 – 8 (input 1 in bit 0)
1	Inputs 9 – 16 (input 9 in bit 0)
2	Inputs 17 – 24 (input 17 in bit 0)
3	Inputs 25 – 32 (input 25 in bit 0)

Output Data Format

The block receives 4 bytes of output data from the bus controller each bus scan.

Byte #	Description
0	Outputs 1 – 8 (output 1 in bit 0)
1	Outputs 9 – 16 (output 9 in bit 0)
2	Outputs 17 – 24 (output 17 in bit 0)
3	Outputs 25 – 32 (output 25 in bit 0)

Hand-held Monitor I/O Display

The Hand-held Monitor displays the current states of 16 circuits at a time on line 4 of the Monitor Block screen. Press a function key to see the next 16 circuits.

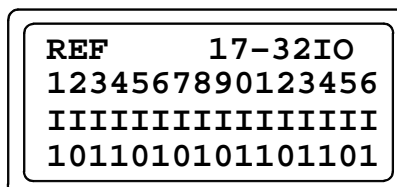

Diagnostics

The block monitors outputs for overload conditions, and checks the actual state of each output switch against its commanded state. The block reports all faults to the Hand-held Monitor. Individual circuits can be configured not to report faults to the CPU.

Short Circuit diagnostic

If the output is commanded to go on and current exceeds 5 amps for 1mS, the block automatically turns the circuit off and sends a FAILED SWITCH message. The circuit must be reset by cycling power to the block, or by sending a Clear Faults command from the Hand-held Monitor or the CPU.

Surge Current Protection

These blocks handle steady-state loads of 0.5 amps during normal operation. They will safely switch loads between 0.5 amps and 4 amps, as shown below. To protect the block, surge currents should not exceed these levels. For example, a surge current of 4 amps should not be more than 10mS in duration. A surge current of 1 amp should not exceed 30mS.

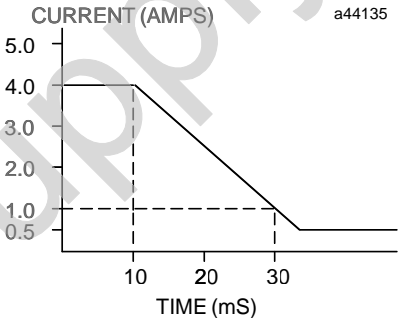

Caution

Failure to operate a circuit within these limits may result in thermal overload and damage to the block. The electronic protection will not turn the load off until the current reaches 5 amps.

Overcurrent Protection

If an output is commanded to go on and the load exceeds 5 amps for 1mS, the block automatically turns off the circuit, and sends the FAILED SWITCH message. The circuit must be reset by cycling power to the block, or by sending a Clear Faults command to the block.

Field Wiring

Field devices are wired to terminals 5–32, which accept two #14 solid wires, or two #16 stranded wires. Do not overtorque the terminal screws.

Sink Block

Any circuit can be an input or output. Connect one terminal of a field device to DC power and the other to the block (terminals 10–41). All I/O devices must return to the same power circuit. Connect outputs to the positive side of the power supply and inputs to the negative side.

For block power, connect a DC source to the DC+ terminals (6–9) and the return to the DC- terminals (42–46). Depending on layout and current loads, positive and negative connections can be bussed and made by single wires to the block or power source.

Caution

Do not apply more than 5.25 volts to the +5V terminal. Damage to the block might result.

For 5 volt Sink applications only, jumper the +5V terminal to any DC+ terminal.

Caution

For 12 or 24 volt sink applications, do not jumper the +5V terminal to DC+. It will damage the block. Leave the +5V terminal open.

DC Sink Block, Power Disconnects

Since block power is the same as circuit power, it is important to wire block power disconnects so that block power and input power will be removed at the same time.

Caution

If circuit power is not removed at the same time as block power, the block may power up when multiple inputs are activated, even though one leg of power has been removed from the block.

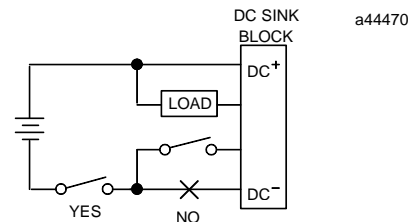
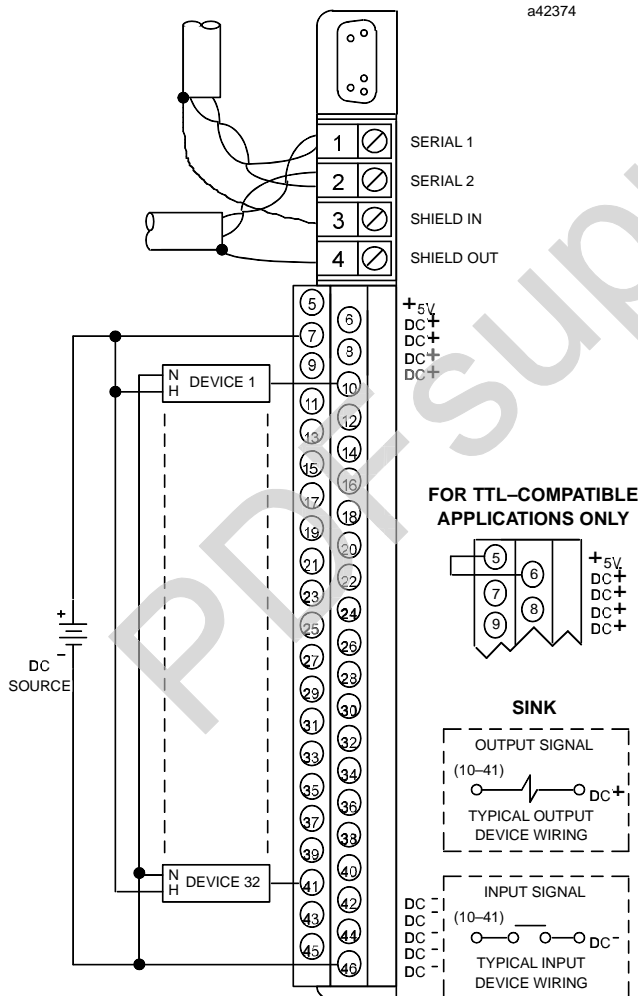

Field Wiring: Source Block

For a Source block, connect outputs to the negative side of the power supply and inputs to the positive side.

a43020

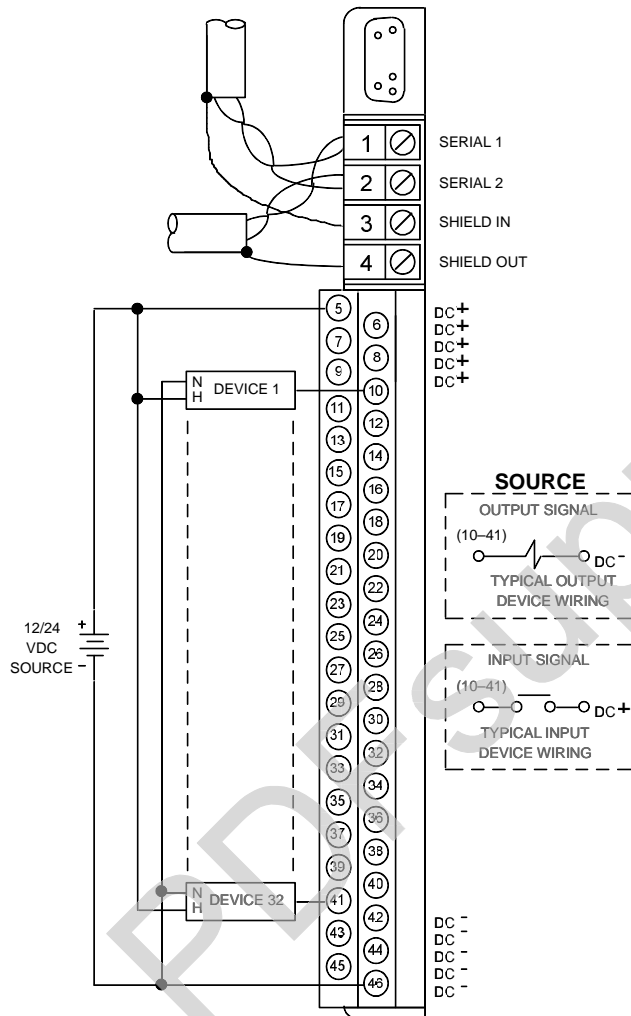

Block Power Disconnects

Since block power is the same as circuit power, it is important to wire block power disconnects so that block power and input power will be removed *at the same time*.

a44472

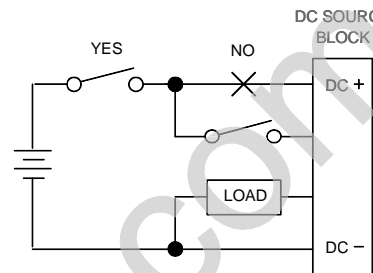

Caution

If circuit power is not removed at the same time as block power, the block may power up when multiple inputs are activated, even though one leg of power has been removed from the block.

Wiring for a Bus Switching Module

If the block will be used as a BSM Controller, connect the Bus Switching Module like a load to circuit 1. Connect either of the BSM's pigtail wires to terminal 10. For a DC Sink block, connect the other BSM wire to DC+. For a DC Source block, connect the other BSM wire to DC-.

Block Configuration

The configurable features of a 32 Circuit DC Input/Output Block are listed below. For many, the factory setting may not need to be changed.

Feature	Circuit or Block	Factory Setting	Selections
Device Number*	Block	null	0 to 31 (a number must be selected)
Reference Address*	Block	none	Depends on host CPU type
BlockI/OType*	Block	input	input, output, combination
Baud Rate*	Block	153.6std	153.6 std, 153.6 ext, 76.8, 38.4 Kbd
Pulse Test for Outputs	Block	enabled	enabled, disabled
Input Filter Time	Block	20mSec	1, 2, 3, 4, 5, 10 to 100mSec in 10mS steps
BlockI/OType	Block	input	input, output, combination
CircuitI/OType	Circuit	input	input, output
Report Faults	Circuit	yes	yes, no
Hold Last State	Circuit	no	yes, no
Output Default State	Circuit	off	on, off
BSM Present	Block	no	yes, no
BSM Controller	Block	no	yes, no
Output Default Time	Block	3 bus scans	(for bus redundancy) 2.5 or 10 sec
CPU Redundancy	Block	none	none, hot standby, duplex, GMR
Duplex Default	Block	off	on, off
Configuration Protection	Block	disabled	enabled, disabled

Features marked with an asterisk in the table are configured from the Program Block ID screen of the Hand-held Monitor, as explained in chapter 3.

The rest of the features can be configured either using a Hand-held Monitor, or by sending a Write Configuration datagram to the block from the host.

Before configuration begins, the features of each 32 Circuit DC Input/Output block should be decided upon, then recorded on a copy of the Configuration Worksheet printed on the next page.

32 Circuit DC I/O Blocks Configuration Worksheet

Block _____ Location _____

Block Features:

Configuration Protected (Y/N) _____

Block Number (0-31) _____ Block Type (Input/Output/Combination) _____

Reference Address _____ through _____

Baud Rate (153.6 Kb Std/153.6 Kb Ext/76.8 Kb/38.4 Kb)

Pulse Test (Enabled/Disabled) _____ Input Filter Time (1-100) mS _____

Redundancy Features:

Redundancy Mode (None/Standby/Duplex, GMR) _____ Duplex Default (on/off) _____

BSM Present (Y/N) _____ BSM Controller (Y/N) _____ Outputs Default (2.5/10 sec) _____

Circuit Features:

Ckt #	Reference Address	I/O Type (I/O)	Report Faults (yes/no)	(output) Hold Last State (yes/no)	(output) Default State (ON/OFF)
1	_____	_____	_____	_____	_____
2	_____	_____	_____	_____	_____
3	_____	_____	_____	_____	_____
4	_____	_____	_____	_____	_____
5	_____	_____	_____	_____	_____
6	_____	_____	_____	_____	_____
7	_____	_____	_____	_____	_____
8	_____	_____	_____	_____	_____
9	_____	_____	_____	_____	_____
10	_____	_____	_____	_____	_____
11	_____	_____	_____	_____	_____
12	_____	_____	_____	_____	_____
13	_____	_____	_____	_____	_____
14	_____	_____	_____	_____	_____
15	_____	_____	_____	_____	_____
16	_____	_____	_____	_____	_____
17	_____	_____	_____	_____	_____
18	_____	_____	_____	_____	_____
19	_____	_____	_____	_____	_____
20	_____	_____	_____	_____	_____
21	_____	_____	_____	_____	_____
22	_____	_____	_____	_____	_____
23	_____	_____	_____	_____	_____
24	_____	_____	_____	_____	_____
25	_____	_____	_____	_____	_____
26	_____	_____	_____	_____	_____
27	_____	_____	_____	_____	_____
28	_____	_____	_____	_____	_____
29	_____	_____	_____	_____	_____
30	_____	_____	_____	_____	_____
31	_____	_____	_____	_____	_____
32	_____	_____	_____	_____	_____

Pulse Test

Pulse Testing verifies the ability of a block's outputs to change state. A new block is configured to enable Pulse Testing. Pulse Testing should remain enabled if the block has loads that hold one state for long periods of time, *unless any load(s) are sensitive to pulses or interruptions*. It should be disabled if the block's loads will normally change state as the program executes. These will report faults during normal operation, and do not need to be pulsed.

Hand-held Monitor Configuration Steps

```
PULSE TEST
REF
ENABLED
  tgl entr nxt
```

1. To change the current selection, press F2 (tgl). Press F3 (enter).
2. Press F4 (next) to advance to the next configuration display.

Pulse Testing Outputs

If Pulse Testing is enabled, the block will pulse its outputs on command from either a Hand-held Monitor or the CPU. Pulse Testing checks the continuity of an output circuit including the switch device, power source, wiring, interposing devices (fuses, circuit breakers, terminals), and output device. It can be commanded from the Hand-held Monitor or the CPU. It works whether or not there is minimum current to check for a No-Load condition. Pulse Testing will not activate mechanical devices such as motor starters, relays, or solenoid valves.

Pulse Testing will momentarily cause outputs that are OFF to turn ON for 1mS and outputs that are ON to go OFF for 1mS. Failure of the Pulse Test causes the following message:

Failed Switch: If the output does not change state when pulsed for up to 1mS, or if current exceeds 5 amps for 1mS.

Input Filter Time

A filter time can be selected for inputs on the block. (The same filter will apply to all inputs). The default filter time is 20mS.

The block continuously samples an input for the length of the filter time period. If the input remains either on or off for the length of the Filter Time, the block recognizes its state. For example:

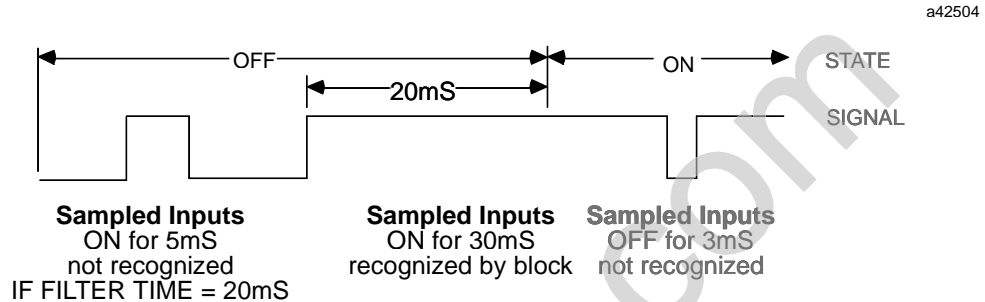

An input filter helps reject spurious noise spikes and multiple inputs generated by the bounce of mechanical devices. In controlled, noise-free environments, signals generated by clean, solid state electronics may be unnecessarily slowed by a filter, delaying system response. In such an environment, no additional filter time is needed.

In noisy environments, select a longer filter time to prevent noise from possibly causing erratic or unsafe system operations. The filter time can be 1, 2, 3, 4, 5, 10, 20, 30, 40, 50, 60, 70, 80, 90, or 100mS.

Hand-held Monitor Configuration Steps

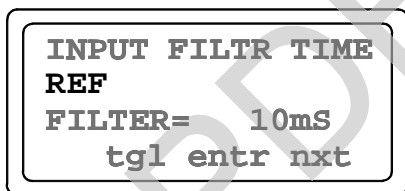

1. The screen displays the currently-selected filter time. If this time should be changed, press F2 (tgl) to display the other filter times.
2. To save a new selection, press F3 (entr).
3. Press F4 (next) to advance to the next configuration display.

I/O Circuit Type

An earlier configuration step selected the Block I/O type (on the Program Block ID screen). That step determined whether the block would be assigned all input references, all output references, or both. On the screen shown below, the I/O type of each circuit can be specified.

The default Block I/O Type and I/O Circuit Type is Input. When the Block I/O Type is Input, all circuits must be inputs.

If the Block I/O Type is Output, each circuit must be an output (O).

If the Block I/O Type is Combination, each circuit can be configured as an input (I) or an output (O).

Hand-held Monitor Configuration Steps

```
I/O CIRCUIT CFG
REF
OOOOOIIIIIIIIIIII
> tgl entr nxt
```

1. Line 3 shows the I/O type of circuits 1 to 16. To select a circuit for configuration, press F1 (>).
2. To change a selection, press F2 (tgl). To save the new selection, press F3 (entr).
3. Press F4 (next) to display the I/O circuit type of circuits 17–32.
4. Press F4 (next) from the second screen I/O circuit type screen when you are ready to advance to the next configuration screen.

Report Faults to CPU

Fault reports to the host can be disabled or enabled for any circuit on a block.

If fault reporting is enabled for a circuit, the block will send a message to the host if any fault occurs on that circuit.

If Fault reporting is disabled, the block will not send fault reports to the CPU for that circuit.

Regardless of whether fault *reporting* is enabled, the block will detect faults on the circuit, and take appropriate actions. The Unit OK LED will blink when a fault occurs, and a fault report is sent to a Hand-held Monitor. The fault condition must be corrected for proper operation of the block.

If the CPU requests diagnostic information from the block using Read Diagnostics datagrams, the block returns current diagnostics for all circuits, including any with CPU fault reporting disabled.

Hand-held Monitor Configuration Steps

```
REPORT FAULTS ?  
REF  
YYYYYYNYYNNYYNN  
  tgl entr nxt
```

1. Line 3 shows the current Fault Reports selections for the first 16 circuits. On this screen,
Y = report faults.
N = do not report faults.
2. To select a circuit, press F1 (>).
3. To change a selection, press F2 (tgl). To save the new selection, press F3 (entr).
4. Press F4 (next) to display the Report Faults screen for circuits 17–32.
5. From the second Report Faults screen, press F4 (next) when you are ready to advance to the next configuration display.

Hold Last State

Each output can be independently configured to either hold its last state or to go to its powerup default state if the block loses CPU communications for at least 3 bus scans.

For a new block, Hold Last State is disabled for each output. With Hold Last State disabled, the block sets the output to its powerup default if CPU communications are lost.

If Hold Last State is enabled, the block continues to hold the output in its current state instead of setting it to the powerup default.

Outputs remain in their last state or default indefinitely or until one of the following occurs:

- Communications with the CPU are restored.
- The Hand-held Monitor changes the output by forcing it.
- Power is removed from the block.

Hand-held Monitor Configuration Steps

```
HOLD LAST STATE?  
REF  
YYYYYNNYNNXXXXXXXXXX  
> tgl entr nxt
```

1. Line 3 displays the current Hold Last State configuration of circuits 1-16. On this screen,
Y = hold last state.
N = go to default state (configured on the next HHM screen)
X = the circuit has been configured as an input.
2. To select a circuit, press F1 (>).
3. To change the selection for a circuit, press F2 (tgl).
4. To save the new selection, press F3 (entr).
5. Press F4 (next) to display the Hold Last State screen for outputs 17-32.
6. Press F4 (next) from the second Hold Last State screen when you are ready to advance to the next configuration display.

Output Default State

An output goes to its powerup default state when the block is first powered up.

If Hold Last State was NOT enabled, the block will also default the output if CPU communications are lost. On a non-redundant system, this occurs approximately 250mS after the third bus scan passes with no CPU communications. If the block is on a redundant bus downstream of a Bus Switching Module, more time is needed. (Additional default time for redundancy is explained on page 9-17).

Hand-held Monitor Configuration Steps

```
OUTPUT DEFAULT
REF
X1X1X1X0X0X0X0
> tgl entr nxt
```

1. Line 3 shows the Output Default state configuration of circuits 1–16. On this screen,
0 = the output default state is off.
1 = the output default state is on.
X = the circuit has been configured as an input.
2. To select a circuit, press F1 (>).
3. To change the selection for a circuit, press F2 (tgl).
4. To save the new selection, press F3 (entr).
5. Press F4 to display the Output Default screen for circuits 17–32.
6. From the second Output Default screen, press F4 (next) when you are ready to advance to the next configuration display.

BSM Present

If the block is connected to a single bus or to just one trunk of a dual bus, BSM Present should be set to NO.

Select YES if the block is located in a cluster connected to dual busses via a Bus Switching Module.

Hand-held Monitor Configuration Steps

```
BSM PRESENT ?  
REF  
STATUS = YES  
    tgl entr nxt
```

1. To change the configuration, press F2 (tgl).
2. To save the new selection, press F3 (entr).
3. Press F4 (next) to advance to the next configuration display.

BSM Controller

A BSM Controller is a block to which a Bus Switching Module is directly attached, which controls the BSM's switching action. Selecting a block to be a BSM Controller block has no effect on the block's I/O type – the block can still be configured as an inputs-only block, but circuit #1 cannot be physically used as an input. The first circuit will not be under CPU control.

To change this configuration with a Hand-held Monitor, the block must first be configured for BSM PRESENT. The BSM CONTROLLER menu will not appear if BSM PRESENT is set to NO.

Hand-held Monitor Configuration Steps

```
BSM CONTROLLER?  
REF  
STATUS = NO  
    tgl entr nxt
```

1. To change the configuration, press F2 (tgl).
2. To save the new selection, press F3 (entr).
3. Press F4 (next) to advance to the next configuration display.

Output Default Time

When a Bus Switching Module is used, the Output Default Time must be long enough to allow the BSM to switch without causing outputs to default. Therefore, when BSM Present is selected (above), the block automatically changes its Output Default Time from 3 bus scans to 2.5 seconds.

If Hold Last State was selected, outputs will remain in their last state, instead of defaulting, so there is no need to change this selection.

If Hold Last State was set to NO for any output on a block, and total bus scan time will exceed 100mS, change this selection to 10 seconds.

Hand-held Monitor Configuration Steps

```
OUTPUT DEF.TIME
REF
TIME = 2.5 SECS
  tgl entr nxt
```

1. To change the configuration, press F2 (tgl).
2. To save the new selection, press F3 (entr).
3. Press F4 (next) to advance to the next configuration display.

CPU Redundancy

The block can be configured for No Controller redundancy, Hot Standby or Duplex redundancy, or Genius Modular Redundancy (GMR). For new blocks, No Controller Redundancy is selected.

In Hot Standby mode, a block receives output data from two CPUs but uses the data from only one to drive its outputs. The block prefers outputs sent by the bus interface module (Bus Controller or PCIM) with Device Number 31. If those outputs are not available, the block will use outputs from the bus interface module with Device Number 30. If no outputs from either are available, the block's outputs will either Hold Last State or go to their defaults.

In Duplex redundancy mode, a block compares outputs received from two CPUs and sets any outputs for which there is disagreement to their Duplex Default state (explained next).

Select GMR mode only for blocks that will be part of a Genius Modular Redundancy system as described in the *GMR User's Manual*. Do not try to configure a block for GMR mode without referring to the detailed configuration instructions in that book.

Hand-held Monitor Configuration Steps

```
CPU REDUNDANCY
REF
NO CTRL REDUND
  tgl entr nxt
```

1. To change the current selection, press F2 (tgl).
2. Press F3 (entr) to save the new selection.
3. Press F4 (next) to advance to the next configuration display.

Duplex Default State

In Duplex Redundancy mode, if the block receives different output states for given points, the block breaks the tie by outputting the Duplex Default State to those points. For new blocks, OFF is selected for all outputs. Change it if outputs should be ON.

Hand-held Monitor Configuration Steps

```
DUPLEX DEFAULT
REF
OFF
  tgl entr nxt
```

1. To change the current selection, press F2 (tgl).
2. Press F3 (entr) to save the new selection.
3. Press F4 (next) to advance to the next configuration display.

Note

If the block loses communications with BOTH CPUs, individual outputs go to their configured Hold Last State or Output Default State.

Configuration Protection

This feature can be used to protect the block's configuration, preventing changes from the CPU or Hand-held Monitor. It can only be selected from the Hand-held Monitor. To make subsequent changes, protection must be removed again using the Hand-held Monitor. For a new block, configuration is unprotected. Before a block is used in the system, its configuration should be protected.

Hand-held Monitor Configuration Steps

```
CONFIG PROTECT
REF
DISABLED
  tgl entr nxt
```

1. To change the current selection, press F2 (tgl).
2. Press F3 (entr) to save the new selection.
3. Press F4 (next) to return to the first configuration display.