

6231BP10910

New In Stock!

ABB

<http://www.pdfsupply.com/automation/abb/623-624-series/6231BP10910>

623-624-series

1-919-535-3180

Block 115Vac/125Vdc Analog Current Source 4 Inputs / 2 Outputs
6 points

www.pdfsupply.com

Email: sales@pdfsupply.com

Chapter 11

Current-source Analog Input/Output Blocks

6231BP10910 ABB TRIO I/O

Current-source Input/Output Blocks have 4 input and 2 output circuits for 4–20mA devices.

Two Current-source Analog Blocks Input/Output Blocks are available:

- 115 VAC/125 VDC Current-source Analog 4 Input/2 Output Block (IC660BBA104)
- 24/48 VDC Current-source Analog 4 Input/2 Output Block (IC660BBA024)

Two similar blocks, described in the next chapter, provide 6 outputs for devices that accept 4 to 20mA signals. Two outputs on those blocks can also be used for 0V to 5V signals.

Features

These blocks provide isolated power to all circuits; no separate power is required for 4–20mA signals.

All circuits on the block support independent selection of linear scaling values. These values can be used to convert the internal values into engineering units suitable for the application.

A dedicated digital output is provided to drive a Bus Switching Module when a Current Source Analog block is installed in a redundant bus cable system. The 24/48 VDC Bus Switching Module (version IC660BSM021) is required for this.

Additional configurable features include:

- Input alarm detection
- Output Hold Last State or default
- Selectable input conversion time up to 400mS
- CPU Redundancy
- Output feedback checking

These blocks automatically perform the following diagnostic checks:

- Input Open Wire detection
- Input high and low alarms
- Input Overrange and Underrange
- Output Overrange and Underrange
- Output Feedback Error

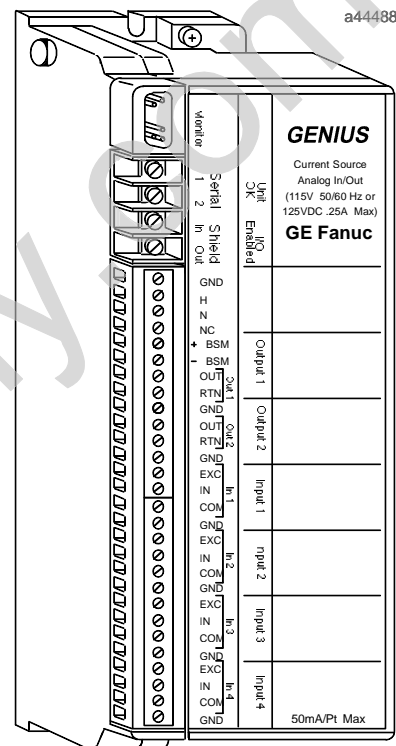

Compatibility

These blocks are compatible with all Genius bus controllers, PCIM and QBIM modules. Hand-held Monitor IC660HHM501E (version 3.7) or later is required for configuration.

For a Series Six™ PLC, the CPU must be rev. 105 or later. For a Series Six Plus PLC, rev. 110 or later is required. The programming software must be LogiMaster™ 6 rel. 4.02 or later.

For a Series Five PLC, the CPU must be rev. 3.0 or later. The LogiMaster 5 programming software must be rel. 2.01 or later.

A Bus Switching Module must be the 24/48 VDC version (IC660BSM021) only.

Specifications

Block Type: Catalog Numbers: 115 VAC/125VDC Current Source Analog block Terminal Assembly Only Electronics Assembly Only 24/48VDC Current Source Analog block Terminal Assembly Only Electronics Assembly Only	Four input/2 output circuits IC660BBA104 IC660TBA104 IC660EBA104 IC660BBA024 IC660TBA024 IC660EBA024										
Size (height x width x depth) Weight: LED's (I/O Block): Heat Dissipation: BSM Control:	8.83" (22.44cm) x 3.50" (8.89cm) x 3.94" (10.00cm) 4 lbs. (1.8 kg) Unit OK, I/O Enabled 12 Watts maximum Switches one 24/48 VDC BSM (IC660BSM021)										
Block to Block Isolation: Group to Group Isolation:	1500 V for one minute 300 V rms										
115VAC/125 VDC block power: Power supply voltage Maximum current Frequency/ripple Power supply dropout time	<table border="0"> <tr> <td>115 VAC</td> <td>125 VDC</td> </tr> <tr> <td>93–132 VAC</td> <td>105–145 VDC</td> </tr> <tr> <td>250mA</td> <td>140mA</td> </tr> <tr> <td>47–63 Hz</td> <td>10% max. ripple</td> </tr> <tr> <td>1 cycle</td> <td>10 mS min.</td> </tr> </table>	115 VAC	125 VDC	93–132 VAC	105–145 VDC	250mA	140mA	47–63 Hz	10% max. ripple	1 cycle	10 mS min.
115 VAC	125 VDC										
93–132 VAC	105–145 VDC										
250mA	140mA										
47–63 Hz	10% max. ripple										
1 cycle	10 mS min.										
24/48 VDC block power: Power supply voltage Maximum current Ripple Power supply dropout time	18–56 VDC 600mA 10% max. 10 mS min.										
Input Signal Characteristics: Input accuracy (at 25 C) Input resolution Input conversion time Range Overrange capacity Input diagnostics Channel to channel isolation Thermal drift (from 25 C)	0.1% of full scale reading 1 μ A 16.6mS to 400mS (user selectable) 4mA to 20mA 0mA to 25mA Underrange, Overrange, High Alarm, Low Alarm, Open Wire 300 volts RMS 70 PPM per degree C typical										
Input Impedance:	100 ohms \pm 5%										
Normal Mode Rejection:	–45 dB at 50, 60 Hz										
Input Excitation Characteristics: Open circuit voltage Short circuit current Loop impedance	24 VDC < 75mA 1000 ohms max. (0mA to 20mA) 800 ohms max. (20mA to 25mA)										
Output Signal Characteristics: Output accuracy at 25 C Output resolution Output update frequency Range Overrange capacity Output diagnostics: Load: Thermal drift (from 25C):	0.15% of full scale reading 6 μ A 6mS to 8mS typical 4mA to 20mA 0mA to 24mA Underrange, Overrange, Feedback error 0 ohms to 850 ohms 35 PPM per degree C typical										
Environmental: Operating Temperature Storage Temperature Humidity Vibration	0C to +60C (+32F to +140F) –40C to +100C (–40F to +212F) 5% to 95% (non-condensing) 5 – 10 Hz 0.2" (5.08mm) displacement, 10–200 Hz at 1G										

Block Operation

These blocks have four independent inputs and two independent outputs.

Input Circuits

Input channels use voltage to frequency converters and counters to translate analog currents to a digital value. This value is converted by the block to engineering units before it is sent to the CPU.

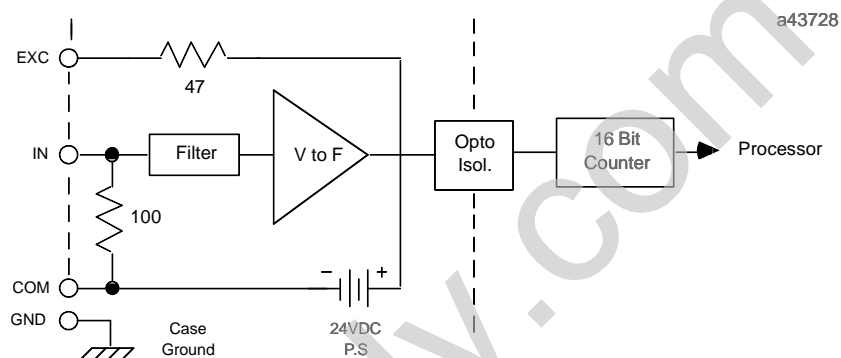

Each input has a 24 volt current loop power supply, capable of providing 25mA of current. Each input is isolated from all other circuits within the block. Input accuracy is 0.1%. Input conversion time can be selected to provide the appropriate combination of noise rejection and input resolution. Conversion times are programmable from 16mS to 400mS. Resolution increases as the conversion time is lengthened. Input resolution is 1 μ A for 200mS conversion time.

Input Data Format

Each bus scan, a Current-source Analog I/O Block broadcasts 8 bytes of input data. Each input consists of 2 bytes of scaled engineering units data. Appendix B shows reference usage for a Series 90, Series Six, or Series Five PLC.

Byte #	Description
0	Input channel 1, bits 0 – 7
1	Input channel 1, bits 8 – 15
2	Input channel 2, bits 0 – 7
3	Input channel 2, bits 8 – 15
4	Input channel 3, bits 0 – 7
5	Input channel 3, bits 8 – 15
6	Input channel 4, bits 0 – 7
7	Input channel 4, bits 8 – 15

Output Circuits

The two independent output circuits are electrically common to each other and the Bus Switching Module outputs, but isolated from all other circuits on the block. Power for the outputs' current loops is provided by the block.

Output channels use a dual 12-bit digital to analog converter, and can independently control currents from 0mA to 24mA. Output accuracy is 0.15% at 25 C. Output resolution is 6µA.

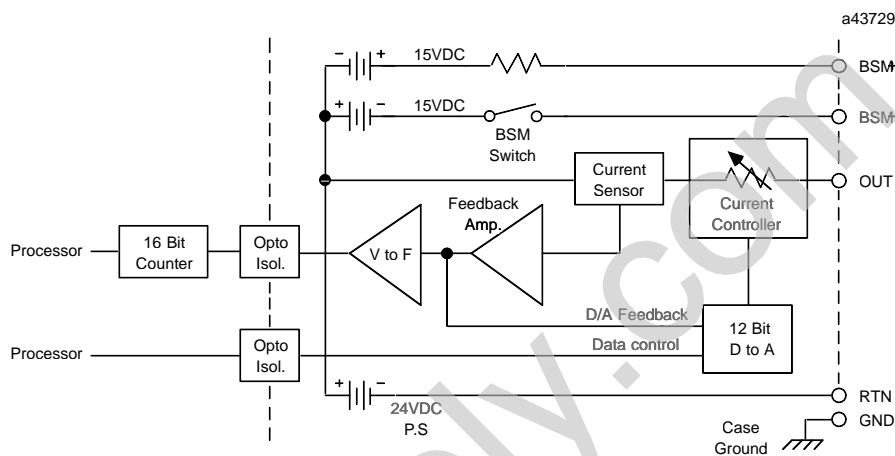

Two additional A-to-D channels are used to check the two output channels after a programmable settling time. The block will indicate a fault if the feedback from these channels does not match the commanded value to within 250µA.

Output Data Format

Each bus scan, the CPU sends a Current-source Analog I/O block 4 bytes of output data. Each analog output consists of 2 bytes of engineering units data.

Byte #	Description
0	Output channel 1, bits 0 - 7
1	Output channel 1, bits 8 - 15
2	Output channel 2, bits 0 - 7
3	Output channel 2, bits 8 - 15

The block automatically translates this engineering units value into the analog output signal used by the output device.

Hand-held Monitor I/O Display

Inputs and outputs are always reported and received as whole integers. For example, if the current value of a temperature input was 116.37E, it could be reported as:

116	degrees, or
1163	tenths of degrees, or
11637	hundredths of degrees

Here, the example input, configured as hundredths of degrees, is input 1 on the Monitor Block screen.

```
REF 97- 120I
I1: 11637
I2: 10838
>
```

PDFSupply.com

Diagnositics

Current-source Analog I/O Blocks perform the diagnostics described below. If a fault occurs, the block will report it to the Hand-held Monitor, and take appropriate corrective action.

Individual circuits can be configured not to send a diagnostic message to the CPU if a fault occurs. If the CPU requests diagnostic information from the block using a Read Diagnostic datagram, the block returns current diagnostics for all circuits, including any with CPU fault reporting disabled.

Input Open Wire Diagnostic

The block monitors input current levels. If input current is below 2mA, the block sends an Open Wire message.

Alarm Thresholds

An individual low alarm and high alarm threshold can be configured for each input. If an input reaches one of its configured limits, the block sends a High Alarm or Low Alarm message. Since the circuit's current value is also available, it is possible to determine how much beyond the limit the input is. Only one diagnostic message is sent upon reaching the limit.

Input Underrange and Overage Diagnostics

The block sends an UNDERRANGE message if current is negative, or 0mA. It sends an OVERRANGE message if the input signal exceeds 25mA.

Output Underrange and Overage Diagnostics

The block sends an UNDERRANGE message if conversion of the engineering units output it receives from the CPU results in a commanded output less than 0mA.

It sends an OVERRANGE message if conversion of the engineering units output it receives from the CPU results in an output signal level that exceeds 24mA. The block clamps the output to the selected range limit to protect external hardware.

Output Feedback Error

This diagnostic is used to detect wiring errors or other hardware faults on output circuits. After waiting for a configurable period of time, the block compares each output's current to its last commanded output value. If the difference is greater than 250 μ A, the block reports a Feedback Error. The block continues sending new values from the CPU to the output.

Nuisance diagnostics may be reported if the Output Feedback Time selected for the circuit is too brief. If this happens, increase the feedback time or disable output feedback testing.

Field Wiring

Terminals 5 through 32 are used for input power, Bus Switching Module control, and field wiring devices. These terminals accept AWG #22 to AWG #14 wires. Do not overtorque the terminal screws.

The ground (GND) terminal (5) is for block safety. It is connected to the block chassis, and to terminals 13, 16, 20, 24, 28, and 32 which are marked GND. Each channel has one ground terminal for shield termination, if desired.

Power Source Wiring

Connect an appropriate power source to terminals 6 and 7. For AC block power, connect the source to the H terminal and neutral to the N terminal. For DC block power, connect the source to the DC+ terminal and the return to the DC- terminal.

Wiring for I/O Devices

Typical wiring for various configurations is shown at right. Self-powered or externally-powered transmitters are wired differently from those powered by the block.

External Resistors for Grounded Output Loads

If both of the block's output loads are grounded, and the loads are widely separated by distance, an external resistor should be installed in each load's return line to the block. This will prevent possible damage to the block caused by the significant voltage differences that may occur between the two ground points. 10-ohm resistors are suggested.

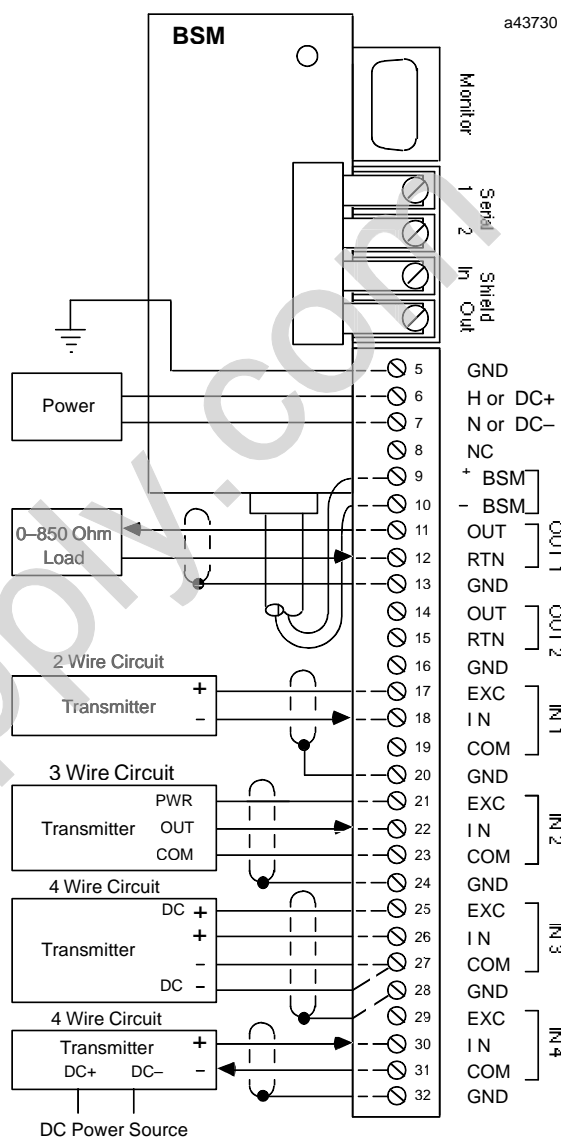

Wiring a Bus Switching Module to a CSA Block

When a Bus Switching Module is installed, connect the BSM control wires to terminals 9 and 10. The polarity from the block is as marked; the BSM is insensitive to polarity.

Block Configuration

The configurable features of a Current–source Analog 4 input/2 Output Block are listed below. For many, the factory setting may not need to be changed.

Feature	Circuit or Block	Factory Setting	Selections
Device Number*	Block	null	0 to 31 (a number must be selected)
Reference Address*	Block	none	Depends on host CPU type
Baud Rate*	Block	153.6Kbstd	153.6 st, 153.6 ext, 76.8, 38.4 Kb
Configuration Protected	Block	disabled	enabled/disabled
Report Faults	Circuit	yes	yes, no
Channel active	Circuit	active	active, inactive
BSM Present	Block	no	yes, no
BSM Controller	Block	no	yes, no
Redundancy Mode	Block	none	none, standby
Outputs timeout	Block	3 bus scans	(for bus redundancy) 2.5 or 10 sec.
Input conversion time	Block	400mS	16mS to 400mS
Input Scaling	Circuit	1 μ A/eu	" 32767 eng units 0 to +25000 μ A
Output Scaling	Circuit	1 μ A/eu	" 32767 eng units 0 to +24000 μ A
Low Alarm	Circuit	0	" 32767 eng. units
High Alarm	Circuit	+25000	" 32767 eng. units
Hold Last State	Circuit	no	yes, no
Output Default	Circuit	4000	" 32767 eng. units
Output Feedback Enabled	Circuit	yes	yes, no
Output Feedback time	Circuit	0mS	0mS to 255ms

Features marked with an asterisk in the table are configured from the Program Block ID screen of the Hand–held Monitor, as explained in chapter 3.

The rest of the features can be configured either using a Hand–held Monitor, or by sending a Write Configuration datagram to the block from the host.

Before configuration begins, the block's features should be decided on and recorded on a copy of the Configuration Worksheet printed on the next page.

Current-source Analog 4 Input/2 Output Blocks Configuration Worksheet

Block _____ Location _____

Block Features:

Configuration Protected (Y/N) _____ Block Number (0-31) _____

Reference Address _____ through _____

Baud Rate (153.6 Kb Std/153.6 Kb Ext/76.8 Kb/38.4 Kb) _____

Input Conversion Time (16mS to 400mS) _____

Redundancy Features:

Redundancy Mode (None/Standby) _____ Outputs Default (2.5/10 sec) _____

BSM Present (Y/N) _____ BSM Controller (Y/N) _____

Circuit Features:

	Input Circuits				Output Circuits	
	1	2	3	4	5	6
References: From	_____	_____	_____	_____	_____	_____
To	_____	_____	_____	_____	_____	_____
Report Faults? (Y/N)	_____	_____	_____	_____	_____	_____
Channel Active? (Y/N)	_____	_____	_____	_____	_____	_____
Scaling Points:						
Low Pt (eng units)	_____	_____	_____	_____	_____	_____
Low Pt (μ A)	_____	_____	_____	_____	_____	_____
High Pt (eng units)	_____	_____	_____	_____	_____	_____
High Pt (μ A)	_____	_____	_____	_____	_____	_____
Alarm Thresholds:						
Low (eng units)	_____	_____	_____	_____	_____	_____
High (eng units)	_____	_____	_____	_____	_____	_____
Outputs:						
Hold Last State (Y/N)					_____	_____
Default Values (eng units)					_____	_____
Output Feedback Enabled? (Y/N)					_____	_____
Output Feedback Time (0 to 255mS)					_____	_____

Report Faults to CPU

Fault reports to the host can be disabled or enabled for any circuit.

If fault reporting is enabled, the block sends a message to the host if any fault occurs.

If Fault reporting is disabled, the block does not send fault reports to the CPU for that circuit.

Regardless of whether fault *reporting* is enabled, the block detects faults on the circuit, and takes appropriate action. If a fault occurs, the block's Unit OK LED blinks and a fault report is sent to a Hand-held Monitor. The fault condition must be corrected for proper operation of the block.

If the CPU requests diagnostic information from the block using Read Diagnostics datagrams, the block returns current diagnostics for all circuits, including any with CPU fault reporting disabled.

Hand-held Monitor Configuration Steps

Line 3 shows the current Report Faults configuration of each circuit. Line 2 shows the I/O type of each circuit.

```
REPORT FAULT 97
I I I I O O
Y Y Y Y Y Y
> tgl entr nxt
```

1. To move the cursor and select a circuit for configuration, press F1 (->).
2. To change a selection, press F2 (tgl). To save the new selection, press F3 (entr).
3. Press F4 (next) when you are ready to advance to the next configuration display.

Channel Active

If a channel is not wired, or if a channel is wired but should not report diagnostics, it should be configured as an inactive channel.

The block processes input data from an inactive channel, but it does not perform fault detection on it. The Unit OK LED does not indicate faults for inactive channels.

Hand-held Monitor Configuration Steps

Line 3 shows the current Channel Active configuration of each circuit. Line 2 shows the I/O type of each circuit.

```
CH ACTIVE 97
I I I I O O
Y Y Y Y Y Y
> tgl entr nxt
```

1. To move the cursor and select a circuit for configuration, press F1 (->).
2. To change a selection, press F2 (tgl). To save the new selection, press F3 (entr).
3. Press F4 (next) to advance to the next configuration display.

Circuit Scaling

All circuits on the block can be scaled independently. To scale a circuit, two pairs of values are entered: two engineering units values and their associated signal levels. Based on these two pairs of values, the block will be able to calculate engineering units for all other input or output levels.

The block uses the scaling values to convert the input and output signal levels (0 to " 25000µA for inputs, 0 to " 24000 µA for outputs) into engineering units values. Each engineering units value is an integer to " 32767. The converted number is still a numerical value, and will appear as such on the Hand-held Monitor or at the CPU with its programming device. The applicable units of measure should be recorded separately on a meter or display.

When scaling a circuit, it is important to select units that will produce adequate resolution in the final integer value. Engineering units scaling values can be increased by a convenient multiple, such as 10 or 100, as long as the resulting engineering units values calculated by the block will not exceed the limit of " 32,767.

On a new block, circuit scaling is set to 1µA per engineering unit. If this is appropriate, it will not need to be changed. Or each input can be independently scaled. The scaling values selected should provide the maximum range for the application's engineering units.

Scaling can also be used to compensate for field device inaccuracies.

Entering Scaling Values

The most accurate scaling comes from actual measurements. The process must be set to two distinctly different conditions, so two engineering units measurements can be taken.

If the block is online to the process, it automatically provides the signal level for each engineering units measurement. If the block is not online to the process, the signal level associated with each engineering units value must also be measured external to the block.

If the process cannot be measured, you can estimate scaling values. Estimated values will not be as accurate as measured values.

If you are NOT measuring the process while scaling the circuit, have the two pairs of scaling values ready. If you ARE measuring the process to scale the circuit, set the process to one of the two conditions being measured.

Hand-held Monitor Configuration Steps

```
IN1  97- 120I
STS  ENG   A/D
    32767  4095
> scale  nxt
```

1. The next configuration screen after the Channel Active screen is this status screen. Line 1 shows which circuit is selected. If you want to scale a different circuit, press F1 (>).
2. If you are NOT measuring the process with the block online, go to step 4.

If you are measuring the process with the block online, continue at step 3.

```

IN 1 ENG  A/D
LOW  850  100
HI 30970 4000
> chng entr sts

```

3. Line 3 on the status screen shows an engineering units value and the equivalent μA signal level for the selected circuit. The engineering units value, on the left, is a calculated value. If the scaling is wrong, the engineering units value is too. The μA value, on the right, is a measured value. Make a note of the μA value; you will need it to complete the next screen.
4. Press F2 (scale) to scale the circuit.
Line 2 shows the circuit's lower pair of engineering units and μA values. All values on this screen are configured values, not measured values. Pressing F1 (>) moves the cursor.
5. Enter the engineering units value(s). This must be an integer. For greater resolution, increase the configured values by a convenient multiple, such as 10 or 100. That is, to measure tenths of degrees, you would configure low and high engineering units values of 10x the actual measured temperature. Or to measure hundredths of feet per second, you would configure engineering units values of 100x the measured velocity.
6. After each entry, press F3 (entr).
7. Enter the associated μA value(s). If you are measuring the process online, enter the value read from the HHM's status screen. If you are measuring the process with the block offline, enter the signal level obtained with an external measuring device.
8. To save the new entries for a circuit, press F3 (entr) again.
9. Press F4 (next) to return to the status screen.
10. If you are using measured values, set the process to a different condition. Repeat the necessary steps above.
11. Press F4 (nxt) to return to the status screen. From the status screen, select F1 (>) to select another circuit for scaling.
12. When you are finished scaling circuits, press F4 (nxt) to configure additional block features.

Input Conversion Time

Input conversion time determines the length of time required to make one analog to digital conversion on each input channel. The table below shows the available conversion times and their associated resolution and line rejection capabilities. For a new block, 400mS is the default. This conversion time, which provides the maximum resolution and noise rejection, is suitable for most applications.

Change it only if faster update times are required. The following table shows the available conversion times, and the resolution and noise rejection for each.

Conversion Time (mS)	Resolution		Rejected Frequencies (Hertz)
	(μ A)	(bits)	
17	12	11+	60
20	10	11+	50, 400
33	6	12+	60
40	5	12+	50, 400
67	3	13+	60
80	2.5	13+	50, 400
100	2	14	50, 60, 400
200	1	15	50, 60, 400
400	0.5	16	50, 60, 400

Hand-held Monitor Configuration Steps

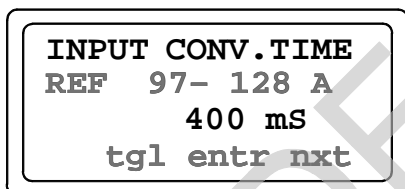

1. The screen displays the selected conversion time. If this is not appropriate, press F2 (tgl) to change it. To save the new selection, press F3 (entr).
2. Press F4 (next) to advance to the next configuration display.

Alarm Thresholds

Each input circuit can have two unique alarms, one for a low value and one for a high value. The high value should be greater than the low value. If an input reaches one of the limits, the block sends the actual value and a LOW ALARM or HIGH ALARM message. The message identifies the circuit in alarm. Only one message is sent upon reaching the threshold. Alarms do not stop the process or change the value of the input.

Alarm Thresholds are scaled values between $\pm 32,767$ engineering units. For a new Current-source Analog block, the default Alarm Thresholds are 0 (low) and +25000 (high). Typically, Alarm Thresholds are set at levels beyond which the input should not operate or levels beyond which alternate processing is required.

Because Alarm Thresholds are engineering units values, if scaling is changed, Alarm Thresholds should be reviewed and adjusted if necessary. Alarm Thresholds can also be changed by the ladder logic program in the CPU. If an input reached its high alarm, a new limit could be set. This could generate a high-high alarm or an alarm-cleared threshold. Two examples are described on page 10-18.

Hand-held Monitor Configuration Steps

ALARM	97
I1 LOW I1 HI	
-32767 32767	
> chng	nxt

1. The screen displays the low and high Alarm Thresholds for the block's first input.
2. To select the next circuit, press F1 (>) to move the cursor from LOW to HI, then press F1 (>) again.
3. To change the threshold shown at the cursor location, press F2 (chng).
4. To save the new selection, press F3 (entr).
5. Press F4 (next) when you are ready to advance to the next configuration display.

Output Feedback Testing

After the Feedback Time (see below) period has elapsed, the block compares feedback from each output to its output value received from the CPU. If these values differ by more than 250µA, the block reports a Feedback Error for the circuit. For a new block, feedback testing is enabled for each output. It can be disabled or enabled individually.

Hand-held Monitor Configuration Steps

Line 3 shows the current Output Feedback configuration of the outputs. Line 2 shows the I/O type of each circuit.

```

FEEDBACK    97
I I I I O O
X X X X Y Y
> tgl entr nxt

```

1. To move the cursor and select a circuit for configuration, press F1 (>).
2. To change a selection, press F2 (tgl).
3. To save the new selection, press F3 (entr). Press F4 (next) when you are ready to advance to the next configuration display.

Feedback Time

Feedback Time is the interval between the time the block receives an output value from the CPU, and the time the output channel is expected to attain the commanded value. This interval is used in conjunction with Feedback Testing, enabled or disabled above. A suitable interval should be selected so that the output current will reach its commanded value before the comparison is made. This prevents false Feedback Error diagnostics for the output. A longer feedback interval should be specified for outputs that respond slowly to changes in output signal levels. The Feedback Time may be in the range 0mS to 255mS. For a new block, Feedback Time of 0mS is used for each output.

Hand-held Monitor Configuration Steps

Line 3 shows the Feedback Time configured for the output circuit indicated on line 2.

```

FEEDBACK TIME
OUT1  97- 112 O
      250 mS
> chng      nxt

```

1. To select the other output, press F1 (>).
2. To change the Feedback Time for the output, press F2 (chng), then enter a new time. To save the new time, press F3 (entr).
3. Press F4 (next) when you are ready to advance to the next configuration display.

Hold Last State

Each output can be independently configured to either hold its last value or go to its powerup default value if the block loses CPU communications for at least 3 bus scans.

For a new block, Hold Last State is disabled for each output. With Hold Last State disabled, the block sets the output to its powerup default if CPU communications are lost. If Hold Last State is enabled, the block continues to hold the output at its current value instead of setting it to the powerup default.

Outputs remain in their last value or default indefinitely or until one of the following occurs:

- Communications with the CPU are restored.
- The Hand-held Monitor changes the output by forcing it.
- Power is removed from the block.

Hand-held Monitor Configuration Steps

```
HOLD LAST ST 97
I I I I O O
Y Y Y Y N N
> tgl entr nxt
```

1. The screen displays the current Hold Last State configuration of all outputs. On this screen,
 - X = the circuit is an input.
 - Y = hold last state.
 - N = go to default state (configured on the next HHM screen)
2. To select a circuit, press F1 (>).
3. To change the selection for a circuit, press F2 (tgl). To save the new selection, press F3 (entr).
4. Press F4 (next) to advance to the next configuration display.

Output Default Value

Outputs always go to their default values when the block is first powered up. For a new block, the output default value is 4000.

If Hold Last State was NOT enabled, the block will also default the output if CPU communications are lost. On a non-redundant system, this occurs approximately 250mS after the third bus scan passes with no CPU communications. If the block is on a redundant bus downstream of a Bus Switching Module, additional time is needed to accommodate switching of the BSM (see "Output Default Time" on page 11-18).

Hand-held Monitor Configuration Steps

The screen first displays the default value of the block's first output.

```
OUTPUT DEFAULT
OUT1 97- 1200
DEFAULT:    0
> chng     nxt
```

1. To select an output, press F1 (>).
2. To change a default value, press F2 (chng), then enter the new value.
3. To save the new default, press F3 (entr).
4. Press F4 (next) when you are ready to advance to the next configuration display.

BSM Present

If the block is connected to a single bus or to just one trunk of a dual bus, BSM Present should be set to NO. Select YES if the block is located in a cluster connected to dual busses via a Bus Switching Module.

Hand-held Monitor Configuration Steps

```
BSM PRESENT ?  
REF 97- 128A  
STATUS = YES  
  tgl entr nxt
```

1. To change the configuration, press F2 (tgl).
2. To save the new selection, press F3 (entr).
3. Press F4 (next) to advance to the next configuration display.

BSM Controller

A BSM Controller is a block to which a Bus Switching Module is directly attached, which controls the BSM's switching action. For a new block, the default is NO. Change it only if the block will be used as a BSM Controller.

To change this configuration with a Hand-held Monitor, the block must first be configured for BSM PRESENT. The BSM CONTROLLER menu will not appear if BSM PRESENT is set to NO.

Hand-held Monitor Configuration Steps

```
BSM CONTROLLER?  
REF 97- 128A  
STATUS = NO  
  tgl entr nxt
```

1. To change the configuration, press F2 (tgl).
2. To save the new selection, press F3 (entr).
3. Press F4 (next) to advance to the next configuration display.

Output Default Time

When a Bus Switching Module is used, the Output Default Time must be long enough to allow the BSM to switch without causing outputs to default. Therefore, when BSM Present is selected (above), the block automatically changes its Output Default Time from 3 bus scans to 2.5 seconds.

If Hold Last State was selected, the block will hold outputs at their last value while the BSM switches, instead of defaulting, so there is no need to change this selection.

If Hold Last State was set to NO for either output and total bus scan time will exceed 100mS, change this selection to 10 seconds.

Hand-held Monitor Configuration Steps

```

OUTPUT DEF.TIME
REF 97- 128A
TIME = 2.5 SECS
    tgl entr nxt
  
```

1. To change the configuration, press F2 (tgl).
2. To save the new selection, press F3 (entr).
3. Press F4 (next) to advance to the next configuration display.

CPU Redundancy

The block can be configured for No Controller redundancy or Hot Standby redundancy. For new blocks, it is set for No Controller Redundancy. It must be changed only if the block should be able to receive output data from two CPUs.

In Hot Standby mode, a block receives output data from both CPUs but uses the data from only one of them to drive its outputs. The block prefers outputs sent by the bus interface module (Bus Controller or PCIM) with Device Number 31. If those outputs are not available, the block will use outputs from the bus interface module with Device Number 30. If no outputs from a CPU are available, a Genius I/O block's outputs will either Hold Last State or go to their predefined Output Default state.

Hand-held Monitor Configuration Steps

```

CPU REDUNDANCY
REF 97- 128A
HOT STBY MODE
    tgl entr nxt
  
```

1. To change the current selection, press F2 (tgl).
2. Press F3 (entr) to save the new selection.
3. Press F4 (next) to advance to the next configuration display.

Configuration Protection

After the block is configured, its Configuration Protection should be enabled to prevent unwanted changes (from a Hand-held Monitor and from the CPU). Configuration Protection can only be set and removed by a Hand-held Monitor. For a new block, Configuration Protection is disabled.

Hand-held Monitor Configuration Steps

```
CONFIG PROTECT
REF 97- 128A
DISABLED
  tgl entr nxt
```

1. To change the current selection, press F2 (tgl).
2. Press F3 (entr) to save the new selection.
3. Press F4 (next) to return to the first configuration display.

PDFSupply.com